

DEVELOPMENT OF A CONVENTIONAL MULTIPOLE WIGGLER MPW-80

Joe Kulesza, Dave Waterman, Alex Deyhim, Eric Van Every, ADC, NY 14882, U.S.A
K. Ingvar Blomqvist, Sweden

Abstract

The design for an 80 mm period hybrid wiggler is presented. The design requirements and mechanical difficulties for holding, positioning, and driving the magnetic arrays are explored. The structural and finite element analysis, magnetic design, and electrical considerations that influenced the design are then analyzed.

This wiggler will be installed at ALBA a new synchrotron radiation source being built at the site of the Centre Direccional in Cerdanyola del Vallès, nearby Barcelona, and will produce ultra-violet and X-ray beams of exceptional brightness. The facility will comprise a 3 GeV electron storage ring, injected from a ~100 MeV linac through a full energy booster synchrotron.

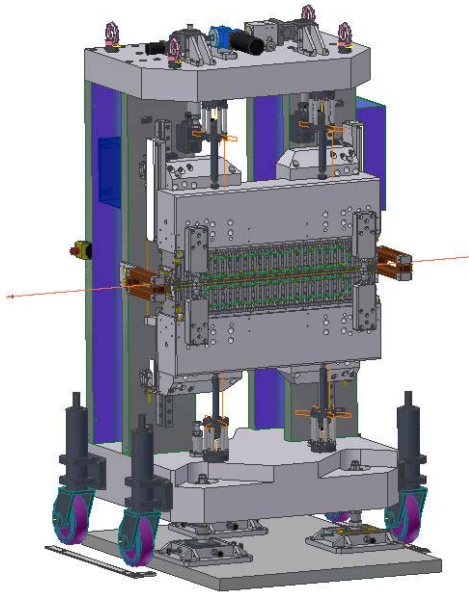

Figure 1: ALBA Multipole Wiggler

MAGNET DESIGN

The design calculations have been done using RADIA [1], a three-dimensional program for calculation of magnetic field from ESRF and SOLEIL. This program is especially developed for the design of insertion devices. The relative permeability of the permanent magnet material, 1.05 parallel to and 1.17 perpendicular to the easy axis are included in the calculations. It was decided that the width of the wiggler magnet blocks should be

reduced from 110 mm to 90 mm and the limits of the good field region from $|x| \leq 20$ mm to $|x| \leq 10$ mm to better fit the vacuum chamber. A plot of transverse roll off at the center of a full size pole at 12.5 mm gap is shown in Figure 2.

Figure 3 shows the vertical first integrals at 12.5 mm and 17.9 mm gap as functions of the transverse position. The values are within the specified range of ± 100 Gcm over the full range and can be minimized on the center line by the correction magnets. The narrower pole in the modified design give rise to integrated sextupole components in the integrals, -27 G/cm at 12.5 mm gap and 29 G/cm at 17.9 mm gap, well within the modified specification of ± 50 G/cm for the normal integrated sextupole. The skew integral is zero due to symmetry. The data can be found in Table 1.

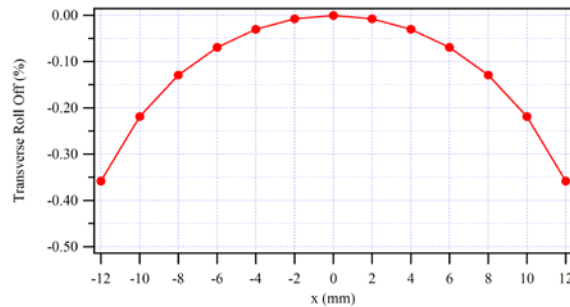

Figure 2. The transverse roll off at the center of the pole for 12.5 mm gap.

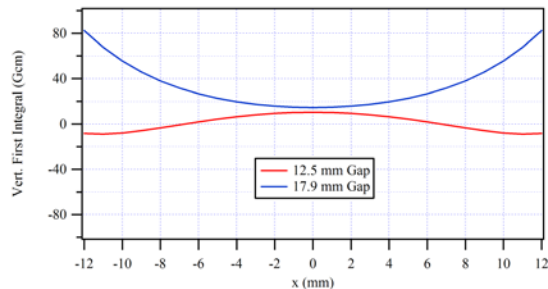

Figure 3. The vertical first integral as a function of the transverse position at 12.5 and 17.9 mm gap.

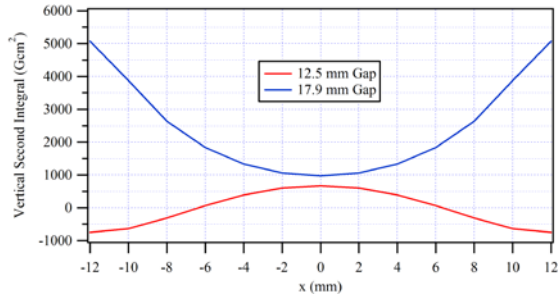

Figure 4. The second integral of the full size wiggler.

Figure 4 and Table 1 show the vertical second integrals for the full size wiggler for 12.5 and 17.9 mm gaps. The horizontal second integral is zero due to symmetry.

Figure 5 shows the integrals produced by one correction magnet with a current of 200 Ampere-turns in the short vertical coils and 450 Ampere-turns in the long horizontal coils. The current density in the coils is below 1 A/mm², a comfortable current density for air cooled coils. The field distribution on the median plane is shown in Figures 6 and 7 for 200 and 450 A-turns respectively. We expect to use 10-20% of the available strength in the correction coils.

Two correction magnets, one in front and one behind the wiggler powered by four power supplies will have a correction capability of ± 1000 Gcm for the first integrals and ± 64000 Gcm² for the second integrals. For a 3 GeV electron beam this corresponds to an angular correction of ± 100 microradians and an offset correction of ± 64 microns.

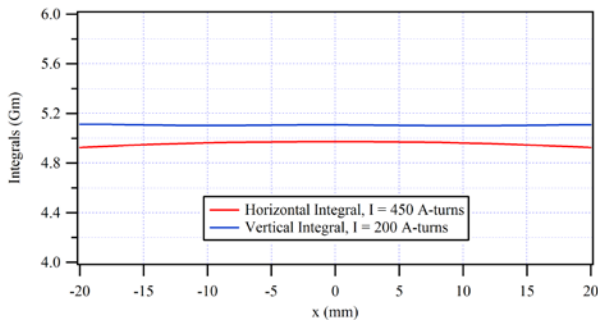

Figure 5. The first integrals produced by one correction magnet.

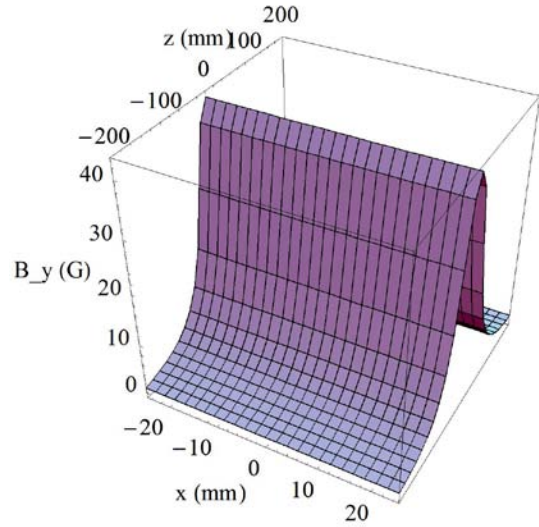

Figure 6. The vertical field on the median plane in Gauss from the correction magnet for 200 A-turns in the short coils.

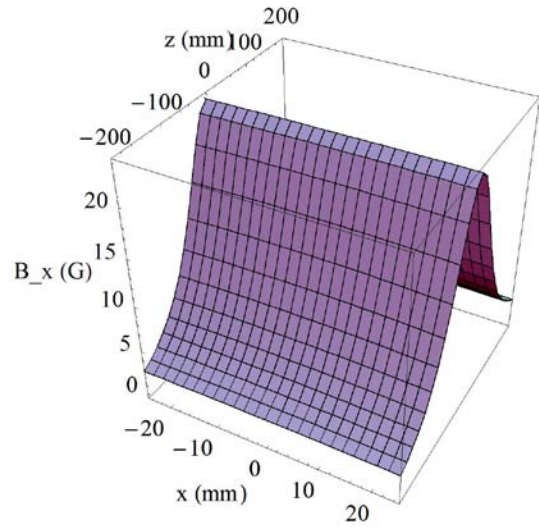

Figure 7. The horizontal field on the median plane in Gauss from the correction magnet for 450 A-turns in the long coils.

Table 1: The vertical first and second integrals for the full size wiggler at 12.5 and 17.9 mm gaps.

x (mm)	12.5 mm Gap		17.9 mm Gap	
	I _y	J _y	I _y	J _y
-12	-1000	5000	-1000	5000
-8	-500	2500	-500	2500
-4	-200	1200	-200	1200
0	500	1000	500	1000
4	200	1200	200	1200
8	500	2500	500	2500
12	1000	5000	1000	5000

	(Gcm)	(Gcm ²)	(Gcm)	(Gcm ²)
-12	-8.36	-750	82.50	5071
-10	-8.00	-634	55.51	3872
-8	-3.46	-309	37.98	2633
-6	1.82	68	26.66	1832
-4	6.33	390	19.59	1333
-2	9.35	605	15.71	1059
0	10.38	670	14.48	972
2	9.35	605	15.71	1059
4	6.33	390	19.59	1333
6	1.82	68	26.66	1832
8	-3.46	-309	37.98	2633
10	-8.00	-634	55.51	3872
12	-8.36	-750	82.50	5071

MECHANICAL DESCRIPTION

The strength of the wiggler comes from the strong back C frame. This is required to prevent the high magnetic attraction of the magnets from deforming the parallelism of the girders and to prevent any beam-line shift as the gap is changed. The strong back consists of 2 I-beams that are normally used in bridge construction. These are mounted vertically on a substantial base plate of aluminum. The I-Beams are joined at the top by a similar aluminum plate. This design is very similar to a 2 meter wiggler that was delivered and installed by ADC at the Australian Synchrotron [2].

The magnets are held in a magnet assembly with a keeper. The magnet assembly holds two main magnets, and two side magnets surrounding a pole piece. The magnets are adjusted with shims and threaded bolts. The end sections are designed to minimize the transverse offset of the electron beam in the wiggler. Magic fingers are also provided on either end for correction of the integrated multipoles.

The magnet assemblies are bolted to aluminum girders. The aluminum girders are mounted to trucks that attach to vertical bearing rail assemblies. There are 2 bearing rail guides on the top girder and 2 on the bottom.

The girders are also mounted to two left and right hand threaded ball screws. These ensure the gap motion is consistent and even during the motion. The ball nuts are preloaded and employ many circuits to ensure long life and zero backlash.

The gap ball screws are driven by a single stepper motor made by Phytron. One slip coupling is provided to protect the assembly from serious damage in the event it encounters a hard stop. The gap drive stepper motor uses

a rotary encoder to detect stepper motor slip and a brake is provided integral to the motor.

A gear box is also provided that produces a controllable taper. The gear box is mounted on a shaft between the two ball screws. A small stepper motor advances the output relative to the input but the input to output ratio is always 1:1. The stepper motor also drives a small lead screw with mechanical flags for limit switches and hard stops to prevent excessive taper. Taper can be in either direction, that is, wider at the entrance vs. exit or wider at the exit vs. the entrance. A rotary encoder is used to detect motor slip.

Gap feedback comes from two linear absolute encoders mounted across the gap at either end of the machine. These are made by TR electronics. They are programmable down to .1 um per count. They employ the Synchronous Serial Interface (SSI) used with high resolution absolute encoders.

Limit switches and hard stops are provided to limit the travel of the girders. These consist of 4 high repeatability optical switches – two on the upper and two on the lower girders - that actuate in the negative gap or vacuum chamber direction. Similarly, 4 kill switches are provided that actuate in the same direction but at a gap slightly smaller than the first set of switches. The first set of switches feedback to the ICEpap controller to prevent further motion in that direction, the second set of switches feed back to the PLC which then can disable or even power off the ICEpap controller.

ELECTRICAL DESCRIPTION

Control portion consists of the IOC PC and software, motor driver/controller (ICEpap), correction coil power supplies, and PLC code. Communication between the IOC PC and the ICEpap, PLC, and correction coil power supplies is accomplished via Ethernet.

SPECIFICATION SUMMARY

Table 2: Specification Summary

Wiggler Type	Hybrid
Wiggler Symmetry	Symmetric
Period Length	80 mm
Minimum Gap	12.5 mm
Maximum Gap	300 mm
Number of Full Size Poles	25
Total Number of Poles	27
Mag Assy/Correction Mag	1100 mm
Total Length	1375

Pole Material	Va Permendur
Permanent Magnet Material	
Minimum H_{cj}	24 kOe
Minimum Remanence B_r	1.22 T
At Minimum Gap ($B_r = 1.22$ T):	
Peak Field	1.782 T

k-value	13.32
Trans Roll Off @ $x=10$ mm	0.2%
Vertical First Integral	10 Gcm
Vertical Second Integral	680 Gcm ²
Magnetic Force	30.1 kN

REFERENCES

[1]http://www.esrf.fr/machine/groups/insertion_devices/codes/Radia/Radia.html

[2] Joe Kulesza, Eric Johnson, Dave Waterman, Alex Deyhim, 2007 Particle Accelerator Conference USA.