

Owner's Manual

QBx

15 Mini
20 Monitor
Center

Snell

SPECIFICATIONS

QBx 20 Monitor

Frequency Response ($\pm 3\text{dB}$)	65Hz–20kHz, -6dB @ 55Hz
Recommended Amplifier Power	15–150 watts (above 80Hz)
Nominal Impedance	6 ohms
Sensitivity (2.83v at 1m)	88dB SPL
Tweeter (video-shielded)	1-inch (25mm) black-anodized aluminum dome with neodymium magnet structure and multi-finned aluminum heatsink
Bass Unit (video-shielded)	6 $\frac{1}{2}$ -inch (165mm) polymer chassis, HDA cone and rubber surround
Cabinet Construction	$\frac{3}{4}$ -inch MDF walls
Composite Baffle Construction	$\frac{5}{8}$ -inch high density fiberboard, specialty adhesive, and $\frac{5}{8}$ -inch high-density fibreboard
Grille	Black cloth
Dimensions (HxWxD)	14 x 8 $\frac{1}{2}$ x 10 inches 35.6 x 21.6 x 25.5cm
Weight	38 lbs (17.24kg) / pair
Finish	Black Painted Oak, Cherry, others to special order

QBx Technology

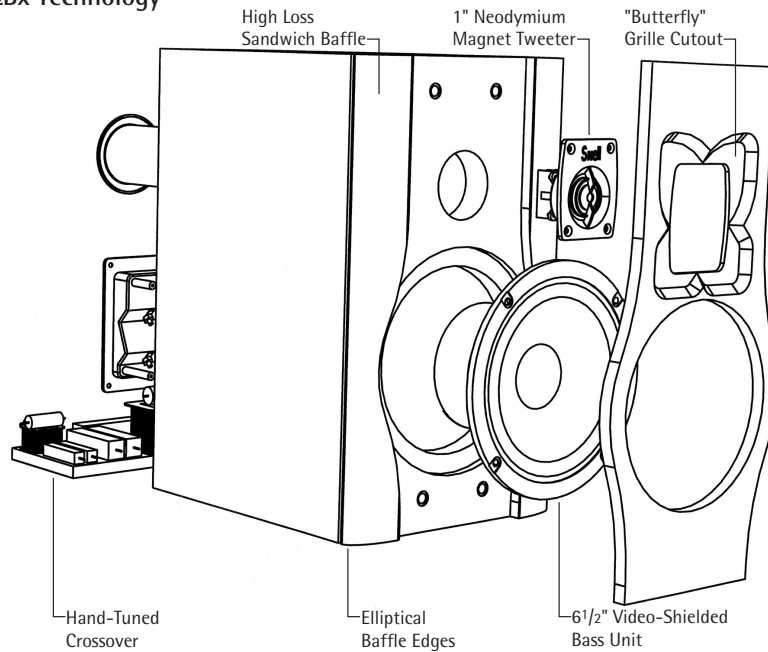

QBx Center	QBx Mini
100 Hz–20kHz, -6dB @ 90Hz	80 Hz–20kHz, -6dB @ 60Hz
15–150 watts (above 80Hz)	15–150 watts (above 80Hz)
4 ohms	6 ohms
88dB SPL	89dB SPL
1-inch (25mm) black-anodized aluminum dome with neodymium magnet structure and multi-finned aluminum heatsink	1-inch (25mm) black-anodized aluminum dome with neodymium magnet structure and multi-finned aluminum heatsink
Dual 4 inch (100mm) polymer chassis, HDA cone and rubber surround	5 ¹ / ₄ -inch (130mm) polymer chassis, HDA cone and rubber surround
³ / ₄ -inch MDF walls	³ / ₄ -inch MDF walls
⁵ / ₈ -inch high density fiberboard, specialty adhesive, and ⁵ / ₈ -inch high-density fibreboard	⁵ / ₈ -inch high density fiberboard, specialty adhesive, and ⁵ / ₈ -inch high-density fibreboard
Black cloth	Black cloth
5 ³ / ₄ x 15 ¹ / ₂ x 8 inches 14.6 x 39.4 x 20 cm	11 ³ / ₄ x 7 ¹ / ₂ x 10 inches 29.8 x 19.1 x 25.4 cm
14.5 lbs (6.58 kg) each	29 lbs (13.16 kg) / pair
Black Painted Oak, Cherry, others to special order	Black Painted Oak, Cherry, others to special order

PRODUCT DESCRIPTIONS

The QBx ("Quiet Box") 20 Monitor is a high performance monitor loudspeaker for use in a wide variety of applications. It is a two-way design that incorporates all the QBx technology features – unique cabinet construction, superior drive units, and a complex crossover. The result is exceptional with modest space requirements. The QBx 20 Monitor can be used as the main speakers of a compact music system, the front and/or rear channel speakers of a surround system, or an extension speaker in a multi-room system.

The QBx Center is tuned to match the tonal balance of the other QBx speakers – the QBx 25 Tower, the QBx 20 Monitor and the QBx 15 Mini. Seamless transitions between the QBx Center and any combination of the other QBx speakers are guaranteed. Although the QBx Center is primarily used as the center channel speaker in home theater applications, it also solidifies the center sound image when used in audio-only reproduction. It employs a 2¹/₂-way design with a 1-inch black anodized aluminum dome tweeter and two 4 inch bass units.

The QBx 15 Mini is the ideal choice for high performance sound when space is limited. When used as a rear channel speaker, or as a front channel speaker in conjunction with the QBx Sub, the QBx 15 Mini delivers tonal quality perfectly matched to the other QBx speakers. While the QBx Mini is diminutive in size, it has the full complement of QBx cabinet, driver and crossover technology.

QBx TECHNOLOGY

In an ideal speaker, the speaker cabinet is inert and resonance free. It should have smooth contours without projections that cause reflections which degrade high frequency response. In short, the cabinet should not negatively affect the sound of the loudspeaker. QBx (Quiet box) refers to a number of techniques that reduce the detrimental effects that typically come from the resonances and reflections of ordinary cabinets.

"Butterfly" grille cutout

The necessary cutout area around the tweeter is given a highly irregular contour to prevent the irregular high frequency response that would otherwise occur. The contour expands and contracts around the perimeter of the tweeter, creating a "butterfly" shape.

Elliptical baffle edges

The grille is mounted flush into the baffle. The baffle edges have large elliptical radiuses. This smooths the cabinet termination, greatly reducing the edge reflections. High frequency smoothness is preserved.

High-Loss Sandwich Baffle

The unique high-loss baffle is constructed from multiple layers of wood and a high tech adhesive. The "lossy" adhesive that laminates the two layers of speaker baffle greatly reduces cabinet resonances, resulting in purer midrange and clean, crisp bass.

Hand-Tuned Crossover

The crossover networks were designed using sophisticated computer simulation. Final system balance is determined by exhaustive listening tests. These networks adhere to an "in-phase" or Linkwitz-Reilly design: time alignment and coherency are maintained through the transition region from driver to driver. In production, each crossover is individually tuned by technicians to within ± 0.5 dB of the Master Reference, ensuring predictable performance in your home.

Drive Units

The QBx 20 Monitor and QBx 15 Mini both use a 1-inch black-anodized aluminum dome tweeter with a multifinned aluminum heatsink. The QBx 20 has a 6 $\frac{1}{2}$ -inch bass unit that has a High Definition Aerogel cone. The QBx 15 has a 5 $\frac{1}{4}$ -inch bass unit made with the same cone material.

The QBx Center uses the same tweeter as the QBx 20 Monitor and QBx 15 Mini. Bass is provided by dual 4-inch bass units that have HDA cones and rubber surrounds.

All three models feature a video-shielded driver complement, providing unlimited placement options.

HOW TO PLACE YOUR SPEAKER SYSTEMS

Front Speaker Separation

The distance between the front speakers determines the width of the stereo image. If the speakers are placed too close together, the image will be too narrow; too far apart and the blend will suffer, creating a hole in the middle. When properly placed, your speakers will create a continuum of "virtual images" from left to right, with an illusion of sound outside, in front, and behind the speaker systems.

- *We recommend an angular separation of about 50 degrees (when viewed from above). This is equivalent to a separation between the speaker systems that is about 85% of the distance from the speakers to the listener location.*

Note: When the front speakers are part of a home theater system that also has a center channel speaker, the distance between the front speakers can be somewhat greater than what is recommended here.

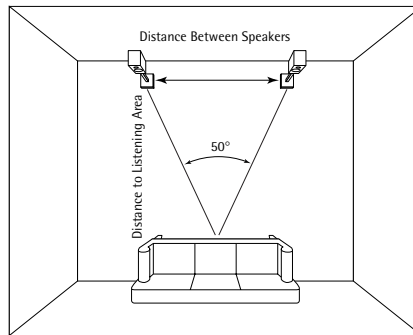

Speaker Distance

Creation of sound between the speakers requires precise placement. The front left and right speakers should both be the same distance from the listener location. We advise using a tape measure to equalize these two distances to the primary listening position. The results will be well worth the time and effort.

Aiming the Front Speakers

Your Snell speakers are designed to produce a very smooth response over as wide a range of radiated angles as possible. Like all speakers of this type, the response evenness is maintained over a wider horizontal arc than vertical (assuming the long box dimension is vertical). Take this into account when placing and aiming your speakers.

- *If the speakers are mounted very high or very low, aim the center of the speaker toward your ear level while listening in a seated position.*
- *If this is not possible, it may be preferable to place the speakers on their sides.*

Front Speaker Toe-In

"Toe-in" refers to the angling of the speaker systems toward the listener location. Toe-in is a matter of taste. As the degree of toe-in increases, the stereo effect becomes more direct-sounding, like a pair of headphones. Speakers not toed-in will give a more diffuse sound with a less defined central image.

Location Affects Bass

As speakers are moved closer to rigid room boundaries — the walls, the floor, and the ceiling — the deep bass part of the sound range is accentuated. However, if speakers are too close to the room boundaries, particularly corners, the bass output can be uneven. Experiment until you find the best overall sound for your room. Choose a musical selection with a strong, continuous bass line. Repeat a short section until you have a firm impression of it in your mind, then try another speaker location. Repeat this process until you are content with the bass response you are getting. Moving your listening position will affect the sound as much as moving the speakers. Try different listener locations as well as speaker locations.

Surround Speaker Placement

When the QBx 20 Monitor or QBx 15 Mini is used as rear channel surround speakers, they should be placed where they will produce a diffuse sound field. Your attention should not be drawn to the speakers, nor should you be able to audibly locate the speakers.

- ▶ *Mount the speakers above the listener location.*
- ▶ *The speakers should be to the sides of or behind the listener location.*

These placement recommendations minimize the chance you will be able to audibly locate the speaker. Setting the front-to-rear balance of the system is also very important. Many audio/video components have built-in signal generators that can help you set the proper balance. See the instruction manuals for your associated components for more information.

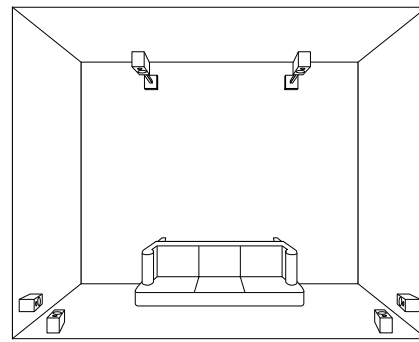

The QBx 20 Monitor Placement Switch

In some situations it may be best to position the QBx 20 Monitor in a location that does not produce the best overall sound balance. A common example is in audio/video installations where, in order to get the best sound image, the speakers must be placed next to a large cabinet or big screen television. This can cause uneven response in the upper bass and lower midrange which can make voices sound unnatural. The QBx 20 Monitor features a Placement Switch, located in the upper left corner of the terminal cup, that can help restore smooth response in such situations.

- ▶ *If the QBx Monitor is located where it has at least 12 inches (30cm) of clearance on three sides, use the Normal switch setting. If it is placed next to a large object, try the Boundary switch position to see if it results in smoother response.*

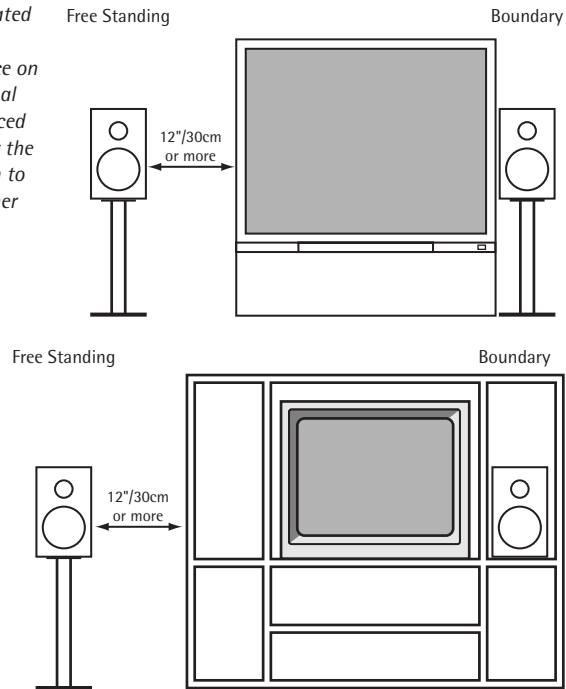

QBx Center Placement

As its name implies, the QBx Center is designed to keep dialogue or soundtrack information centered. Therefore, its placement relative to the left and right speakers is critical.

- ▶ *Place the QBx Center on top of or beneath your TV, with its front edge as far forward as practical. Try to keep the front of the speaker flush with the front of the screen.*
- ▶ *Try to place all front speakers at approximately the same height. If possible, the center speaker height should be within 2 feet (60cm) of the height of your left and right speakers.*
- ▶ *If you need to place the speaker any higher or lower, angle it toward ear level. If this is not possible, place the speaker on its side for best results.*

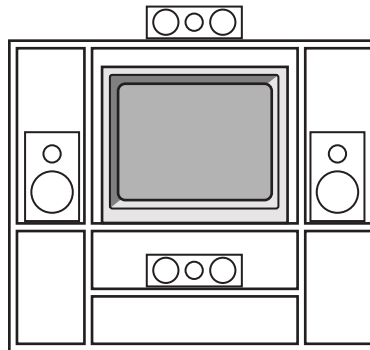

CONNECTING THE SPEAKERS

Warning! To prevent electrical shock, always switch off the amplifier or receiver when making connections to the speaker system.

Choosing cable

We recommend 16 gauge cable or thicker for runs up to 25 feet (8m) and 12 gauge wire or thicker for longer runs. (We use a custom-configured 12 gauge oxygen-free cable in our crossover networks.)

Connecting with bare wire:

- ▶ Insert bare wire into holes and tighten.

Connecting with banana plugs, pins or spade lugs:

- ▶ The gold-plated binding posts accept standard banana plugs and pins, and can accommodate spade lugs to 5/16-inch.

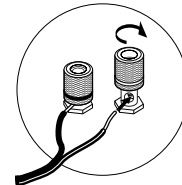

Basic Connections – QBx 20 Monitor, QBx 15 Mini and QBx Center

The QBx 20 Monitor is shown in the connection illustration. The QBx 20 Monitor has dual connection terminals that allow bi-wiring and bi-amplifying. The QBx 15 Mini and QBx Center each have a single pair of terminals, but are connected in the same way. (Ignore references to terminal jumper straps.)

- ▶ Keep the speaker terminal jumper straps on the QBx 20 Monitor in place.
- ▶ When making connections, be sure to connect + to + (red) and - to - (black).

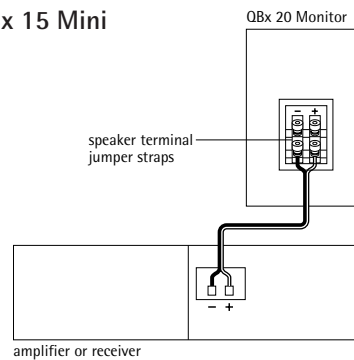

Bi-Wiring – QBx 20 Monitor only

- ▶ Use equal lengths of the same kind of cable when bi-wiring each speaker.
- ▶ Unscrew both sets of terminals and remove the jumper straps.
- ▶ When making connections, be sure to connect + to + (red) and - to - (black).

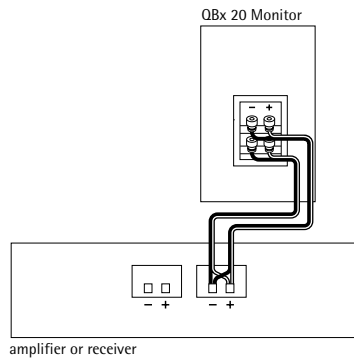

Bi-Amplifying – QBx 20

Monitor only

Using One Amplifier for the Bass and One for the High End

- ▶ Unscrew both sets of terminals and remove the jumper straps.
- ▶ Connect the cables from the bottom set of terminals to the amplifier driving the bass unit.
- ▶ Connect the cables from the top set of terminals to the amplifier driving the tweeters.
- ▶ When making connections, be sure to connect + to + (red) and - to - (black).
- ▶ Do not use an external crossover. It will interact with the phase and frequency response of the QBx.

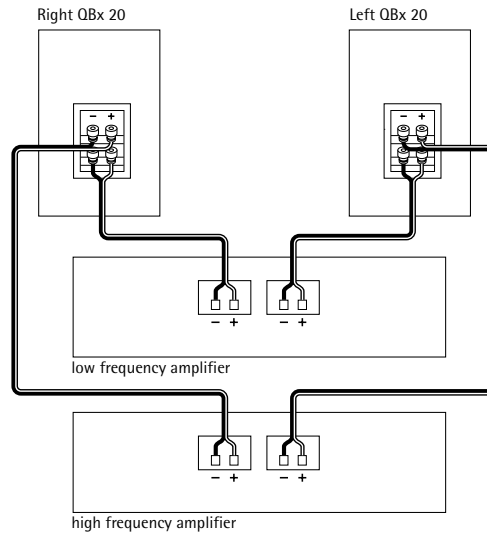

Using One Amplifier for Each Speaker

- ▶ Use two identical amplifiers.
- ▶ Unscrew both sets of terminals and remove the jumper straps.
- ▶ Connect the cables from the bottom set of terminals to the first amplifier's right channel.
- ▶ Connect the cables from the top set of terminals to the first amplifier's left channel.
- ▶ Repeat steps 2 and 3 for the second amplifier.

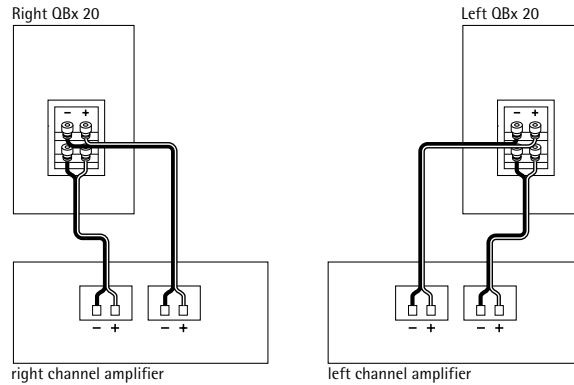

Using With a Multichannel Surround Processor

When using a subwoofer:

- ▶ *Select the SMALL setting on your receiver or processor for your main and center channels. This routes all bass information (typically below 100Hz) to your subwoofer.*

When not using a subwoofer:

- ▶ *Select the LARGE setting on your receiver or processor for your main speakers. This routes all bass information (typically below 100Hz) to your main speakers. Otherwise, bass information will be lost.*

Matching the sound levels of each speaker:

- ▶ *Your home theater system most likely includes a test signal that simplifies level matching. Refer to the instructions provided with these electronics.*

HOW TO CARE FOR YOUR SPEAKERS

- ▶ *Use a soft terry cloth towel slightly dampened with water, glass cleaner, or a diluted mild detergent. The towel should be just damp enough to wipe the surface clean without leaving a trail of moisture.*
- ▶ *Do not use abrasive cleaners or any cleaner containing chemicals harsher than those found in glass cleaner.*

LISTENING LEVELS AND POWER HANDLING

- ▶ *The power recommendation for the system assumes you will operate the amplifier in a way that will not produce distortion. All speakers can be damaged by even a modest amplifier if it is producing distortion. If you hear a gritty noise or other signs of strain, turn down the volume. Prolonged or repeated operation of your speakers with a distorted signal can cause damage that is not covered by the warranty. It is especially important that you do not overdrive the bass capability of smaller speakers. Watch for noises, such as pops, caused by the music's bass line. Use of the loudness control and/or full bass boost at louder volumes is likely to overdrive the woofer. Use such controls sparingly.*

LIMITED WARRANTY

For five years from the date of purchase, Snell Acoustics will repair for the original owner any defect in materials or workmanship that occurs in normal use of the speaker system, without charge for parts and labor.

Your responsibilities are to use the product according to the instructions supplied, to provide safe and secure transportation to an authorized Snell Acoustics service representative, and to present proof of purchase from an authorized Snell dealer in the form of your sales slip when requesting service.

Excluded from this warranty is damage that results from abuse, misuse, accidents, shipping, repairs, or modifications by anyone other than an authorized Snell Acoustics service representative. This warranty is void if the serial number has been removed or defaced.

This warranty gives you specific legal rights, and you may also have other rights that vary from state to state.

If Service Seems Necessary

Contact the dealer from whom you purchased the speaker system. If that is not possible, call us at 978-373-6114, or write to: Snell Acoustics
143 Essex Street
Haverhill, MA 01832

We will promptly advise you of what action to take. If it is necessary to return your speaker system to the factory, please ship it prepaid in the original factory packaging. Please note that Snell Acoustics will not be held liable for shipping damage due to improper packaging. After it has been repaired, we will return it freight-prepaid in the U.S. or Canada.

©2000 Snell Acoustics. All Rights Reserved.
Specifications are subject to change without notice.
Covered by patents issued and/or pending.
Part #542-1013

Snell

143 Essex Street
Haverhill, MA 01832
phone: 978-373-6114
fax: 978-373-6172
email: info@snellacoustics.com
www.snellacoustics.com