



SVI
SUN VALVE INC.

Gate Valve

Size: 2" thru 42"

Class: 150 thru 1500

Design: API600

Ends: Flanged, BW



Globe Valve

Size: 2" thru 24"

Class: 150 thru 1500

Design: API623

Ends: Flanged, BW

Check Valve

Size: 2" thru 48"

Class: 150 thru 1500

Design: API594

Ends: Flanged, BW



Cast Steel Gate, Globe & Check Valve

CAST Steel Gate Valve

Pressure Class: 150 thru 1500

Size: 2" thru 42"

Design and Manufacturing Standards
Valve Design: ASME B16.34 / API 6D API 600
Flange Dimensions: ASME B16.5/ ASME B16.47
BW End Dimensions: ASME B16.25
Face to Face Dimensions: ASME B16.10
Tested In Accordance with: API 598

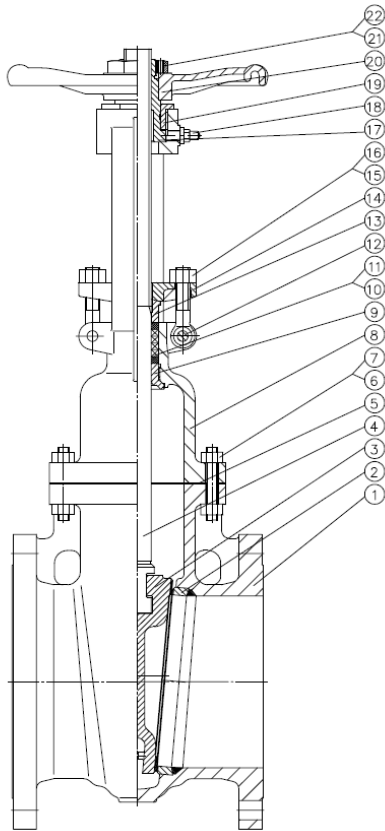

Thrust bearings for Size 12"

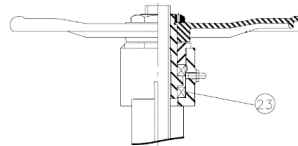

Solid wedge for Size 2"

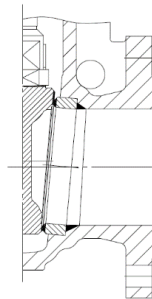

YOKE CONSTRUCTION

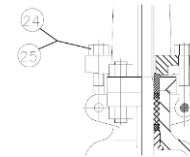

NO.	DESCRIPTION	Material list accordance to Application type				
		Standard Trim8	Low Temp Trim12	High Temp Trim5	Stainless Trim12	Sour Service
1	BODY	ASTM A216 WCB	ASTM A352 LCC	ASTM A217 WC6	ASTM A351 CF8M	ASTM A890 4A
2	SEAT RING	ASTM A105+STL	ASTM A350 LF2+STL	ASTM A182 F11+STL	ASTM A182 F316+STL	ASTM A182 F51
3	WEDGE	ASTM A216 WCB+410 Overlay	ASTM A352 LCC+316 overlay	ASTM A217 WC6+STL	ASTM A351 CF8M	ASTM A890 4A
4	STEM	ASTM A276 410	ASTM A182 F316	ASTM A182 F6a	ASTM A182 F316	ASTM A182 F51
5	GASKET	304+Graphite	304+Graphite	304+Graphite	316+Graphite	F51+Graphite
6	BONNET BOLT	ASTM A193-B7/B7M	ASTM A320-L7/L7M	ASTM A193 B16	ASTM A193 B8M CL.2	ASTM A193 B8M CL.2
7	BONNET NUT	ASTM A194 2H/2HM	ASTM A194 7/7M	ASTM A194 7/7M	ASTM A194 8M	ASTM A194 8M
8	BONNET	ASTM A216 WCB	ASTM A352 LCC	ASTM A217 WC6	ASTM A351 CF8M	ASTM A890 4A
9	BACK SEAT RING	ASTM A276 410	ASTM A1276 316	ASTM A479 410	ASTM A276 316	ASTM A182 F51
10	PACKING	Braided Graphite	Braided Graphite	Braided Graphite	Braided Graphite	Braided Graphite
11	PACKING	Flexible Graphite	Flexible Graphite	Flexible Graphite	Flexible Graphite	Flexible Graphite
12	PIN	AISI 1045	AISI 1045	AISI 1045	ASTM A276 420	ASTM A276 420
13	GLAND	ASTM A479 410	ASTM A479 410	ASTM A479 410	ASTM A276 316	UNS S31803
14	GLAND FLANGE	ASTM A216 WCB	ASTM A352 LCC	ASTM A217 WC6	ASTM A351 CF8M	ASTM A890 4A
15	EYEBOLT	ASTM A193-B7/B7M	ASTM A320-L7/L7M	ASTM A193 B16	ASTM A193 B8M CL.2	ASTM A193 B8M CL.2
16	NUT	ASTM A194 2H/2HM	ASTM A194 7/7M	ASTM A194 7/7M	ASTM A194 8M	ASTM A194 8M
17	STEM NUT	ASTM A439 D-2	ASTM A439 D-2	ASTM A439 D-2	ASTM A439 D-2	ASTM A439 D-2
18	GREASE NIPPLE	AISI 1025	AISI 1025	AISI 1025	ASTM A276 304	ASTM A276 304
19	RETAINING NUT	AISI 1025	AISI 1025	AISI 1025	ASTM A276 420	ASTM A276 420
20	HANDWHEEL	ASTM A536	ASTM A536	ASTM A536	ASTM A536	ASTM A536
21	HANDWHEEL NUT	AISI 1025	AISI 1025	AISI 1025	ASTM A276 420	ASTM A276 420
22	SCREW	AISI 1035	AISI 1035	AISI 1035	ASTM A276 304	ASTM A276 304
23	BEARING	STEEL	STEEL	STEEL	STEEL	STEEL
24	YOKE BOLT	ASTM A193-B7/B7M	ASTM A320-L7/L7M	ASTM A193 B16	ASTM A193 B8M CL.2	ASTM A193 B8M CL.2
25	YOKE NUT	ASTM A194 2H/2HM	ASTM A194 7/7M	ASTM A194 7/7M	ASTM A194 8M	ASTM A194 8M

Note: Material requested according to NACE-MR0175 as marked in red. Other material available upon request

Product Line Technical Data

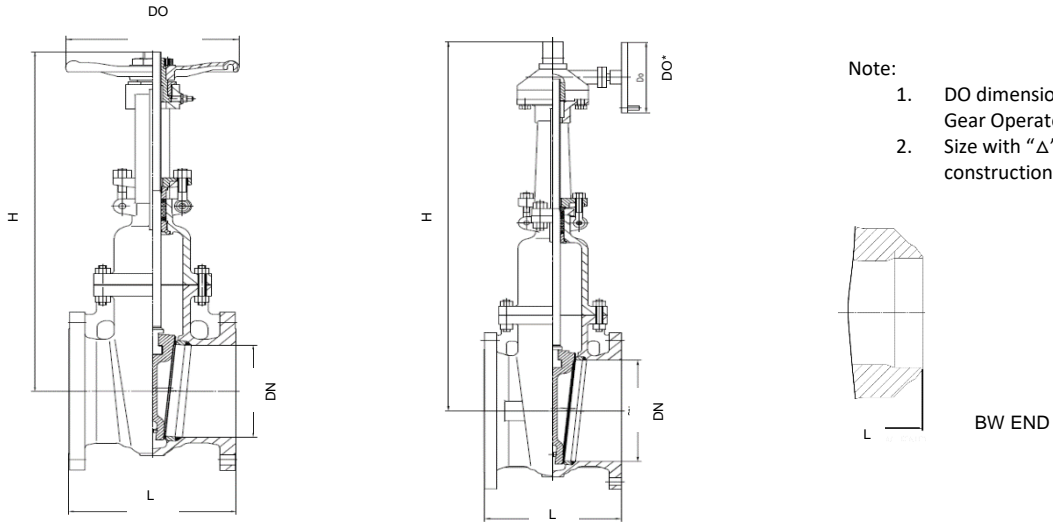

- Note:
1. DO dimension with "*" is with Gear Operator.
 2. Size with "Δ" is with Yoke construction

CLASS 150 DIMENSIONS (mm)						Weight	MF Minimum Wall Thickness
SIZE	DN	L(RF)	L(BW)	H(close)	Do	(kg)	(mm)
2"	51	178	178	313	200	14.5	8.6
3"	76	203	203	371	250	29	10.4
4"	100	229	229	438	250	42.5	11.2
6"	150	267	267	587	300	75	11.9
8"	203.2	292	292	720	350	111.5	12.7
10"	250	330.2	330.2	863	450	182	14.2
12"	300	356	356	1020	500	266.5	16.0
Δ 14"	337	381	381	1528	460*	320	16.8
Δ 16"	387	406	406	1713	460*	431	17.5
Δ 18"	438	432	432	1956	460*	620	18.4
Δ 20"	489	457	457	2131	460*	708	19.1
Δ 24"	590.6	508	508	2635	610*	1195	20.6
Δ 26"	641	559	559	2740	610*	1700	22.0
Δ 28"	692.2	610	610	3015	610*	1788	22.5
Δ 30"	743	610	610	3210	710*	1843	24.0
Δ 32"	781	660	660	3358	610*	2550	24.0
Δ 36"	876	711	711	3714	710*	2980	22.0
Δ 38"	927	737	737	4011	610*	3800	22.0
Δ 40"	978	762	762	4352	810*	4250	24.0
Δ 42"	1022	787	787	4446	810*	5400	28.6

CLASS 300 DIMENSIONS (mm)						Weight	MF Minimum Wall Thickness
SIZE	DN	L(RF)	L(BW)	H(close)	Do	(kg)	(mm)
2"	51	216	216	331	200	21	9.7
3"	76	282	282	390	250	43.5	11.9
4"	100	305	305	473	300	63	12.7
6"	152.4	403	403	605	350	109.5	16.0
8"	203.2	419	419	749	450	203	17.5
10"	254	457	457	911	500	278.5	19.1
12"	305	502	502	1044	600	403	20.6
Δ 14"	337	762	762	1576	460*	654	22.4
Δ 16"	387	838	838	1760	460*	880	23.9
Δ 18"	432	914	914	1972	460*	1108	25.4
Δ 20"	482.6	991	991	2176	610*	1695	26.9
Δ 24"	584.2	1143	1143	2632	710*	2420	30.2
Δ 26"	635	1245	1245	2865	610*	3050	31.8
Δ 28"	685.8	1346	1346	3092	610*	3893	33.3

Product Line Technical Data

△ 30"	737	1397	1397	3186	800*	4005	34.0
△ 32"	781	1524	1524	3510	1000*	5160	34.0
△ 34"	838	1626	1626	3561	800*	5600	32.0
△ 36"	876	1727	1727	3845	800*	6300	37.5
△ 40"	978	1930	1930	4414	800*	8000	38.0

CLASS 600 DIMENSIONS (mm)						Weight	MF Minimum Wall Thickness
SIZE	DN	L(RF)	L(BW)	H(close)	Do	(kg)	(mm)
2"	51	292	292	331	200	27.5	11.2
3"	76	356	356	405	300	58.5	12.7
4"	100	432	432	486	300	105	16.0
6"	152	559	559	664	500	202	19.1
8"	200	660	660	781	600	346.5	25.4
△ 10"	248	787	787	1253	460*	572	28.7
△ 12"	298.5	838	838	1490	460*	742.5	31.8
△ 14"	327	889	889	1610	460*	1016	35.1
△ 16"	375	991	991	1830	710*	1351	38.1
△ 18"	419.2	1092	1092	1991	610*	1750	41.4
△ 20"	463.6	1194	1194	2168	710*	2246	44.5
△ 24"	559	1397	1397	2567	610*	3300	50.8
△ 28"	647.7	1549	1549	2867	800*	4554	49.0
△ 30"	695	1664	1664	3382	1000*	6000	59.4
△ 32"	737	1778	1778	3711	1000*	7500	52.5
△ 36"	838	2083	2083	3840	1000*	9200	59.4
△ 40"	925	2032	2032	4270	1000*	16000	66.0

CLASS 900 DIMENSIONS (mm)						Weight	MF Minimum Wall Thickness
SIZE	DN	L(RF)	L(BW)	H(close)	Do	(kg)	(mm)
2"	51	371	371	399	300	66	19.1
3"	73	384	384	475	300	84	19.1
4"	98.5	460	460	509	350	130	21.3
6"	146	613	613	656	600	296.5	26.2
△ 8"	190.5	740	740	1050	460*	526.5	31.8
△ 10"	238	841	841	1283	610*	782	36.6
△ 12"	283	968	968	1660	610*	1320	42.5
△ 14"	311	1033	1033	1850	610*	1700	46.0
△ 16"	356	1134	1134	1874	610*	2000	52.3
△ 18"	400	1219	1219	2088	800*	2500	57.2
△ 20"	444.5	1334	1334	2417	810*	3800	63.5
△ 24"	533	1568	1568	2708	810*	5900	73.0

CLASS 1500 DIMENSIONS (mm)						Weight	MF Minimum Wall Thickness
SIZE	DN	L(RF)	L(BW)	H(close)	Do	(kg)	(mm)
2"	51	371	371	399	300	66	19.1
3"	71	473	473	475	350	124.5	23.9
4"	92	549	549	518	450	196	28.7
△ 6"	137	711	711	921	460*	446	38.1
△ 8"	178	842	842	1155	610*	842	47.8
△ 10"	222.3	1001	1001	1376	710*	1348	57.2
△ 12"	263.4	1146	1146	1557	610*	2162	66.8
△ 14"	288.8	1276.4	1276.4	1923	810*	2500	70.0
△ 16"	330.2	1406	1406	2027	810*	4000	80.0

For any Size & Pressure Not Listed, please consult with SVI sales. E-mail: Sales@sunvalveinc.com

CAST Steel Globe Valve
Pressure Class: 150 thru 1500
Size: 2" thru 24"

Design and Manufacturing Standards
Valve Design: ASME B16.34 / API 6D API 623
Flange Dimensions: ASME B16.5/ ASME B16.47
BW End Dimensions: ASME B16.25
Face to Face Dimensions: ASME B16.10
Tested In Accordance with: API 598

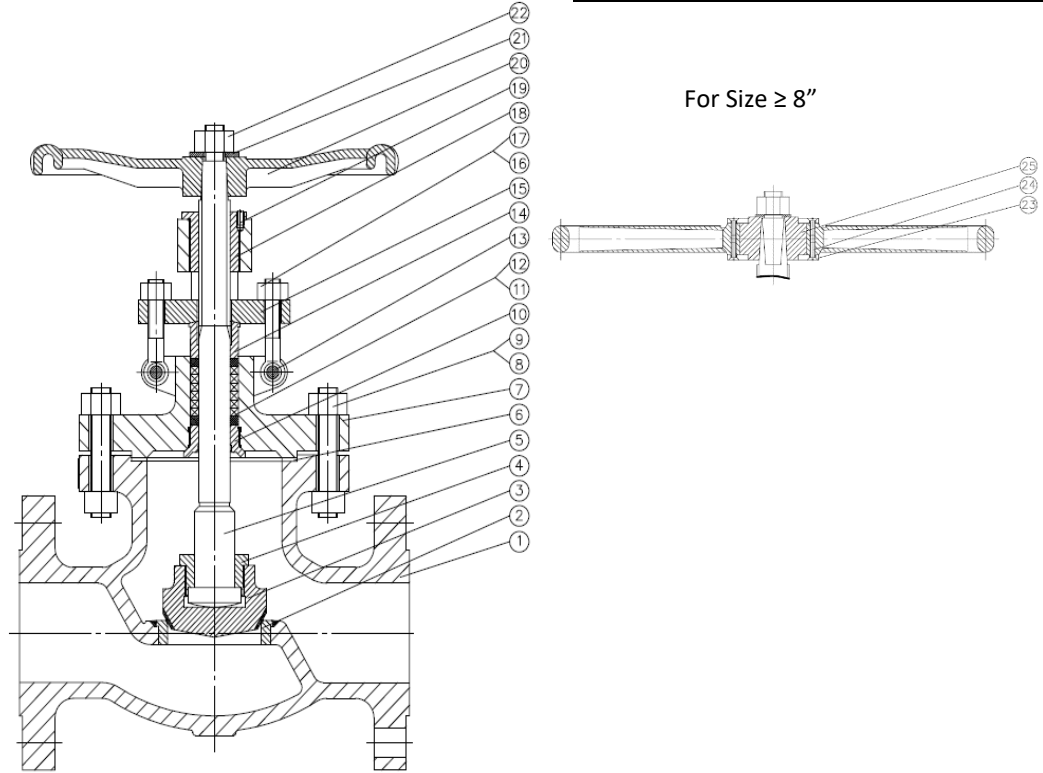

NO.	DESCRIPTION	Material list accordance to Application type				
		Standard(Trim8)	Low Temp(Trim12)	High Temp(Trim5)	Stainless	Sour Service
1	BODY	ASTM A216 WCB	ASTM A352 LCC	ASTM A217 WC6	ASTM A351 CF8M	ASTM A890 4A
2	SEAT RING	ASTM A105+STL	ASTM A182 F316+STL	ASTM A182 F11+STL	ASTM A182 F316+STL	ASTM A182 F51
3	DISC	ASTM A105+13cr overlay	ASTM A182 F316	ASTM A182 F11+STL	ASTM A182 F316	ASTM A182 F51
4	DISCE NUT	ASTM A276 420	ASTM A276 420	ASTM A276 420	ASTM A276 316	ASTM A276 316
5	STEM	ASTM A182-F6a	ASTM A479 410	ASTM A276 410	ASTM A182 F316	ASTM A182 F51
6	GASKET	304+Graphite	304+Graphite	304+Graphite	316+Graphite	F51+Graphite
7	BONNET	ASTM A216 WCB	ASTM A352 LCC	ASTM A217 WC6	ASTM A351 CF8M	ASTM A890 4A
8	BONNET BOLT	ASTM A193-B7/B7M	ASTM A320-L7/L7M	ASTM A193 B16	ASTM A193 B8M CL.2	ASTM A193 B8M CL.2
9	BONNET NUT	ASTM A194 2H/2HM	ASTM A194 7/7M	ASTM A194 7/7M	ASTM A194 8M	ASTM A194 8M
10	BACK SEAT RING	ASTM A276 410	ASTM A276 316	ASTM A479 410	ASTM A276 316	UNS S31803
11	PACKING	Braided Graphite	Braided Graphite	Braided Graphite	Braided Graphite	Braided Graphite
12	PACKING	Flexible Graphite	Flexible Graphite	Flexible Graphite	Flexible Graphite	Flexible Graphite
13	PIN	AISI 1045	AISI 1045	AISI 1045	ASTM A276 420	ASTM A276 420
14	GLAND	ASTM A276 410	ASTM A276 410	ASTM A276 410	ASTM A276 316	ASTM A276 420
15	GLAND FLANGE	ASTM A216 WCB	ASTM A352 LCC	ASTM A217 WC6	ASTM A351 CF8M	ASTM A890 4A
16	EYEBOLT	ASTM A193-B7/B7M	ASTM A320-L7/L7M	ASTM A193 B16	ASTM A193 B8M CL.2	ASTM A193 B8M CL.2
17	NUT	ASTM A194 2H/2HM	ASTM A194 7/7M	ASTM A194 7/7M	ASTM A194 8M	ASTM A194 8M
18	STEM NUT	ASTM A439 D-2	ASTM A439 D-2	ASTM A439 D-2	ASTM A439 D-2	ASTM A439 D-2
19	SCREW	AISI 1035	AISI 1035	AISI 1035	ASTM A276 304	ASTM A276 304
20	HANDWHEEL	ASTM A536	ASTM A536	ASTM A536	ASTM A536	ASTM A536
21	WASHER	AISI 1025	AISI 1025	AISI 1025	ASTM A276 420	ASTM A276 420
22	HANDWHEEL NUT	ASTM A194 2H/2HM	ASTM A194 7/7M	ASTM A194 7/7M	ASTM A194 8M	ASTM A194 8M
23	APRON PLATE	Carbon Steel	Carbon Steel	Carbon Steel	ASTM A276 420	ASTM A276 420
24	SCREW	AISI 1035	AISI 1035	AISI 1035	ASTM A276 304	ASTM A276 304
25	IMPACT PLATE	ASTM A216 WCB	ASTM A216 WCB	ASTM A216 WCB	ASTM A216 WCB	ASTM A216 WCB

Note: Material requested according to NACE-MR0175 as marked in red. Other material upon request.

Product Line Technical Data

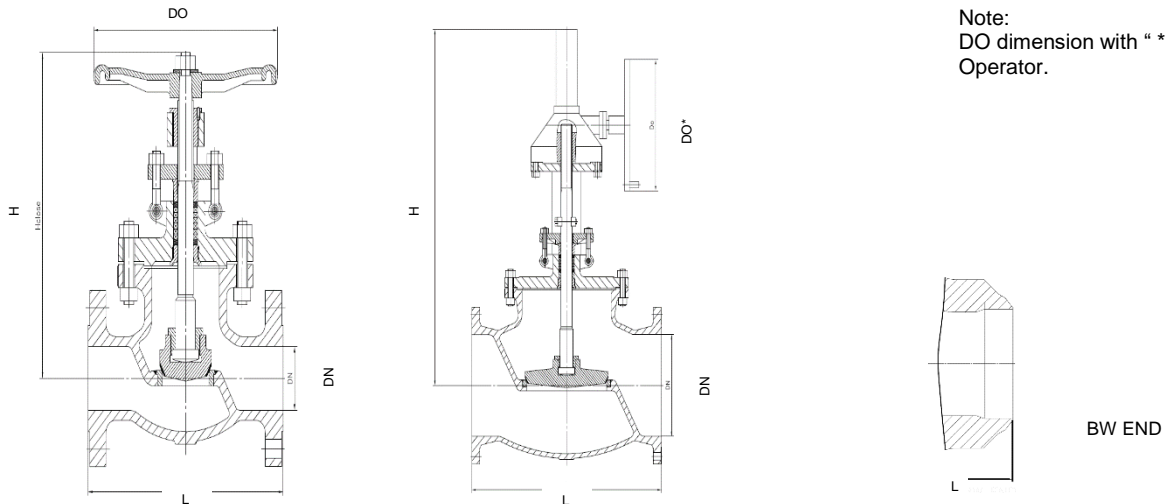

Note:
DO dimension with “ * ” is with Gear Operator.

CLASS 150 DIMENSIONS (mm)						Weight	MF Minimum Wall Thickness
SIZE	DN	L(RF)	L(BW)	H(close)	Do	(kg)	(mm)
2"	51	203	203	302	200	17	8.7
3"	76	241	241	357	300	37.5	10.4
4"	102	292	292	418	300	57	11.0
6"	152	406	406	446	400	89.5	11.9
8"	203	495	495	511	450	147.5	12.7
10"	254	622	622	581	550	196.5	13.5
12"	305	699	699	688	600	479	15.8
14"	337	787	787	1045	460*	580	16.8
16"	387	914	914	1372	610*	790	17.5
18"	438	978	978	1100	710*	850	18.3
20"	489	978	978	1177	610*	900	19.1
24"	591	1295	1295	1520	610*	1850	20.6

CLASS 300 DIMENSIONS (mm)						Weight	MF Minimum Wall Thickness
SIZE	DN	L(RF)	L(BW)	H(close)	Do	(kg)	(mm)
2"	51	267	267	302	200	22.5	9.5
3"	76	318	318	357	300	46	11.3
4"	102	356	356	423	350	75	12.7
6"	152	445	445	534	450	138	16.0
8"	203	559	559	606	550	236.5	17.5
10"	254	622	622	738	700	380.5	19.1
12"	305	711	711	827	700	617	20.6
14"	337	838	838	1245	610*	810	22.4
16"	387	914	914	1410	610*	1130	23.9
18"	432	978	978	1456	610*	1600	25.4
20"	482.6	1016	1016	1538	1000*	1720	26.9
24"	584	1346	1346	1800	1000*	2780	30.0

CLASS 600 DIMENSIONS (mm)						Weight	MF Minimum Wall Thickness
SIZE	DN	L(RF)	L(BW)	H(close)	Do	(kg)	(mm)
2"	51	292	292	345	250	34	11.1
3"	76	356	356	437	350	63.5	12.7
4"	102	432	432	513	450	118.5	15.8
6"	152.4	559	559	630	600	203	19.1

Product Line Technical Data

8"	200	660	660	739	700	446	25.4
10"	246	787	787	1135	610*	720	29.0
12"	298.5	838	838	1112	800*	1070	31.8
14"	327	889	889	1412	810*	1600	35.1
16"	375	991	991	1443	1000*	2260	38.1

CLASS 900 DIMENSIONS (mm)						Weight	MF Minimum Wall Thickness
SIZE	DN	L	L(BW)	H(close)	Do	(kg)	(mm)
2"	48	371	371	410	350	68	19.0
3"	73	384	384	498	450	131.5	19.1
4"	98	460	460	584	550	197	21.4
6"	146	613	613	819	710*	404	25.4
8"	190.5	737	737	1006	610*	722	31.8
10"	238	841	841	1329	1000*	1275	36.5
12"	282	968	968	1482	1000*	1600	42.2

CLASS 1500 DIMENSIONS (mm)						Weight	MF Minimum Wall Thickness
SIZE	DN	L(RF)	L(BW)	H(close)	Do	(kg)	(mm)
2"	48	371	371	415	400	70.5	19.0
3"	70	473	473	668	550	205	23.9
4"	98	549	549	765	550	271	28.7
6"	137	711	711	1010	610*	504	38.1
8"	178	842	842	1184	610*	1200	47.8
10"	222	1000	1000	1481	1000*	1800	57.2
12"	264	1146	1146	1533	1000*	2600	66.8

For any Size & Pressure Not Listed, please consult with SVI sales. E-mail: Sales@sunvalveinc.com

CAST Steel Check Valve
Pressure Class: 150 thru 1500
Size: 2" thru 48"

Design and Manufacturing Standards
Valve Design: ASME B16.34 / API 6D API 594
Flange Dimensions: ASME B16.5
BW End Dimensions: ASME B16.25
Face to Face Dimensions: ASME B16.10
Tested In Accordance with: API 598

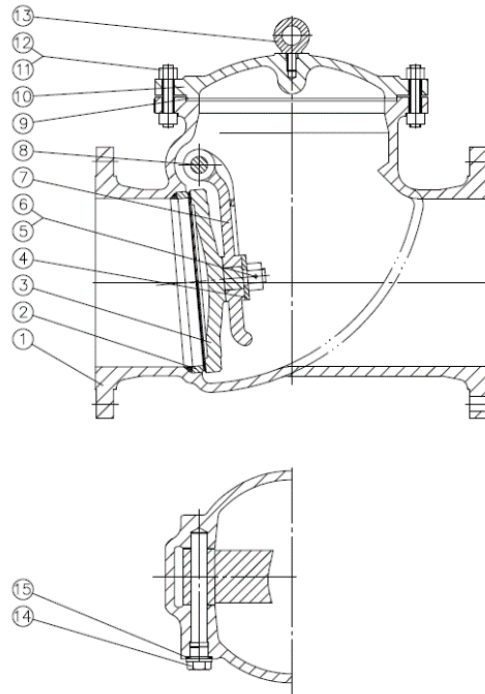

NO.	DESCRIPTION	Material list accordance to Application type				
		Standard(Trim8)	Low Temp (Trim12)	High Temp (Trim5)	Stainless	Sour Service
1	BODY	ASTM A216 WCB	ASTM A352 LCC	ASTM A217 WC6	ASTM A351 CF8M	ASTM A890 4A
2	SEAT RING	ASTM A105+STL	ASTM A350 LF2+STL	ASTM A182 F11+STL	ASTM A182 F316+STL	ASTM A182 F51
3	DISC	ASTM A216 WCB/ Cr13 Overlay	ASTM A352 LCC+316 Overlay	ASTM A217 WC6+STL	ASTM A351 CF8M	ASTM A890 4A
4	WASHER	AISI 1035	ASTM A276 316	AISI 1035	ASTM A276 316	UNS 31803
5	DISC NUT	ASTM A194 2H/ 2HM	ASTM A194 7/7M	ASTM A194 7/7M	ASTM A194 8M	ASTM A194 8M
6	DISC PIN	ASTM A276 304	ASTM A276 304	ASTM A276 304	ASTM A276 316	UNS 31803
7	HINGE	ASTM A216 WCB	ASTM A352 LCC	ASTM A217 WC6	ASTM A351 CF8M	ASTM A890 4A
8	PIN	ASTM A479 410	ASTM A479 410	ASTM A479 410	ASTM A276 316	UNS 31803
9	GASKET	304+Graphite	304+Graphite	304+Graphite	316+Graphite	F51+Graphite
10	COVER	ASTM A216 WCB	ASTM A352 LCC	ASTM A217 WC6	ASTM A351 CF8M	ASTM A890 4A
11	BOLT	ASTM A193-B7/ B7M	ASTM A320-L7/ L7M	ASTM A193 B16	ASTM A193 B8M CL.2	ASTM A193 B8M CL.2
12	NUT	ASTM A194 2H/ 2HM	ASTM A194 7/7M	ASTM A194 7/7M	ASTM A194 8M	ASTM A194 8M
13	EYEBOLT	AISI 1025	AISI 1025	AISI 1025	AISI 1025+Zn	AISI 1025+Zn
14	PLUG	ASTM A105	ASTM A350 LF2	ASTM A182 F11	ASTM A276 316	ASTM A182 F51
15	GASKET	304+Graphite	304+Graphite	304+Graphite	316+Graphite	F51+Graphite

Note: Material requested according to NACE-MR0175 as marked in red. Other material upon request

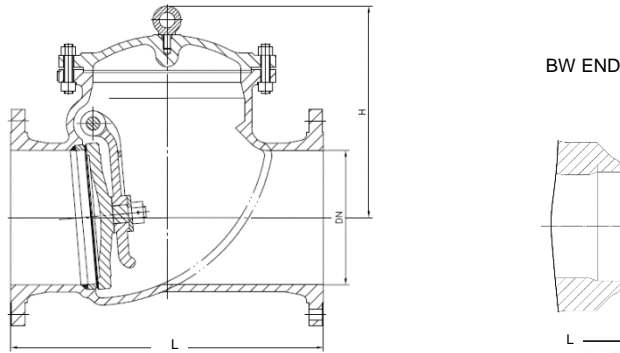

CLASS 150 DIMENSIONS (mm)					Weight	MF Minimum Wall Thickness
SIZE	DN	L(RF)	L(BW)	H	(kg)	(mm)
2"	51	203	203	131	12	8.7
3"	76	241	241	159	23	10.3
4"	102	292	292	209	38.5	11.1
6"	152	356	356	251	61	11.9
8"	203	495	495	310	103	12.7
10"	254	622	622	376	168.5	14.5
12"	305	698	698	424	257.5	16.0
14"	337	787	787	461	313.5	16.7
16"	387.4	864	864	645	602	18.0
18"	438	978	978	650	680	18.5
20"	489	978	978	655	750	19.5
24"	591	1295.4	1295.4	797	1280	20.6
28"	685.8	1447.8	1447.8	957	2050	24.0
32"	781	1524	1524	1060	2520	24.0
36"	876	1956	1956	1244	3200	26.0
42"	1020	2261	2261	1398	5000	22.0
48"	1168	2337	2337	1473	7000	24.0

CLASS 300 DIMENSIONS (mm)					Weight	MF Minimum Wall Thickness
SIZE	DN	L(RF)	L(BW)	H	(kg)	(mm)
2"	51	267	267	137	17	9.5
3"	76	318	318	169	33.5	11.9
4"	102	356	356	221	54	12.7
6"	152	444	444	275	98.5	15.9
8"	203	533	533	336	159.5	17.4
10"	254	622	622	405	242	19.1
12"	305	711	711	469	389	20.6
14"	337	838	838	608	550	22.5
16"	387.4	863.6	863.6	665	860	23.9
18"	438	978	978	710	980	25.4
20"	489	1016	1016	739	1195	26.9
24"	591	1346	1346	875	2100	30.2
26"	635	1346.2	1346.2	890	2260	29.0
28"	684	1499	1499	1011	2660	27.2
32"	779	1524	1524	1180	3900	31.0
36"	874	2083	2083	1187	5200	33.8

Product Line Technical Data

CLASS 600 DIMENSION(mm)					Weight	MF Minimum Wall Thickness
SIZE	DN	L(RF)	L(BW)	H	(kg)	(mm)
2"	51	292	292	149	22	11.10
3"	76	356	356	193	48	12.70
4"	102	432	432	256	80	15.90
6"	152	559	559	322	153	19.10
8"	200	660	660	387	294	25.40
10"	248	787	787	458	469	28.60
12"	298.5	838	838	551	650	31.50
14"	326.9	889	889	555	740	35.10
16"	375	991	991	758	1240	38.10
18"	419	1092	1092	664	1374	41.30
20"	464	1194	1194	727	1712	44.40
24"	559	1397	1397	855	2712	50.80
26"	633	1448	1448	1056	3600	50.80
30"	736.6	1651	1651	1067	5100	52.60
36"	874	2082.8	2082.8	1289	8100	59.40

CLASS 900 DIMENSION(mm)					Weight	MF Minimum Wall Thickness
SIZE	DN	L(RF)	L(BW)	H	(kg)	(mm)
2"	48	371	371	171	47	19.0
3"	73	384	384	218	64	19.0
4"	98.5	460	460	268	105.5	21.4
6"	146	613	613	334	313	26.2
8"	203.2	740	740	487	455	31.8
10"	238	841	841	616	840	36.6
12"	282	968	968	674	1180	42.5
14"	311.2	1039	1039	693	1250	46.0
16"	355.6	1140	1140	782	1900	52.3
18"	423	1232	1232	884	2620	57.2
20"	471	1334	1334	980	3950	63.5
24"	533	1568.5	1568.5	1129	5120	73.0
26"	578	1651	1651	1041	6500	63.1

CLASS 1500 DIMENSION(mm)					Weight	MF Minimum Wall Thickness
SIZE	DN	L(RF)	L(BW)	H	(kg)	(mm)
2"	48	371	371	171	47	19.0
3"	71	473	473	226	92.5	23.8
4"	92	549	549	298	156	28.6
6"	137	711	711	371	332	38.1
8"	192	842	842	606	810	47.8
10"	222	1001	1001	699	1130	50.0
12"	264	1146	1146	798	1500	66.8
14"	288.8	1276.4	1276.4	838	2410	70.0
16"	360	1408	1408	869	3320	69.0

For Size & Pressure Not Listed, please consult with SVI sales. E-mail: Sales@sunvalveinc.com

API 600 TRIM CHART & Application Guide

NOTE: This chart is provided for information only- consult current API publications to verify trim data.

API Trim Number	Material	Seat Surface	Disc Surface	Backseat	Stem	Application
1	13Cr	13Cr	13Cr	13Cr	13Cr	For oil and oil vapors and general services with heat treated seats and wedges. General very low erosive or non-corrosive service between -100°C and 320°C. This stainless steel material lends itself readily to hardening by heat treatment and is excellent for contacting parts such as stems, gates, and discs. Steam, gas & general service to 370°C. Oil & Oil vapor 480°C.
2	304	304	304	304	304	For moderate pressure in corrosive, low erosive service between -265°C and 450°C.
3	F310	310	310	310	310	For moderate pressure in corrosive or non corrosive service between -265°C and 450°C.
4	Hard Cr13	Hard 410	410	410	410	Seats 750HB min. As trim 1 but for medium pressure and more corrosive service.
5	Hardfaced	Stellite	Stellite	410	410	High pressure slightly erosive and corrosive service between -265°C and 650°C and higher pressure. Premium trim service to 650°C. Excellent for high pressure water and steam service.
5A	Hardfaced	Ni-Cr	Ni-Cr	410	410	As trim 5 where Co is not allowed.
6	13Cr and Cu-Ni	Cu-Ni	Cu-Ni	410	410	As trim 1 and more corrosive service.
7	13Cr and Hard 410	Hard 410	Hard 410	410	410	Seats 750 BHN min. As trim 1 but for higher pressure and more corrosive/erosive service.
8	13Cr and HF	Stellite	13Cr	13Cr	13Cr	Universal trim for general service requiring long service life up to 593°C. As trim 5 for moderate pressure and more corrosive service. Steam, gas & general service to 540°C. Standard trim for gate valves.
8A	13Cr AND HF	Ni-Cr	13Cr	13Cr	13Cr	As trim 5a for moderate pressure and more corrosive service
9	Monel	Monel	Monel	Monel	Monel	For corrosive service to 450°C such as acids, alkalis, salt solutions, etc. Very corrosive fluids. Erosive-corrosive service between -240°C and 480°C. Resistant to sea water, acids, alkalis. Has excellent corrosion resistance in chlorine and alkylation service.
10	316	316	316	316	316	For superior resistance to corrosion for liquids and gases which are corrosive to 410 stainless steel up to 455°C. As trim 2 but a higher level of corrosive service. Provides excellent resistance to corrosive media at high temperatures and toughness for service at low temperatures. Low temperature service standard for 316SS valves.
11	Monel and HF	Stellite	Monel	Monel	Monel	As trim 9 but for medium pressure and more corrosive service.
12	316 HF	Stellite	316	316	316	As trim 9 but for medium pressure and more corrosive service.
13	Alloy 20	Alloy 20	Alloy 20	Alloy 20	Alloy 20	As trim 10 but for medium pressure and more corrosive service.
14	Alloy 20 HF	Stellite	Alloy 20	Alloy 20	Alloy 20	As trim 10 but for medium pressure and more corrosive service.
15	304 HF	Stellite	Stellite	304	304	Very corrosive service. For moderate pressure between -45°C and 320°C.
16	316 HF	Stellite	Stellite	316	316	As trim 13 but for medium pressure and more corrosive service.
17	347 HF	Stellite	Stellite	347	347	As trim 13 but for medium pressure and more corrosive service.
18	Alloy 20 HF	Stellite	Stellite	Alloy 20	Alloy 20	As trim 2 but more erosive service & higher pressure.
NACE	Specially treated 316 or 410 trim combined optionally with B7M bolts and 2HM nuts to meet NACE MR-01-75 requirements.					
Full Stellite	Full Hardfaced trim, suitable for abrasive & severe services up to 1200°F (650°C).					

HF as "Hardfaced"

NOTE: °F=(°C*9/5)+32 °C=(°F-32)*5/9 Data reference ASME 16.34