

D Systems Residential Fire Pump
 13D Compliant Pump Submittal Data Sheet-
 1HP Dcono Package

Model F-102-D

Pump Data

- 1HP 5-3/16 Imp, 1 Stage Centrifugal Pump
- 316L SS Corrosion Resistance Construction
- Built-In Overload , Auto-Reset Provided
- 8amp 230V Single Phase UL Motor
- *110V 15amp available
- 1-1/4 F NPT Suction

Pump Flow

(not for certification use)

GPM	0	20	25	30	35	40
PSI	49	43	40	37	34	31

Components

- A - Flow Switch
- B - 1-1/4 Galvanized Riser F IPT
- C - Supervised Control Valve
- D - Pressure Gauge
- E - D Panel Control Box with Full Steel Frame
- F - 40 60 Pressure Switch
- G - Bypass Line w/ 3/4 Backflow Preventer
- H - 1 HP UL Motor w/ Pump
- *Wiring in Liquid Tight Conduit (not shown)

Check Box for Optional Equipment

- I - Butterball Tamper Switch
- J - Wired for 110 V

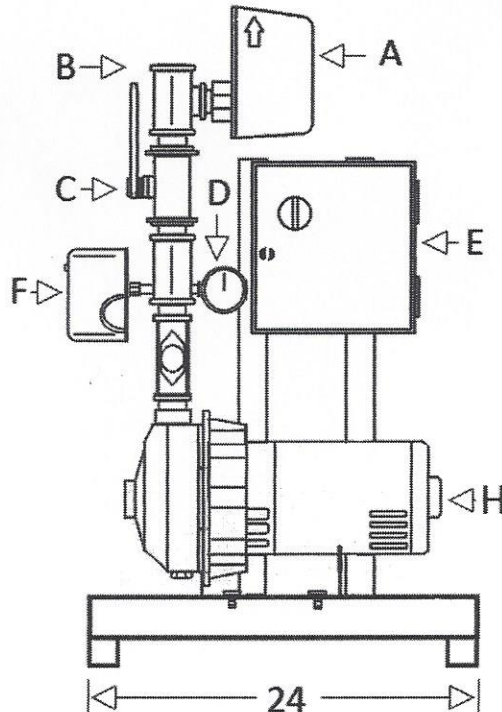
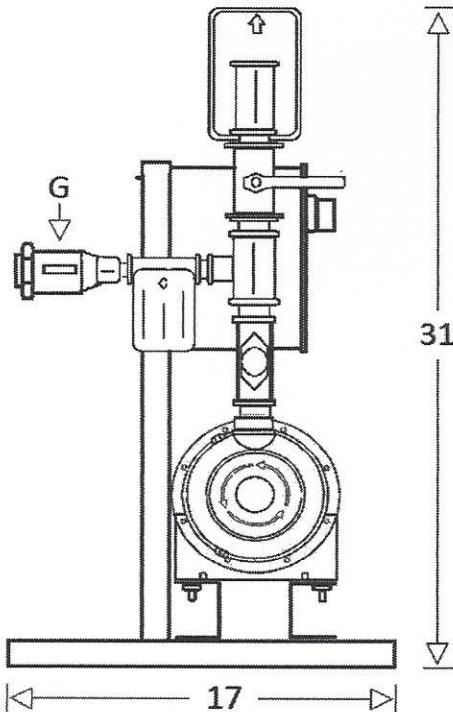

*Note: all measurement in inches