

### APPLICATION

The PVS Process Equipment LX Series Clean Bedding Delivery System is designed to pneumatically convey clean bedding material from bulk bags over a distance of up to 1,000 feet vertically and horizontally to a variety of standalone dosing style or inline bedding dispensers.

This system is a customized turnkey solution for facilities keen to take advantage of economies of scale through bulk bedding use while creating a safe working environment throughout all aspects of the operation. Through intelligent packaging, this system requires very little floor space while maintaining the large scale distribution capabilities to serve multiple areas.

### KEY FEATURES

- Turn Key Solution
- Universal Mount To ConveyORIZED Dispenser
- Redundant Bulk Bag Unloading
- Simple & Fast Installation

### OPERATION & INTERGRATION

Bulk bedding bags are loaded via pallet jack directly into the Direct from Bag Unloader in preparation for distribution. Bedding is automatically drawn from the bag and conveyed under vacuum to one or more points of distribution. Bedding can be conveyed to a wide range and mix of dispenser types across several wash facilities. Vacuum pump and controls are centrally located for ease of use and maintenance.

All system operations are monitored and controlled by a PLC based system via full color touch screens at both the unloader and dispensers. Communication between each component is designed into each system by the PVS team.

The LX series package is ideal for customers looking to take advantage of bulk bedding while improving facility operating efficiency.

Drawing data is for general reference ONLY. Certified drawings for your application available upon request.

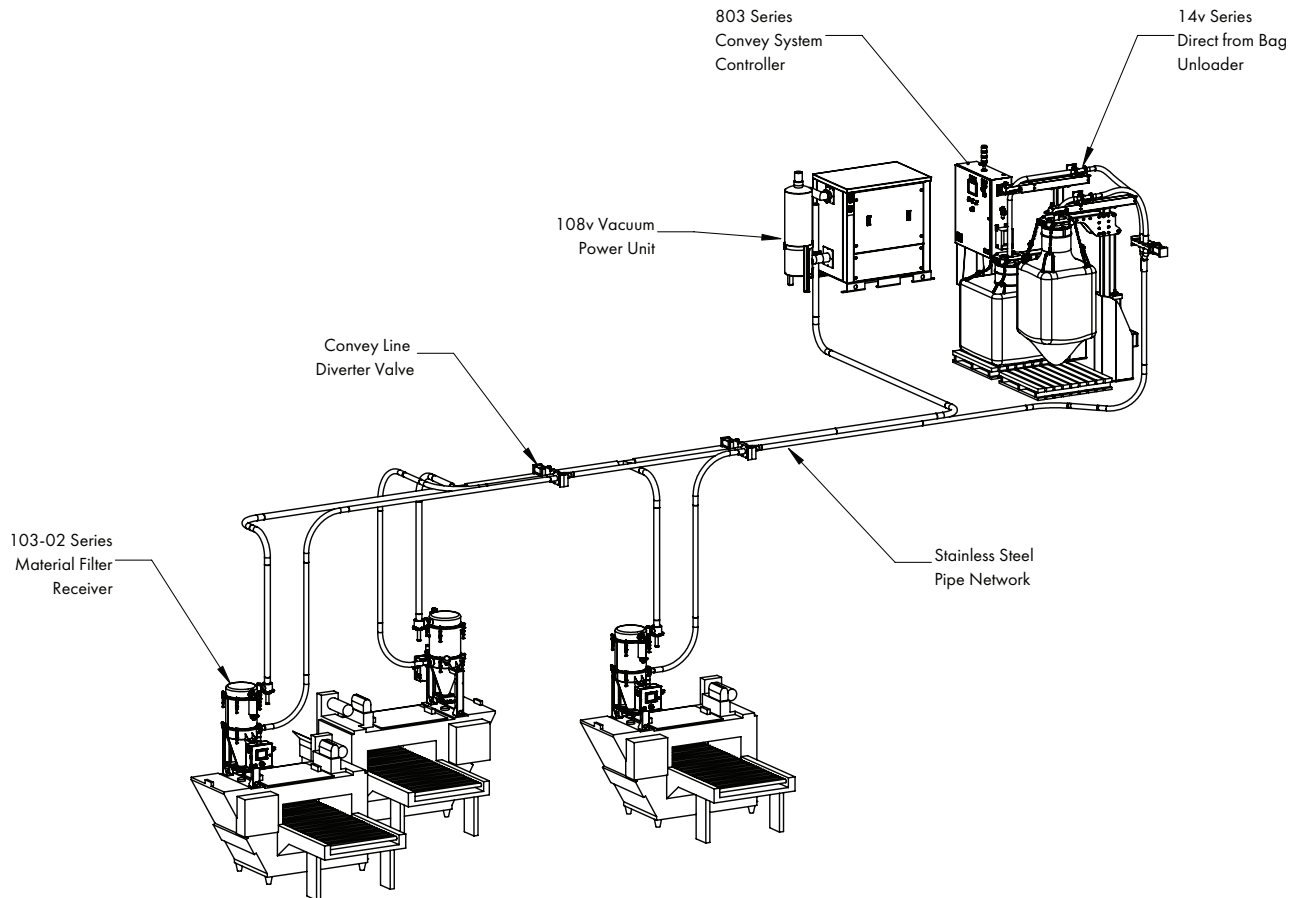

#### SYSTEM COMPONENTS:

- 14 Series Direct from Bulk Bag Unloader
- 103-02 Series Material Filter Receiver
- 504 Series Four Chute Bedding Dispenser (O)
- 803 Series Convey System Controller
- 108v Series Vacuum Power Unit
- 607 Series Cartridge Dust Collector (O)

#### UTILITY REQUIREMENTS:

##### Electrical:

- 30-60 AMP at 460 Volt, 3 Phase, 60 Hertz,
  - o 108v Vacuum Power Unit
- 5 AMP at 120 Volt, 1 Phase, 60 Hertz,
  - o 103-02 Material Filter Receiver

##### Compressed Air:

- 10 CFM at 90 PSI Clean & Dry Air (Intermittent Duty)
  - o 14v Series Direct from Bag Unloader
- 2 CFM at 90 PSI Clean & Dry Air (Intermittent Duty)
  - o 103-02 Series Material Filter Receiver

#### TECHNICAL DATA

- Stainless Steel Pipe Network
- Heavy Duty Stainless Steel Construction
- Integral Dust Control at Dispenser (504 Series Only)
- HEPA Filtered Discharge at Vacuum Power Unit
- Two (2) Color Operator Interface Screens (HMI)
- NEMA 4X S.S. & Painted NEMA 4/12 Enclosure
- PLC Fully Integrated Control Package
- Ethernet Communication Capable w/ Cellular Modem
- Compressed Air Preparation Kit
- Integral Air Compressor (O)

# CUSTOMER DRIVEN SOLUTIONS.

PVS Process Equipment | 2600 Hamburg Turnpike Suite A | Buffalo, NY 14218  
p. 716-646-0181 | f. 716-646-0157

CALL PVS TODAY  
855.244.9533