

# Operating Instruction and Parts Manual for

## KPRC160 REVERSING PLATE COMPACTOR



10601 S. SAM HOUSTON PKWY W., Suite 140  
HOUSTON, TX 77071

281-313-2506 • 800-469-4178

**WARNING:** To reduce the risk of injury, all operators and maintenance personnel must read and understand these instructions, before operating, changing accessories, or performing maintenance on our equipment. All possible situations can not be covered in these instructions. Care must be exercised by everyone using, maintaining or working near this equipment.

## INTRODUCTION

Thank you for your selection for our equipment.

We have taken care in the design, manufacture and testing of this product. It is covered by a six month warranty. Should service or spare parts be required, prompt and efficient service is available from our company or our agent.

## GENERAL SAFETY INSTRUCTION FOR THE OPERATION OF POWER EQUIPMENT

The goal of our company is to produce power equipment that helps the operator work safety and efficiently. The most important safety device for this or any tool is the operator. Care and good judgment are the best protection against injury. All possible hazards can not be covered here, but we have tried to highlight some of the important items, individuals should look for and obey caution. Warning and Danger signs placed on equipment, and displayed in the workplace. Operators should read and follow safety instructions packed with each product. Learn how each machine works. Even if you have previously used similar machines, carefully check out each machine before you use it. Get the “feel” of it and know its capabilities. Limitations, potential hazards, how it operates, and how it stops.

## APPLICATIONS

Trench compaction • Earth works • Road maintenance • Landscaping • Brickpaving • Driveway toppings

## FUNCTIONS AND CONTROLS

The motor is controlled by an ON/OFF switch or push button which is mounted on the motor below the fuel tank. Tension of the drive belt is adjustable. Loosen the four nuts on the bolts which secure the motor to the baseplate. Adjust the set screws which bear against the motor crankcase to achieve the required belt tension. Ensure that the four nuts and the set screw locknuts are tightened after adjustment.

## ACCESSORIES

Transportation Trolley-facilitates handling, Hooks into the base plate. Fitted with 200mm rubber tyres.

## HAZARDS AND RISKS

**NEVER** allow any person to operate the machine without adequate instruction.

**ENSURE** all operators read, understand and follow the operating instructions.

**SERIOUS INJURY** could result from improper or careless use of this machine.

Plates compactors are heavy units and should be positioned by two people of appropriate strength.

Using the lifting handles provided on the machine. along with correct lifting techniques.

### MECHANICAL HAZARDS!

**DO NOT** operate the machine unless all protective guards are in place.

**KEEP** handles and feet clear of rotating and moving parts as they will cause injury if contacted.

**ENSURE** that the motor operation switch is in the OFF position and the spark plug ignition lead is disconnected before removing the guards or making adjustments.

**ENSURE** both the machine and the operator are stable by setting up on level terrain and the machine will not tip over. slide off all while in operation or unattended.

**DO NOT** leave the machine in operation while it is unattended.

**ENSURE** that the walls of a trench are stable and will not collapse due to the action of the vibration, prior to commencing compaction.

**EUSURE** that the area to be compacted does not contain any “live” electrical cables, gas, water or communication services which may be damaged by the action of vibration.

**EXERCISE CARE** when operating unit. Exposure to vibration or repetitive work actions may be harmful to hands and arms.

**NEVER** stand on the unit while it is operating.

**DO NOT** increase the governed no-load motor speed above 3,500 r/min. Any increase may result in personal injury and damage to the machine.

**BE CAREFUL** not to come in contact with the muffler, when the engine is hot, since it can cause severe burns.

**ENSURE** that the repairs to the motor and machine are carried out by **COMPETENT** personnel

**FIRE & EXPLOSION HAZARDS!**

PETROL is extremely flammable and explosive under certain conditions;

ENSURE that the petrol is only stored in an approved storage container.

DO NOT refuel the motor while it is in operation or hot.

DO NOT refuel the motor in the vicinity of sparks, a naked flame or a person smoking.

DO NOT over fill the fuel tank and avoid spilling petrol when refueling .Spilled petrol or petrol vapor may ignite. If spillage occurs, ensure that the area is dry before starting the motor,

ENSURE that the fuel tank cap is securely fitted after refueling.

**CHEMICAL HAZARDS!**

DO NOT operate or refuel a petrol or diesel motor in a confined area without adequate ventilation.

CARBON MONOXIDE exhaust gases from internal combustion motor driven units can cause death in confined spaces.

**NOISE HAZARDS!**

EXCESSIVE NOISE can lead to temporary or permanent loss of hearing.

WEAR an approved hearing protection device to limit noise exposure. As required by Occupational Health and Safety regulation.

**PROTECTIVE CLOTHING**

ALWAYS wear approved hearing protection when working in a confined work space. Protective goggles and a dust mask should be worn when working in a dusty environment. Protective clothing and footwear may also be desirable when working with hot mix bitumen.

**ADDITIONAL HAZARDS!**

Slip/Trip/Fall is a major cause of serious injury or death. Be aware of uneven or slippery work surfaces.

Exercise care when working in the vicinity of unprotected holes or exca

**OPERATION****Pre start-up inspection**

The following Pre-start-up inspection must be performed before the start of each work session or after every four hours of use. Which ever is first. If any fault is discovered, the compactor must not be used until the fault is rectified.

1. Thoroughly inspect the compactor for signs of damage. Check components are present and secure. Pay special attention to the belt drive safety guard fitted between the engine and the vibrator unit.
2. Check the engine oil level and top up as necessary
3. Check the engine fuel level and top up as necessary
4. Check for fuel and oil leaks

**Start and stop Procedure for Petrol Engine**

1. Open the fuel tap by moving the fuel ON/OFF lever fully to the right.
2. If starting the engine from cold, set the choke ON by moving the choke lever fully to the left. If restarting a warm engine, he choke is usually not required. However, if the engine has cooled to a degree, partial choke may be required.
3. Turn the engine ON/OFF switch clockwise to the "1" position.
4. Set the throttle to the idle position by moving the throttle lever fully to the right. Do not start the engine on full throttle, As the compactor will vibrate as soon as the engine starts.
5. Taking a firm hold o the control handle with one hand, grasp the recoil starter handle with the other., pull the recoil starter until engine resistance is felt. Then let starter return.
6. Taking care not to pull starter's cope fully out. pull the starter handle briskly.
7. Repeat until the engine fires.
8. Once the engine fires gradually, set the choke lever to the OFF position by moving It to the right.
9. If the engine fails to fire after several attempts, follow the trouble-shooting guide on page 5.
- 10 .To stop the engine, set the throttle to idle and turn the engine ON/OFF switch anticlockwise o the "0" position.
11. Turn the fuel off

The machine is best suited to the compaction of bituminous and granular materials e.g. granular soils such as silt and clay are best compacted using the impact force produced by a vibrating rammer.

Where possible the site should be graded and leveled before commencing compaction.

For more information of starting and correct operating procedures of the motor, refer to the motor operation manual supplied with the unit.

Increase the motor speed to the maximum setting using the hand throttle lever, before commencing compacting.

The machine should be controlled by grasping the handle with supplied with the unit.

Increase the motor speed to the maximum setting using the hand throttle lever, before commencing compacting.

The machine should be controlled by grasping the handle with both hands and applying restraint to control the forward motion.

Steer the machine by moving the handle sideways to the right or left;

ALWAYS maintain good footing so that you do not slip and lose control when starting or operating the machine;

Inspect the water hose and its connections to ensure that they do not leak.

## CARE AND PREVENTIVE MAINTENANCE

Check the oil level in the motor crankcase daily.

Check the vibrator oil level weekly.

Inspect the rubber anti vibration mounts for wear or deterioration. Inspect the water hose and its connections to ensure that they do not leak. Clean the underside of the plate regularly to prevent a build up of material.

Use unleaded grade petrol and ensure that the fuel is free from contamination.

The vibratory motion provides a self propelling action.

Position the handle at the opposite end of the machine to the vibrator.

Start the motor using the recoil starter.(If the motor is fitted with an on/off switch this must first be turned to ON before starting.)

Correct moisture content in soil is vital to proper compaction.

Water acts as a lubricant to help slide soil particles together.

Too little moisture means inadequate compaction; too much moisture leaves water-filled voids that weaken the soil's load bearing ability.

Compaction of dry materials will be facilitated by moistening with a water hose fitted with a sprinkler.

Excessive watering or water content will cause the machine to stall.

The optional water tank kit is recommended when the machine is used on bituminous surfaces as the water film prevents

A build up of material on the underside of the plate.

## CAUTION



Inspection and other services should always be carried out on hard and level ground with the engine shut down.

Inspection and maintenance Service Tables

To make sure your plate compactor is always in good working condition before using, carry out the maintenance inspection in accordance with Tables 1 through 3.

**TABLE 1. MACHINE INSPECTION**

ITEM	Hours of Operation
(Starting Check)	Every 8 hours ( every day)
Loosened or lost screws	Every 8 hours ( every day)
Damage of any part	Every 8 hours ( every day)
Function of controlling system part	Every 8 hours ( every day)
Vibrator oil check	Every 100 hours
Vibrator oil replacement	Every 100 hours
V-belt (Clutch)	Check Every 100 hours

**TABLE 2.ENGINE CHECK****( For details, see separate engine manual)**

<b>ITEM</b>	<b>Hours of Operation</b>
Leakage of oil fuel	Every 8 hours ( every day)
Tightness of fastening Threads	Every 8 hours ( every day)
Engine oil check and replenishment	Every 8 hours ( every day) (Replenish to specified Max. Level)
Engine oil replenishment	At first 20 hours, then every 100 hours
Air cleaner cleaning	Every 50 hours

**CAUTION** 

These inspection intervals are for operation under normal conditions. Adjust your inspection intervals based on the number hours plate compactor is in use, and particular working conditions.

**CAUTION** 

Fuel piping and connections should be replaced every 2 years.

**Daily Service**

Check for leakage of fuel or oil.

Remove soil and clean the bottom of compaction plate.

Check for loose screws including tightness. See Table 3 below ( Tightening torque), for retightening.

**TABLE 3****TIGHTENING TORQUE (in.kg/cm) Diameter**

Material	6mm	8mm	10mm	12mm	14mm	16mm
4T	70	150	300	500	750	1100
6-8T	100	250	500	800	1300	2000
11T	150	400	800	1200	2000	2900

**Changing Vibrator Oil**

When changing the vibrator oil, remove the drain plug located at the bottom-right of the vibrator, and simply tip the compactor to drain the oil. Note that the oil will drain more easily while it is hot. Replace the oil with 200ML of 10W-30 motor oil.

**Air Filter**

1. The air filter element should be cleaned because a clogged air cleaner can cause poor engine starting, lack of power and shorten engine life substantially.
2. To clean or replace air filter loosen the wing nut on the air filter housing (Figure 1), remove the cover and take out air filter cartridge. If only cleaning of the air filter is desired blow through the air filter cartridge from the inside, moving a jet of dry compressed air up and down until all dust is removed.

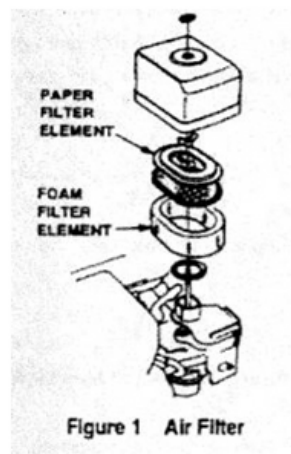

**CAUTION:** 

NEVER attempt to check the V-belt with the engine running. Severe injury can occur if your hand gets caught between the V-belt and the clutch. Always use safety gloves.

**Checking and Replacing the V-belt and Clutch**

After 200 hours of operation, remove the upper belt cover to check the V-belt tension (Figure 2). Tension is proper if the belt bends about 10mm when depressed strongly with finger between shafts. Loose or worn V-belts reduce power transmission efficiency, cause weak compaction and reduces the life of the belt itself.

**CAUTION:** 

Whenever the compactor's vibration becomes weak or lost during normal operation regardless of operation hours, check the V-belt and clutch immediately.

**Replacing the V-belt**

Remove the upper and lower belt covers, Engage an offset wrench (13mm) or the like to vibrator pulley (Lower) fastening bolt. Engage waste cloth or the like at mid-way of V-belt on the left side and while pulling it back strongly, rotate the offset wrench clockwise so that the V-belt will come off.

**Reinstalling the V-belt**

Engage V-belt to the lower vibrator pulley and push the V-belt to the left side of upper clutch and, in the same manner as in removal, rotate offset wrench clockwise so that the V-belt goes back on.

**Checking Clutch**

Check the clutch simultaneously with V-belt checking. With belt removed, check outer drum of the clutch for seizure and "V" groove for wear or damage with your eyes. Clean the "V" groove as necessary. Wear of lining or shoe should be checked with running check. If the shoe is worn, power transmission becomes deficient and slipping will result.

**KPC160 PLATE COMPACTOR**

Model	KPC160H	KPRC160R	KPC60L	KPRC160K
Engine	Air-cooled, single cylinder, 4-stroke			
Engine Type	Petrol, Honda GX160	Petrol, Robin EY20	Petrol, Loncin G270F	Diesel Kipor 170F
Power (hp)	5.5(4.0kw)	5.7(4.2kw)	5.0(4.0kw)	3.8(2.8kw)
Weight (kg)	125(275 lbs)	125(275 lbs)	125(275 lbs)	130(286 lbs)
Centrifugal force	25			
Frequency (vpm)	4300(72Hz)			
Compaction depth (cm)	30(12in)			
Travel speed (cm/s)	28(11in/s)			
Efficiency (m <sup>2</sup> /hr)	400(4300 ft <sup>2</sup> /hr)			
Plate Size (cm)	62×40(24×16in)			
Dimension (cm)	120×40×93(47×16×37in)			

**Drive Belt:** 1×"B" section vee belt

**Acoustic Noise** ( According to 2000/14/EC)

Model No.	KPC160W
Measured Sound Power Level	101.5dB
Guaranteed sound power level	104.50dB
Uncertainly	3dB

**Hand-Arm-Vibration** ( as per ISO8662, part 1, m/s<sup>2</sup>):4-9

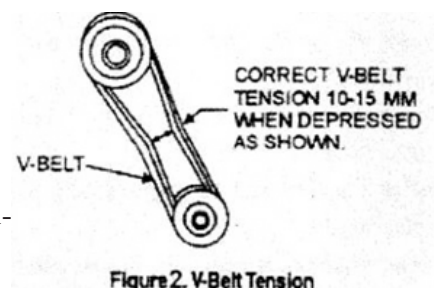

Figure 2. V-Belt Tension

## TRANSPORTATION

1. Always shut off engine when transporting machine.
2. Make sure lifting device has enough capacity to hold machine ( see identification plate on machine for weight).
3. Use central lifting point (a) (c) (as optional) when lifting machine.
4. Trolley wheel (b) as optional is used for short distance transportation.

TROUBLE SHOOTING		
SYMPTOM	POSSIBLE CAUSES	SOLUTION
Travel Speed too low, and vibration is weak	Engine speed too low?	Set engine speed to correct RPM.
	Clutch slips?	Check or replace clutch
	V- belt slips?	Adjust or replace V-belt
	Excessive oil in vibration?	Drain excess oil and fill to proper level
	Malfunction in vibrator housing?	Check eccentric, gears and counter weights
	Bearing Failure?	Replace Bearing
	Insufficient engine output?	Check engine, compression, etc.

## ENGINE TROUBLE SHOOTING

SYMPTOM	POSSIBLE CAUSES	SOLUTION
Difficult to start, "Fuel is available, but no SPARK at spark plug".	Spark plugs bridging?	Check gap, insulation or replace spark plug.
	Carbon deposit on spark plug?	Clean or replace spark plug.
	Short circuit due to deficient spark plug insulation?	Check spark plug insulation, replace if worn
	Improper spark plug gap?	Set to proper gap
Difficult to start, "Fuel is available, but no SPARK at spark plug".	ON/OFF switch is shorted?	Check switch wiring, replace switch
	Ignition coil defective?	Replace ignition coil
	Improper spark gap, point's dirty?	Set correct spark gap and clean points
	Condenser insulation worm of short circuiting?	Replace condenser
Difficult to start, "Fuel is available, spark is present and compression is normal".	Spark plug wire broken or short circuiting?	Replace defective spark plug wiring
	Wrong fuel type?	Flush fuel system, and replace with correct type of fuel
	Water or dust in fuel system?	Flush fuel system
Difficult to start, "Fuel is available, spark is present and compression is low".	Air cleaner dirty?	Clean or replace air cleaner
	Suction/exhaust valve stuck or protruded?	Re-seat valves
No fuel present at arburetor	Piston ring and/or cylinder worn?	Replace piston rings and or piston
	Cylinder head and/or spark plug not tightened properly?	Torque cylinder head bolts and spark plug
	Fuel not available in fuel tank?	Fill with correct type of fuel
"Weak in power" compression is proper and does not mistires	Fuel cock does not open properly?	Apply lubricant to loosen fuel cock level, replace if
	Fuel filter clogged?	Replace fuel filter
	Fuel tank cap breather hole clogged?	Clean or replace fuel tank cap
	Air in fuel line?	Bleed fuel line
	Air cleaner not clean?	Clean or replace cleaner
"Weak in power" compression is proper but mistires	Improper level in carburetor?	Check float adjustment, re-build carburetor
	Defective spark plug?	Clean or replace spark plug
	Water in fuel system?	Flush fuel system, and replace with correct type of fuel
Engine overheats	Dirty spark plug?	Clean or replace spark plug
	Ignition coil defective?	Replace ignition coil
	Spark plug heat value improper?	Replace with correct type of spark plug
Rotational speed fluctuates.	Correct type of fuel?	Replace with correct of fuel
	Cooling fins dirty?	Clean cooling fins
	Governor adjusted correctly?	Adjust governor
Recoil starter malfunction	Governor spring defective?	Replace governor spring
	Fuel flow restricted?	Check entire fuel system for leaks or clogs
	Recoil mechanism clogged with dust and dirt?	Clean recoil assembly with soap and water
	Spiral spring loose?	Replace spiral spring

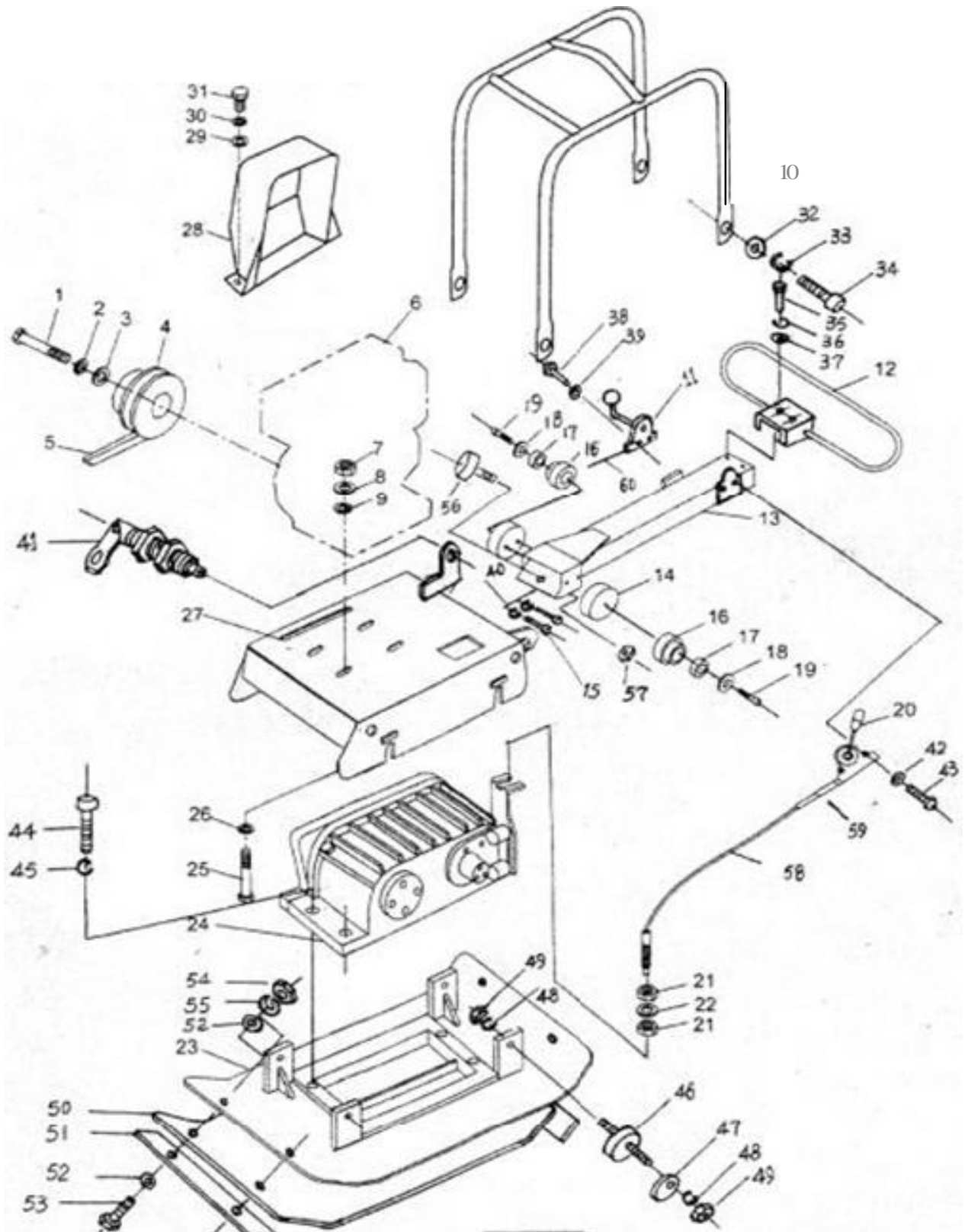



## KPRC160 PARTS LIST

ITEM NO.	PART NO.	DESCRIPTION	QUANTITY
1	160001	BOLT M8×25-GB5783	1
2	160002	SPRING WASHER 8-GB93	1
3	160003	FLAT WASHER 8-GB97.1	1
4	160004	ENGINE PULLEY ASSEMBLY FOR DIESEL	1
5	160005	V-BELT FOR DEISEL ENGINE	1
6	160006	ENGINE	1
7	160007	NUT M8-GB41	4
8	160008	SPRING WASHER 10-GB93	4
9	160009	FLAT WASHER 10-GB97.1	4
10	160010	FRAME ASSEMBLY	1
11	160011	THROTTLE CONTROL LEVER	1
12	160012	GRIP HANDLE	1
13	160013	HANDLE	1
14	160014	RUBBER ABSORBER	2
15	160015	BOLT M8×25-GB70	4
16	160016	NYLON COLLAR	2
17	160017	STEEL RING	2
18	160018	FLAT WASHER	2
19	160019	BOLT M12×65-GB5783	2
20	160020	REVERSE LEVER	1
21	160021	NUT M14-GB41	2
22	160022	FLAT WASHER 14-GB95	2
23	160023	BASE PLATE 73×37 • 73x50 • 73x37+2x90	1
24	160024	VIBRATOR ASSEMBLY	1
25	160025	BOLT M8×45-GB5781	4
26	160026	FLAT WASHER 10-GB97.1	4
27	160027	ENGINE MOUNTING PLATE	1
28	160028	BELT GUARD	1
29	160029	FLAT WASHER 8-GB97.1	2
30	160030	SPRING WASHER 8-93	2
31	160031	BOLT M8×20-GB70	2
32	160032	FLAT WASHER 8-GB97.1	4
33	160033	SPRING WAHSER 8-93	4
34	160034	BOLT M10×35-GB5780	4
35	160035	BOLT M10×35-GB5781	2
36	160036	SPRING WASHER 10-GB93	2
37	160037	FLAT WASHER 10-GB97.1	2
38	160038	BOLT M6×40-GB70	2
39	160039	FLAT WASHER 6-GB97.1	2
40	160040	SPRING WASHER 8-GB93	4
41	160041	HANDLE LOCK ASSEMBLY	1
42	160042	FLAT WASHER 6-GB97.1	2
43	160043	BOLT M6×40-GB70	2
44	160044	BOLT M18×55-GB70	4
45	160045	SPRING WASHER 18-GB93	4
46	160046	VIBRATION ABSORBER	4
47	160047	ADJUSTING PLATE	4
48	160048	SPRING WASHER 12-GB93	8
49	160049	NUT M12-GB8164	8
50	160050	RUBBER PLATE	1
51	160051	FIXING PLATE	2

ITEM NO.	PART NO.	DESCRIPTION	QUANTITY
52	160052	FLAT WASHER 10-GB97.1	8
53	160053	BOLT M10×45-GB5780	4
54	160054	NUT M10-GB6184	4
55	160055	SPRING WASHER 10-GB93	4
56	160056	EXTENSION PLATE	2
57	160057	FLAT WASHER 18-GB95	6
58	160058	SPRING WASHER 18-GB93	6
59	160059	BOLT M18×55-GB5780	6
60	160060	TRANSPORT WHEEL ASSEMBLY	1
4	160004	ENGINE PULLEY ASSEMBLY	1
61	160004-1	CIRCLIP INT80-GB893.1	1
62	160004-2	CIRCLIP EXT40-GB894.1	1
63	160004-3	DRUM	1
64	160004-4	BEARING 60208-GB276	1
65	160004-5	CENTRIFUGAL LUMP	3
66	160004-6	CLUTCH CENTRE FOR DIESEL	1
		CLUTCH CENTRE FOR PETROL	1
67	160004-7	CLUTCH SPRING	2
68	160068	CHANGEMENT CONTROL WIRE	1
69	160069	THROTTLE CONTROL WIRE	1
70	160070	RUBBER ABSORBER	1

KPRC160 PLATE COMPACTOR DIAGRAM

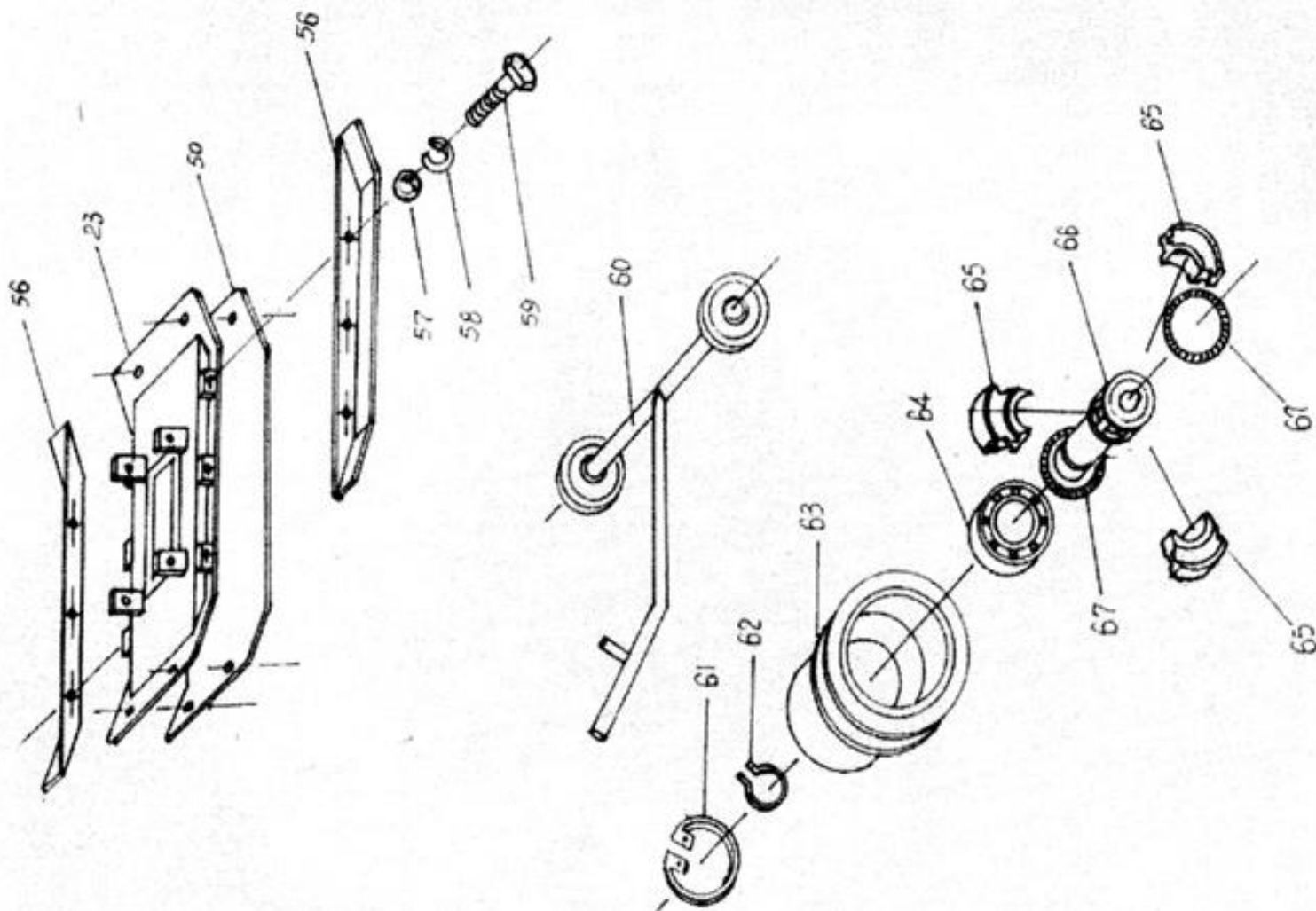

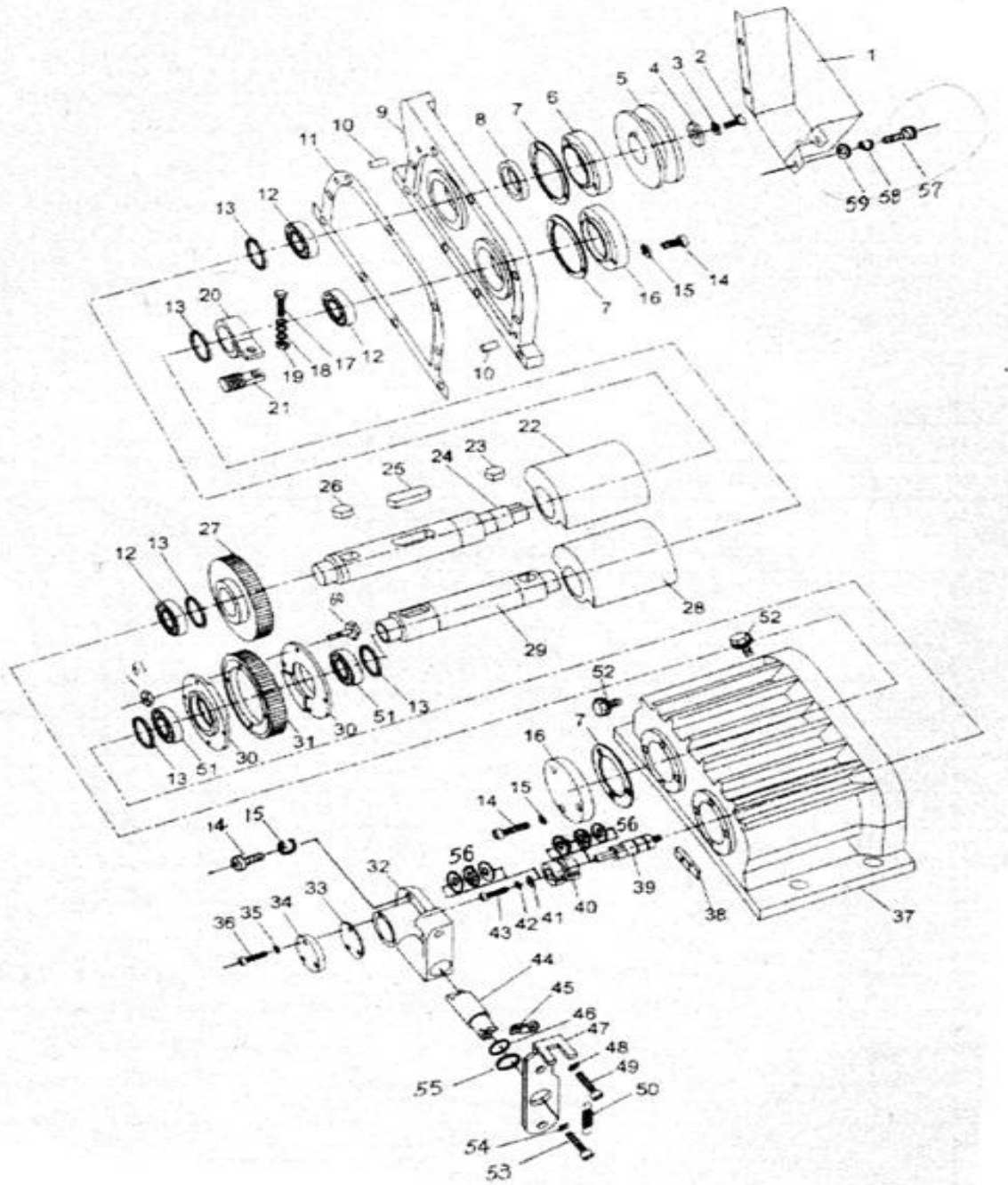

**KPRC160 PARTS LIST**

ITEM NO.	PART NO.	DESCRIPTION	QUANTITY
1	160024-1	BELT COVER	1
2	160024-2	BOLT M8X25-GB5783	1
3	160024-3	SPRING WASHER 8-GB93	1
4	160024-4	FLAT WASHER 8-GB97.1	1
5	160024-5	PULLEY	1
6	160024-6	BEARING COVER	1
7	160024-7	PACKING FOR BEARING COVER	4
8	160024-8	OIL SEAL 50X28X10	1
9	160024-9	BOX COVER	1
10	160024-10	LOCKING PIN8-GB120	2
11	160024-11	PACKING FOR BOX-COVER	1

**KPRC160 PARTS**

<b>ITEM NO.</b>	<b>PART NO.</b>	<b>DESCRIPTION</b>	<b>QUANTITY</b>
12	160024-12	BEARING 42206-GB283	4
13	160024-13	STOP RING 42-GB894.1	5
14	160024-14	BOLT M8X25-GB70	22
15	160024-15	SPRING WASHER 8-GB93	22
16	160024-16	BEARING COVER	2
17	160024-17	BOLT M10X55-GB5782	1
18	160024-18	BUFFER SPRING	1
19	160024-19	NUT M10-GB6182	1
20	160024-20	PINCH CLAMP	1
21	160024-21	SPIKE DOWEL M20X30-21	1
22	160024-22	ECCENTRIC ROTATOR	1
23	160024-23	KEY C8X20-GB1096	1
24	160024-24	PULLEY DRIVING SHAFT	1
25	160024-25	KEY A12X50-GB1096	1
26	160024-26	KEY A12X50-GB1096	1
27	160024-27	GEAR	1
28	160024-28	ECCENTRIC ROTATOR	1
29	160024-29	DRIVING SHAFT	1
30	160024-30	CHANGEMENT COUPLING	2
31	160024-31	GEAR	1
32	160024-32	DIRECTION HOUSING	1
33	160024-33	PACKING	1
34	160024-34	COVER	1
35	160024-35	SPRING WASHER 6-GB93	3
36	160024-36	BOLT M6X16-GB70	3
37	160024-37	VIBRATION BOX	1
38	160024-38	DIRECTION PIN	1
39	160024-39	SPINDLE	1
40	160024-40	SLIDING SLEEVE	1
41	160024-41	FLAT WASHER 5-GB97.1	1
42	160024-42	SPRING WASHER 5-GB93	1
43	160024-43	BOLT M5X25-GB70	1
44	160024-44	SPINDLE	1
45	160024-45	LEVER	1
46	160024-46	O-RING 22×4-GB3452	3
47	160024-47	HOLDER	1
48	160024-48	SPRING WASHER 10-GB93	2
49	160024-49	BOLT M10×30-GB70	2
50	160024-50	SPRING	1
51	160024-51	BEARING 16008-GB276	2
52	160024-52	OIL PLUG M14×1.5	2
53	160024-53	BOLT M8×25-GB70	1
54	160024-54	SPRING WASHER 8-GB93	1
55	160024-55	STEEL RING	1
56	160024-56	BEARING	2
57	160024-57	BOLT M8×20-GB70	4
58	160024-58	SPRING WASHER 8-GB93	4
59	160024-59	FLAT WASHER 8-GB97.1	4

