

ART5003 Assembly Instructions

Greene Galvanized Stairs

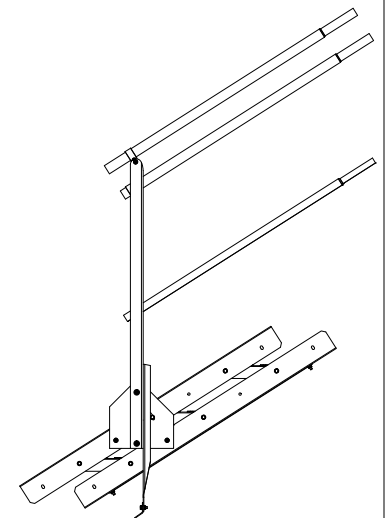
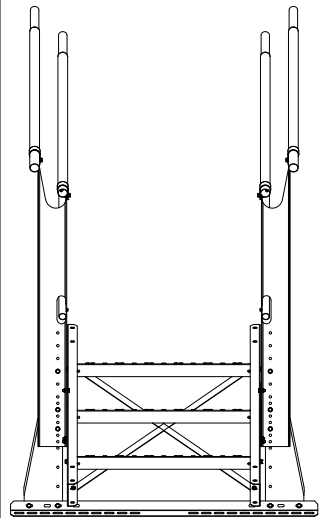

Parts List

PARTS LIST		
PART NUMBER	DESCRIPTION	QTY
5/16-18x3/4FB	5/16"-18 x 3/4" Flange Bolt	38
5/16-18SFN	5/16"-18 Whiz Lock Nut	38
ES-5015	Easy Step Roof Stair Mount	1
ART-1015	Right Stair Post w/Guardrail	1
ART-1016	Left Stair Post w/Guardrail	1
ART-1004	Roof Stair Post Brace Right	1
ART-1007	Roof Stair Post Brace Left	1
ART-1011	Roof Stair Leveling Plate	2
ART-5003	3-Step Side Rail	4
AS-00030	30" x 11" Stair Step Tread	3
ART-1001	Stair Stringer X-Brace	2
TR1504606	46" 1.5" Swaged Tubing 6" Swage	4
TR1004606	46" 1" Swaged Tubing 6" Swage	2
HRC1500	1.5" P-Clamp for Handrail	4
Floor Screw	Self-Tapping Screw	6

Parts List

ES-5015

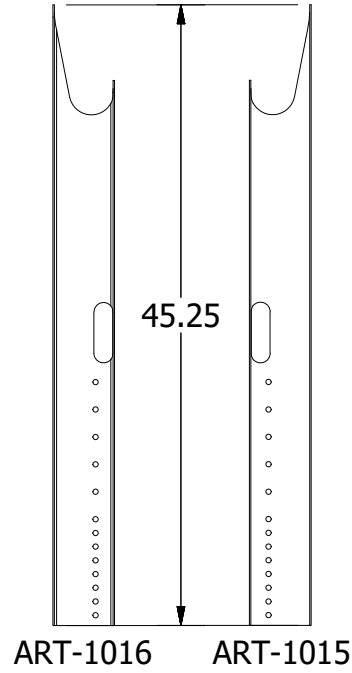
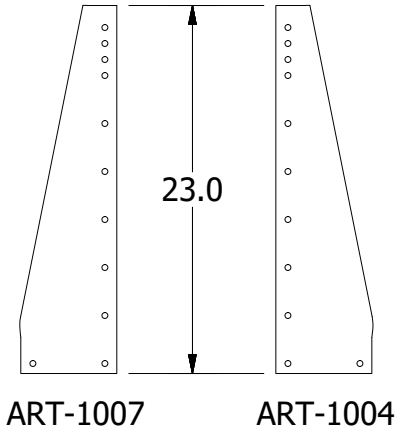
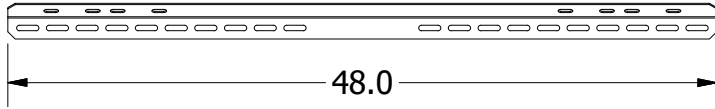

HRC1500

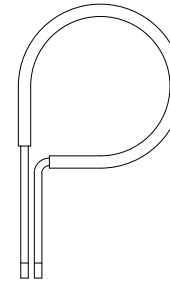

ART-1011

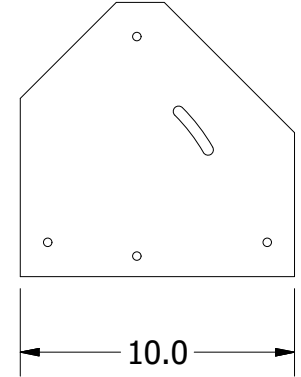

TR1504606

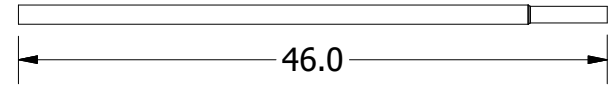

TR1004606

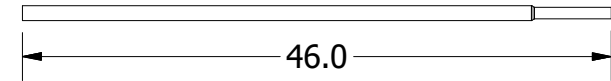

AS00030

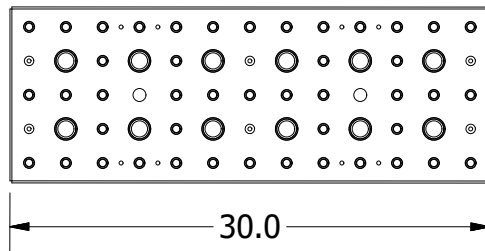

ART-5003

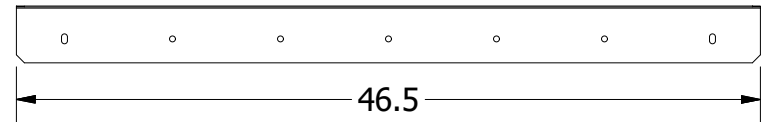

5/16-18x3/4FB

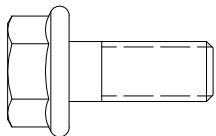

1:1

5/16-18SFN

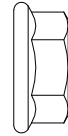

1:1

Floor Screw

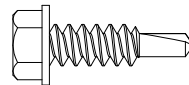

1:1

ART-1001

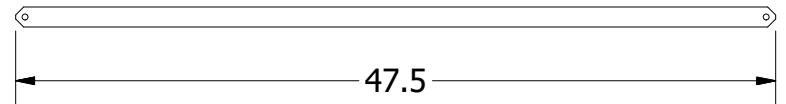

Step 1

- Place the ART-1007 and ART-1004 braces against the ES-5015 Roof Mount as shown in Figure 1. The braces' flanges will face up the roof run when installed.
- Secure the braces to the roof mount using four (4) 5/16" Flange Bolts and four (4) 5/16" Lock Nuts. See Detail A for bolt hole locations on the ES-5015 brace.
- Place the ART-1015 and ART-1016 posts against the ART-1007 braces. The bolt spacing shown in Figure 2 are in the lowest position; adjust the height to fit the roof.
- Secure each in place with three (3) 5/16" Flange Bolts and three (3) 5/16" Lock Nuts.

DETAIL A

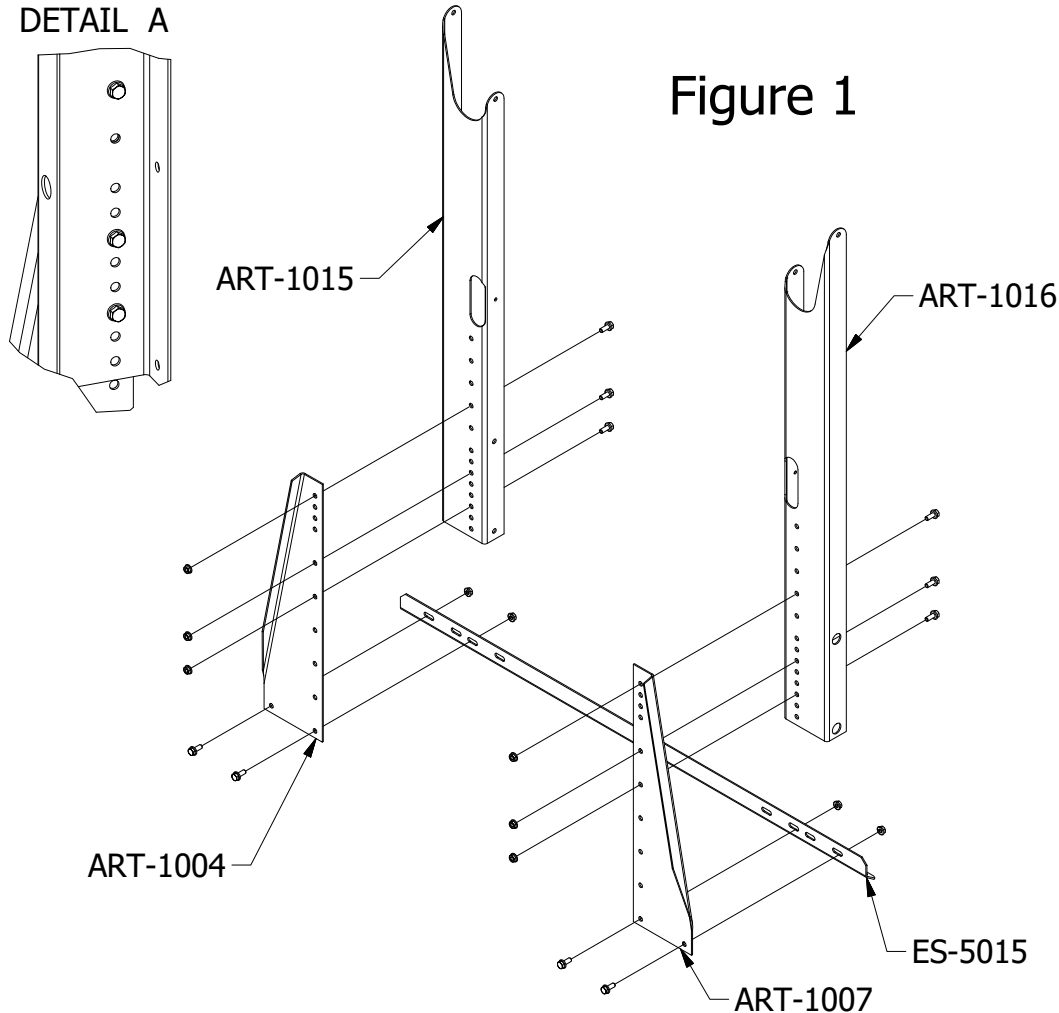
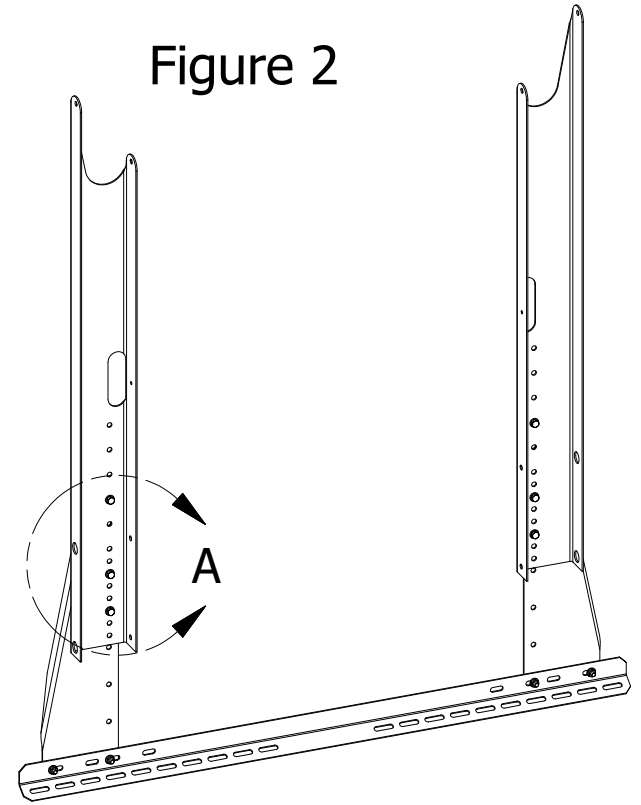

Figure 1

Figure 2



PARTS USED IN STEP 1		
PART NUMBER	DESCRIPTION	QTY
ES-5015	Easy Step Roof Stair Mount	1
ART-1007	Roof Stair Post Brace Left	1
ART-1004	Roof Stair Post Brace Right	1
ART-1015	Right Stair Post	1
ART-1016	Left Stair Post	1
5/16-18x3/4FB	5/16"-18 x 3/4" Flange Bolt	10
5/16-18SFN	5/16"-18 Whiz Lock Nut	10

DRAWN Marcus Wilmsmeyer	1/17/2019	Greene Galvanized Stairs East Lynn, IL 217.375.4244 www.greenebinstairs.com	
CHECKED		TITLE A-Series Roof Stairs - 3-Step Assembly Instructions	
QA		SIZE A	DWG NO IN-ART5003
MFG		SCALE 1/14	REV
APPROVED		SHEET 4 OF 9	

Step 2

- A. Take two (2) ART-1011 Levelling Brackets and attach them to the ART-1015 and ART-1016 posts as shown in Figure 3 and Figure 4.
- B. Secure the brackets in place using four (4) 5/16" Flange Bolts and four (4) 5/16" Lock Nuts.

PARTS USED IN STEP 2		
PART NUMBER	DESCRIPTION	QTY
5/16-18x3/4FB	5/16"-18 x 3/4" Flange Bolt	4
5/16-18SFN	5/16"-18 Whiz Lock Nut	4
ART-1011	Roof Stair Leveling Plate	2

Figure 3

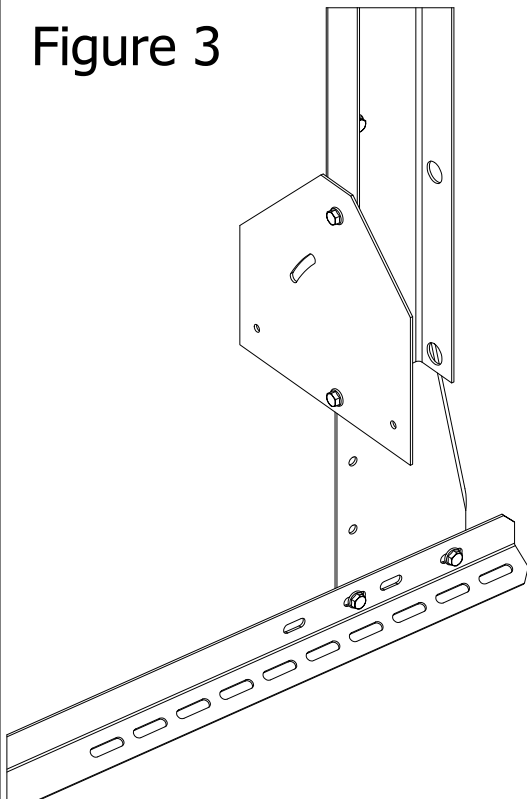
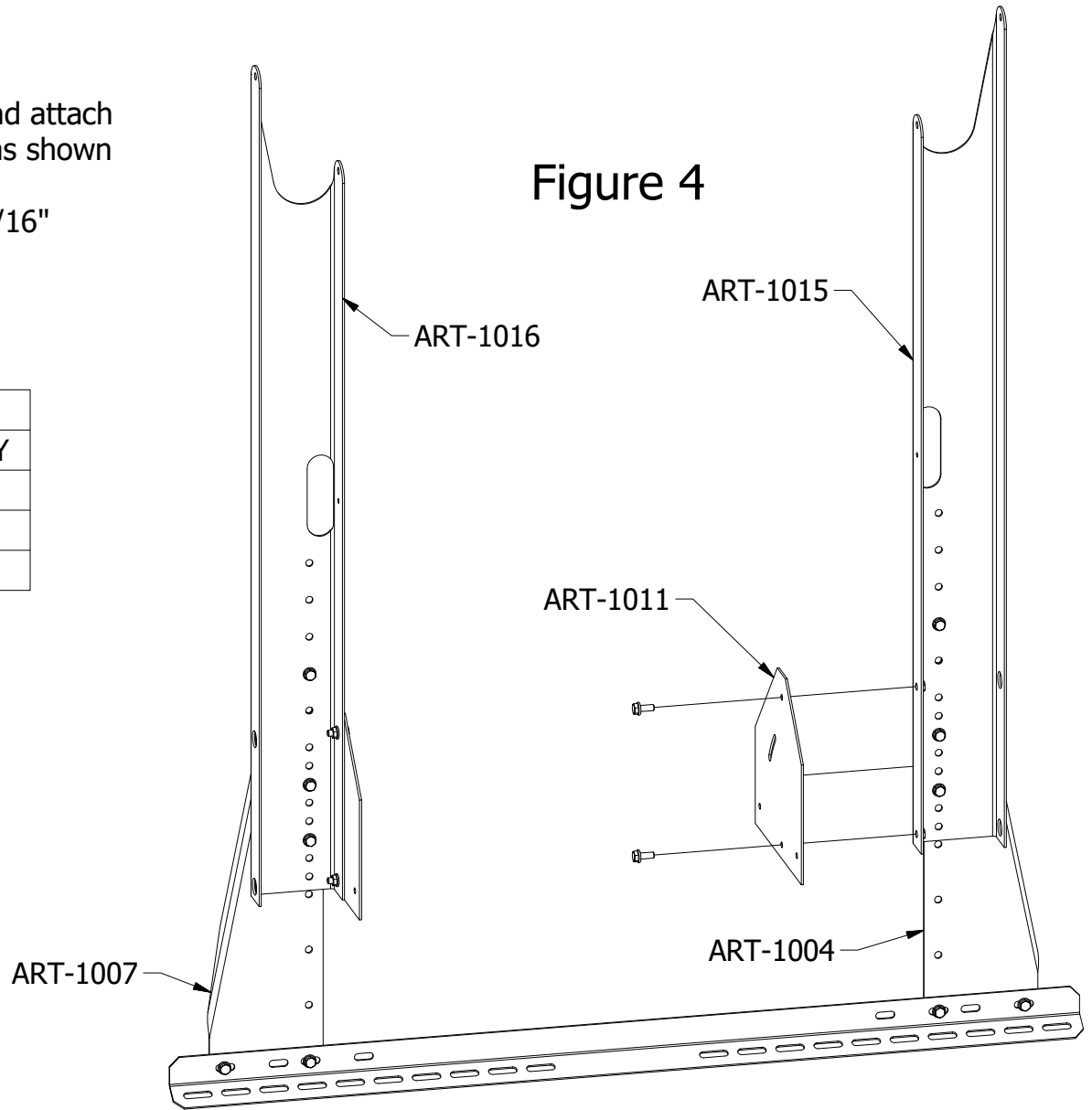

Figure 4



DRAWN Marcus Wilmsmeyer	1/17/2019	Greene Galvanized Stairs East Lynn, IL 217.375.4244 www.greenebinstairs.com	
CHECKED		TITLE A-Series Roof Stairs - 3-Step Assembly Instructions	
QA		SIZE A	DWG NO IN-ART5003
MFG		SCALE 1/9	REV
APPROVED		SHEET 5 OF 9	

Step 3

- A. Place three (3) AS00030 Step Treads in line with four (4) ART-5003 Siderails as shown in Figure 5.
- B. Using ten (10) 5/16" Flange Bolts and ten (10) 5/16" Lock Nuts, secure the step treads to the siderails. On the second-lowest stair, omit two of the bolts and nuts; they will be added on a later step.

PARTS USED IN STEP 3		
PART NUMBER	DESCRIPTION	QTY
ART-5003	3-Step Side Rail	4
AS00030	30" x 11" Step Tread	3
5/16-18x3/4FB	5/16"-18 x 3/4" Flange Bolt	10
5/16-18SFN	5/16"-18 Whiz Lock Nut	10

Figure 5

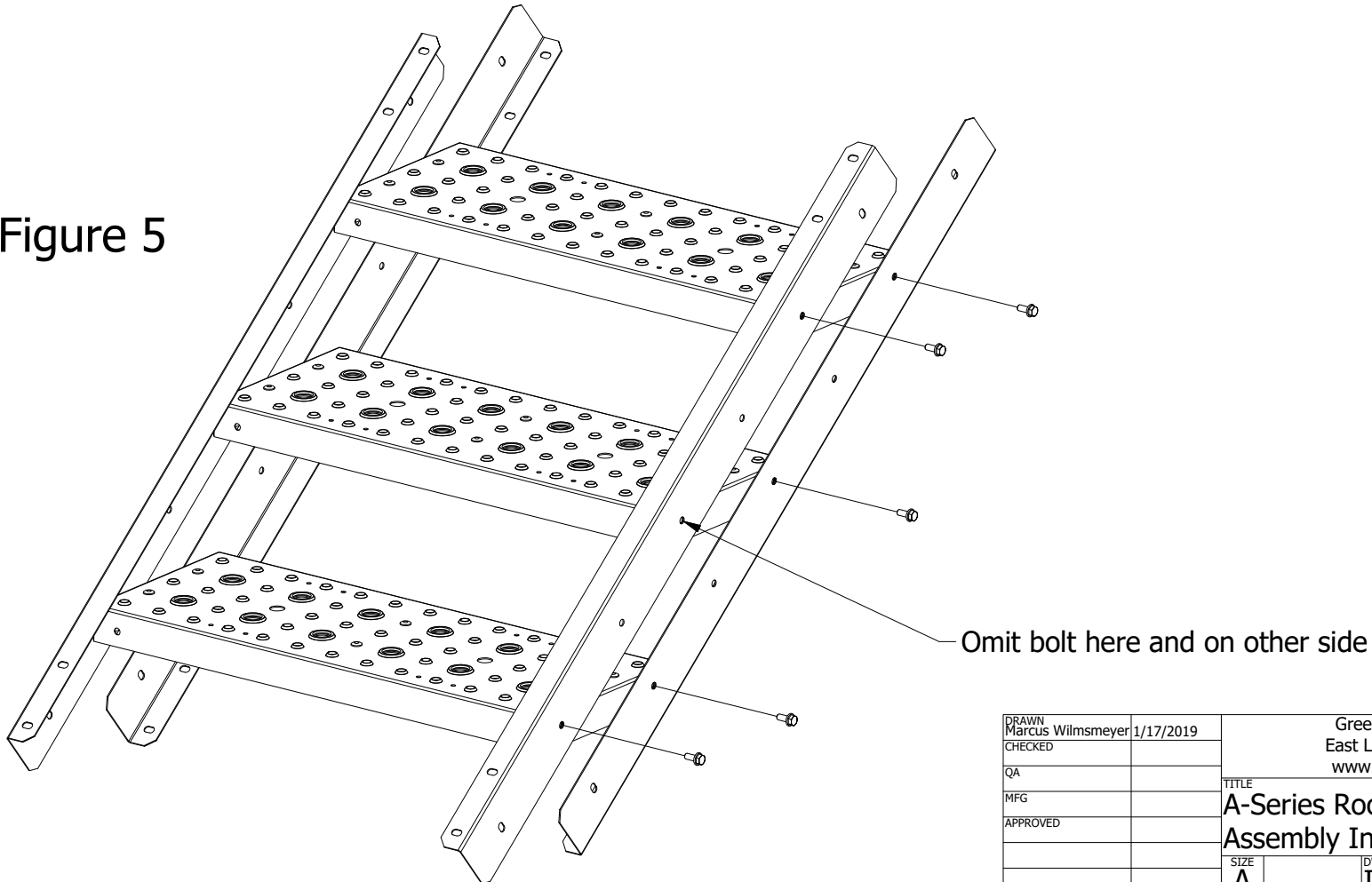

DRAWN Marcus Wilmsmeyer	1/17/2019	Greene Galvanized Stairs East Lynn, IL 217.375.4244 www.greenebinstairs.com	
CHECKED		TITLE	
QA		A-Series Roof Stairs - 3-Step Assembly Instructions	
MFG		SIZE	DWG NO
APPROVED		A	IN-ART5003
		SCALE	REV
		1/9	
		SHEET	6 OF 9

Step 4

- A. Take the two (2) Cross Braces and position them on the bottom of the stair assembly as shown in Figure 6. On an ART5003, these braces will line up with the second bolt from the end on the siderails.
- B. Secure in place with four (4) 5/16" Flange Bolts and four (4) 5/16" Lock Nuts.

Figure 6

DETAIL B

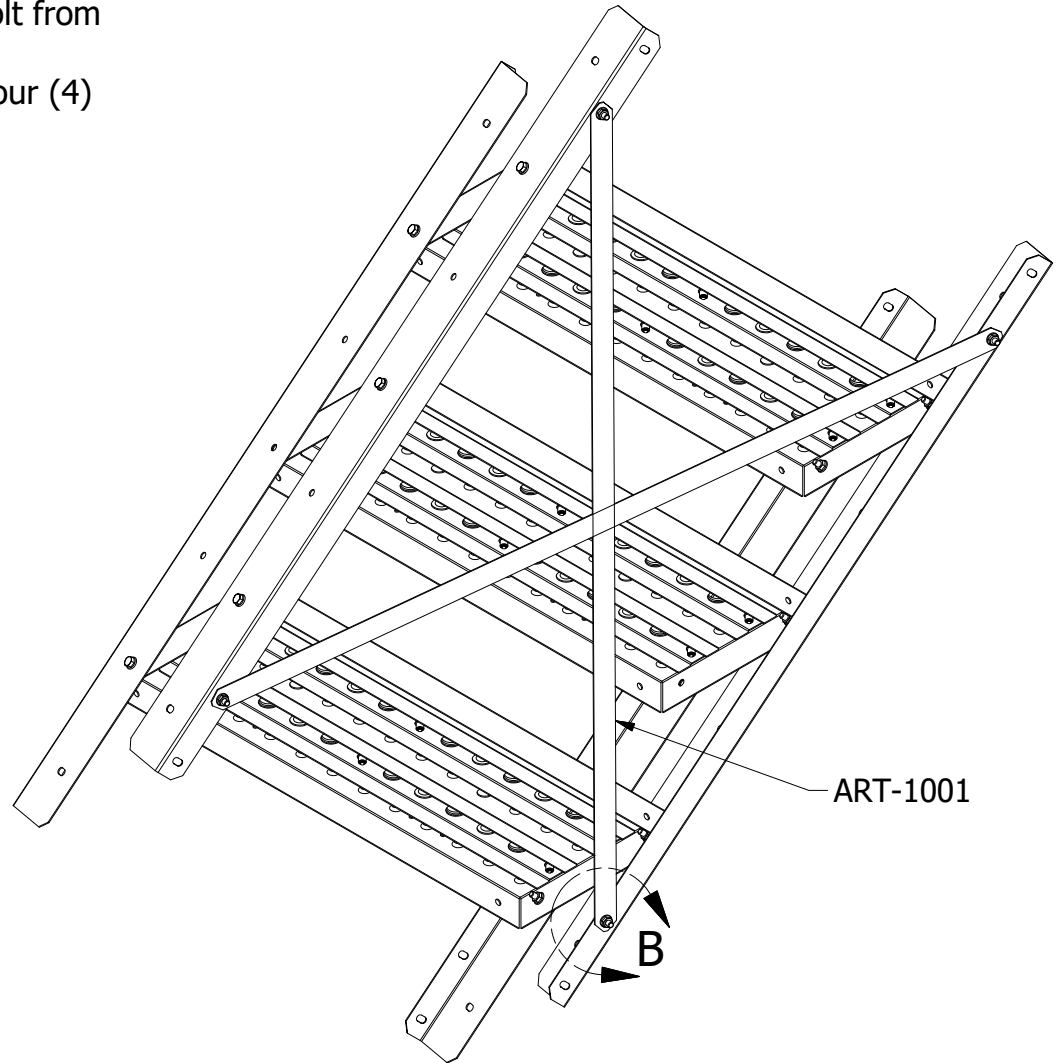
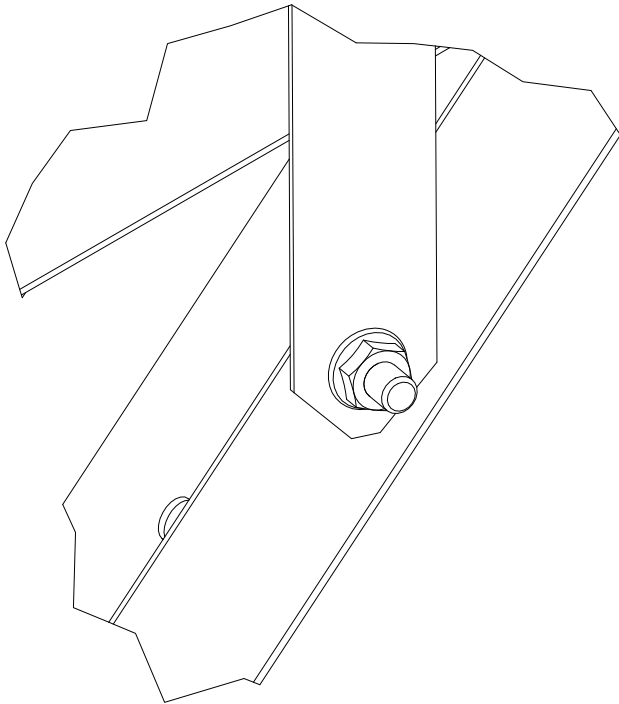

PARTS USED IN STEP 4		
PART NUMBER	DESCRIPTION	QTY
5/16-18x3/4FB	5/16"-18 x 3/4" Flange Bolt	4
5/16-18SFN	5/16"-18 Whiz Lock Nut	4
ART-1001	Roof Stair Cross Brace	2

DRAWN Marcus Wilmsmeyer	1/17/2019	Greene Galvanized Stairs East Lynn, IL 217.375.4244 www.greenebinstairs.com	
CHECKED		TITLE A-Series Roof Stairs - 3-Step Assembly Instructions	
QA		SIZE A	DWG NO IN-ART5003
MFG		SCALE 1/10	REV
APPROVED		SHEET 7 OF 9	

Step 5

- A. Using six (6) 5/16" Flange Bolts and six (6) 5/16" Lock Nuts, bolt the siderails to the leveling bracket. Review Figures 7 and 8 for the bolt layout.
- B. Tighten the bolts on the leveling plates after the final placement on the roof.

PARTS USED IN STEP 5		
PART NUMBER	DESCRIPTION	QTY
5/16-18x3/4FB	5/16"-18 x 3/4" Flange Bolt	6
5/16-18SFN	5/16"-18 Whiz Lock Nut	6

Figure 7

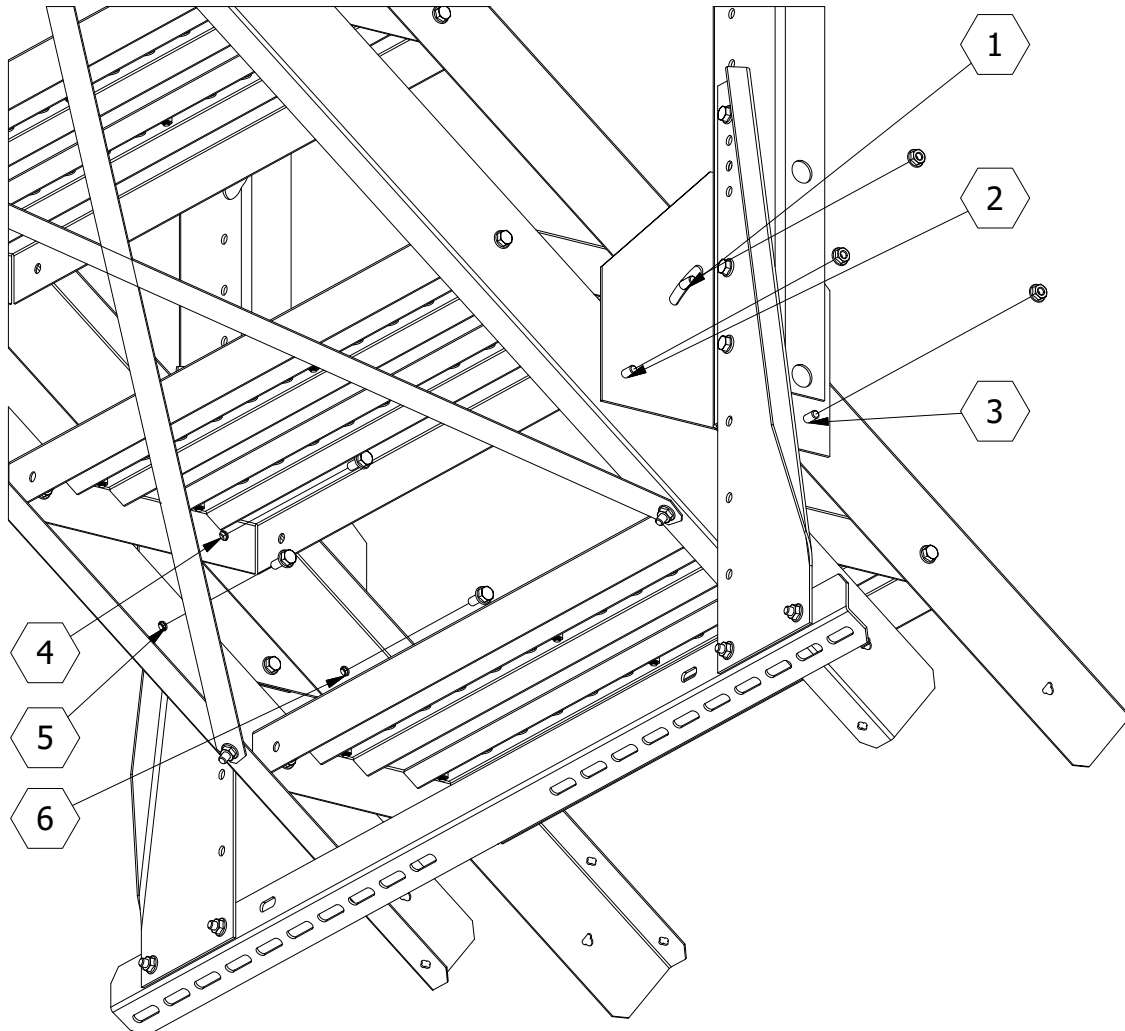
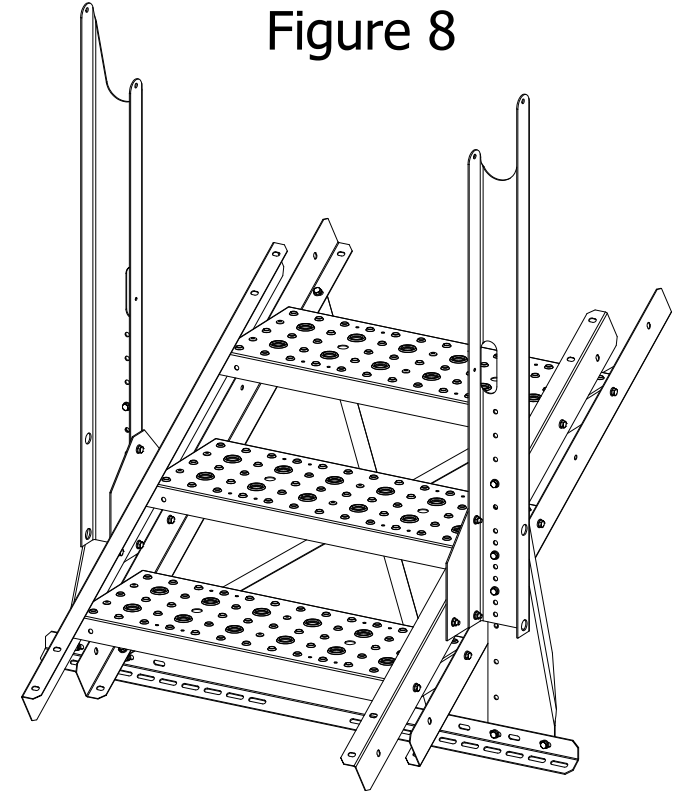

Figure 8



DRAWN Marcus Wilmsmeyer	1/17/2019	Greene Galvanized Stairs East Lynn, IL 217.375.4244 www.greenebinstairs.com	
CHECKED		TITLE A-Series Roof Stairs - 3-Step Assembly Instructions	
QA		SIZE A	DWG NO IN-ART5003
MFG		SCALE 1/7	REV
APPROVED		SHEET 8 OF 9	

Step 6

- A. Taking the four (4) TR1506006 Swaged Pipes (1.5" dia.), position the pipes as shown in Figure 9, Detail C. Secure the pipes to the posts using four (4) HRC1500 P-Clamps, four (4) 5/16" Flange Bolts, and four (4) 5/16" Lock Nuts.
- B. After the four TR1506006 have been position to the desired location, use four (4) Self-Tapping Screws and secure the 1.5" pipe to the P-Clamp. The screws should be drilled through the bottom of the P-clamp, to minimize interference with hands.
- C. Take the two (2) TR1006006 Swaged Pipes (1" dia.), and position them as shown in Figure 9, Detail D. Secure them to the posts by using two (2) Self-Tapping Screws. There is a hole on the post to aid in starting the Self-Tapping Screw.

Figure 9

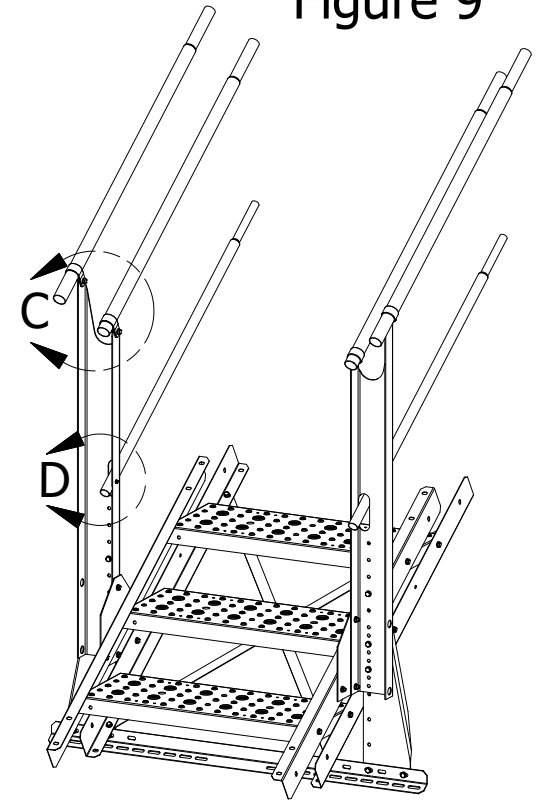

DETAIL C

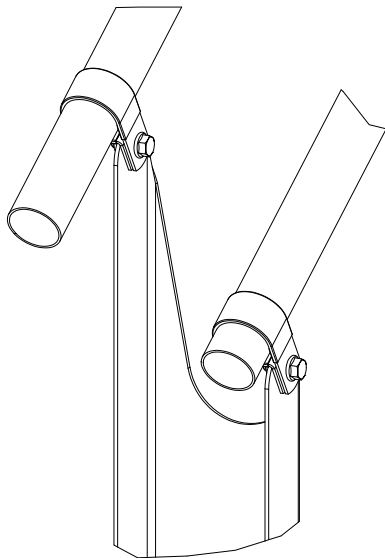

DETAIL D

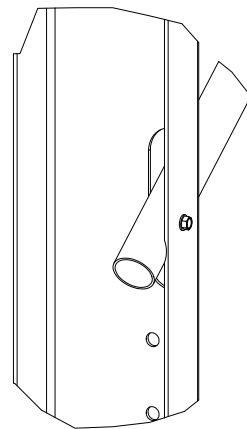

PARTS USED IN STEP 6

PART NUMBER	DESCRIPTION	QTY
5/16-18x3/4FB	5/16"-18 x 3/4" Flange Bolt	4
5/16-18SFN	5/16"-18 Whiz Lock Nut	4
HRC1500	1.5" Handrail P-Clamp	4
Floor Screw	Self-Tapping Screw	6
TR1506006	1.5" Handrail, Swaged	4
TR1006006	1" Handrail, Swaged	2

DRAWN Marcus Wilmsmeyer CHECKED QA MFG APPROVED	1/17/2019	Greene Galvanized Stairs East Lynn, IL 217.375.4244 www.greenebinstairs.com
		TITLE A-Series Roof Stairs - 3-Step Assembly Instructions
		SIZE A
		DWG NO IN-ART5003
		SCALE 1/22
		SHEET 9 OF 9