

Sustainable Coils LLC

Replacement Coil Solutions!

EPA-EXA REPLACEMENT A-COILS

Revision date: 10/09/2023

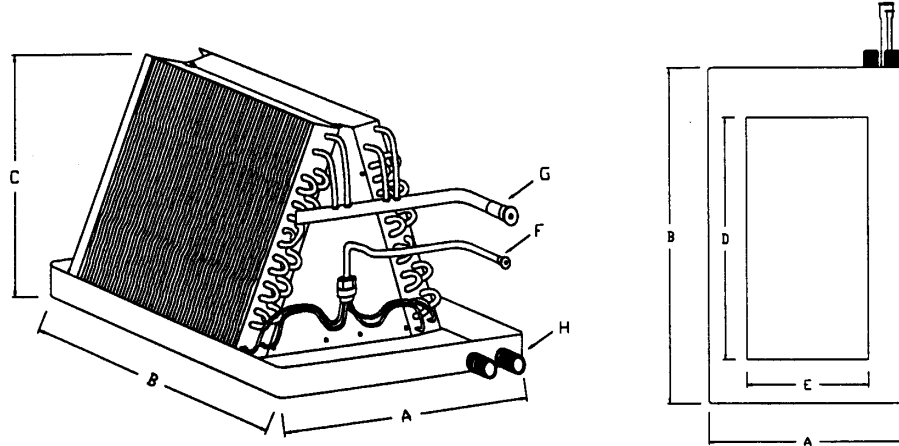

COIL MODEL	COIL WEIGHT	ROWS	A	B	C	D	E	F	G	H
**RC-EPA24B15	26	3	14 3/4	19 3/4	10 1/2	15 3/4	7 1/2	3/8	3/4	3/4
RC-EXA24B15	34	3	14 3/4	19 3/4	14 1/2	15 3/4	7 1/2	3/8	3/4	3/4
**RC-EPA36B15	41	3	14 3/4	19 3/4	18 1/2	15 3/4	7 1/2	3/8	3/4	3/4
**RC-EPA36F19	42	3	18 1/8	19 3/4	18 1/2	15 3/4	10 3/4	3/8	3/4	3/4
RC-EXA36B15	41	3	14 3/4	19 3/4	18 1/2	15 3/4	7 1/2	3/8	3/4	3/4
RC-EXA36F19	42	3	18 1/8	19 3/4	18 1/2	15 3/4	10 3/4	3/8	3/4	3/4
RC-EPA42F19	42	3	18 1/8	19 3/4	18 1/2	15 3/4	10 3/4	3/8	7/8	3/4
RC-EPA48F19	46	3	18 1/8	19 3/4	20 1/2	15 3/4	10 3/4	3/8	7/8	3/4
RC-EPA48J22	49	3	21 7/8	19 3/4	22 1/2	15 3/4	14 1/2	3/8	7/8	3/4
**(*)RC-EPA60J22	56	4	21 7/8	19 3/4	20 1/2	15 3/4	12 3/4	3/8	7/8	3/4

Suction line 1 5/8" ←, 10 5/8" ↑. Liquid line 1 5/8" ←, 9 3/8" ↑.
 Primary drain 2 1/2" ← to center, secondary drain 1 5/8" ← to center.

3/8" O.D., CU-122 60 helical copper tube, .016 back wall.

2,500 PSI burst pressure minimum

Aluminum end plates to protect against rust corrosion

22 ga. G-90 paint grip metal drain pan, coated with a rust inhibitor and painted black

RC-EPA piston metered for R-22 application, RC-EXA equipped with R-22 heat pump TXV

Pre-swaged refrigerant connections, shipped with dry nitrogen holding charge

Five year replacement warranty

(*) Denotes overweight/oversize coil that must be shipped on a skid to a commercial location.

** Denotes physical dimension modification from original 2 row coils to 3 row coils, or 3 row coils to 4 row coils.

Telephone: (903) 881-6006

Fax: (903) 881-6008

email: sales@SustainableCoils.com

Sustainable Coils LLC

Replacement Coil Solutions!

EPA - EXA Replacement Coils Cross Reference 10/09/2023

CROSS REFERENCE UTILIZATION CHART

OEM Model #	Sustainable Model #	Specified Metering
EPA24B15	**RC-EPA24B15	R-22 PISTON
EPA36B15	**RC-EPA36B15	R-22 PISTON
EPA36F19	**RC-EPA36F19	R-22 PISTON
EPA42F19	RC-EPA42F19	R-22 PISTON
EPA48F19	RC-EPA48F19	R-22 PISTON
EPA48J22	RC-EPA48J22	R-22 PISTON
EPA60J22	**RC-EPA60J22	R-22 PISTON
EPA60N26	Out of production	R-22 PISTON

OEM Model #	Sustainable Model #	Specified Metering
EXA24B15	RC-EXA24B15	R-22 HP-TXV
EXA36B15	RC-EXA36B15	R-22 HP-TXV
EXA36F19	RC-EXA36F19	R-22 HP-TXV
EXA48J22	RC-EXA48J22	R-22 HP-TXV
EXA60N26	Out of production	R-22 HP-TXV

OEM Model #	Sustainable Model #	Specified Metering
(N)FCP2400C/D	**RC-EPA24B15	R-22 PISTON
(N)FCP3000C/D	**RC-EPA36B15	R-22 PISTON
(N)FCP3600C/D	**RC-EPA36F19	R-22 PISTON
(N)FCP4200C/D	**RC-EPA42F19	R-22 PISTON
(N)FCP4800C/D	RC-EPA48J22	R-22 PISTON
(N)FCP6000C/D	No Replacement Option	R-22 PISTON

OEM Model #	Sustainable Model #	Specified Metering
(N)FCX2400C	RC-EXA24B15	R-22 HP-TXV
(N)FCX3600C	RC-EXA36F19	R-22 HP-TXV
(N)FCX4800C	No Replacement Option	R-22 HP-TXV
(N)FCX6000C	No Replacement Option	R-22 HP-TXV

3/8" O.D., CU-122 60 helical copper tube, .016 back wall.

2,500 PSI burst pressure minimum

Aluminum end plates for rust reduction.

EPA coils are piston metered for R-22 applications, additional 410A pistons available.

EXA coils have R-22 expansion valves factory installed, 410A valves available upon request.

Drains, suction and liquid lines are positioned to original OEM specifications.

Pre-swaged suction and liquid lines, shipped with dry nitrogen holding charge.

Coils utilize a coated G-90 paint grip metal drain pan.

Coils carry a Five year replacement warranty.

Proudly manufactured and assembled in Lindale, Texas.

**Denotes models that have been modified (2 row to 3 row, 3 row to 4 row) to meet current production models and facilitate shipping.

Telephone: (903) 881-6006

Fax: (903) 881-6008

email: sales@SustainableCoils.com