

S F D Modular Compressed Air Dryer

Separator Filter Dryer



Does your application depend on a reliable supply of clean, dry air?

Have you explored the options available to you and discovered they are often unreliable, cost-prohibitive, or maintenance intensive?

The **SFD** patented 3 in 1 air dryer incorporates a **Separator**, **Filter**, and **Dryer** in one compact modular design, insuring quality compressed air – free of oil, contaminants, and water. The flexible modular design allows for expansion to accommodate future changes in air system requirements.

A Simple & Effective Solution For Your Compressed Air System

FEATURES

- Three-in-one system removes oil, contaminants, and moisture
- Compact size allows for easy installation and maintenance
- Straightforward design provides reliable, long-term operation
- Typically requires less than 10% regeneration air while others draw up to 20%
- Operates in High or Low ambient temperatures, allowing installation in various environments
- Molecular sieve desiccant, in easy spin-on canisters, with built in particulate after-filter
- 3-5 year average life of molecular sieve media
- Uninterrupted operation in clean, dirty, or dusty conditions
- Environmentally friendly - refrigerant free.
- Condensate drain line is not required
- Power requirement 115 volts AC (20 watts)

COMPLETE MODULAR DRYING SYSTEMS

Dryer Models	Modules Used	Max CFM	Voltage	Max PSI	Weight
SFD20	220E	20	115v AC	175	50 lbs
SFD30	230E	30	115v AC	175	52 lbs
SFD40	240E	40	115v AC	175	54 lbs
SFD50	230E, 220S	50	115v AC	175	102 lbs
SFD60	230E, 230S	60	115v AC	175	104 lbs
SFD70	240E, 230S	70	115v AC	175	106 lbs
SFD80	240E, 240S	80	115v AC	175	108 lbs
SFD100	240E, (2) 230S	100	115v AC	175	158 lbs
SFD120	240E, (2) 240S	120	115v AC	175	162 lbs
SFD160	240E, (3) 240S	160	115v AC	175	216 lbs

E = Electric S = Secondary

150 °F max inlet temperature. 80 - 175 psi operating range.

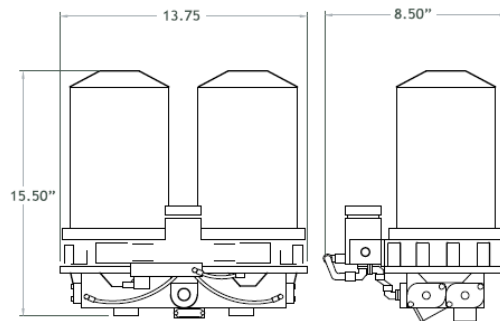
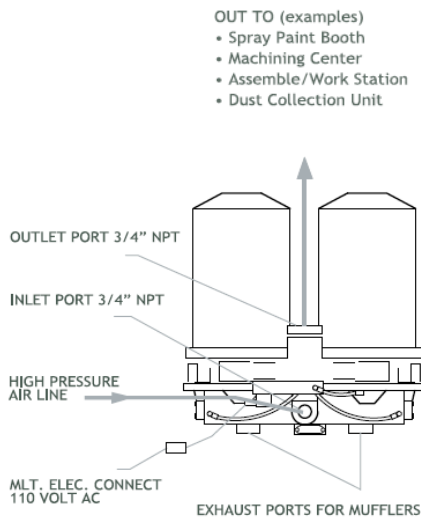

TYPICAL APPLICATIONS

- Automotive Painting (Waterborne)
- Medical Industries
- Dental Industries
- Printing Industries
- Powder Coating
- Clean Rooms
- Concrete Batch Plants
- Tire Inflation (Alternative to Nitrogen)
- Instrumentation Air
- HVAC Controls

SIMPLE INSTALLATION

Expandable Design allows for an increasing air requirement by simply adding additional modular units *

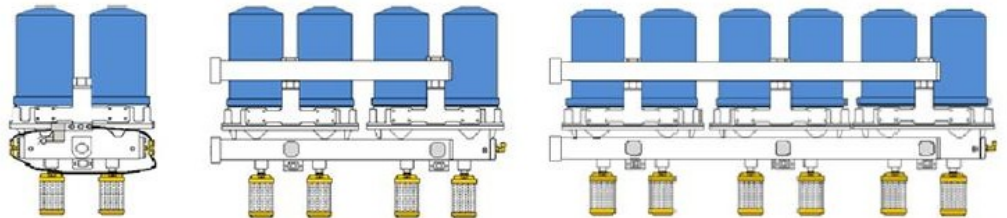

* Optional manifold installation

www.sfdairdryer.com

Available on Request:

- Pneumatic units. Electricity not required
- Mobile units, 12v & 24v DC
- Models with up to 1000 Max CFM
- Special packages and configurations