

# ADC Products

## RS SERIES

-High Precision Rotation Stages-

March 2020



## SPECIFICATIONS

The Precision Mechanical Rotation Stages are precision rotation stages are built upon an industry leading, preloaded, duplexed angular contact bearing set. These stages not only give an exceptionally high running accuracy but allow for large radial and thrust loads as well. Each stage is driven by a precision ground worm gear set and a high resolution, high torque stepper motor. Backlash is reduced by employing a flexure style shimming technique to preload the worm and worm wheel.

### MECHANICAL

Specification	RS100	RS200	RS300	RS400	RS500
Travel Range (°)	+/-360				
Accuracy (μrad)	150	125	125	100	125
Gear Reduction	360:1	356:1	364:1	380:1	260:1
Repeatability (μrad RMS)	1.5	1	1	1	5
Runnout (μm)	7.5	7.5	10	15	15
Load Capacity Radial (kg)	23	39	103	125.5	243.5
Stiffness (μrad/Nm)	1.26	.556	.112	.051	.021

### ELECTRICAL

Motor	Limit Switches	Optical Encoder
2-Phase; 5-Phase Stepper; DC	Mechanical, Normally Closed	Renishaw Tonic Series

### LOAD CHARACTERISTICS

Series	F <sub>x</sub> (N)	F <sub>z</sub> (N)	M <sub>x</sub> (Nm)	M <sub>z</sub> (Nm)
RS100	221	351	26	16
RS200	412	650	62	39
RS300	1015	1627	237	148
RS400	1213	2008	395.5	239
RS500	2390	4050	1130	645

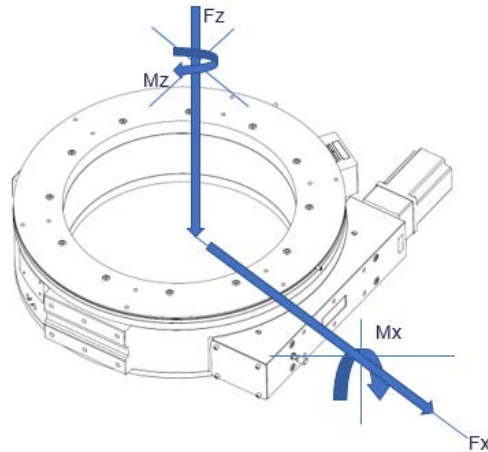

# DIMENSIONS

Top View

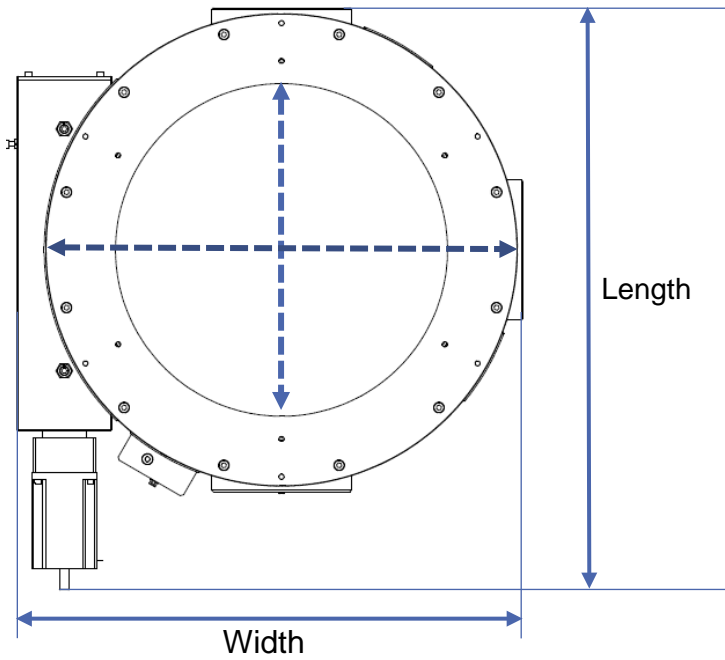

Side View



Model	RS100	RS200	RS300	RS400	RS500
Inner Diameter	100	140	215	300	400
Outer Diameter	165.1	209.5	340	450	625
Length	272	294.25	435	610	770
Width	191	239	367.5	500	670
Height	71.75	94.05	147	158.75	158

## ORDERING INFORMATION

Rotation Stages can be ordered with different configurations. Please use the codes provided below when ordering. Please call or e-mail to ask about any other customization required.

RS (Rotation Stage)	RS100	RS200	RS300	RS400	RS500
<b>Air Preparation Options</b>	-A (Standard Air Stage) -V (Vacuum Stage; ask about options when placing order)				
<b>Encoder Options</b>	-E (With Encoder) -N (Without Encoder)				
<b>Brake Options</b>	-B (With Brake, 24VDC) -N (Without Brake)				
<b>Motor Options</b>	-2PH (Standard 2 Phase Bi-Polar Stepper Motor) -5PH (5 Phase Stepper Motor) -DC (DC Motor)				
<b>Gearbox Option</b>	-G (customer to enter desired ratio; 3:1 to 100:1 available)				

**Example Order:**  
**RS400-A-E-N-2PH**

This is an order for a RS400 Precision Rotation Stage in air, with an encoder, with no brake, a 2-phase motor, and no gearbox.

## OTHER ADC STAGES

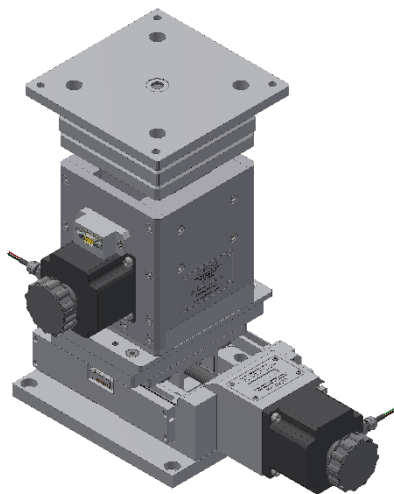

Linear Stages	Lift Stages
DS210	DJ210
DS310	DJ310
DS410	DJ410
DS510	BJ10
	BJ25
Tilt Stages/ Goniometers	Rotation Stages
TS-50	RS-100
TS-90	RS-200
TS-160	RS-300
TS-300	RS-400
TS-400	RS-500
TS-565	
TS-700	

