

RYERSON REALTY LLC

2761 Country Lane Circle
Eagle Grove, IA 50533-0877

Phone 515-448-3079

Fax 515-448-5028

ryerson@goldfielddaccess.net

www.ryersonauctionrealtyltd.com



Deborah D Vance, Broker | Michael Ryerson, Sales | Todd Swalin, Sales

515-689-3715

515-689-3728

515-689-8987

Property Location: 1543 Vincent Ave P-71 Vincent
34-90-27 EG NEWARK TWP SE NW 4.96A
IN SE 1/4

Legal Description:

Price Alone: \$179,900

Approximate Age: 1900

Style: 2 Story

Bedrooms: 3

Siding: Vinyl

Roof Age: unknown

Lot Size: 4.5 Acres

House Sq. Ft: 1,862

Garage: 3 Car Detached

Living Room Flooring: Carpet

Bathroom Main: Full

Basement: 1/2

Furnace: 2025 Forced Air

Central Air: No

24 Mo. Ave. Gas/Elec: vacant

Deck: Yes

Kitchen Details:

Cabinets:	Pine
Frig:	Yes
Stove:	Yes
Dishwasher:	Yes
Garbage Disposal:	No
Dining Space:	No
Flooring:	Pine
Dining Room:	No
Laundry Location:	Main floor
Washer/Dryer:	Yes
Water Heater:	Gas
Elec. Panel:	Breakers
Sump Pump:	Yes
Water Softner:	Yes
Net Taxes:	\$1,746
Terms of Sale/	Cash
Possession:	Closing
2 LP tanks owned	Septic not current
40x40 & 42x54 sheds	

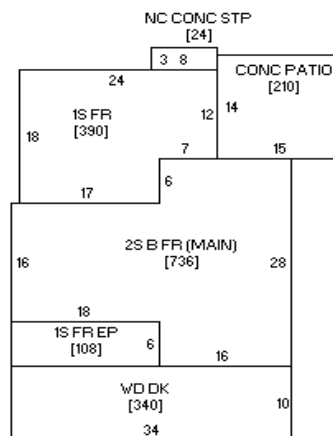

The following information, although believed to be accurate, is not guaranteed to be so. Buyer should do his own inspections. We assume no liability. The measurements are estimates only. This info is subject to change without notice. The seller does not warrant appliances past day of listing.

: we can receive is a personal referral, please tell your friends about us.