

Analysis of Multi Level IUPQC for Voltage Regulation

¹Budharapu Haritha, ²Swetha Bejugam

¹PG Scholar, Department Of Electrical, , Assistant Professor, Department Of Electrical

^{1,2}Sridevi Women's Engineering College, Vattinagulapally, Hyderabad, Telangana

Abstract—This paper presents iUPQC, a Unified Power Quality Conditioner during which the series convertor emulates a Curved current supply and also the shunt convertor emulates a curved voltage supply. This system offers continuous power quality pay of the heap voltage and also the supply current. Latest studies have suggested that the iUPQC has specialized points of interest in correlation with the standard UPQC owing to its lessened shift frequency trademark. This can be accustomed management the ability flow within the transmission by dominant the electrical resistance, voltage magnitude and point. Distinctive in relevance a normal UPQC, the iUPQC has the series convertor controlled as a curved current supply and also the shunt convertor controlled as a curved voltage supply. By increasing no. of levels within the converters, injected voltages or currents gets nearer to sinusoidal during this manner we have a tendency to accomplishes higher doctorate esteem. The execution of the planned system is mimicked in MATLAB/Simulation surroundings.

Keywords—Power Quality, UPFC, Active power filter, Sinusoidal reference, Harmonic content.

I. INTRODUCTION

Unified power internal control was typically reflected by various analyses as a attainable technique to reinforce the standard of power in electrical distribution network [1]. The capability of Unified -power quality conditioner is to get rid of the aggravations that influence the execution of the fundamental load in power framework. As it were, the UPQC has the capability of enhancing power quality at the aim of firm on power appropriation frameworks. The UPQC, hence, is needed to be a standout amongst the foremost effective answers for substantial limit hundreds touchy to provide voltage gleam/unevenness. The UPQC that has 2 inverters that share one dc association, will repay the voltage droop and swell, the harmonious current and voltage, and management the force stream and voltage solidness. Moreover, the UPQC will likewise recompense the voltage intrusion within the event that it's some vitality reposting or battery within the dc be a part of [2]

The UPQC contains of 2 dynamic channels, the arrangement dynamic channel (SAF). The PAF is often controlled as a non curved current supply, that is answerable of repaying the harmonious current of the heap, whereas the

SAF is controlled as a non-sinusoidal voltage supply, that is answerable of remunerating the network voltage. The references to each SAF and PAFs area unit curved, administering the consonant extraction of the matrix current and burden voltage.

The point of this paper is to propose a system for a double 3 stage sure along power quality conditioner (i-UPQC) topology that infuses streams and voltages at higher THD values into utility framework association

II. POWER QUALITY PROBLEM

Power quality has distinctive implications to various people. Institution of Electrical and Electronic Engineers (IEEE) customary IEEE1100 characterizes power quality as “the construct of powering and grounding sensitive equipment in a very manner appropriate for the equipment” [4]. There's a good scope of power quality problems connected with grid frameworks taking under consideration time, as an example, future varieties, transient time varieties and totally different unsettling influences.

Origin of poor power quality

Sources of poor Power Quality are recorded as takes after [5]:

- A. Adjustable –speed drives
- B. Switching Power supplies
- C. Arc heaters
- D. Electronic Fluorescent light weights
- E. Lightning Strike
- F. L-G deficiency
- G. Non- straight load
- H. Starting of extensive engines
- I. Power Electronic drives

III. DUAL UNIFIED POWER QUALITY CONDITIONER

The customary UPQC structure is created out of a SAF and a PAF, as incontestable in Fig. 1. During this setup, the SAF functions as a voltage supply thus on repay the framework disturbances, unbalances, and aggravations like sags, swells, and flicker. During this manner, the voltage repaid by the SAF is created out of a principal part and therefore the harmonics. The PAF functions as a current supply, and it's accountable of repaying the unbalances, displacement, and harmonics of the load current, guaranteeing a curved network current.

The series device channel association with the utility matrix is created through a electrical device, whereas the

shunt channel is often associated squarely to the load, for the most part in low voltage network applications

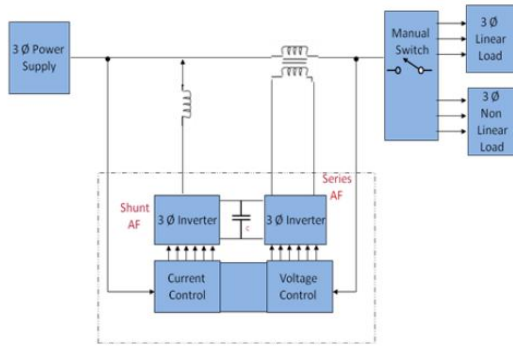

Fig.1: Convectional UPQC

The customary UPQC has the related to disadvantages: complicated harmonic extraction of the grid voltage and therefore the load together with complicated figuring, voltage and current references with harmonic contents obliging a high information measure management, and therefore the spillage inductance of the series association electrical device influencing the voltage compensation made by the series channel. To attenuate these downsides, the iUPQC is examined during this paper, and its arrange is incontestable within the

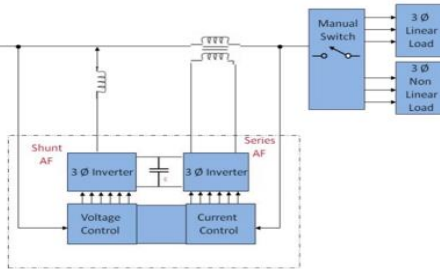

Fig.2: Dual UPQC.

IV. PROPOSED CONTROL SCHEME

The projected iUPQC management structure in associate alphabet reference edge primarily based management, wherever the SAF associated PAF area unit controlled in an autonomous path, indicated in Fig. 3. Within the projected management conspire; the ability computation and harmonic extraction don't seem to be needed following the harmonic, unbalances, disturbances, and displacement to be adjusted. The Series Active Filter (SAF) features a current loop keeping in mind the tip goal to ensure a curving network current synchronic with the network voltage. The PAF features a voltage loop to ensure associate adjusted directed burden voltage with low harmonic bending. These management loops area unit autonomous from each other since they act freely in each dynamic channel. The dc link voltage management is made within the SAF, wherever the voltage loop decides the amplitude reference for this loop,

within the same technique of the ability issue convertor management plans. The curving references for each SAF and PAF controls at created by a processed sign processor, that guarantee the network voltage temporal relation utilizing a PLL as fallows

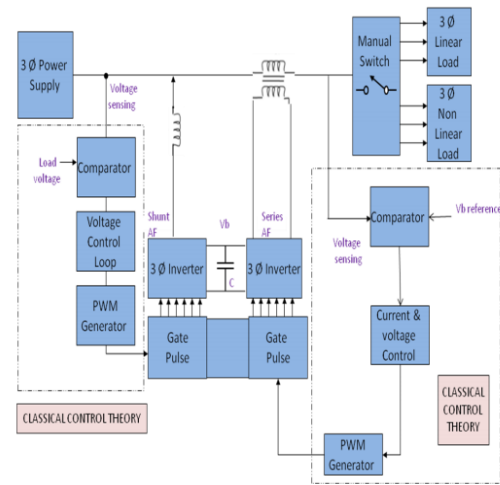

Fig.3: Control of iUPQC

V. SIMULATION RESULTS

The Simulink grew by mathematics Works, is associate data stream graphical programming non-standard speech kit for displaying, recreating and breaking down multi-space dynamic frameworks. Its essential interface may be a graphical block outlining tool associated an adjustable arrangement of block libraries. It offers tight coordination with remainder of the MATLAB surroundings and may either drive MATLAB or be scripted from it. Simulink is generally utilized as a neighborhood of management hypothesis and advanced signal getting ready for multi-space reenactment and Model-Based style. Model of gift framework is incontestable

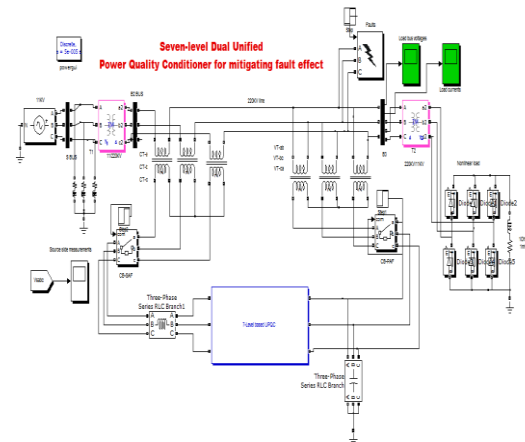

Fig.4: Simulation circuit diagram

The parameters related to the simulation a part of the system area unit given below, supply facet parameters, Series active filter parameters, shunt active filter parameters, THD factor

Source side parameters

AC Supply voltage, $V_s=11\text{KV}$,

Supply frequency, $SF=50\text{Hz}$, 3-Ph

DC link voltage, $V_{dc}=750\text{V}$

Series active power filter parameters

Series Transformer rate=1:3

AC filter, R_F & $C_F=50\text{ohm}$ & $3\mu\text{F}$

AC inductance $L_C=3.5\text{mH}$

Switching frequency, $F_S=10\text{KHz}$

Shunt active power filter parameters

AC inductance $L_A=1\text{mH}$

DC resistance $R_L=100\text{Ohm}$

DC inductance= 10mH

DC capacitor= $2200\mu\text{F}$

VI. WAVEFORMS

A. Input 3-Ph supply voltage $V_s(\text{Volt})$

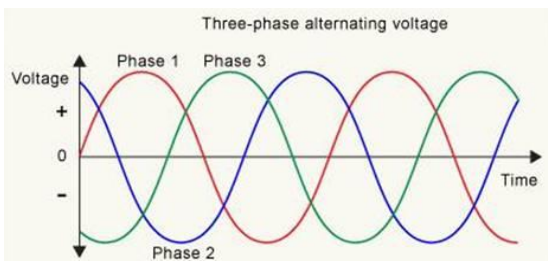

Here we are able to see, drop by the load bus voltages as a result of external disturbances. To eliminate this unwanted situation, inject iUPQC in to the system

B. Load side voltages-With iUPQC

In the presence of iUPQC we can see that voltage dip can be overcome to provide Voltage stability at load bus side

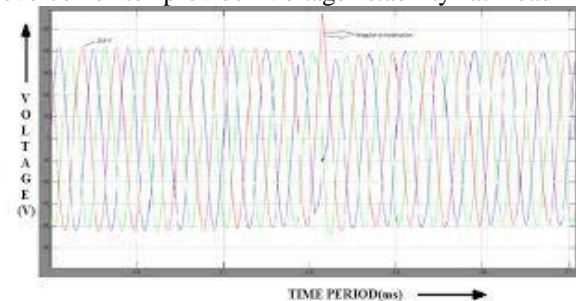

C. Voltage injected by seven-level iUPQC

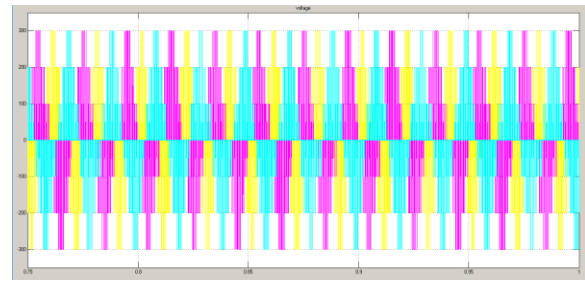

Voltage stability is done by iUPQC is by injecting some voltage into the system.

Harmonic level

THD-total harmonic distortion is that the live of harmonic content within the voltages injected. THD by victimization convectional UPQC=1.023 THD by using gift system=0.734.

Now we will see improvement within the quality of voltage Injected by iUPQC. Percentage improvement within the doctor's degree

$$= (1.407-0.734)/1.407*100 =47.3\%$$

VII. CONCLUSION

The outcomes no inheritable with the iUPQC affirms that the projected ABCs reference edge management lives up to expectations exceptionally well and had the capability remunerating the load unsettling influences what is more guarantee the curved voltage for the load in every of the 3 phases. The dynamic attributes of this framework is watched and skit down utilizing the created MATLAB model. Projected management framework features a good flexibility and solid vigor at no matter purpose the framework is exasperates. The replica model that is dead in an exceedingly explicit approach below MATLAB atmosphere permits mulling over harmonic content within the gift framework contrasted with standard framework.

REFERENCES

- [1]. Akagi, H. and Fujita, H., "A new power line conditional for harmonic compensation in power systems," IEEE Trans. Power Del., vol. 10, no. 3, pp. 1570–1575, Jul. 1995.
- [2]. Fujita, H. and Akagi, H., "The unified power quality conditioner: The integration of series and shunt-active filters," IEEE Trans. Power Electron., vol. 13, no. 2, pp. 315–322, Mar. 1998.
- [3]. H. Akagi, E. H. Watanabe and M. Aredes, Instantaneous Power Theory and Applications to Power Conditioning, Wiley-IEEE Press. April 2007.
- [4]. C. Sankaran, "Power Quality", CRC Press LLC, 2002
- [5]. Alexander Kusko and Marc T.Thompson, "Power Quality in Electrical Systems", McGrawHill, 2007.
- [6]. A. Jindal, A. Ghosh, and A. Joshi, "Interline unified power quality conditioner," IEEE Trans. on Power Delivered., vol. 22, no. 1, pp. 364–372, Jan 2007.
- [7]. Y. Kolhatkar and S. Das, "Experimental investigation of a single-phase UPQC with minimum VA loading," IEEE

Trans. on Power Delivered, vol. 22, no. 1, pp. 373–380, Jan 2007.

- [8]. M. Basu, S. Das, and G. Dubey, “Investigation on the performance of UPQC for voltage sag mitigation and power quality improvement at a critical load point,” IET Generation Transmission Distribution, vol. 2, no. 3, pp. 414–423, May 2008.
- [9]. V. Khadkikar and A. Chandra, “A new control philosophy for a unified power quality conditioner (UPQC) to coordinate load-reactive power demand between shunt and series inverters,” IEEE Trans. on Power Deliv., vol. 23, no. 4, pp. 2522–2534, Oct 2008.
- [10]. M. Aredes and R. Fernandes, “A dual topology of unified power quality conditioner: The iUPQC,” in 13th European Conf. on Power Electron. And Appl., Sept 2009, pp. 1–10.
- [11]. M. Brenna, R. Faranda, and E. Tironi, “A new proposal for power quality and custom power improvement: Open UPQC,” IEEE Trans. on Power Deliv., vol. 24, no. 4, pp. 2107–2116, Oct 2009.
- [12]. S. Chakraborty and M. Simoes, “Experimental evaluation of active filtering in a single-phase high-frequency ac microgrid,” IEEE Trans. on Energy Conversion, vol. 24, no. 3, pp. 673–682, Sept 2009.
- [13]. V. Khadkikar and A. Chandra, “A novel structure for three-phase fourwire distribution system utilizing unified power quality conditioner (UPQC),” IEEE Trans. on Ind. Appl., vol. 45, no. 5, pp. 1897–1902, Sept 2009.



Budharapu Haritha, PG Scholar, in Power Electronics, Sridevi Women’s Engineering College, Hyderabad, Telangana.
Email: sonabudharapu@gmail.com



Swetha Bejugam , Assistant Professor in Power Electronics and Electrical drives, Sridevi Women’s Engineering College, Hyderabad, Telangana.