

**Industrial
Rivet &
Fastener Co.**



OPERATIONS MANUAL

FOR THE PNEUMATIC - HYDRAULIC RIVETING TOOL

RK-9000M

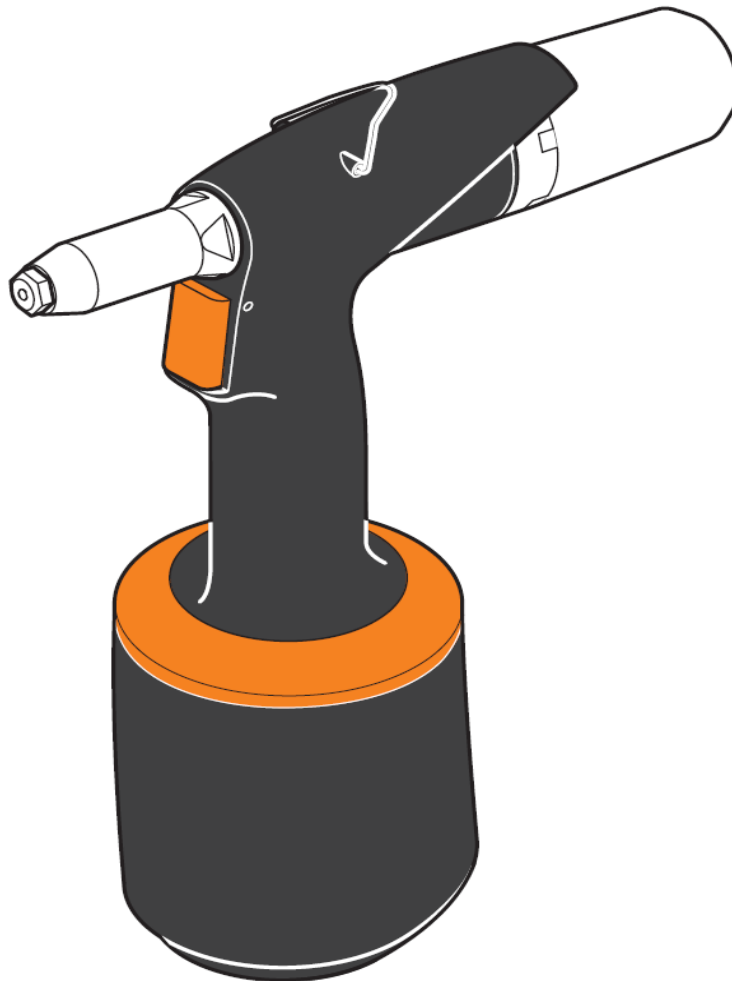



TABLE OF CONTENTS :

1. GENERAL SAFETY INSTRUCTIONS AND PRINCIPLES 	3
2. DESCRIPTION OF THE TOOL	4
2.1. Basic dimensions	4
2.2. Technical data	4
2.3. Range of usage	5
2.4. Tool operation	5
3. TOOL MAINTENANCE	7
3.1. Daily maintenance	7
3.2. Weekly maintenance	7
3.3. General maintenance	9
4. SPARE PARTS	9
4.1. Ordering	9
4.2. List of quickly expendable parts	10
5. STORAGE	10
6. COMPLETE TOOL EQUIPMENT	10
7. OPERATIONS AND WARRANTY CONDITIONS	10
7.1. Operation conditions	11
7.2. Warranty condition	11

1. GENERAL SAFETY INSTRUCTIONS AND PRINCIPLES

ATTENTION! Read all instructions and principles carefully. Every person installing, operating or maintaining the tool must be first thoroughly acquainted with this operations manual and is obliged to adhere to the following safety instructions and principles:

- The tool must not be used for other purposes than those for which it was designed.
- The tool must not be used in a different manner than that recommended by the manufacturer
- Any alterations of the tool, its accessories or spare parts remain in sole responsibility of the customer. After agreement the manufacturer provide technical support in designing and making additional alterations.
- The tool must be kept in top condition and regularly tested for damage and proper operation. The tool must be repaired only by an authorized technician or by a person trained by the manufacturer or supplier. Should you have any demand for training, please contact your sales agent.
- The tool must always be operated in accordance with respective sanitary and safety regulations.
- All queries regarding proper and safe operation of the tool should be addressed to your sales agent.
- Safety principles that must be adhered to in connection with operation of this tool must be known to all workers who operate the tool.
- When handling the tool take extra care to avoid unwanted activation and possible injury.
- The tool must be during any kind of maintenance or repair (does not apply to replacing nose-pieces and emptying the mandrel container) disconnected from the source of compressed air.
- Before operating the tool always take up firm posture and steady position.
- It is necessary to prevent break-away shanks endangering safe operation of the tool.
- Never aim with the tool at another person.
- Always check that the vent holes are not blocked or covered and that the supply hose are in good condition.
- Working pressure must not exceed 95 PSI.
- Oxygen or other flammable gasses from pressure cylinders must not serve as a driving agent.
- When operating the tool it is recommended to use safety glasses and utility gloves.
- If the continuous cycle of riveting exceeds 8 hours per day, it is recommended that the operators use ear protectors.
- When working with the tool the operator must not have loose parts of wear as e.g. a tie, long hair, jewellery etc. to avoid getting caught by the tool.
- Same safety instructions apply for persons standing close to the tool.
- Avoid unnecessary contact with the hydraulic fluid to prevent possible allergy reaction of the skin.
- The tool is not designed for outdoor and explosive environment.
- After the service life, discard the tool according to the Disposal Act no. 185/01 Coll.

2. DESCRIPTION OF THE TOOL

2.1. Basic dimensions

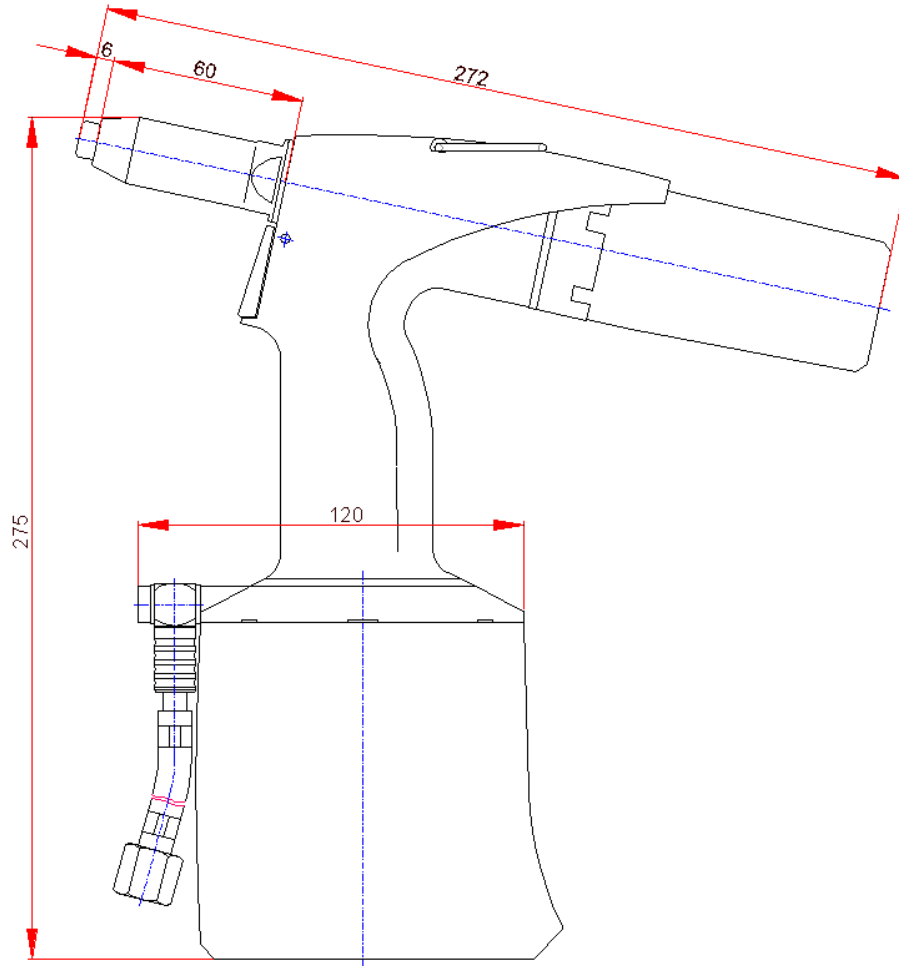

2.2. Technical data

weight.....	1,84 kg
working pressure.....	85 - 95 PSI
stroke force at 0,6 MPa.....	12,5 kN
air consumption.....	2,0 l / stroke
stroke.....	21 mm
height.....	275 mm
length.....	272 mm
width (over the aircoupling).....	120 mm

2.3. Range of usage

The pneumatic-hydraulic tool is designed for riveting with blind rivets:

Type of rivet	Al (aluminium)	St (steel)	Rv (stainless steel)	Recommended nose-pieces*
standard	Ø 4,0	Ø 4,0	Ø 4,0	nose-piece no. 4
standard	Ø 4,8 - Ø 5,0	Ø 4,8 - Ø 5,0	Ø 4,8 - Ø 5,0	nose-piece no. 5
standard	Ø 6,0	Ø 6,0	Ø 6,0	nose-piece no. 6
standard	Ø 6,4	Ø 6,4	Ø 6,4	nose-piece no. 6.4

* Recommended nose-pieces with respect to rivet diameters (does not apply for all types of rivets)

2.4. Tool operation

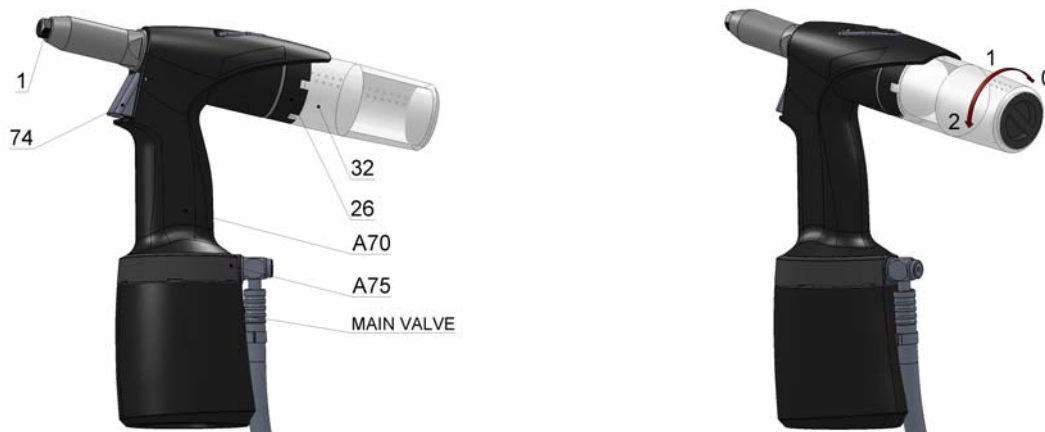

Fig. 1

The manufacturer equipped the tool with a nose-piece /fig.1 – pos.1/ for a rivet Ø 6.4. Riveting with blind rivets of different diameters (further on referred to as BR) requires use of appropriate nose-pieces that are located in the accessories casing of the tool.

Replacement of nose-pieces: Connect the tool to the source of compressed air, depress the trigger and screw out the nose-piece /fig.1 – pos.1/ with a spanner no. 12. Screw on a new nose-piece /acc. to the chart/ and tighten it. Now you can release the trigger of the tool.

The tool is equipped with revolving air supply /fig.1 – pos.A75/ which enables manipulation with air supply before as well as during tool operation, air hose does not obstruct riveting in any position.

The tool is equipped with multifunction trigger /fig.1 - pos.74/ which enables following:

- 1) Rotational movement of the trigger around the pin - riveting.
 - The trigger is on the front extreme position, not pressed.
 - Depressing the trigger shall fix the rivet.

2) Vertical movement of the trigger – switching off the suction.

- Press and lock the trigger (after pressing shift it up cca 1,5 mm), then release the trigger, the suction is switched off.
- Unlock the trigger (shifting the trigger down to the stop) and release it. The suction is switched on and the trigger is in position see fig. 1.

The tool is equipped with a multifunctional mandrel container /fig.1 – pos.32/ which has the following positions:

Position 0 – mandrel container removed

Position 1 – mandrel container mounted, suction is switched off

Position 2 – mandrel container mounted, suction is switched on

1) Mounting the mandrel container:

Put and push the mandrel container /fig. 1 - pos. 5/ into the ring relief /fig.1 – pos.6/ end-to-end, thus you depress the arrestment element, and turn to position 1 or 2. The mandrel container shall thus be in place. The suction shall initiate in position 2. Relative position of the mandrel container with air outlets /fig.1 - pos.7/ and the ring relief /fig.1 – pos.7/ ensures that the outlet air pressure goes out in a suitable direction (e.g. Off ward the operator of the tool).

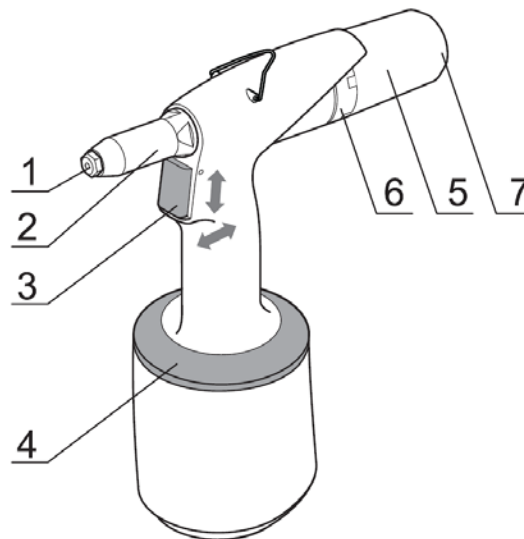

Fig. 1

2) Removing the mandrel container:

Turn the mandrel container /fig.1 - pos.32/ end-to-end to position 0 and pull it out of the ring relief /fig.1 – pos.26/. The suction shall thus switch off.

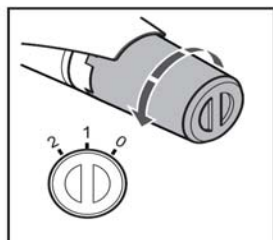

Fig. 1/1A

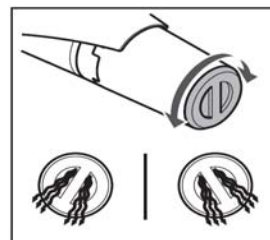

Fig. 1/1B

The tool can be operated in the following manners:

1) with the mandrel container removed in position 0:

Suction switches off by turning and removing the mandrel container /fig.1 - pos.32/. Insert BR into the riveting tool through the nose-piece hole. Depress the trigger to move the jaws offward the BR head. The movement ends when reaching max. stroke, correct BR with respect for material gauge shall tear off the shank (riveting) for one stroke of the tool. Releasing the trigger shall return the jaws to initial position and released torn-off shank can be removed from the nose-piece by tilting the tool. /fig.1 - pos.1/.

2) with the mandrel container mounted in position 1:

Mounting and turning the mandrel container /fig.1 - pos.32/ to position 1 shall arrest it. Insert BR into the riveting tool through the nose-piece hole. Depress the trigger to move the jaws offward the BR head. The movement ends when reaching max. stroke, correct BR with respect for material gauge shall tear off the shank (riveting) for one stroke of the tool. Releasing the trigger shall return the jaws to initial position and the released torn-off shank can be transported into the mandrel container by tilting the tool.

3) with the mandrel container mounted in position 2:

Suction switches on by turning the mandrel container /fig.1 - pos.32/ to position 2. In this position the suction holds BR in the nose-piece /fig.1 - pos.1/ which enables riveting in any position without danger of BR falling out of the nose-piece of the tool. Depressing the trigger shall perform riveting. Releasing the trigger shall transport the shank into the mandrel container. If the mandrel container is full with shank to appx. 70%, it is necessary to remove and empty it in a specified manner (e.g. to a prepared container). Overfill of the mandrel container may result in failure of the riveting tool.

3. TOOL MAINTENANCE

During maintenance the tool must be disconnected from the source of compressed air !!!

3.1. Daily maintenance

Before starting work, apply several drops of lubricating oil (we recommend hydraulic oil HYSPIIN AWHM 32 CASTROL) into the air inlet of the tool, on condition there is no lubricating device connected in the air distribution.

Check the tool for air leakage, if necessary replace damaged hoses and clasps.

If the pressure regulator is not equipped with a filter, blow through the air hose before its connection to the tool in order to get rid of impurities and water. If the pressure regulator has a filter, dry it out.

Check whether the fixed nose-piece corresponds to the BR diameter and that all screw threads and joints are tightened properly.

Check whether the holes for passage are really empty. If it is not so, it is necessary to remove the damaged part, clean the hole or replace the damaged part with a new one, see paragraph 3.2 weekly maintenance.

3.2. Weekly maintenance

Cleaning of the tool and replacement of worn or non-functional parts.

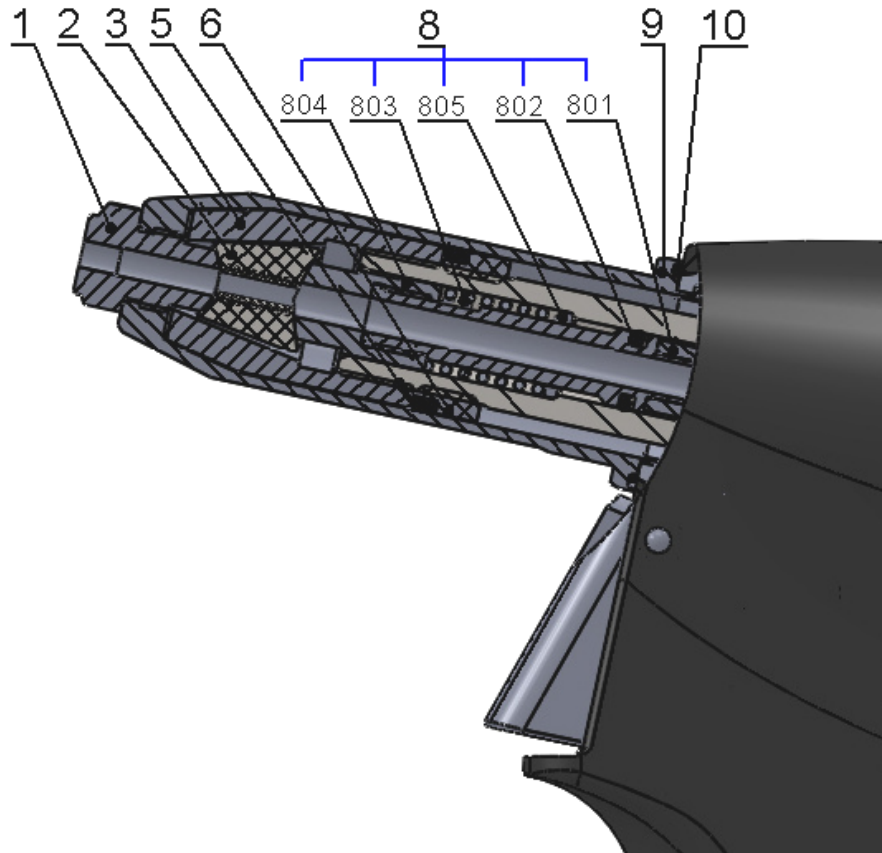

Fig. 2

Disassembly:

Disconnect the tool from the source of compressed air, unscrew the front nozzle /fig.2 - pos.9/ by means of a spanner no.23, set the spanner no.17(15) onto the clamping sleeve /fig.2 - pos.3/, set the spanner no.17 on the backnut /fig.2 - pos.6/ and loosen. Unscrew the clamping sleeve, replace the jaws /fig.2 - pos.2/ and conduit-suction complet /fig.2 - pos.8/. All used threads are clockwise. Clean the dismantled parts thoroughly and check them visually, especially the following:

- 1) Jaws /fig.2 – pos.2/ - if worn or damaged, replace it, if dirty, clean it with a wire brush.
- 2) Nose-piece /fig.2 – pos.1/ - for wear of functional surfaces of the taper.
- 3) Conduit-suction complet /fig.2 - pos.8/ - inspect parts of the assembly, jaw pusher /fig.2 - pos.804/, spring /fig.2 - pos.803/, washer of spring /fig.2 - pos.805/, O - ring /fig.2 - pos.802/ and conduit-suction /fig.2 - pos.801/ - if damaged or worn, replace it with a new one.
- 4) Front nozzle /fig.2 - pos.9/ - check for damage of the internal surface (\varnothing 20) .
- 5) Scraper ring /fig.2 - pos.5/ - if damaged or worn, replace it with a new one.
- 6) Mandrel container - if the mandrel container or its bottom are worn or damaged, replace them with new ones, otherwise there is danger of the torn-off shank popping out.

Assembly:

Mount the parts (see par. disassembly) in a reverse order. On the outer surface of the jaws /fig.2 – pos.2/ apply a drop of lubricating oil (we recommend hydraulic oil HYPIN AWHM 32 CASTROL), apply thin layer of plastic lubricant MOGUL LV 2-3 to the conduit-suction complet /fig.2 – pos.8/. Basic set-up of the jaws is performed as in fig. 3.

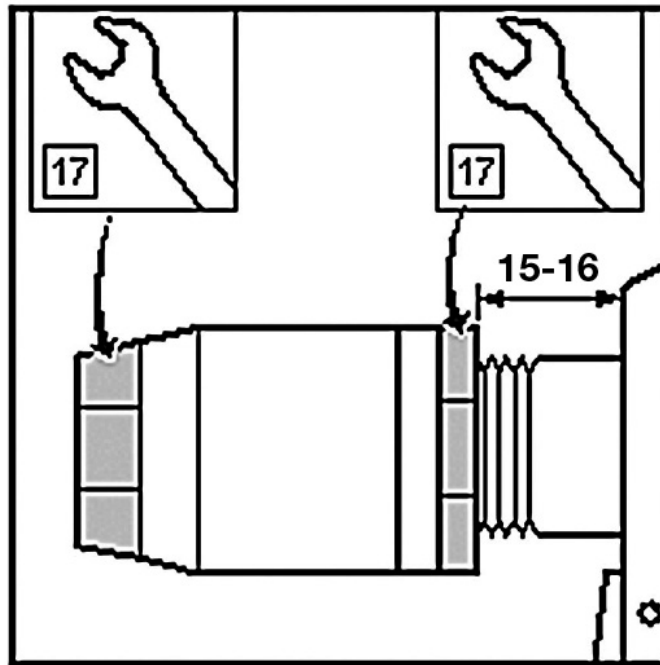

Fig. 3

3.3. General maintenance

General maintenance should be performed after about 500 000 strokes or once every three years. The tool must be completely disassembled and all seals and worn parts must be replaced. This repair may be carried out by an authorized technician only or a person trained by the manufacturer or supplier.

4. SPARE PARTS

4.1. Ordering

Order the spare parts exclusively from the manufacturer or from your sales agent.

The order must contain:

- a) tool serial number
- b) number of ordered part
- c) number of pieces
- d) name of your company and precise address
- e) your tax identification number and identification number

4.2. List of quickly expendable parts

Nose-piece 4	RK9000-BP1-3
Nose-piece 5	RK9000-BP1-4
Nose-piece 6	RK9000-BP1-5
Nose-piece 6,4	RK9000-BP1-6
Clamping sleeve	RK9000-BP3
Set of jaws	RK9000-BP2
Conduit suction	RK9000M- BP7
"O" ring 7,1/1,6	RK9000-BP8
Spring of jaw pusher	RK9000-BP9
Jaw pusher	RK9000MLS-BP10
Scraper ring	RK9000-BP4
Nut HP.....	RK9000-BP5
Mandrel container	RK9000M-BP42

5. STORAGE

The pneumatic-hydraulic tool embedded in a shipping container must be stored in environment with relative humidity to 70% and temperature ranging from +5°C to +40°C, without aggressive evaporation of salts, acids and caustics.

6. COMPLETE TOOL EQUIPMENT

Replaceable nose-pieces located in a plastic plate, Operations manual, Certificate of warranty.

7. OPERATIONS AND WARRANTY CONDITIONS

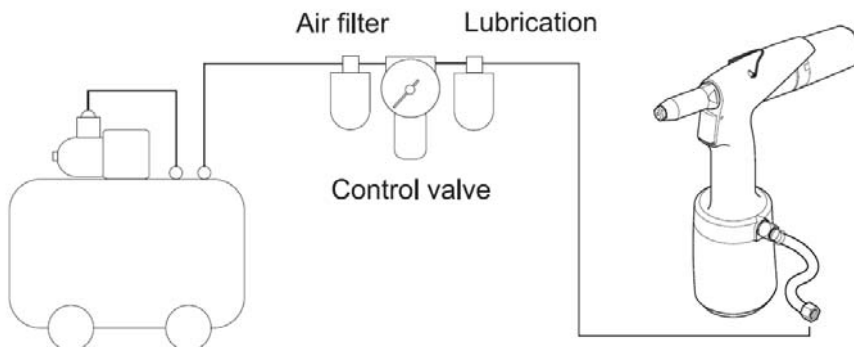

For reliable function of the tool we recommend to use treated compressed air. Treated compressed air means compressed atmospheric air bare of solid particles and water, reduced to required pressure and lubricated with anti-corrosive oil.

7.1. Operation conditions

For reliable function of the tool it is necessary to use treated compressed air. Treated compressed air means compressed atmospheric air free of solid particles and water, reduced to required pressure and lubricated with anti-corrosive oil. Immediately before the tool there must be a regulation valve set to maximum outlet pressure of 0,7 MPa, air filter and lubrication in the circuit of compressed air.

Sound-pressure level of impulse noise, $L_{pAI} = 107,7$ dB(A), peak C-weighted sound pressure, $CLC_{peak} = 114,1$ dB(C), against which during continuous and long-term operation it is recommended to use ear protectors. Average overall vibration total value $L_{avw,T} = 126,8$ dB re 10^{-6} m.s⁻², average overall vibration total effective value $a_{vw,T} = 2,188$ m.s⁻².

The trigger enables safe control of the tool with a force max. 10 N < 50 N without releasing the grip-handle according to the health regulation.

7.2. Warranty conditions

For reliable and safe function of the tool it is necessary to adhere to instructions and principles stated above.

For the warranty period the customer must not perform any alterations other than those permitted by the manufacturer, see paragraph 2. 1, 3. 1, 3. 2. Other non-detachable parts are secured with paint. In case of neglecting this protection the manufacturer shall not admit possible warranty repairs. To admit warranty repair the customer must submit confirmed warranty certificate of the tool, Certificate of quality and completeness or proof of purchase. The warranty period is 24 months from the day of purchase confirmed in the Warranty certificate if the purchase contract does not state otherwise.

Warranty is valid provided that the following:

- General safety instruction and principles (paragraph 1)
- Tool operation (paragraph 2.4)
- Daily and weekly maintenance (paragraph 3.1 and 3.2)
- Storage (paragraph 5)
- Operations and warranty conditions (paragraph 7)

Warranty does not apply to quickly expendable parts (see paragraph 4.2).