

Model 141 Exhaust Silencer

Standard Features:

- ✓ All Steel Welded Construction
- ✓ Quality Fabrication Techniques
- ✓ Shell Constructed with Integral Damping
- ✓ Prime Coated Exterior Surfaces
- ✓ Condensate Drain
- ✓ Plate Flanges Drilled to Match ASA 125# Flanges

Optional Features:

- ✓ Low, Mid, or High Side Inlet
- ✓ Materials as Specified
- ✓ Finish as Specified
- ✓ Mounting Brackets or Supports for Vertical or Horizontal Installation
- ✓ Inspection Openings or Man Ways
- ✓ Explosion Relief Covers
- ✓ Companion Flanges

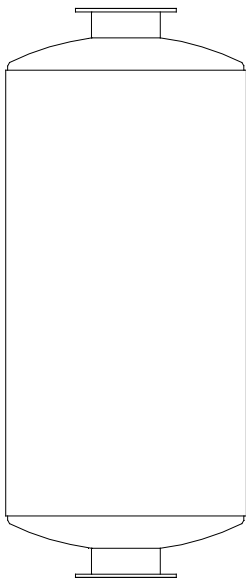
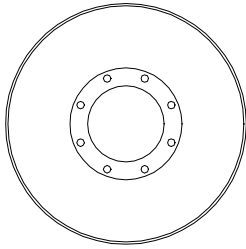

Application:

The **VANEC** Model 141 Exhaust Silencer is designed for use in suppressing the exhaust noise of any internal combustion engine, and a variety of rotary blowers and vacuum pumps.

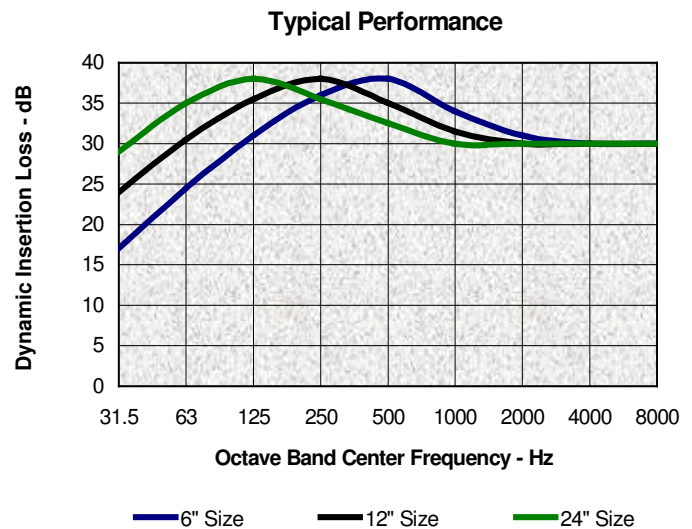

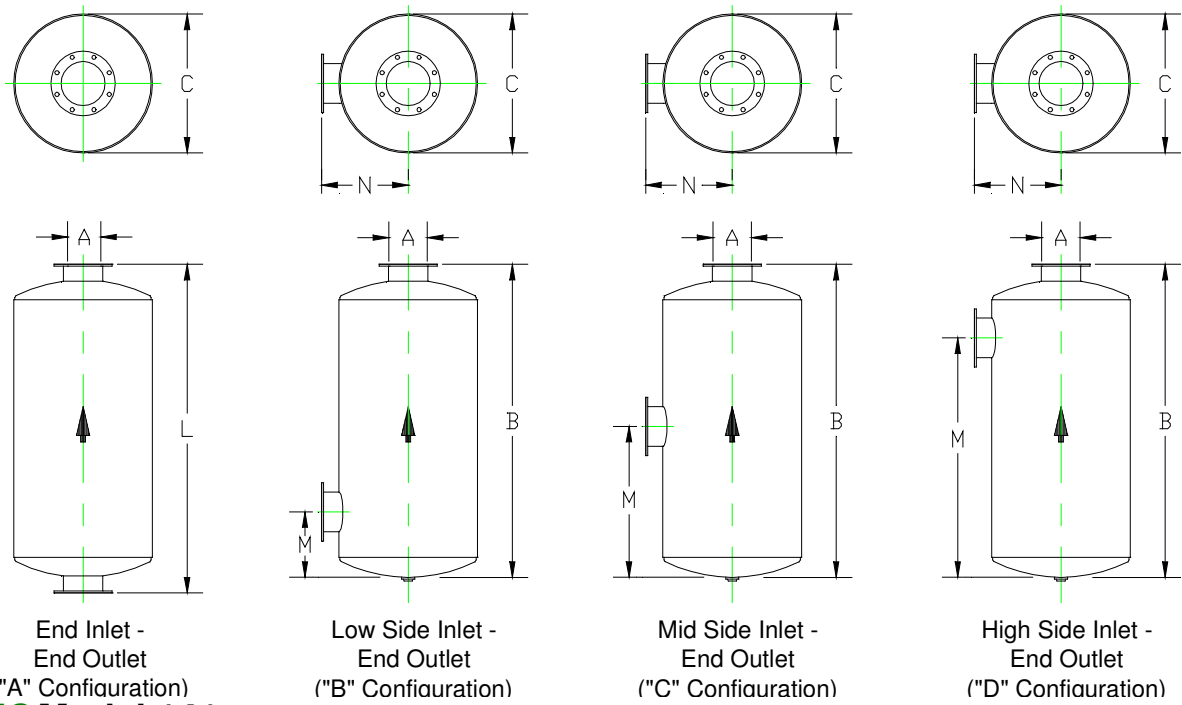

VANEC Model 141

Model	Dimensions in Inches											Est. Wt. Lbs.
	All Models		"A" Config.	Side Inlet Configuration								
	A	C	L	B	N	"B" Config. M – Low		"C" Config. M – Mid		"D" Config. M – High		
						Min	Max	Min	Max	Min	Max	
141-02.5	2½	10	46	39	8	5	-	-	-	-	-	50
141-03	3	12	48	44	10	6	-	-	-	-	-	75
141-03.5	3½	14	54	50	11	6	18	-	-	-	-	100
141-04	4	14	71	68	11	9	24	26	38	41	55	120
141-05	5	16	77	74	12	9	25	28	43	46	61	160
141-06	6	18	96	93	13	12	38	42	62	66	80	310
141-08	8	26	110	107	17	13	38	43	67	72	90	560
141-10	10	30	127	122	20	14	42	50	78	82	102	870
141-12	12	36	150	146	22	19	52	60	90	96	125	1400
141-14	14	36	199	196	22	20	54	62	110	115	171	1720
141-16	16	42	213	210	25	22	60	64	120	124	183	2130
141-18	18	48	215	211	28	23	61	65	121	125	183	3090
141-20	20	54	229	226	31	26	70	74	130	134	194	3900
141-22	22	54	237	233	32	27	72	76	134	140	199	3970
141-24	24	60	268	264	35	29	90	96	144	167	229	6260

Units smaller than 4" are supplied with threaded nozzles.

VANEC Industrial Silencers
716-827-4959