

# SERIES 631 SPECIFICATIONS

## Individual, Omni-Directional Panels

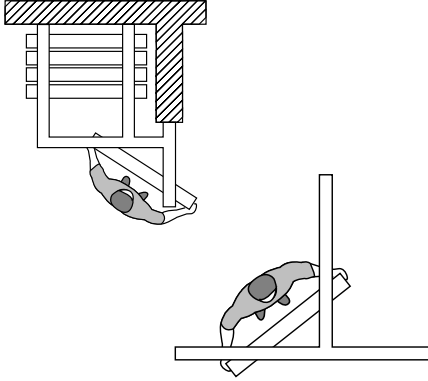

**Top Supported  
Side Stack  
Individual, Omni-Directional Panels  
Manually Operated**  
**Maximum Opening Height:** 24'3" [7391]  
**Maximum Opening Width:** Unlimited  
**STC Ratings:** 41, 43, 47, 49, 51

### PRODUCT OVERVIEW:

**Select for Value:** Series 631 panels offer a wide choice of finish options, accessories, and sound control levels.

**Standard Features:** The panels are nominally 3" [76] thick, and have a frame of 16 ga. steel. The top horizontal sound seal is of multi-finger vinyl, and the bottom sound seal is retractable and provides up to 2" [50] floor clearance (to accommodate out-of-level floors). The faces may be covered from a wide selection of vinyl colors and patterns. The face substrate varies by the level of sound control required (STC rating).

**Individual, Omni-Directional Panels:** Individual, manually operated panels offer optimum room flexibility. The track system enables panels to negotiate turns and be used in alternate locations.

**How to Obtain:** Hufcor partitions are sold, installed, and serviced by factory-trained local authorized Distributors in the United States and by Licensees and Distributors outside the U.S.A.

**Delivery:** Panels are custom built for your specific project. Lead times vary due to seasonal fluctuations. Check with your Distributor for the current schedule.

**Warranty:** Track and panels are guaranteed for **two years** against defects in material and workmanship.

### "Standard" Product Features and Benefits:

Look for these features when comparing similar products.

- Feature:** Protective vertical trim (Available option: no protective vertical face trim.)  
**Benefit:** Trim protects the panel edges and faces plus it provides a handhold when moving panels.
- Feature:** Quick-Set™ Retractable Seals  
**Benefit:** The retractable seals are Quick-Set™ which means they are easily extended or retracted with only a 1/2 turn of the removable handle. No tedious cranking needed to set the seals.
- Feature:** 2" [50] retractable bottom seals  
**Benefit:** Retractable seals accommodate out-of-level floor conditions. When retracted, nothing drags on the floor when the panels are moved. Panels can be "locked" in place.
- Feature:** Retractable bottom seals exert downward seal force  
**Benefit:** Provides constant force against floor for optimum acoustics even on carpet or other porous floor materials. Maintains panel stability when the seals are set.
- Feature:** Waist high seal activator for quick set retractable seals.  
**Benefit:** Fast, easy seal activation without bending or stooping.
- Feature:** Removable operating handle.  
**Benefit:** Prevents unauthorized operation.
- Feature:** Expanding Jamb Closure (Lever Closure) Panel  
**Benefit:** Exerts 250 lbs [113.4 kg] of force against the fixed wall. The compression creates tight panel joints for optimum sound control.
- Feature:** Interlocking vertical seals  
**Benefit:** Ensures panel-to-panel alignment and prevents sound leaks between panels.

Optional track systems, seals, and accessories enable the standard product to be modified for optimum versatility. See details provided or ask your Hufcor representative for the features you want.



# GENERAL SPECIFICATIONS/SERIES 631

## Individual, Omni-Directional Operable Partitions

### PART 1 - GENERAL

#### 1.01 DESCRIPTION

##### A. General

1. Furnish and install operable partitions and suspension system.  
Provide all labor, materials, tools, equipment, and services for operable walls in accordance with provisions of contract documents.

#### 1.02 RELATED WORK BY OTHERS

- A. Preparation of opening will be by General Contractor. Any deviation of site conditions contrary to approved shop drawings must be called to the attention of the architect.
- B. All header, blocking, support structures, jambs, track enclosures, surrounding insulation, and sound baffles as required in 1.04 Quality Assurance.
- C. Prepunching of support structure in accordance with approved shop drawings.
- D. Paint or otherwise finishing all trim and other materials adjoining head and jamb of operable partitions.

#### 1.03 SUBMITTALS

- A. Complete shop drawings are to be provided prior to fabrication indicating construction and installation details. Shop drawings must be submitted within 60 days after receipt of signed contract.

#### 1.04 QUALITY ASSURANCE

- A. Preparation of the opening shall conform to the criteria set forth per ASTM E557 Standard Practice for Architectural Application and Installation of Operable Partitions
- B. The partition STC (Sound Transmission Classification) shall be achieved per the standard test methods ASTM E90.
- C. Noise isolation classifications shall be achieved per the standard test methods ASTM E336 and ASTM E413.
- D. Noise Reduction Coefficient (NRC) ratings shall be per ASTM C423.
- E. Rack testing for 10 years. (tensional strength stress test)
- F. The manufacturer shall have a quality system that is registered to the ISO 9001 standards.

#### 1.05 PRODUCT DELIVERY, STORAGE, AND HANDLING

- A. Proper storage of partitions before installation and continued protection during and after installation will be the responsibility of the General Contractor.

#### 1.06 WARRANTY

- A. Partition system shall be guaranteed for a period of two years against defects in material and workmanship, excluding abuse.

### PART 2 - PRODUCTS

#### 2.01 ACCEPTABLE MANUFACTURERS

- A. Upon compliance with all of the criteria specified in this section, Manufacturers wishing to bid products equal to the product specified must submit to the architect 10 days prior to bidding complete data in support of compliance and a list of three past installations of products similar to those listed. The submitting manufacturer guarantees the proposed substituted product complies with the performance items specified and as detailed on the drawings.

#### 2.02 MATERIALS

- A. Product to be top supported Series 631 individual, omni-directional panels as manufactured by Hufcor Inc.
  1. Panels shall be nominally 3" [76] thick and to 48" [1219] in width.
  2. Panel faces shall be laminated to appropriate substrate to meet the STC requirement in 2.04 Acoustical Performance.
    - a. Optional substrate material (Not all substrates are available for all STC ratings. Consult your Hufcor Distributor for more information):
      - Steel
      - Non-steel
      - Medium Density Fiberboard
    - b. Horizontal Splice: Heights over 16'3" [4953] with non-steel faces require a structural splice placed at approximately 12'3" [3734] from the floor.
  3. Frames shall be of 16 gauge [1.42mm] painted steel with integral factory applied aluminum vertical edge and face protection.

Optional: Face finish shall wrap around the vertical panel edges and provide no protective vertical face trim.

4. Vertical sound seals shall be of tongue and groove configuration, ensure panel-to-panel alignment and prevent sound leaks between panels.
  5. Horizontal top seals shall be fixed continuous contact dual 4-finger vinyl. (Option: Horizontal top seals shall be retractable, provide 1" [25] nominal operating clearance, and exert upward force when extended. All panels, including pass door panels and lever closure panels must have retractable top and bottom seals. Not available with automatic bottom seals.)
  6. Horizontal bottom seals shall be retractable, provide up to 2" [50] nominal operating clearance, and exert downward force when extended.  
Optional Seals:
    - (a) Horizontal bottom seals shall be automatic and provide up to 2" [50] nominal operating clearance. Consult your Hufcor Distributor for more information.)
    - (b) Horizontal bottom seals shall be fixed continuous contact dual 4-finger vinyl.
  7. Horizontal trim shall be of aluminum.
- B. Weight of the panels shall be 5.7-10.2 lbs. per sq. ft. [27.8-49.8kg/sq.m] based on options selected.
- C. Suspension system:
1. Track shall be of clear anodized architectural grade extruded aluminum alloy 6063-T6. Track design shall provide precise alignment at the trolley running surfaces and provide integral support for adjoining ceiling, soffit, or plenum sound barrier. Track shall be connected to the structural support by pairs of minimum 3/8" [10] dia. threaded steel hanger rods. Pairs of rods are directly attached to the track, no single point attachment allowed. L, T, or X intersections shall be factory assembled and welded.
    - a. Each panel shall be supported by two 2-wheeled counter-rotating horizontal carriers. Wheels to be of precision ground steel ball bearings with heat treated and hardened races encased with molded polymer tires.
      - (1) Optional Type 38 (for X, L, or T intersections and panels weighing up to 400 lbs. [182 kg]): Each panel shall be supported by two 1-wheel horizontal rotating carriers. Wheel to be of precision ground steel ball bearings with heat treated and hardened races encased with molded polymer tires.
      - (2) Optional Type 38 (for curves and diverts and panels weighing up to 600 lbs. [272 kg]): Each panel shall be supported by two 4-wheel carriers.
    2. Plenum closure (by others): Design of plenum closure must permit lifting out of header panels to adjust track height. Plenum closure required for optimum sound control of partition.
    3. Option (available for select layouts-consult your Hufcor Distributor): The panels shall be supported by the Unispan pre-engineered truss and post system fabricated of steel and aluminum. Unispan is attached to the building structure for lateral support only. The load of the truss and partition is supported by end columns. The columns are connected to floor plates that distribute the load of the system at the floor.
- D. Finishes
1. Face finish shall be: **(select as required)**:
    - a. Factory applied reinforced vinyl fabric with woven backing, weighing not less than 15 oz. per lineal yard [465 g/m]. Color shall be selected from manufacturer's standard color selectors.
    - b. Standard upgrade fabrics (color shall be selected from manufacturer's standard color selector):
      - (1) Factory applied vertical ribbed carpet (N.R.C. .20)
      - (2) Factory applied stain resistant fabric
  - c. Optional:
    - (1) Customer selected (requires factory approval for manufacturing compatibility)
    - (2) Unfinished for field decoration
    - (3) Wood veneer (factory installed on trimmed models)
    - (4) High pressure laminate (factory installed on trimmed models)
    - (5) Murals. Choose from Mural Imagery stock photos or create your own custom design.
  2. Exposed metal trim and seal color shall be **(select from Hufcor's Standard Trim selector)**:
    - a. Lamb's Wool (standard)
    - b. Brown (standard)
    - c. Gray (standard)
    - d. Custom powder coated (optional upgrade for metal trim)



- 3. Aluminum track shall be clear anodized
  - a. Optional upgrade:
    - (1) Custom anodized
    - (2) Custom powder coated
- E. Available Accessories/Options
  - 1. ADA compliant pass door of the same thickness and construction as the basic panels. Pass door panel legs require bottom seals that provide downward force to maintain stability during door operation. Pass door leaf has perimeter trim to protect face finish and to provide visual identification as required by International Building Code. Pass door leaf incorporates a self-adjusting retractable bottom seal providing sound control when door is closed.
    - a. Automatic door closer
    - b. Door lock
    - c. Exit sign (consult your local code)
    - d. Prepped for window
    - e. Peep hole
  - 2. Inset chalk/writing/projection surfaces
  - 3. Inset tackboards
  - 4. Inset eraser pocket
  - 5. Segmented faces
  - 6. Finished end cover
  - 7. Pocket doors
  - 8. Inset chair rail pan (for field installation of chair rail).
  - 9. Custom design options (consult your local Hufcor Distributor)

2.03 OPERATION

- A. Panels are manually moved from the storage area, positioned in the opening, and seals set.
- B. Retractable Horizontal Seals
  - 1. Retractable horizontal seals shall be activated by a removable quick-set operating handle located approximately 42" [1067] from the floor in the panel edge. Seal activation requires approximately 15 lbs. [6.8 kg] of force per panel and approximately a 190 degree turn of the removable handle. Top and bottom retractable seals on each panel shall be operated simultaneously.
- C. Automatic Floor Seals
  - 1. Horizontal seals shall be activated by pressing the edge of the panel into the edge of the adjacent panel or wall.
  - 2. Seal activation requires approximately 15 lbs. [6.8 kg] of force per panel.

- D. Final partition closure to be by (select one):
  - 1. Lever closure panel with expanding jamb which compensates for minor wall irregularities and provides a minimum of 250 lbs. [113.4 kg] seal force against the adjacent wall for optimum sound control. The jamb activator shall be located approximately 45" [1143] from the floor in the panel face and be accessed from either side of the panel. The jamb is equipped with a mechanical rack and pinion gear drive mechanism and shall extend 4"-6" [100-152] by turning the removable operating handle.
  - 2. Pivot Panel (Optional for heights to 12'3" [3734] and a maximum of 10 panels): Pivot panel is attached to the wall and permits access between adjacent rooms. Pivot panel is of the same construction as basic panels but with continuous contact multi-ply vinyl top and bottom seals. The lead end of the panel has full height finger pull and vertical seal of multi-ply vinyl.

2.04 ACOUSTICAL PERFORMANCE

- A. Acoustical performance shall be tested at a laboratory accredited by the National Voluntary Laboratory Accreditation Program (NVLAP) and in accordance with ASTM E90 Test Standards. Standard panel construction shall have obtained an STC rating of \_\_\_\_ (select as required): 41, 43, 47, 49, 51  
(Not all substrates are available in all STC ratings)
- 1. Complete, unaltered written test report is to be made available upon request.

PART 3 - EXECUTION

- A. Installation. The complete installation of the operable wall system shall be by an authorized factory-trained installer and be in strict accordance with the approved shop drawings and manufacturer's standard printed specifications, instructions, and recommendations.
- B. Cleaning
  - 1. All track and panel surfaces shall be wiped clean and free of handprints, grease, and soil.
  - 2. Cartoning and other installation debris shall be removed to onsite waste collection area, provided by others.
- C. Training
  - 1. Installer shall demonstrate proper operation and maintenance procedures to owner's representative.
  - 2. Operating handle and owners manuals shall be provided to owner's representative.

Header shown for plenum sound enclosure is one of several that may be used. See ASTM E557 Standard Practice for Archi Application & Installation of Operable Partitions for other recommendations.

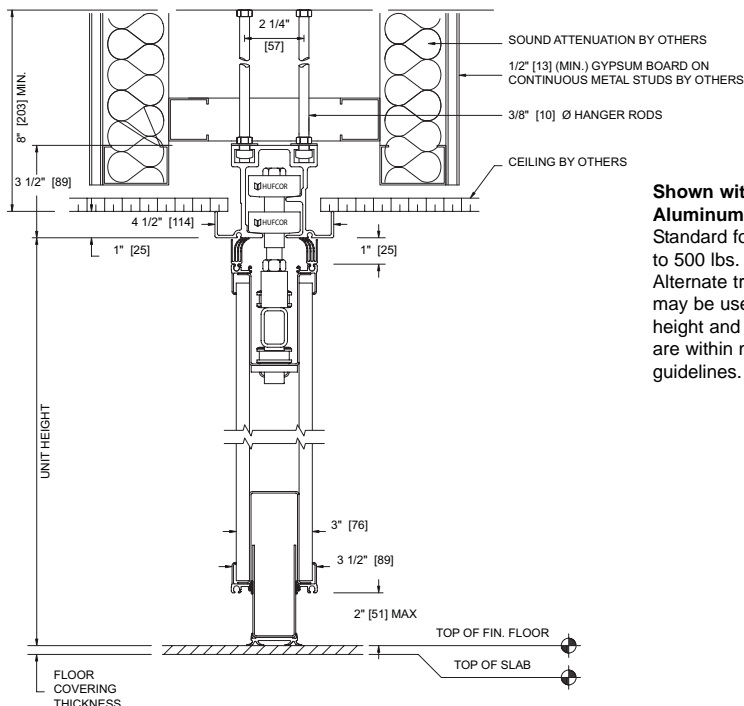

**Shown with Type 26 Aluminum track.**  
Standard for panel weights to 500 lbs. [227 kg]. Alternate track systems may be used providing the height and weight limits are within manufacturer's guidelines.



VERTICAL SECTION

No Scale

**HORIZONTAL SECTION**

Final partition closure using **Lever Closure** with expanding jamb. Solid blocking required at both ends to withstand 250 lbs. [113.4 kg] of lateral force.

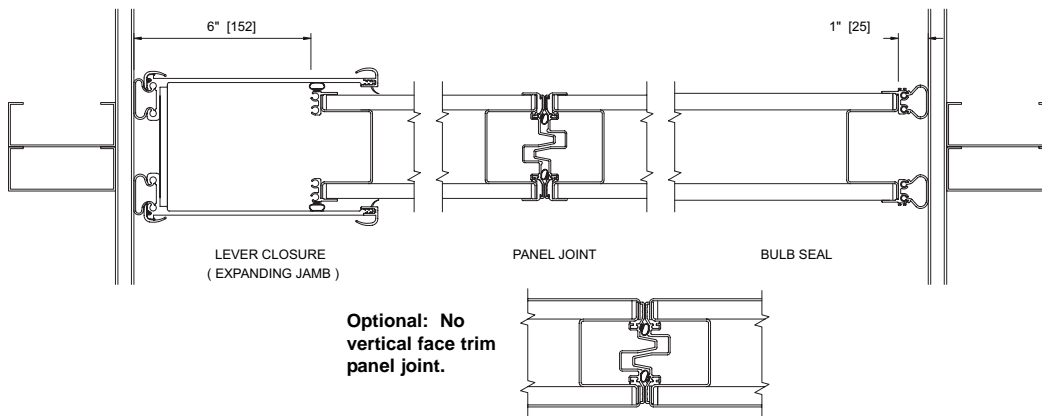

**OPTIONAL CLOSURES**

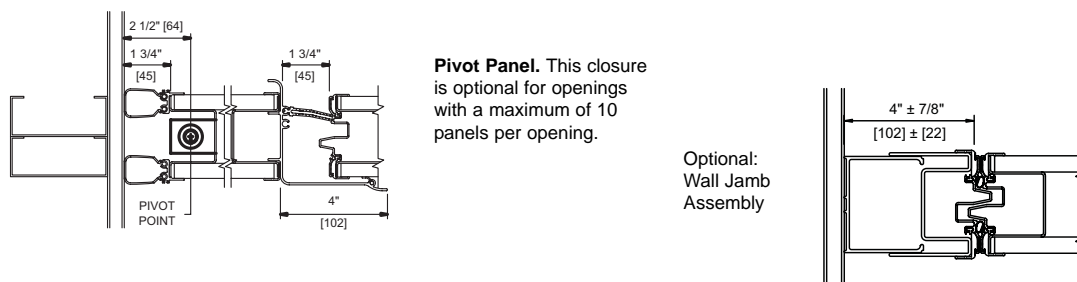

**OPTIONS & ACCESSORIES**

**ELEVATION**

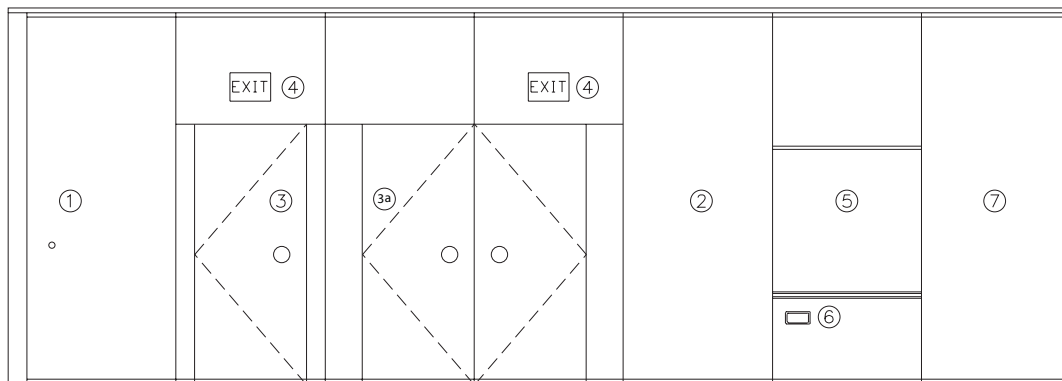

1. **Expanding Jamb Closure (Lever Closure) Panel.** Expanding jamb exerts 250 lbs. [113.4kg] force against adjacent wall for optimum sound control.
2. **Basic panel**
3. **ADA compliant pass doors** - Single 3/0 x 7/0 [914 x 2132] or 3/0 x 6/8 [914 x 2030]. Of the same construction, thickness, and finish as the basic panels. Push/pull latching handle. Options include key lock, windows, and automatic door closer. 3a. Double doors (batwings) also available.
4. **Exit Sign** - Recessed or surface mounted, self-illuminated.
5. **Work Surfaces** 4'0" [1219] high x panel width, recessed, mounted approx. 30" [762] above the floor:
  - a. Markerboard and projection/writing surfaces (from Hufcor standard color selector).
  - b. Tackboards of 2mm cork board covered with vinyl (from Hufcor standard color selector).
  - c. Marker/chalk tray (standard on chalk and projection/writing boards).
6. **Recessed Eraser Pocket** (8" x 2" x 1-1/4" deep [203 x 50 x 31]).
7. **Lead panel** with bulb seal to prevent sound leaks at adjacent wall. Optional: Lead panel closure to 4" adjustable, full height, acoustic wall jamb assembly.



## Individual, Omni-Directional Operable Partitions

### Stack Dimensions using Lever Closure Panel

Stack depth and width dimensions are based on a flat stack and standard construction with vinyl faces. Optional construction and/or face covering may increase stack depth dimensions. Angled stacks require additional space. Contact your Hufcor Distributor for angled stack requirements. (Contact the factory for pivot panel closure stack information.)

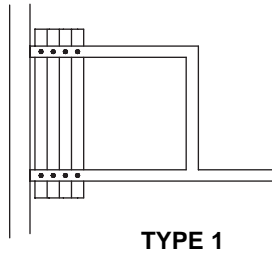

Stack Depth: 3-3/4 [95] per panel plus 1" [25]

Optional panic hardware will add to the depth of the stack. Please contact your Hufcor distributor for assistance.

Stack Width:

Retractable & sweep seal models: Panel width + 12" [300] clearance.

Automatic bottom seals: Panel width + 14" [356] clearance

For Pocket Storage: Due to the wide variety of stack configurations possible, consult your Hufcor representative for space requirements.

The Type 1 stack shown above is the most often used for simple omni-directional layouts. Following are additional common stack configurations. Stacks are not limited to these configurations and may be built to fit each job requirement. Consult your Hufcor representative for design assistance.

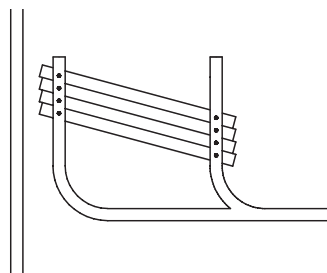
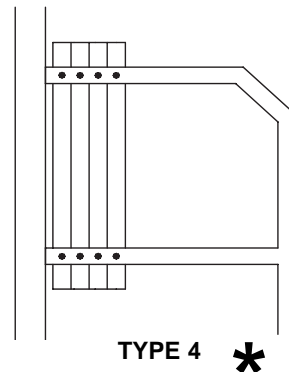
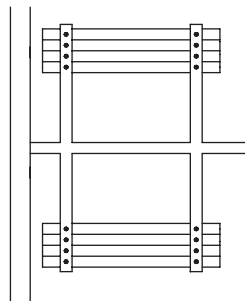
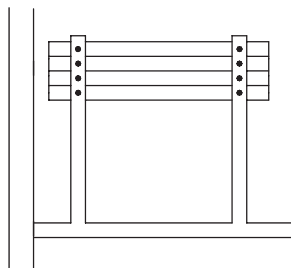

#### CAUTION

Body space is needed to access the panels and move them into position. Be certain to consult your Hufcor representative before constructing walls in pocket/stack areas. This is important for all configurations, but can be especially important for those stacks marked with an asterisk.

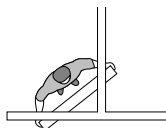

Hanging Weight		
STC	Lbs./Sq. Ft.	Kg./Sq. M
41	5.7	27.8
43	7.3	35.6
47	7.8	38.1
49	8.9	43.5
51	10.2	49.8

Optional retractable top seal (not available with automatic bottom seal)

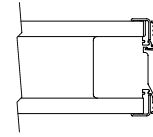
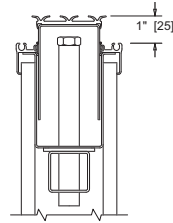

Optional finished end cover - provides finished panel end when partition run does not extend from wall-to-wall.

Optional continuous contact bottom seal.

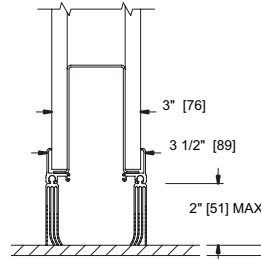

**OPTIONAL TRACKS** - Alternate Hufcor track systems may be used providing the height and weight limits are within manufacturer's guidelines.

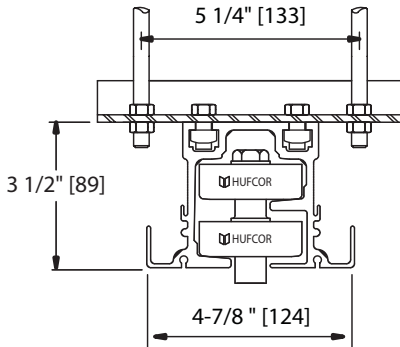

**Type 36 Aluminum Track**

Shown with optional suspension bracket for 5-1/4" [133] rod spacing. Available for all aluminum tracks.

Required for panel weights over 1000 lbs. [453 kg]. Each panel shall be supported by two carriers. Each carrier has two horizontal counter-rotating wheels that roll in the track. Each wheel has precision ground bearings encased with Delrin for quiet operation.

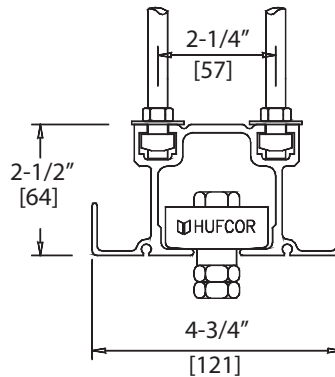

**Type 38 Aluminum Track Used in T, X, L Intersections**

Optional for panel weights to 400 lbs. [182 kg]. Each panel shall be supported by two 1-wheel horizontal rotating carriers. Wheel to be of precision ground steel ball bearings with heat treated and hardened races encased with molded polymer tires.

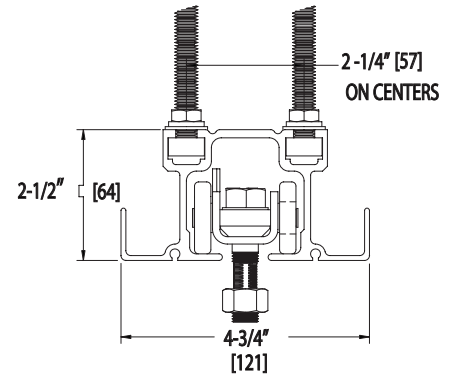

**Type 38 Aluminum Track Used for Curves/Diverts**

Optional for panel weights to 600 lbs. [272 kg]. Each panel shall be supported by two 4-wheel carriers. Wheels to be of hardened steel ball bearings encased with molded polymer tires.

**Worldwide headquarters:**

Hufcor Inc.  
 P.O. Box 591  
 2101 Kennedy Rd.  
 Janesville, WI USA 53547-0591  
 1-800-542-2371 ext. 214; 1-608-756-1241  
 FAX: 1-608-758-8253  
 E-mail: info@hufcor.com  
 Website: www.hufcor.com

The manufacturer reserves the right to improve and change product without notice.