

**BOLIN**  
TECHNOLOGY

**EX-Ultra 248F & 420F Outdoor PTZ Camera**

**User Guide**



---

## Table of Contents

Important Information  
What's In The Box  
Optional Accessories  
Recommended Peripherals  
Overview  
Features  
Camera Diagrams & Dimensions  
Quick Start Guide  
    Power  
    Network  
    Video Output  
    Control Input  
    Audio Input  
    Genlock  
    Tally Light  
Web Interface Configuration  
Updating the Firmware  
Using the Wiper  
System Menus  
Technical Specifications

---

## Important Information

Thank you for purchasing our product. If there are any questions, please contact the authorized dealer. Before operating the unit, please read this manual thoroughly and retain it for future reference.

### Copyright

Copyright 2015-2023 Bolin Technology, all rights reserved. No part of this manual may be copied, reproduced, translated, or distributed in any form or by any means without prior consent in writing from our company.

### Trademark Acknowledgment

Bolin Technology's trademarks and logos are the property of Bolin Technology. Other trademarks, company names and product names contained in this manual are the property of their respective owners.

### Trademarks and Registered Trademark Acknowledgement

- Microsoft, Windows, ActiveX, and Internet Explorer are registered trademarks of Microsoft Corporation in the U.S. and/or other countries.
- HDMI, the HDMI logo and High-Definition Multimedia Interface are trademarks or registered trademarks of HDMI Licensing, LLC in the United States and other countries.
- The Software may contain h.264/AVC video technology, the use of which requires the following notice from MPEG-LA, L.L.C.:

THIS SOFTWARE IS LICENSED UNDER THE AVC PATENT PORTFOLIO LICENSE FOR THE PERSONAL AND NON-COMMERCIAL USE OF A CONSUMER TO (I) ENCODE VIDEO IN COMPLIANCE WITH THE AVC STANDARD ("AVC VIDEO") AND/OR (II) DECODE AVC VIDEO THAT WAS ENCODED BY A CONSUMER ENGAGED IN A PERSONAL AND NON-COMMERCIAL ACTIVITY AND/OR WAS OBTAINED FROM A VIDEO PROVIDER LICENSED TO PROVIDE AVC VIDEO. NO LICENSE IS GRANTED OR SHALL BE IMPLIED FOR ANY OTHER USE. ADDITIONAL INFORMATION MAY BE OBTAINED FROM MPEG LA, L.L.C. SEE <http://www.mpegla.com>

- HEVC/H.265 Covered by one or more claims of patents listed at [patentlist.hevcadvance.com](http://patentlist.hevcadvance.com)
- HDBaseT is a trademark of the HDBaseT Alliance.
- ONVIF trademarks and logos are to be used per the guidelines established in this and other ONVIF policies and documents, including the ONVIF Rules of Membership and the ONVIF Logo Guidelines<sup>1</sup>.
- Other trademarks, company names and product names contained in this manual are the property of their respective owners.

---

## Legal Notice

Attention:

To ensure account security, the user should change the password after their first login. The user is recommended to set a strong password (no less than eight characters). Password login does not apply to certain models that do not need password login.

The contents of this document are subject to change without prior notice. Updates will be added to the new version of this manual. Improvements or updates to the products or procedures described in the manual will be made readily.



The best effort has been made to verify the integrity and correctness of the contents in this document, but no statement, information, or recommendation in this manual shall constitute a formal guarantee of any kind, expressed or implied. Responsibility for any technical or typographical errors in this manual will not be held.

The product appearance shown in this manual is for reference only and may be different from the actual appearance of the user's device.

This manual is a guide for multiple product models and so it is not intended for any specific product. In this manual, the illustrations of the displayed interface, parameters displayed, drawings, and value ranges may vary with models. The user should refer to the actual product for details. Due to uncertainties such as the physical environment, discrepancies may exist between the actual values and reference values provided in this manual.

Use of this document and the subsequent results shall be entirely on the user's own responsibility. Before operating the unit, the user should read this manual thoroughly and retain it for future reference.

### Symbols

| Symbol  | Description   |
|---|---|
|  | <b>WARNING</b><br>Contains important safety instructions and indicates situations that may cause bodily injury. |
|  | <b>CAUTION</b><br>Users must be careful. Improper operations may cause damage or malfunction of product.        |
|  | <b>NOTE</b><br>Indicates useful or supplemental information about the use of the product.                       |

### Safety Information



#### **WARNING:**

Installation and removal of the unit and its accessories must be carried out by qualified personnel. You must read all of the Safety Instructions supplied with your equipment before installation and operation.

- If the product does not work properly, please contact your dealer. Never attempt to disassemble the camera yourself. (We will not assume any responsibility for problems caused by unauthorized repair or maintenance.)
- This installation should be made by a qualified service person and should conform to all the local codes.
- When shipping, the camera should be packed in its original packaging.
- Make sure the power supply voltage is correct before using the camera.
- Do not drop the camera or subject it to physical shock.
- Do not touch sensor modules with fingers. If cleaning is necessary, use a clean cloth with a bit of ethanol and wipe it gently. If the camera will not be used for an extended period of time, put on the lens cap to protect the sensor from dirt.
- Do not aim the camera lens at the strong light such as sun or incandescent lamp. The strong light can cause fatal damage to the camera.

#### **Maintenance Precautions:**

- If there is dust on the front glass surface, remove the dust gently using an oil-free brush or a rubber dust blowing ball.
- If there is grease or a dust stain on the front glass surface, clean the glass surface gently from the center outward using anti-static gloves or an oil-free cloth. If the grease or the stain still cannot be removed, use anti-static gloves or an oil-free cloth dipped with detergent and clean the glass surface gently until it is removed.
- Do not use organic solvents, such as benzene or ethanol, when cleaning the front glass surface.

### Regulatory Compliance

#### **FCC Part 15**

This equipment has been tested and found to comply with the limits for digital devices, pursuant to part 15 of the FCC Rules. These limits are designed to provide reasonable protection against harmful interference when the equipment is operated in a commercial environment. This equipment generates, uses, and can radiate radio frequency energy and, if not installed and used in accordance with the instruction manual, may cause harmful interference to radio communications. Operation of this equipment in a residential area is likely to cause harmful interference, in which case the user will be required to correct the interference at his own expense.

This product complies with Part 15 of the FCC Rules. Operation is subject to the following two conditions: This device may not cause harmful interference.

This device must accept any interference received, including interference that may cause undesired

operation.



**LVD/EMC Directive**

This product complies with the European Low Voltage Directive 2006/95/EC and EMC Directive 2004/108/EC.



**WEEE Directive–2002/96/EC**

The product this manual refers to is covered by the Waste Electrical & Electronic Equipment (WEEE) Directive and must be disposed of in a responsible manner.

## What's In the Box



EX-Ultra Outdoor PTZ Camera



Removable Tally Light



EXU Power Supply (P36-4)



IR Remote Controller (VCC-RC-2)









RS422/232 RJ45 Adapter (VCC-CC45RS)



Protective Dust Cover



Safety Cable

|   |                                       |
|---|---------------------------------------|
|    | <p>HDMI Cable Support with Screws</p> |
|    | <p>12V Output Cable</p>               |
|    | <p>Waterproof Cover</p>               |
|    | <p>Various sized Rubber Grommets</p>  |
|  | <p>Flexible Conduit Sleeve</p>        |
|  | <p>Water Resistant Cover</p>          |

## Optional Accessories

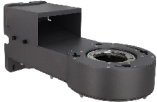
|   |  |
|---|--|
|  | <p>ES Outdoor PTZ Wall Mount Bracket (ES-WM)</p> |
|---|--|

|  |  |
|--|--|
|  | <p>10-Pin LEMO to Balanced XLR Connector (BLA-10)</p>              |
|  | <p>PTZ Drop Ceiling Pendant Mount System (C-PMSB)</p>              |
|  | <p>Large PTZ Wall Mount Bracket (C-WM3B)<br/>Cover (C-WM3B-CV)</p> |
|  | <p>PTZ Camera Vibration Isolation Kit (VAP-10)</p>                 |
|  | <p>Outdoor PTZ Mounting Base (QR-BM)</p>                           |

## Recommended Peripherals

|  |   |
|--|---|
|  | <p>97W POE Injector (BL-PP97)</p>                                   |
|  | <p>Fast HEVC IP Decoder (EG40F)<br/>Dante AV-H Decoder (EG40DH)</p> |





PTZ Controller (KBD-1010-RNV)

---

## Overview

This user guide will provide users of the EX-Ultra-248F and EX-Ultra-420F indoor PTZ cameras with in-depth knowledge of the various features and functions of the camera and how it can be utilized. Functions limited to a specific camera model will be noted as such in the various sections.

---

## Features

- Two high quality image options to choose from - FHD with 48X Zoom (EXU248F) and 1" Image Sensor, 4K60 with 20X Zoom (EXU420F)
- IP67 Waterproof Rating
- Super Image Stabilizer
- -40°C to +60°C operating temperatures
- True Tri-Output; Simultaneous and independent outputs via HDMI, SDI, and IP Stream
- Broadcast-standard SDI outputs
- Fast HEVC - Low Latency and Low Bandwidth video over IP while still maintaining high resolution
- Smooth, accurate, and PTZ motors
- Support for multiple PTZ control protocols and methods
- Firmware Upgrades via IP (Web Interface)
- Removable Tally Light
- Built-In Handle - Industry First
- On-Screen Character Generator
- Mic & Line-Level Balanced Audio Input via XLR
- Genlock Supported
- Output up to 36W power
- Built-in hidden wiper and lens hood
- Support for FreeD
- Nitrogen-filled cavity to avoid condensation build-up

## Camera Diagrams and Dimensions

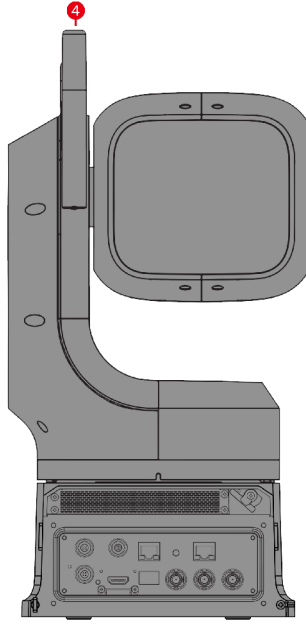
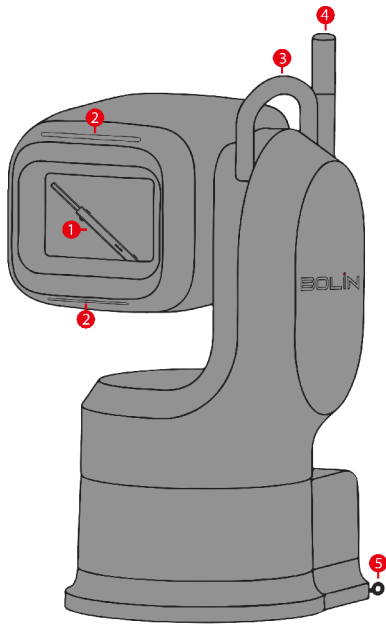

- 1 Wiper
- 2 Liquid Drainage Slots
- 3 Handle
- 4 Tally Light
- 5 Safety Loop
- 6 Mounting Holes
- 7 1/4" Tripod Mount Hole

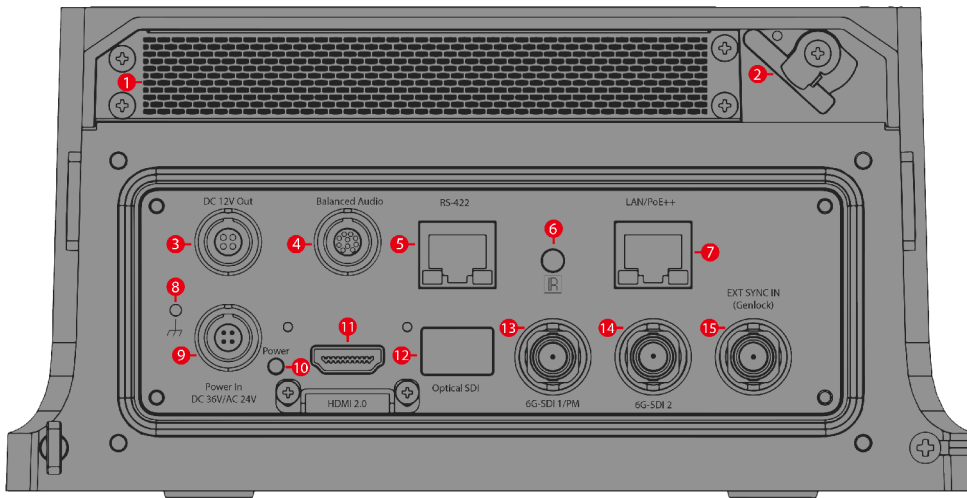
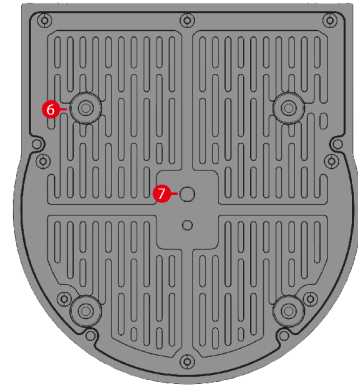

- 1 Fan
- 2 Fan Removal Tool
- 3 DC 12V Power Output
- 4 Balanced Audio Input & Output  
(10-Pin LEMO Connector)
- 5 RS422 Serial Port (RJ45)
- 6 IR Receiver
- 7 10/100/1000 LAN Port/PoE ++ Power In
- 8 GND
- 9 DC 36V/AV 24V Power Input
- 10 Power Indicator Light
- 11 HDMI 1.4/2.0 Output
- 12 Optical SDI SFP Slot
- 13 SDI Program Output 3G/6G/12G-SDI
- 14 SDI Output 3G/6G/12G-SDI
- 15 Genlock

 **NOTE: All dimensions listed below are in millimeters.**

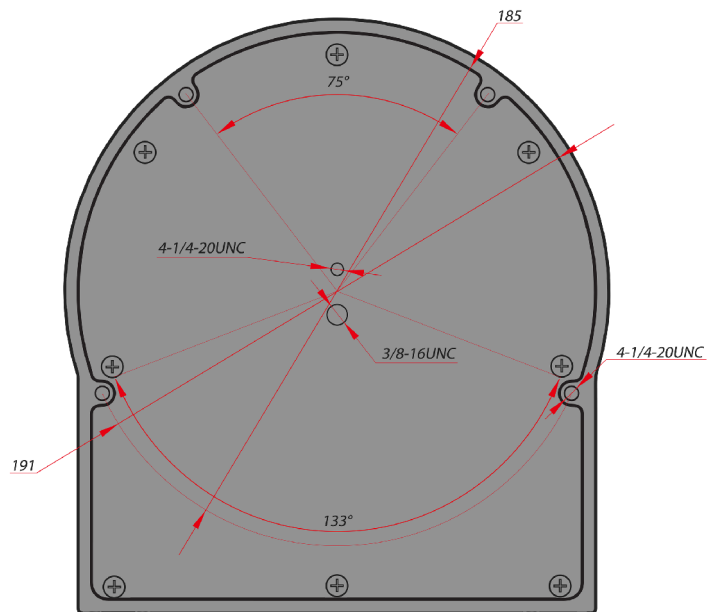
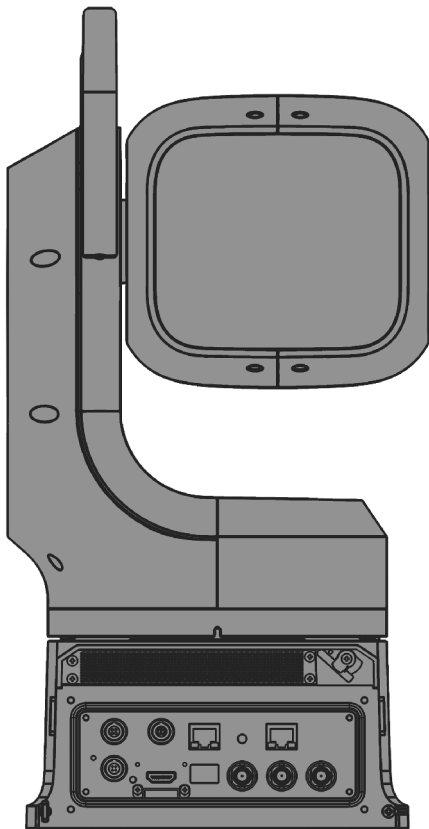
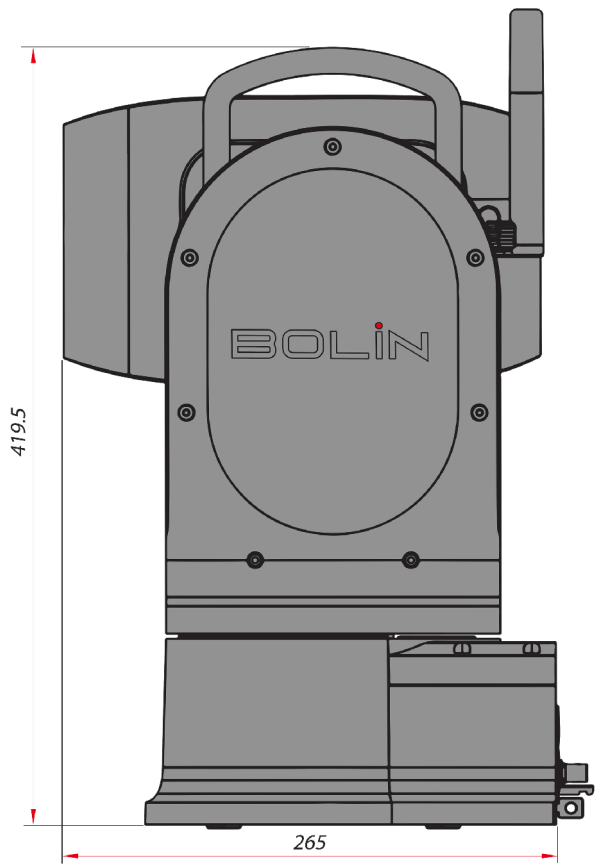
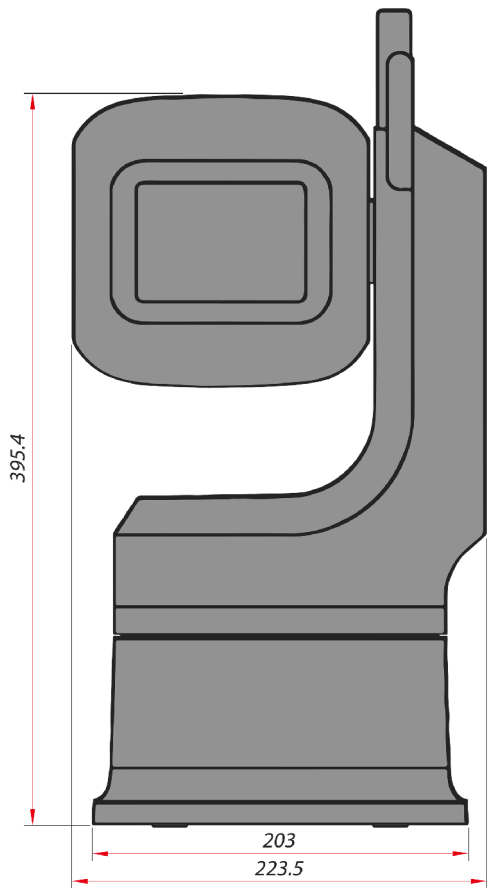



## Quick Start Guide

The EX-Ultra outdoor PTZ Camera has multiple connection options for video output, power input, control input, audio input and output, and synchronization. Users can choose the appropriate connection points based on user's requirements.

### Power

#### Power Options

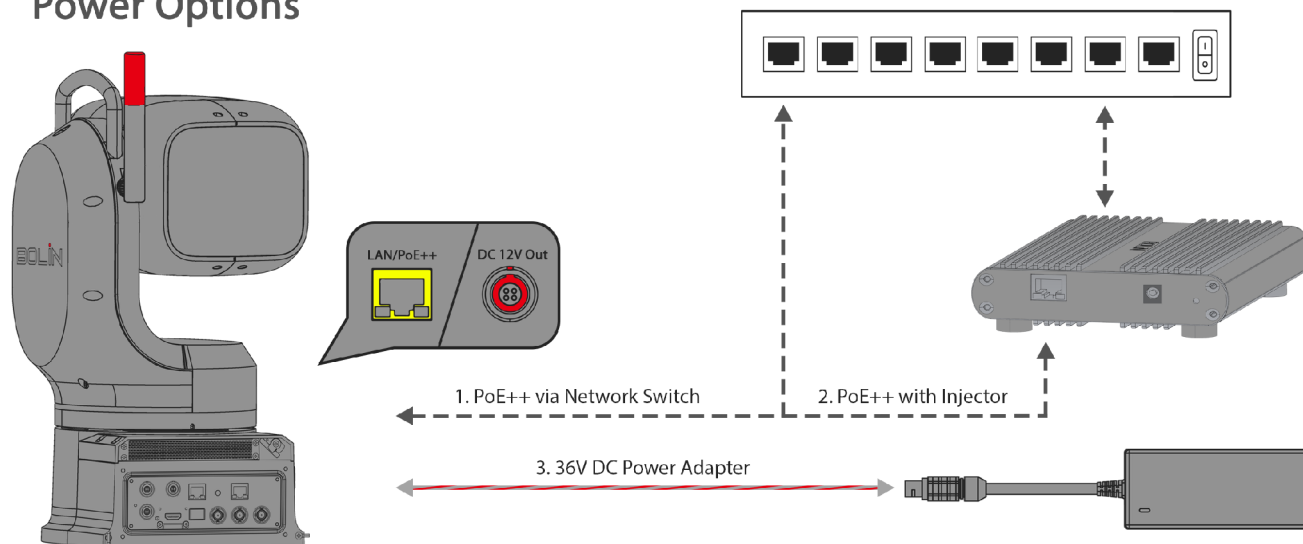

The camera can be powered two ways:

- 36VDC 4A Power Adapter (Part # P36-4), which is included in the box, plugged into the DC 36V Power In.
- PoE++(IEEE802.3bt, Type 4 Class8) through a Category 6 (CAT6) cable with RJ45 connector plugged into the 10/100/1000 LAN port. The other end of that CAT6 cable can be plugged in to a network switch that supports POE++ (90 Watts of Power Output per Port)

**NOTE:** If the network switch doesn't provide POE++ power, the Bolin's POE++ power injector can be used. (See below)



Bolin 36VDC 4A Power Adapter (P36-4)

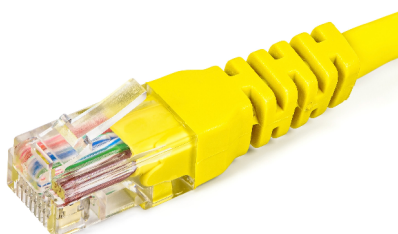

Category 6 (CAT6) Cable with RJ45 Connector



97W POE Injector (BL-PP97)

**CAUTION:** Only use the DC power adapter supplied with the camera. Do not use any other DC

power adapter.

 **CAUTION:** If using POE++ power, ensure that the POE power source has a sufficient power budget for the camera, or some features may not function properly. CAT6 cable runs from the camera to the POE power source has a limit of 90 meters before the signal and power loss occurs.

## Network

This camera offers a variety of functionalities via a network connection. Besides being powered over Ethernet, a network connection enables the user to adjust camera settings remotely, stream video from the camera to a distant location, and control the PTZ camera functions via the Web Interface. To connect the camera to the network, the user should adhere to the following steps:

1. Acquire a standard Category (CAT) 6 cable and insert one end of the cable into the camera. Connect the other end into a network switch.
2. Power on the camera.
3. To retrieve the IP address of the camera, the user should open the OSD Menu and navigate to the Status section. Alternatively, the user can download Bolin's IPC search tool from the website ([www.bolintechnology.com](http://www.bolintechnology.com)) onto a Windows computer and execute the tool to locate the camera on the network.
4. The user should ensure that their camera and computer are on the same subnet of the network to gain access to the Web Interface.

 **NOTE:** Factory-Default Camera Network Settings

Static IP Address: 192.168.0.13

Subnet Mask: 255.255.255.0

Gateway: 192.168.0.1

To change these settings, refer to the [Web Interface Configuration](#) section of this guide.

## Video Output

The EXU has multiple video outputs, which can be used simultaneously, and the resolutions can be configured independently. The outputs vary based on the camera model and are as follows :

### **HDMI Out (HDMI 1.4 in EXU-248F; HDMI 2.0 in EXU-420F)**

The user should follow these steps to connect the camera:

1. Connect one end of an HDMI cable that supports the required resolution to the HDMI Output of the camera. Connect the other end of the HDMI cable to the desired destination (Switcher, Converter, Display, etc.).
2. Power on the camera and wait for it to initialize. Once initialized, video will appear on the screen. For the first five seconds, the camera's initial settings will be displayed.
3. The user can utilize the OSD (On-Screen Display) Menu or Web Interface to set the desired output resolution and frame rate. For more information on how to configure these settings, please refer to the [Web Interface Configuration and System Menu](#) section of this guide.



**NOTE:** It is recommended for the user to utilize a certified "Premium High Speed HDMI" cable to guarantee the attainment of the maximum signal quality from their camera.

#### HDMI Standard Classifications

| HDMI Standard | Bandwidth           | Max Resolution Supported   |
|---------------|---------------------|----------------------------|
| HDMI 1.4      | 10.2 Gigabit/Second | 1080p, 120 Hz<br>4K, 30 Hz |
| HDMI 2.0      | 18.0 Gigabit/Second | 4K, 60 Hz                  |
| HDMI 2.1      | 48.0 Gigabit/Second | 8K, 120 Hz                 |

#### Dual SDI Out (6G-SDI in EXU-248F; 12G-SDI in EXU-420F)

1. Connect one end of an appropriately rated SDI cable to one of the two SDI outputs on the camera. Ensure to secure the BNC connector in place to prevent the cable from becoming loose during use. Connect the other end of the SDI cable to the desired destination (Switcher, Video Router, Converter, Display, etc.).
2. Power on the camera and wait for it to initialize. Once initialized, video will appear on the screen. For the first five seconds, the camera's initial settings will be displayed.
3. The user can utilize the OSD (On-Screen Display) Menu or Web Interface to set the desired output resolution and frame rate. For more information on how to configure these settings, please refer to the Web Interface Configuration and System Menu section of this guide.



**NOTE:** The SDI Output labeled as "Program Out" or "P/G Out" will only display the video and not any OSD Menu's or overlays.

#### SDI Standard Classifications

| SDI Standard | Bandwidth            | Resolution Supported |
|--------------|----------------------|----------------------|
| SD-SDI       | 270 Megabits/Second  | 480i                 |
| HD-SDI       | 1.485 Gigabit/Second | 720p / 1080i         |
| 3G-SDI       | 2.970 Gigabit/Second | 1080P, 60FPS         |
| 6G-SDI       | 6 Gigabit/Second     | 4K, 30FPS            |
| 12-SDI       | 12 Gigabit/Second    | 4K, 60FPS            |

#### Optical Fiber

Obtain (2x) single-mode 1310 nm SFP+ 12G optical modules (transceivers) with LC duplex fiber connectors to plug into each end of the signal chain. Additionally, acquire a single-mode duplex fiber cable with LC connectors that is the appropriate length for the user's requirements.

1. Insert one SFP+ module into the camera. Once the module is fully inserted, connect the fiber cable to the LC connectors of the module. Repeat these steps at the receiving end of the signal chain (Fiber Converter, Monitor, Recorder, etc.).



2. Power on the camera and wait for it to initialize. Once initialized, video will appear on the screen. For the first five seconds, the camera's initial settings will be displayed.
3. You can use the OSD (On-Screen Display) Menu or Web Interface to set the desired output resolution and frame rate. Please see the [Web Interface Configuration](#) and [System Menu](#) section of this guide for more information on how to configure these settings.
4. The user can utilize the OSD (On-Screen Display) Menu or Web Interface to set the desired output resolution and frame rate. For more information on how to configure these settings, please refer to the [Web Interface Configuration](#) and [System Menu](#) section of this guide.

After conducting thorough testing, we recommend the brands FS and LR-TECH for your needs. In particular, the 'LR-8910D-SDI-LR' model (Serial Number: BS190909052) was found to perform exceptionally well.

 **NOTE:** The resolution of the Optical Fiber is the same as the resolution set for the SDI outputs. These video outputs are not independent.

 **CAUTION:** Make sure you keep the LC connectors on the fiber cable and SFP modules covered when not in use. Leaving connectors uncovered could lead to damage and signal degradation.



SFP+ 12G Optical Modules

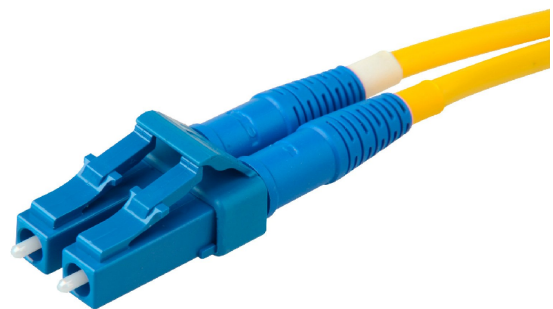

LC Duplex Fiber Connector

## IP Stream Out

The IP stream(s) can be enabled and configured from the Web Interface of the camera. The camera must be connected to a Local Area Network (LAN) using a CAT6 cable through either a switch or direct connection to a computer in order to access the web interface. Streaming from the camera requires internet (WAN) access. The following steps should be followed:

1. Connect the camera to the network by inserting one end of a CAT6 cable into the 10/100/1000 LAN port of the camera and the other end either into a switch or directly into a computer.
2. Open an HTML5-enabled web browser on a computer and enter the IP address of the camera. By default,

the camera is set to 192.168.0.13. The IP address can also be located under the “Status” menu of the camera’s On-Screen Display (OSD) or by using Bolin Technology’s IPC Search Tool in the Download Center.

3. Select “AV Setup” from the menu on the left-side of the Web Interface. From here, enable and configure the IP streams as needed. For more details, refer to the “Web Interface Configuration” section of this user guide.

## Control Input

The EX-Ultra PTZ cameras have multiple ways of being controlled that can be used simultaneously to provide the user with the flexibility they need for their setup. The control methods are as follows :

### **Infrared (IR) Remote Controller**

The remote operates optimally from short distances and must be in line-of-sight with the camera. The I/O panel of the camera has a built-in IR receiver to accept commands from the remote. To use the IR Controller, the user should follow these steps:

1. Before powering on the camera, the user should select the IR channel they would like to use to control the camera by using the IR Channel Selector on the back of the camera. They can choose from channels 1-3. If the user has multiple cameras, it is best to set up cameras that will be close together to different IR channels to avoid unwanted changes being made. Once the channel has been selected, the user should power on the camera.
2. On the IR remote, the user should select the “Camera IR ID” that matches with the channel that the camera has been set to. Now the user is ready to use the remote to configure/control the camera.

When the user is using the IR Remote, they should make sure to either power off any nearby cameras or set them to a different IR ID. If there are cameras within range that are set to the same IR ID, their settings might be altered.

### **Functions of the IR Controller:**

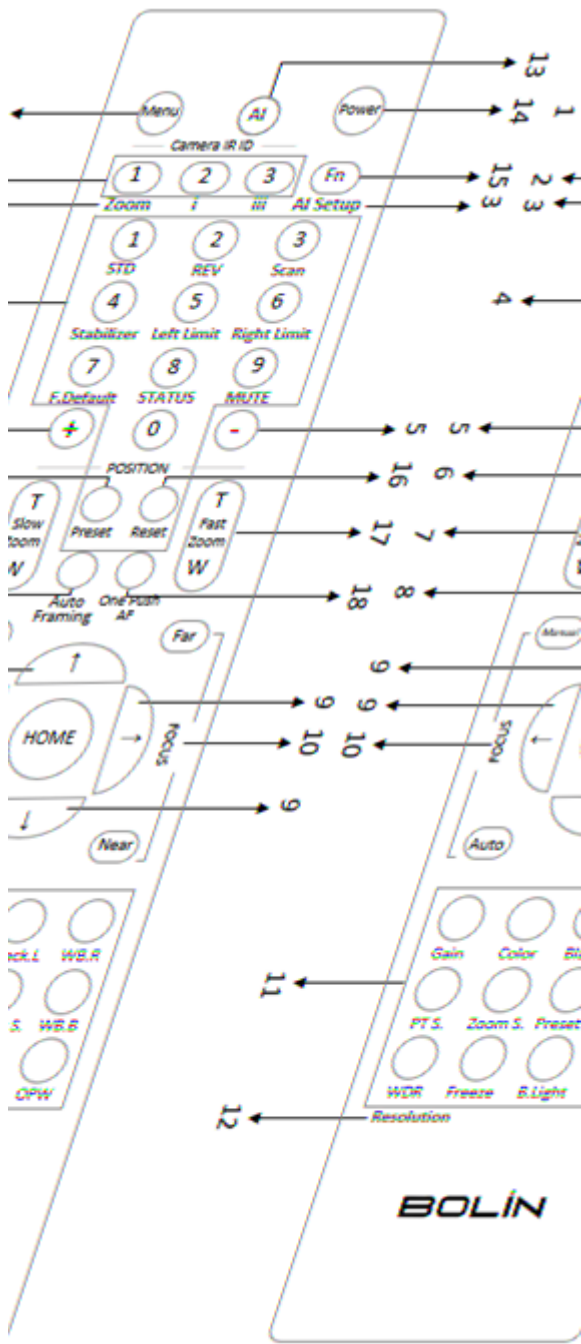

1. **Menu** - On-Screen Display (OSD) Toggle
2. **IR ID Selector** - Select which IR Channel (Camera) to be controlled
3. **AI Function Buttons** - Disabled
4. **Buttons 1-9** - Used to set & recall corresponding presets. (See #6 to set a preset and #16 to erase a preset)
5. **+ & - Buttons** - Used in conjunction with image adjustment buttons (11) to increase or decrease parameters.
6. **Preset** - To save a preset, hold down the "Preset" button and the preset number you would like to assign it to.
7. **Slow Zoom** - Zoom's the camera in or out in a slow speed.
8. **Auto Framing** - Disabled

9. **Direction Arrows** - Pan and Tilt the camera in the corresponding direction. Navigate the OSD Menu when open.
10. **Focus Adjustments** - Use the "Auto" button to enable autofocus. To make manual focus adjustments, press the "Manual" button first, followed by the "Far" or "Near" buttons to adjust.
11. **Image Adjustments** - Select the property you would like to adjust, followed by the + and - buttons (5) to make the appropriate adjustment, unless otherwise noted below. The selected function and corresponding options will glow when selected.
  - **Gain** - Image gain settings
  - **Color** - Color saturation settings
  - **Black.L** - Image black level settings
  - **WB.R** - White Balance, Red settings
  - **PT.S** - Pan/Tilt speed settings
  - **Zoom.S** - Zoom speed settings
  - **Preset.S** - Preset speed settings
  - **WB.B** - White Balance, Blue settings
  - **WDR** - Wide Dynamic Range Settings
  - **Freeze** - Freeze the video on the current frame. (Doesn't use + and - buttons)
  - **B.Light** - Back light compensation
  - **OPW** - One Push White Balance (Hold the button down while pointing the camera at a gray card to set white balance.)
12. **Resolution** - Used to change the video format/resolution. Press and hold the Fn button (15) and Resolution button to select the desired format. The image block will restart after the format is changed, and the screen will go black for a few seconds.
13. **AI Button** - Disabled
14. **Power** - Press and hold for three seconds to turn the camera on/off.
15. **Fn Button** - Press and hold in conjunction with other buttons in dark brown text (Stabilizer, Mute, Scan, etc...) to adjust parameters.

### RS-422 Serial Commands (VISCA)

The camera is equipped with an RS-422 port that facilitates VISCA control over serial commands. Additionally, the RS-422 port is compatible with RS-485. The user can establish a serial connection between the camera and a PTZ controller or computer to execute pan, tilt, and zoom operations, as well as perform preset recalls.

 **CAUTION:** Establishing a serial connection between the camera and a Sony PTZ controller differs from the process with a non-Sony PTZ controller. It is crucial to verify the pin settings for the specific controller in use.

1. The camera should be powered on and the OSD menu opened or the Web Interface logged into any web browser. Proceed to the system settings and adjust the baud rate to match that of the controller's baud

rate. The VISCA ID should be set to a number between 1-7.

2. A standard terminated CAT5 or CAT6 cable can be used to directly connect the camera to the controller, or the included RJ45 to RS422 Control Cable Adapter can be used to connect unterminated CAT5/CAT6 cables between the camera and controller. The pin connection diagrams provided below should be followed, based on the specific controller in use and the desired connection.

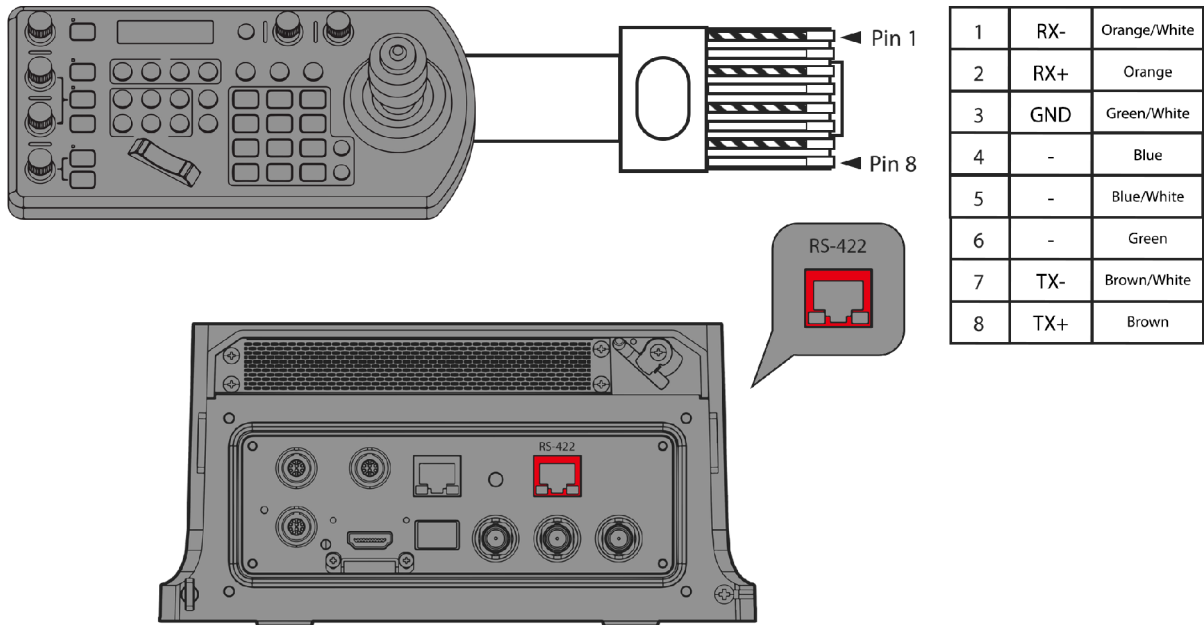

NOTE: Please refer to the KBD-1010-RNV user guide for instructions on how to establish an RS422 connection with the controller.

### Use RS-422 (VISCA) / RS485 (PELCO P/D)

For camera operations, the RS-422/485 port can be utilized to connect controllers, such as a joystick keyboard or a PC station. This allows for the effortless management of pan, tilt, and zoom functions, as well as access to all preset functions using the controller's buttons.

To utilize a PC station, it is essential to have a software application that is compatible with this unit.

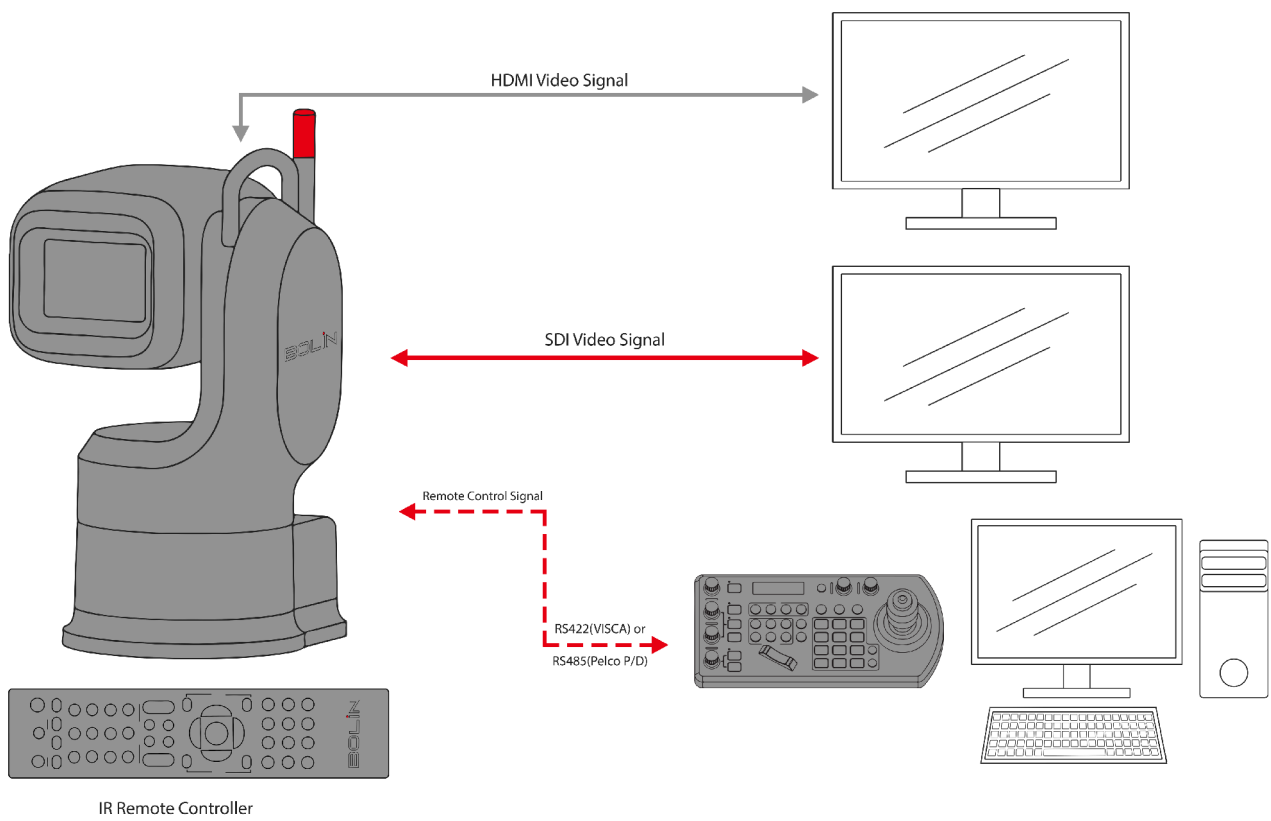

### SONY Keyboard RS422 Connection

Guide for Establishing RS422 Connection and Daisy Chain Configuration for Multiple Cameras with a SONY Controller.

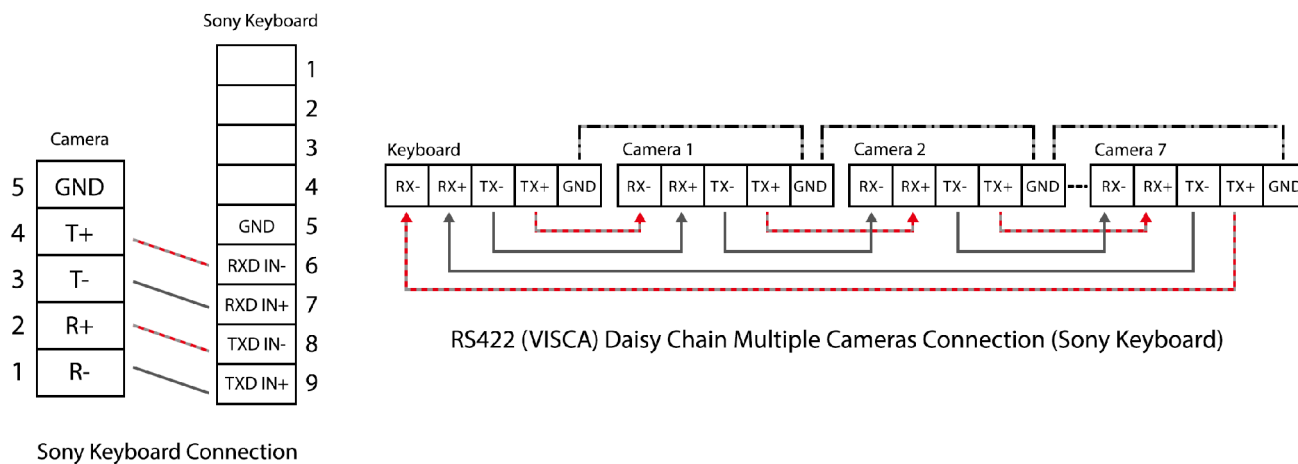

### VISCA (Non-Sony) Keyboard RS422 Connection

Guide for Establishing RS422 Connection and Daisy Chain Configuration for Multiple Cameras with a Non-Sony Controller:

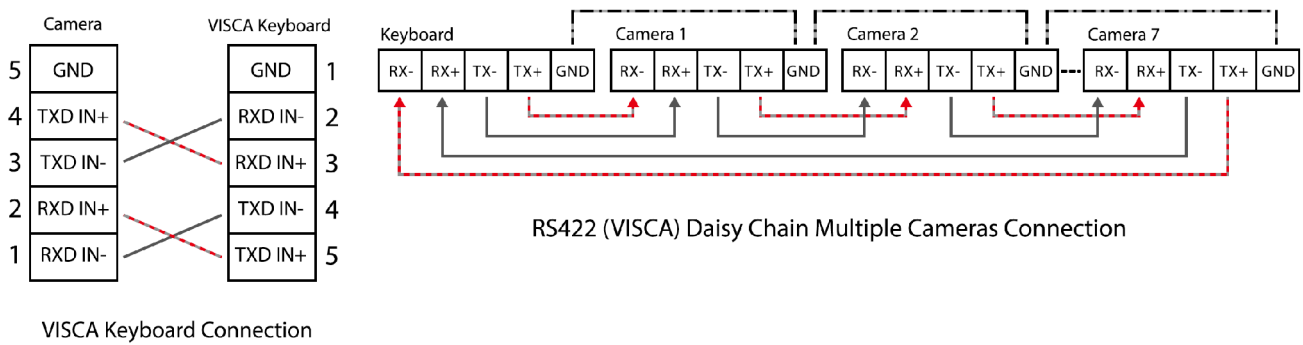

The user is advised to use the included extension cables, which come with an RJ45 to RS422 Phoenix connector adapter, to set up an RS422 connection for the control device. This will ensure a stable and reliable connection for controlling the device.

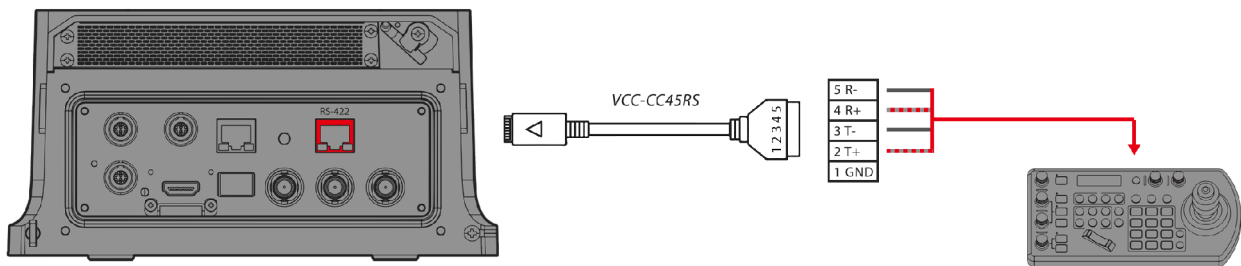

NOTE: Please refer to the KBD-1010-RNV user guide for instructions on how to establish an RS422 connection with the controller.

Guide to creating an RS422 Daisy Chain Connection for Multiple Cameras with an RS422 Standard Serial Port Controller.

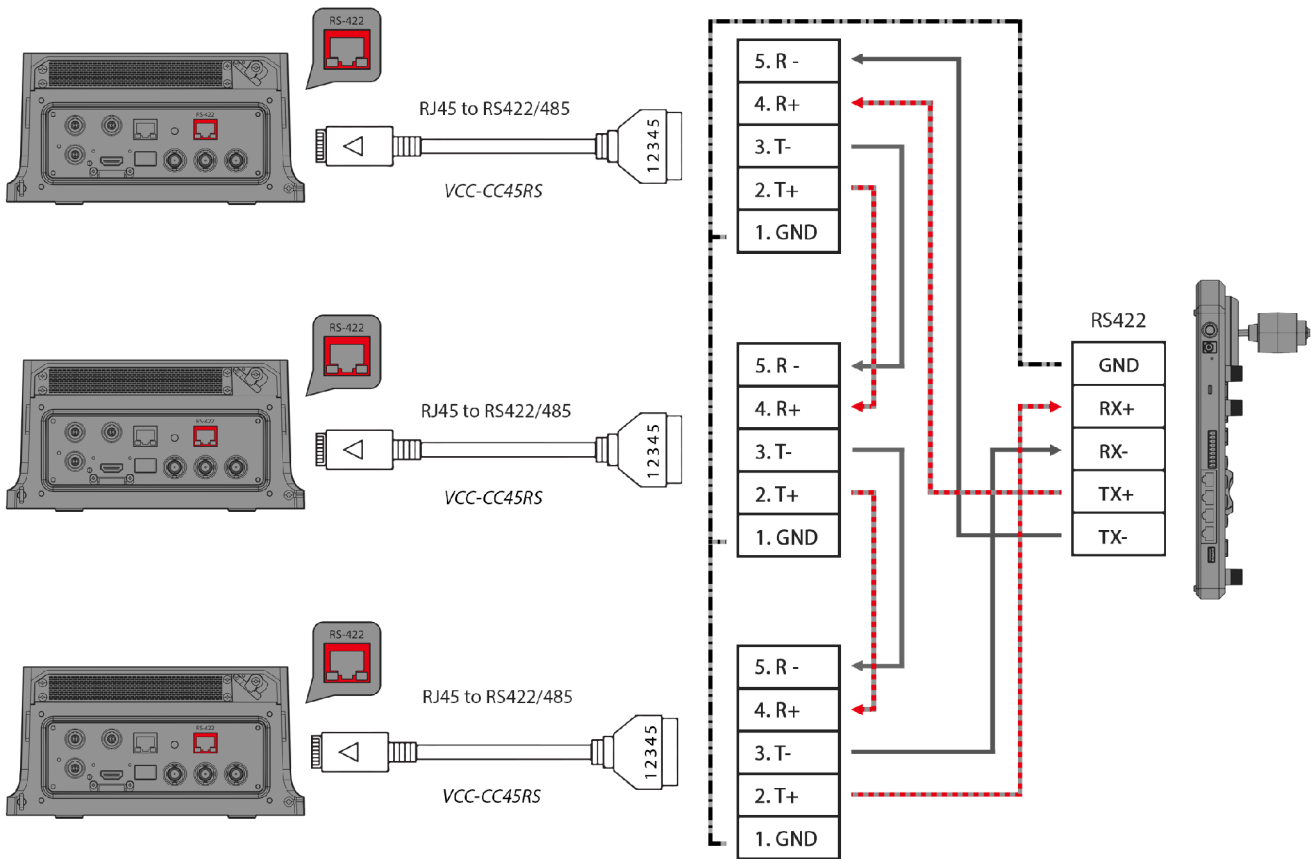

### PELCO P/D Keyboard RS485 Connection

**Important:** Utilize RS422 ports when establishing an RS485 connection. Only employ TX+ and TX- for RS485 connections.

- Set the RS422 control method using the OSD menu or Web interface.
- Set the camera ID on the OSD menu using the remote controller.
- To ensure the settings have been applied, restart the camera by switching it off and then back on.
- Use a PELCO P/D compatible keyboard for seamless integration.
- Utilize preset # 95 on the keyboard to access/exit the camera OSD menu.
- Navigate the OSD menu using the joystick and buttons "OPEN" or "CLOSE."
- For the keyboard operation details, refer to the user manual of the specific keyboard in use.

### PELCO RS485 Connection

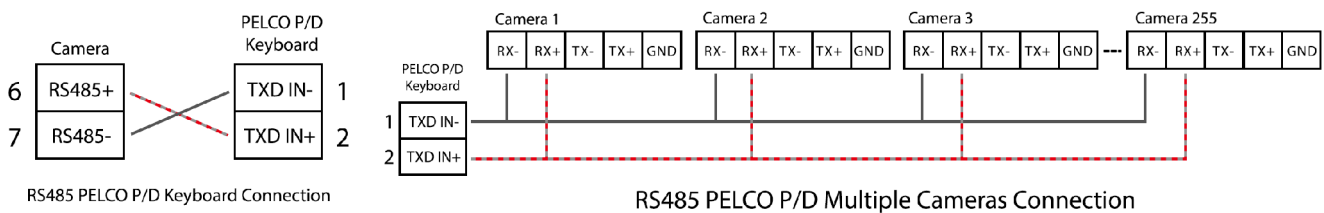

Extension cables that come with an RJ45 to RS422 Phoenix connector adapter can be utilized to establish an RS485 connection for the control device.



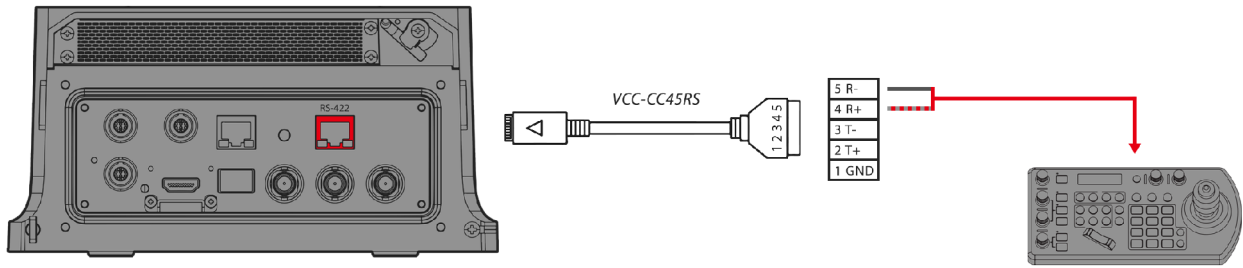

NOTE: Please refer to the KBD-1010-RNV user guide for instructions on how to establish an RS422 connection with the controller.

The included extension cables, equipped with an RJ45 to RS422 Phoenix connector adapter, can be utilized to establish an RS422 connection for the control device.

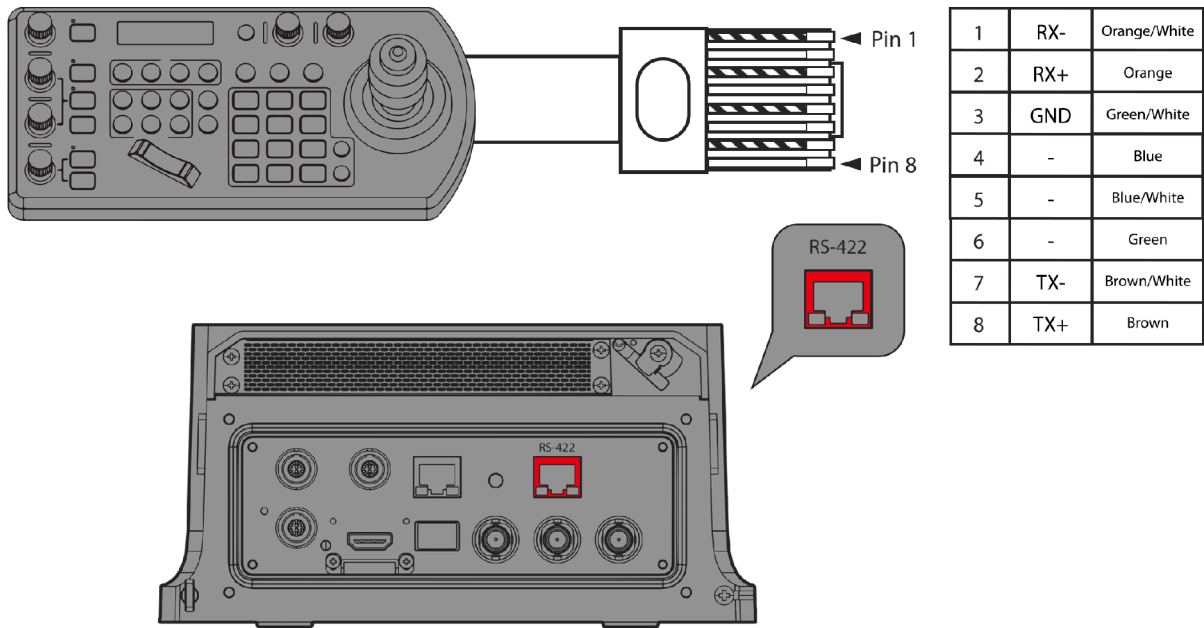

NOTE: Please refer to the KBD-1010-RNV user guide for instructions on how to establish an RS422 connection with the controller.

Alternatively, an RS485 connection can be established by directly connecting the camera and the controller using a CAT5/6 T-568B Standard Ethernet cable.

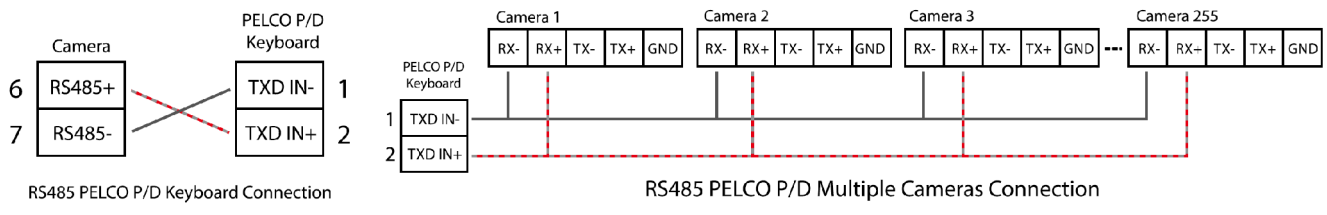
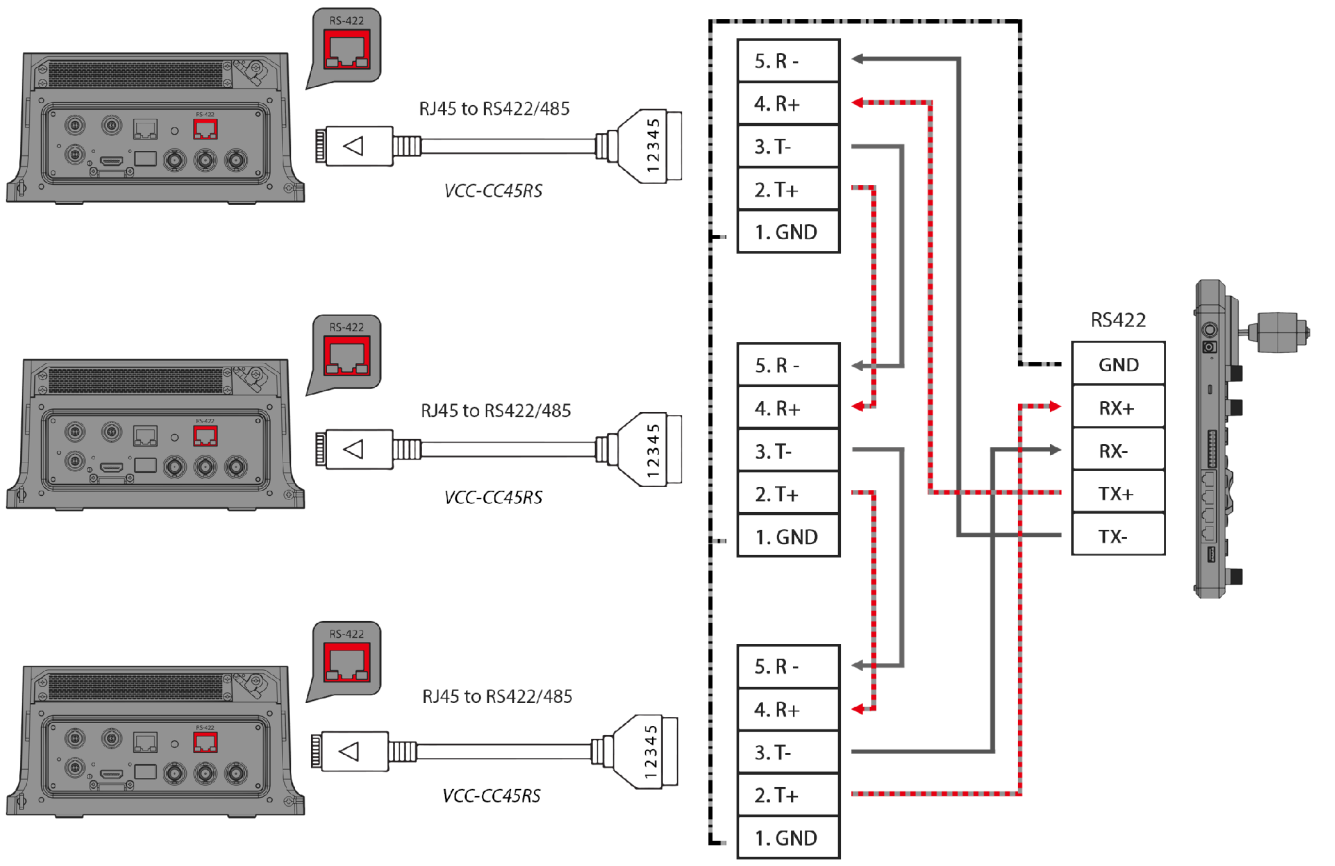

### VISCA over IP

Using VISCA over IP allows users to control the camera from anywhere that is on the same LAN as the camera. It involves connecting the PTZ camera to a network switch. The steps are as follows:

1. **Connecting the Camera to the Network:** Insert one end of a CAT6 cable into the 10/100/1000 LAN port of the camera and the other end into a network switch.
2. **Configuring the Camera's Network Settings:** Adjust the camera's IP address and related network settings to ensure proper communication with the network and PTZ Controller.
3. **Connecting the PTZ Controller to the Network:** Connect a PTZ Controller that supports VISCA over IP to the network using a CAT6 cable.
4. **Configuring the Controller's Network Settings:** Adjust the controller's IP address and related network settings to ensure proper communication with the network and PTZ camera. Then, input the camera's IP address and VISCA over IP port settings into the controller to access the camera.

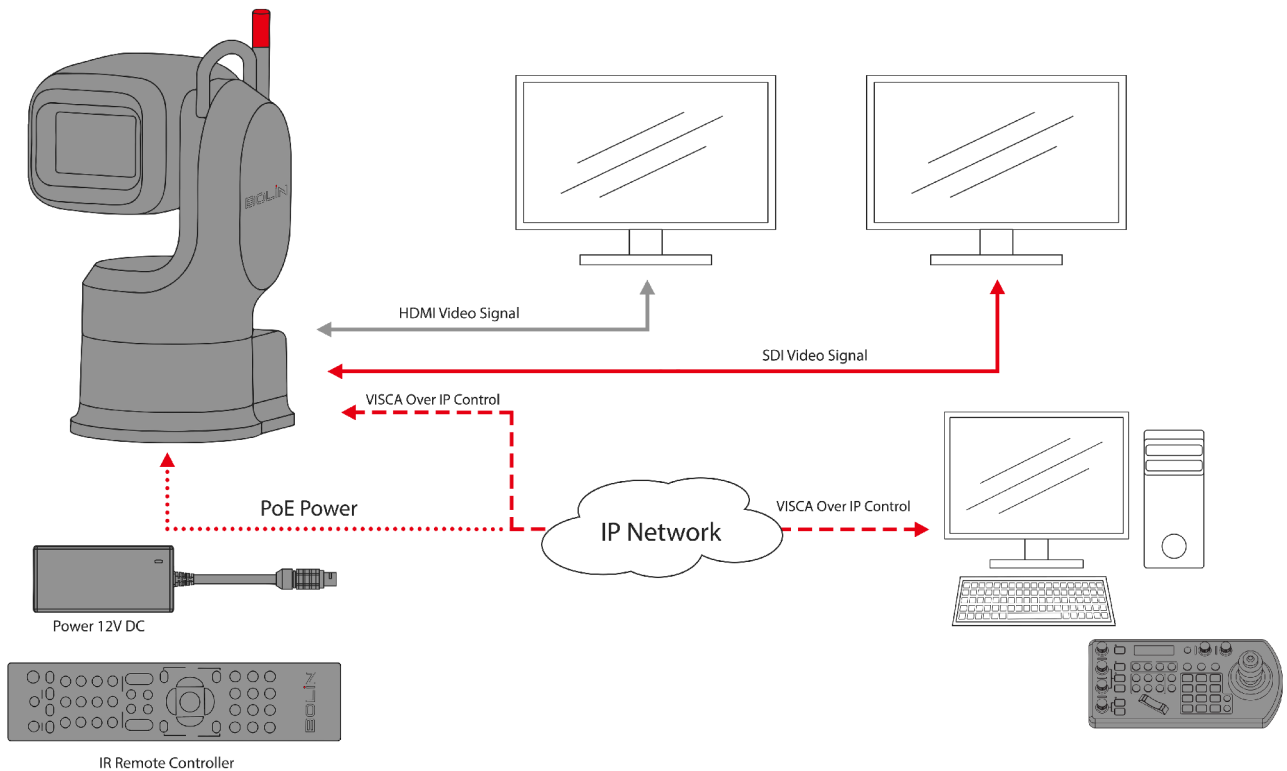

**NOTE: Factory-Default Camera Settings for control of VISCA over IP**

Static IP Address: 192.168.0.13  
 Subnet Mask: 255.255.255.0  
 Gateway: 192.168.0.1  
 VISCA over IP Control Port: 52831

To change these settings, refer to the Web Interface Configuration section of this guide.

**NOTE: The VISCA over IP port of the controller MUST be set to 52381 to communicate with and control the camera.**

### ONVIF Protocol

Can be easily integrated with other ONVIF-compliant devices and systems. This allows for greater flexibility and ease of use, especially with setups that involve multiple devices and systems.

ONVIF 2.4 (Profile S/G/T)

ONVIF Port: 80

### Audio Input

The camera features an industry-standard 10-pin LEMO connector to embed balanced audio. Users can choose to use a third-party breakout cable or purchase Bolin's 10-Pin LEMO to XLR breakout cable (BLA-10). Once connected and activated from the Web Interface or OSD Menu, the audio will be embedded into the camera's HDMI, SDI, and IP streams. To connect an audio source to the camera, follow these steps:

1. Obtain a 10-pin LEMO to XLR breakout cable. Plug the male LEMO connector of the breakout cable into the female LEMO connector that is labeled as "Balanced Audio In/Out" on the back of the camera.
2. Using XLR cables, connect the output of the audio source (microphone, audio mixer, speaker, etc...) into the two female XLR connectors of the breakout cable.

3. To enable the audio and configure the audio levels, log into the camera's web interface or open the OSD menu.

 **CAUTION:** It is crucial to enable the audio input through the Web Interface or OSD Menu. Failing to do so will result in video streams without audio.

 **NOTE:** Disregard the two male XLR connectors on the breakout cable. The audio output through XLR is not active.

## Synchronization (Genlock)

Genlock (Generator Locking) is an external synchronization signal input, which supports BBS (Black Burst Sync) and tri-level synchronization. External synchronization (genlock) can be applied to achieve precise frequency-locked video signals where every device (audio and video) knows when a frame starts and ends. Genlock is an industry standard and conforms to SMPTE standards.

To connect a genlock signal to your camera, follow these steps:

1. Connect one end of a 75-ohm SDI cable with BNC connectors into the "Genlock" port of the camera.
2. Connect the other end of the 75-ohm SDI cable with BNC connectors to a device that is outputting the Genlock signal or providing timing reference (Sync Generator, Video Switcher, Audio Mixer, etc...)
3. Open the camera's OSD menu and turn on External Synchronization. Other Genlock settings can be configured in this menu as well.

 **CAUTION:** Once the Genlock cable is connected, make sure to enable Genlock in the camera's menu. Otherwise, the camera may not be synchronized with the rest of the system.

 **NOTE:** External synchronization is performed using SDI only. Synchronization is not possible using the HDMI video signal or the IP video signal.

## Tally Light

### Tally Light GPI I/O connection

The camera is equipped with a removable tally light, serving as a visual indicator. When illuminated, this light signal that the camera is actively operational. To activate the camera's Tally Light function, you need a video switch and a keyboard (not included).

### GPI connection with RS422 VISCA control connection

#### Cable Configuration:

1. Set up a standardized RS-422 daisy chain control connection to seamlessly control multiple cameras from the keyboard controller. (For detailed RS422 control information, refer to the Keyboard Controller user guide.)
2. Established a Tally/Contact Function cable connection between the Keyboard Controller and the Video Switcher (Sony).

## Keyboard Side

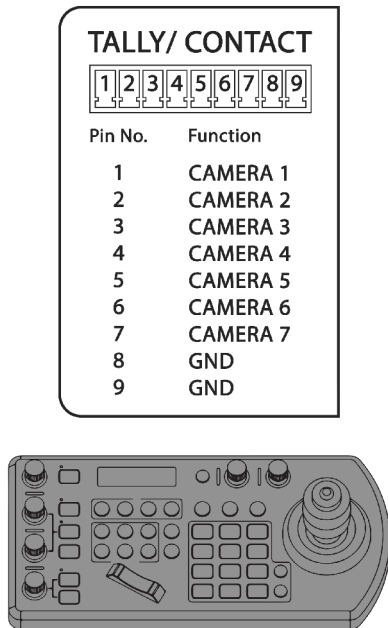

## Video Switch Side

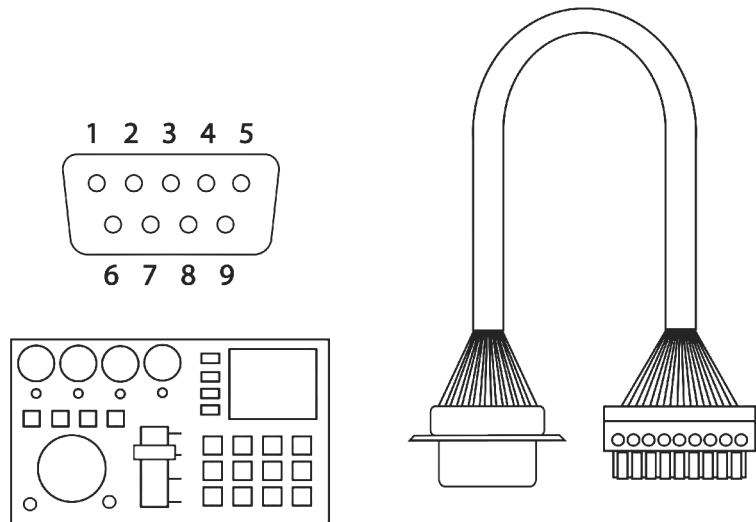

1. On the keyboard side, connect pins 1-8. On the Video Switch side, connect pins 1-9, excluding pin 8.
2. Link keyboard pin 8 with video switch pin 9.
3. Connect keyboard pin 1 to video switch pin 1, pin 2 to pin 2, and continue similarly (you can decide the rest based on the pattern), ensuring pin 7 is connected to pin 7.

### Set Up

1. GPI I/O Input Mode for Tally Signal from Video Switch:
  - a. Connect the camera to the keyboard using a standard RS-422 control cable.
  - b. Establish a connection between the keyboard and the video switch using a tally function cable.
  - c. Navigate to **KEYBOARD SETTING > GPI I/O > Setting**, and switch it to Input mode. Exit to the home directory.
  - d. After completing the above steps, you can switch between cameras using the video switch. For instance, selecting camera 1 on the video switch sends a tally signal to the keyboard via the tally function cable. The keyboard then transmits this tally signal to camera 1 through the standard RS-422 control cable, activating camera 1's tally light. The keyboard can now control camera 1's pan and zoom.
  - e. If you switch to camera 2 on the video switch, the tally light for camera 2 will turn on, and the tally light for camera 1 will turn off.

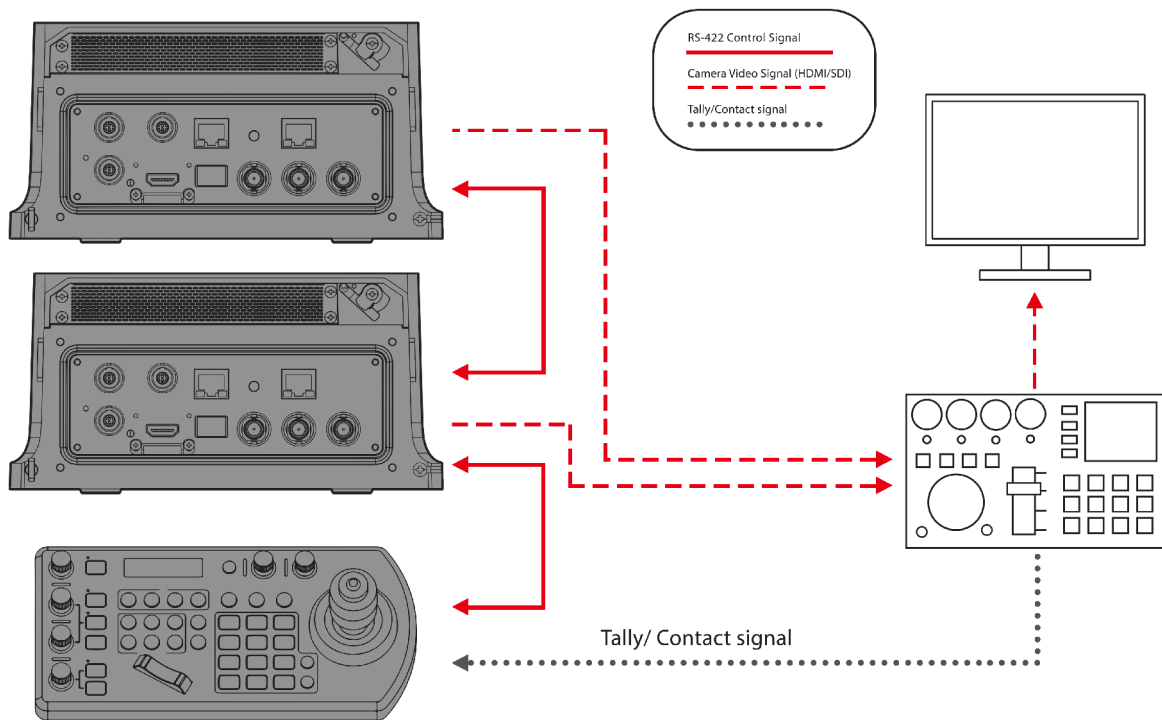

## 2. GPI I/O Output Mode for Tally Signal Sent by Keyboard Controller:

- Connect the camera to the keyboard using a standard RS-422 control cable.
- Navigate to **KEYBOARD SETTING > GPI I/O > Setting**, and switch it to Output mode. Exit directly to the home menu.
- After completing the above operation, you can switch between different cameras using the keyboard. For instance, selecting camera 1 on the keyboard sends a tally signal to camera 1 via the standard RS-422 control cable. As a result, camera 1's tally light turns on, and the keyboard gains control over camera 1's pan and zoom.
- If you switch to camera 2 on the keyboard, the tally light for camera 2 will turn on, and the tally light for camera 1 will turn off.

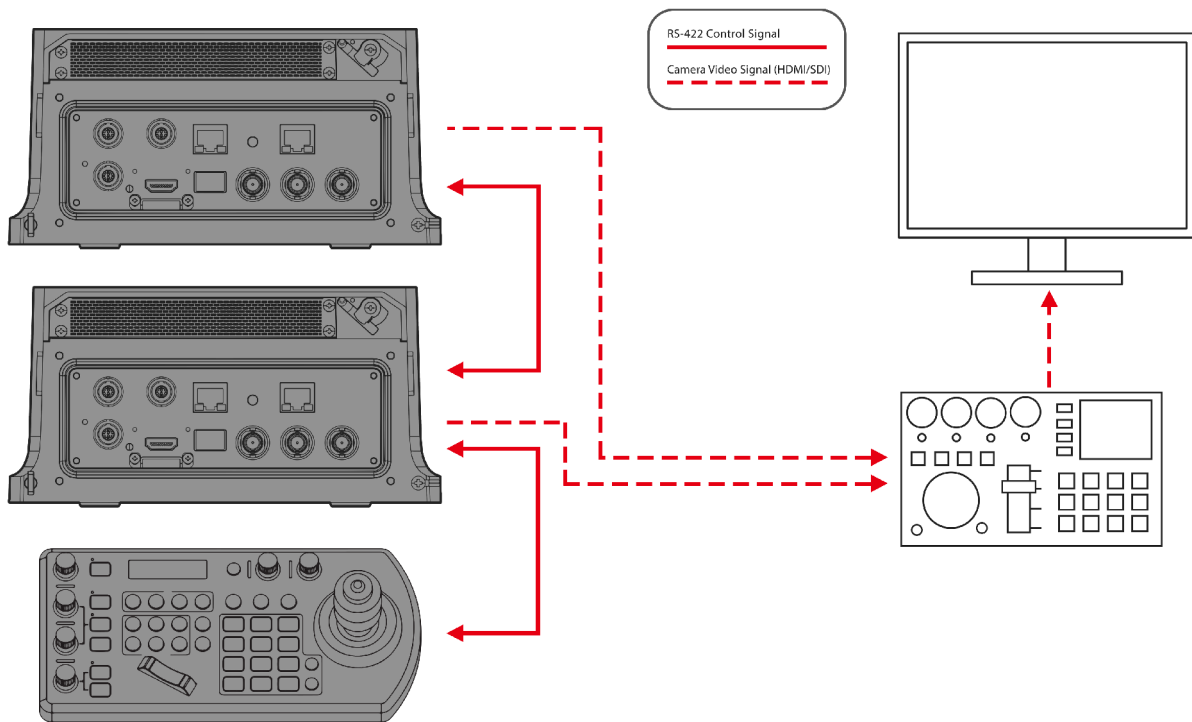

### Installing the Tally Light on the PTZ Camera

Follow these steps to install the tally light on your PTZ camera:

1. **Locating the Tally Light Port:** The tally light port is located on the back of the camera, behind the camera's handle, and is covered by a metal cover.
2. **Unscrewing the Metal Piece:** The metal cover should be carefully unscrewed to reveal the slot for the tally light. This metal piece is attached to the camera with a small cable.
3. **Attaching the Tally Light:** The tally light should be aligned and inserted into the port. An arrow on the tally light indicates where to twist to secure it.
4. **Replacing the Metal Cover:** The metal cover that was removed earlier can now be attached underneath the tally light. As it is magnetic, it should attach easily and stay in place.

## Web Interface Configuration

Once connected to the network, the camera can be configured and controlled through the web interface on any web browser that supports HTML5. This next section will explain the various sections of the web interface and what they can do.

### Web Interface Login

To log in to the web interface, the user should first ensure that the camera is connected to the network and that the user's computer is on the same subnet as the camera.

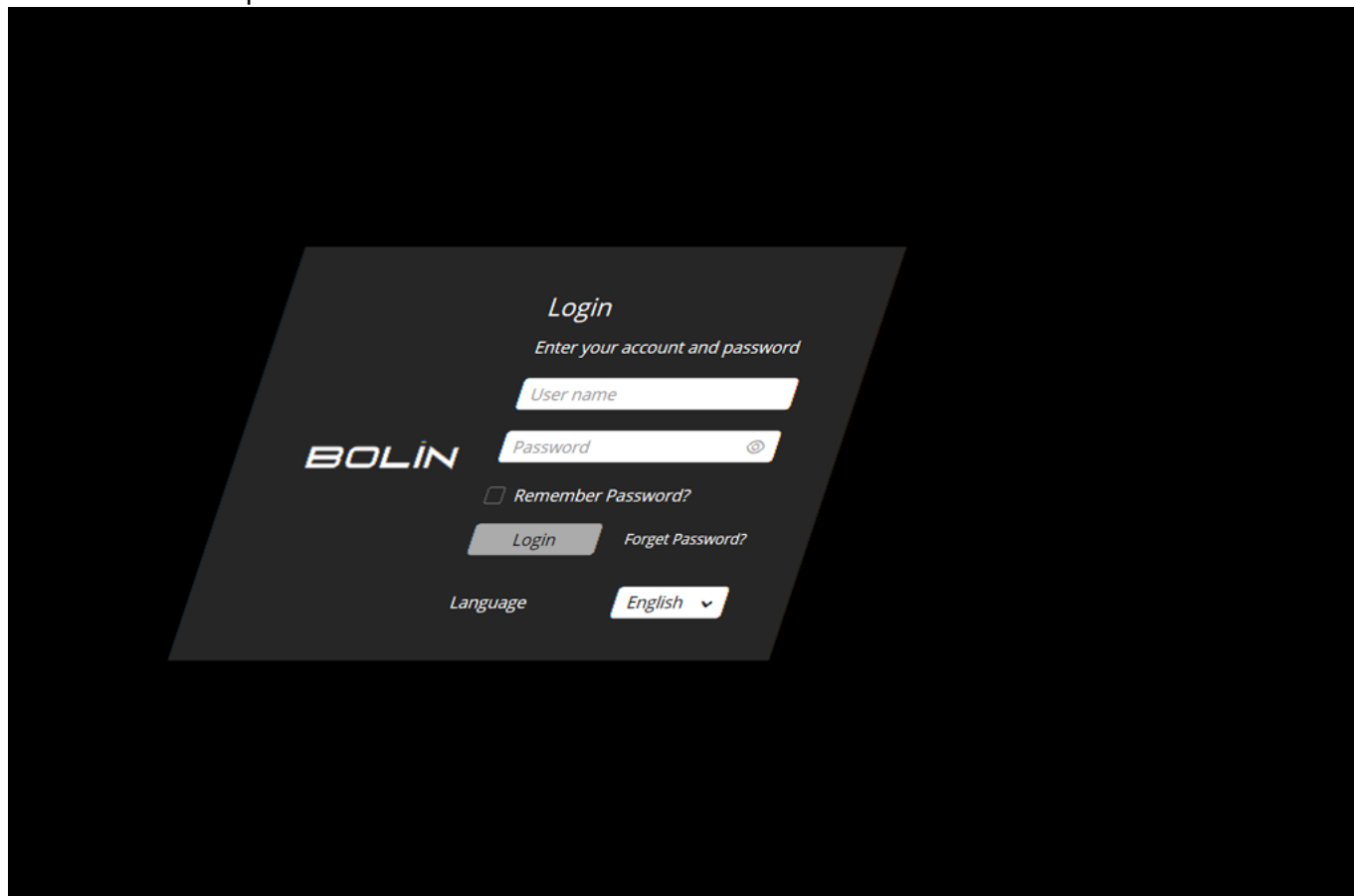

#### Factory-Default Camera Network Settings:

Static IP Address: **192.168.0.13**

Subnet Mask: **255.255.255.0**

Gateway: **192.168.0.1**

 **NOTE:** To obtain the IP address of the camera, open the OSD Menu and scroll down to the Status section. Alternatively, download Bolin's IPC search tool from the website ([www.bolintechnology.com](http://www.bolintechnology.com)) onto a Windows computer and run the tool to discover the camera on the network.

1. Once the camera's IP address has been obtained, the user should enter it into the web browser on their computer.
2. The user will be prompted to enter a username and password. By default, the credentials are:  
**Username: admin**  
**Password: admin**

 **NOTE:** The first time you log in to the web interface, you will be prompted to set a new password. For best security practices, enter a password that is at least 8 digits long, and



contains one capital letter, one lowercase letter, one number, and one symbol.

3. Once the user enters the credentials, they should press the login button.

**NOTE: Forgot Your Password?** If the user forgets/loses the password to their camera, our support team can help them recover it. The user must first download the IPCSearch tool from our website ([www.bolintechnology.com](http://www.bolintechnology.com)) onto a Windows computer that is on the same subnet as the camera. Then, run the tool to search for their camera. Select the camera that they wish to recover and click the “Forgot Password” button at the bottom of the window.

The program will provide the user with a generated key. Email “[support@bolintechnology.com](mailto:support@bolintechnology.com)” with the key. Our support team will generate and provide the user with a temporary password that is valid for only 24 hours. The user should enter this temporary password to create a new password within 24 hours of receiving the key, otherwise, they will need to follow this procedure again. The user should not turn their camera off while waiting to receive the temporary password, otherwise, the temporary password associated with the key will become invalid.

## Live View

Once logged in to the camera, the home page is the Live View page.

On the “Live View” page, the user has access to the following features:

- Viewing a preview of the video output (Please note, this feed will be delayed by 1–2 seconds.)
- Adjusting and controlling PTZ functions
- Setting and recalling camera presets
- Accessing the OSD Menu Settings directly without the need to open the OSD Menu

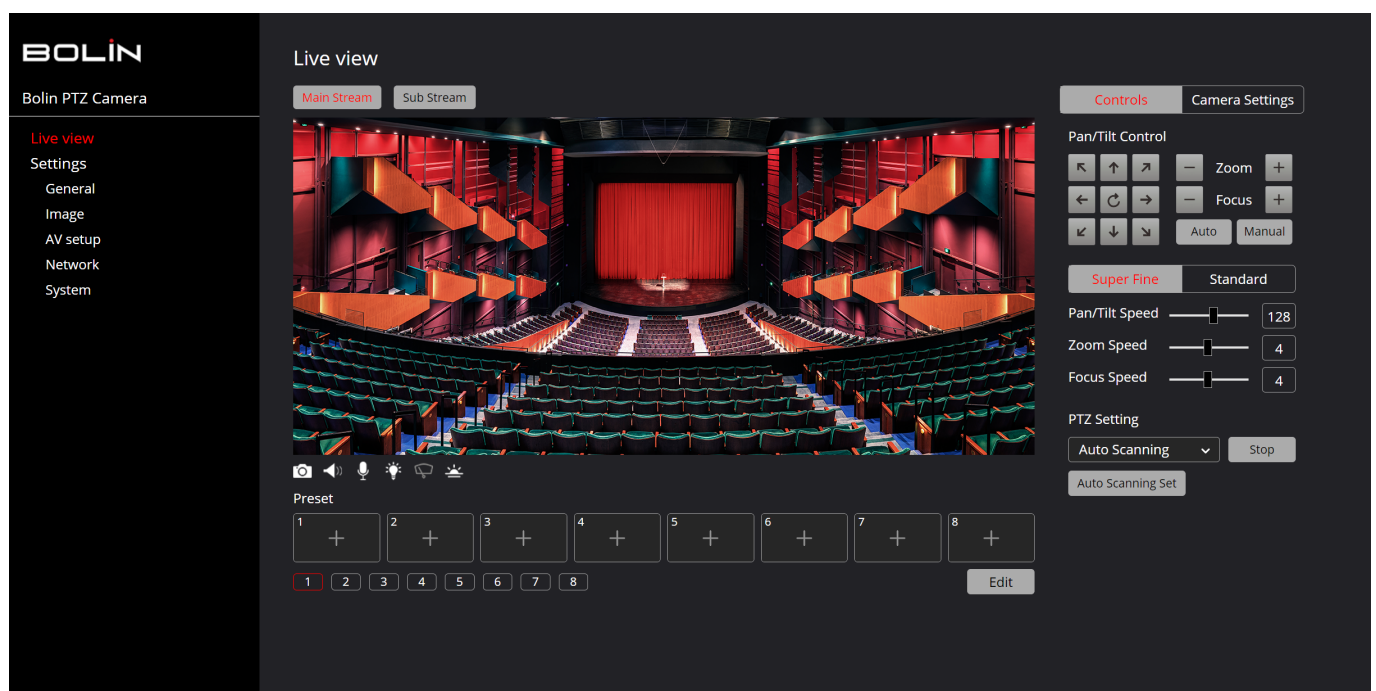

Below the Live View image, the user will find the following icons:

- **Snap Live View Images:** This allows the user to capture images from the live view.

- **Mute Audio:** This will silence the audio.
- **Microphone ON/OFF:** This controls the microphone's status, allowing the user to turn it on or off.
- **IIR Laser Illuminator ON/OFF:** This controls the IR Laser Illuminator, enabling the user to turn it on or off. It enhances the camera's ability to record high-resolution video in low-light conditions. The adaptive IR Laser can be synchronized with different zoom angles. Illumination distance is up to 500 meters.
- **Wiper ON/OFF:** This controls the wiper, allowing the user to turn it on or off.
- **Defog ON/OFF:** This controls the defogging feature, enabling the user to turn it on or off.

### Adjusting and Controlling PTZ Functions

On the right side of the "Live View" page (under Controls) and the "Image" page, there is a set of arrows and sliders that can be utilized to control the camera.

- Use the arrows to pan and tilt the camera in its desired motion. The focus and zoom buttons allow you to zoom in (+) or out (-) and focus closer (+) or further (-) in manual mode. There are two modes of controlling the camera: Super Fine and Standard. Super Fine can be used for more precise, granular control, while Standard should be used for quick, general adjustments. The speed setting sliders can be used to modify the speed of pan, tilt, focus, and zoom accordingly.
- **Auto-Scanning:** The camera image pans left to right or right to left automatically at a user-defined speed (Speeds 1-8).
- **Scanning:** The camera image pans left to right or right to left between up to 12 user-defined points at a user-defined speed (Speeds 1-8).
- **Trace:** The camera will record a series of presets that are recalled in a specified order.
- **Cruise:** The camera will record a series of movements that an operator makes, which can then be recalled whenever a user likes.
- **Power-On Action:** Users can define a set of actions that a camera does (preset recall, scan, trace, or cruise) once powered on.

### Setting and Recalling Presets

Through the camera's web interface, the user can set and recall up to 64 camera presets. With the use of Bolin's KBD-1010, users can save up to 255 presets on the controller. These presets can then be recalled through the web interface, IR Remote, or PTZ Controller. To save presets, the user should follow these steps:

- Using the PTZ controls of the web interface, IR controller, or a PTZ controller, the user should adjust the camera to the position(s) they'd like to save as a preset.
- Once in position, the user should press the + button on the preset number to which they'd like to save the setting under the Preset section (below the Live View video stream). Optionally, the user can name the preset for the Web Interface. When the preset has been saved, the camera will take a snapshot of the preset view and display it as a thumbnail.
- To edit a saved preset, the user should move the camera into the desired position, select the preset they'd like to change, and click on the "Edit" button. The user should press Save to finalize changes.
- To recall a preset, the user should select the preset number on the Web Interface and click the "Go To" button.

### Using the Wiper

**Through the Web GUI:** The icon for enabling the wiper is located under the live view image on the live view

page of the camera's web interface.

Using the Controller (KBD-1010-RNV): To enable the wiper on the PTZ using a controller or web interface, one should set preset 62, which will trigger the wiper. To disable the wiper, one should recall preset 62.

### Adjusting OSD Menu Settings from the Web Interface

Instead of disrupting a video feed by bringing up the camera's OSD Menu, users can choose to view/modify the OSD Menu settings from the Web Interface. Under the "Live View" page, there is a tab for Camera Settings which gives users all the options they would find under the OSD Menu.

- Adjust Exposure, White Balance, Detail, Picture (Noise Reduction, E-Flip, ND Filter, IR Filter), Gamma, Lens (Focus, Stabilization), Pan & Tilt, Genlock, System (Pelco, Visca, IR, Baud Rate, Tally, Audio, Video Format) settings, and view System Status with Drop-Downs Menus, Buttons, and user-entry fields.

### Using the 12V Output Cable on the PTZ Camera

Follow these steps to enable the 12V output power on the user's PTZ camera:

- **Access the Live View Page:** The user needs to open the web GUI for their PTZ camera and navigate to the Live View page.
- **Open the Camera Settings:** The user should click on the Camera Settings tab located to the right of the Live View page.
- **Select 'System':** In the Camera Settings, the user needs to click on the 'System' option.
- **Enable 12V Output Power:** The user will see an option labeled 'DC 12V Out'. The user should click on the checkbox for 'ON' to enable the 12V output power.

### Settings - General

Under the General Settings page, there are three tabs: Dashboard, Output, and Genlock.

#### Dashboard

The Dashboard tab gives you a single page where you can view details of the camera such as temperature, power consumption, bandwidth utilization, firmware versions, and device serial number.

The screenshot shows the BOLIN PTZ Camera web interface. On the left is a navigation sidebar with 'Live view' and 'Settings' (with 'General' selected). The main content area is titled 'General' and has three tabs: 'Dashboard' (selected), 'Output', and 'Genlock'. The 'Dashboard' tab displays four panels: 'Protocol' (listing PELCO ID, VISCA ID, IR ID, BAUD RATE, and COMM-TYPE), 'Device' (listing Device Name, Model Number, and Serial Number), 'Firmware' (listing Firmware Version, MCU Version, FPGA Version, Web Plugins Version, and Hardware Version), and 'Status' (listing ARM Temperature, FPGA Temperature, Up Time, Power Consumption, Fan Speed, and Bandwidth).

| Protocol  |       |
|-----------|-------|
| PELCO ID  | 1     |
| VISCA ID  | 1     |
| IR ID     | 2     |
| BAUD RATE | 9600  |
| COMM-TYPE | RS422 |

| Device        |                      |
|---------------|----------------------|
| Device Name   | Bolin PTZ Camera     |
| Model Number  | XX-XXXX              |
| Serial Number | 00000000000000000000 |

| Firmware            |                   |
|---------------------|-------------------|
| Firmware Version    | 1.1.408           |
| MCU Version         | V0K010B35010ABT31 |
| FPGA Version        | P1D090300030FA050 |
| Web Plugins Version | 4.1.0.10541       |
| Hardware Version    | BA                |

| Status                    |   |
|---------------------------|---|
| ARM Temperature           | 83.4°F/66.2°C   |
| FPGA Temperature          | 82.0°F/64.8°C   |
| Up Time                   | 35 m  |
| Power Consumption (PoE++) | Min: 32W (Static state with no movement)<br>Max: 40W (Fully loaded operation) |
| Fan Speed                 | 0   |
| Bandwidth                 | TX: 13 Kbps<br>RX: 2 Kbps   |

#### Output

By selecting the "Output" tab on the General Settings page, users can define what resolutions/frame rates, color space, bit depth, and color format they would like the camera's physical ports to output. Users can click the parameter they would like to modify and select from the drop-down menu. Once the desired settings have

been chosen, click on the gray "Apply" button for changes to go into effect.

At the bottom of this tab, there is a section for "Output Status" where users can see the settings of what is being output from the device.

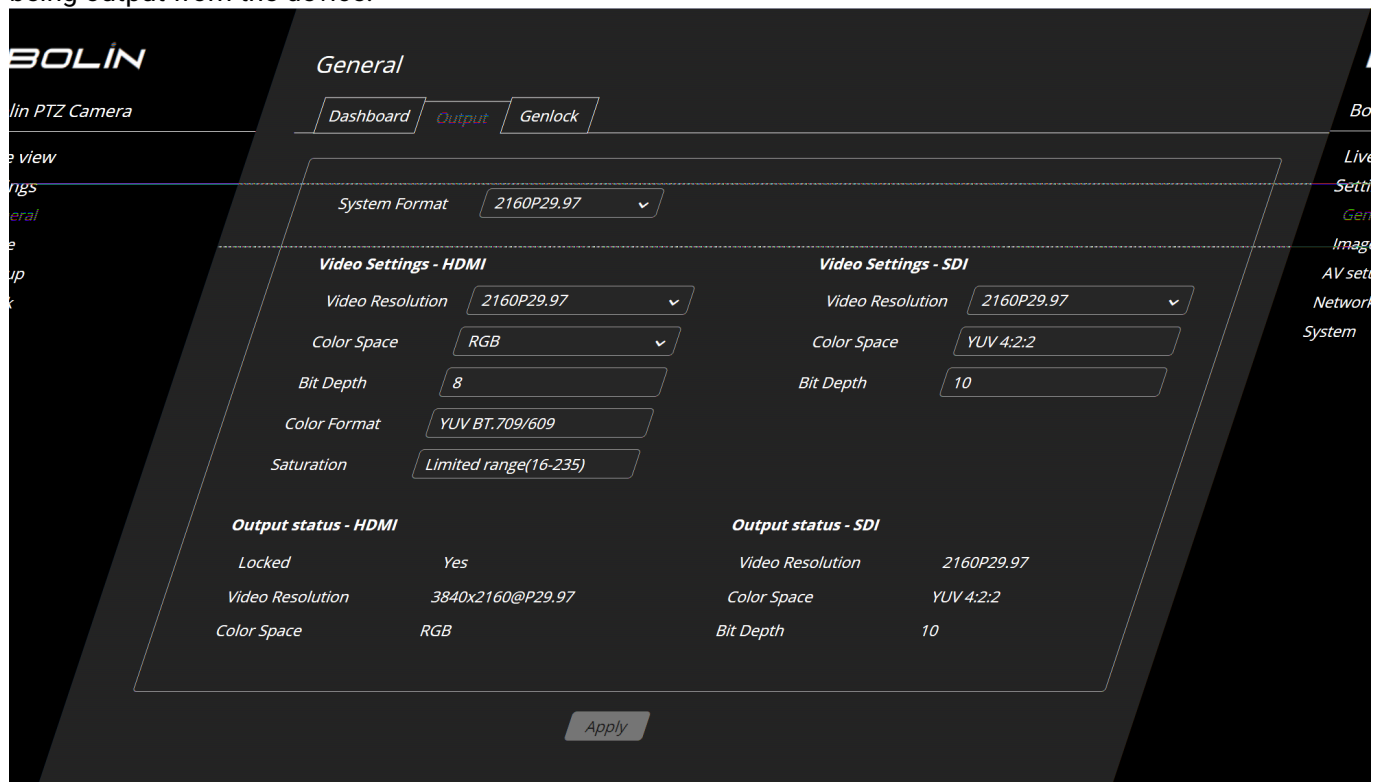

The "System Format" will set the highest resolution and frame rate for the camera. While the frame rates are the same, output resolutions are simultaneous and independent of each other. The HDMI, SDI/Optical Fiber, and IP outputs can be set to different resolutions without impacting each other. Optical Fiber output resolution is determined by the SDI resolution.

### Genlock

Genlock (generator locking) is a technique used to maintain synchronization.

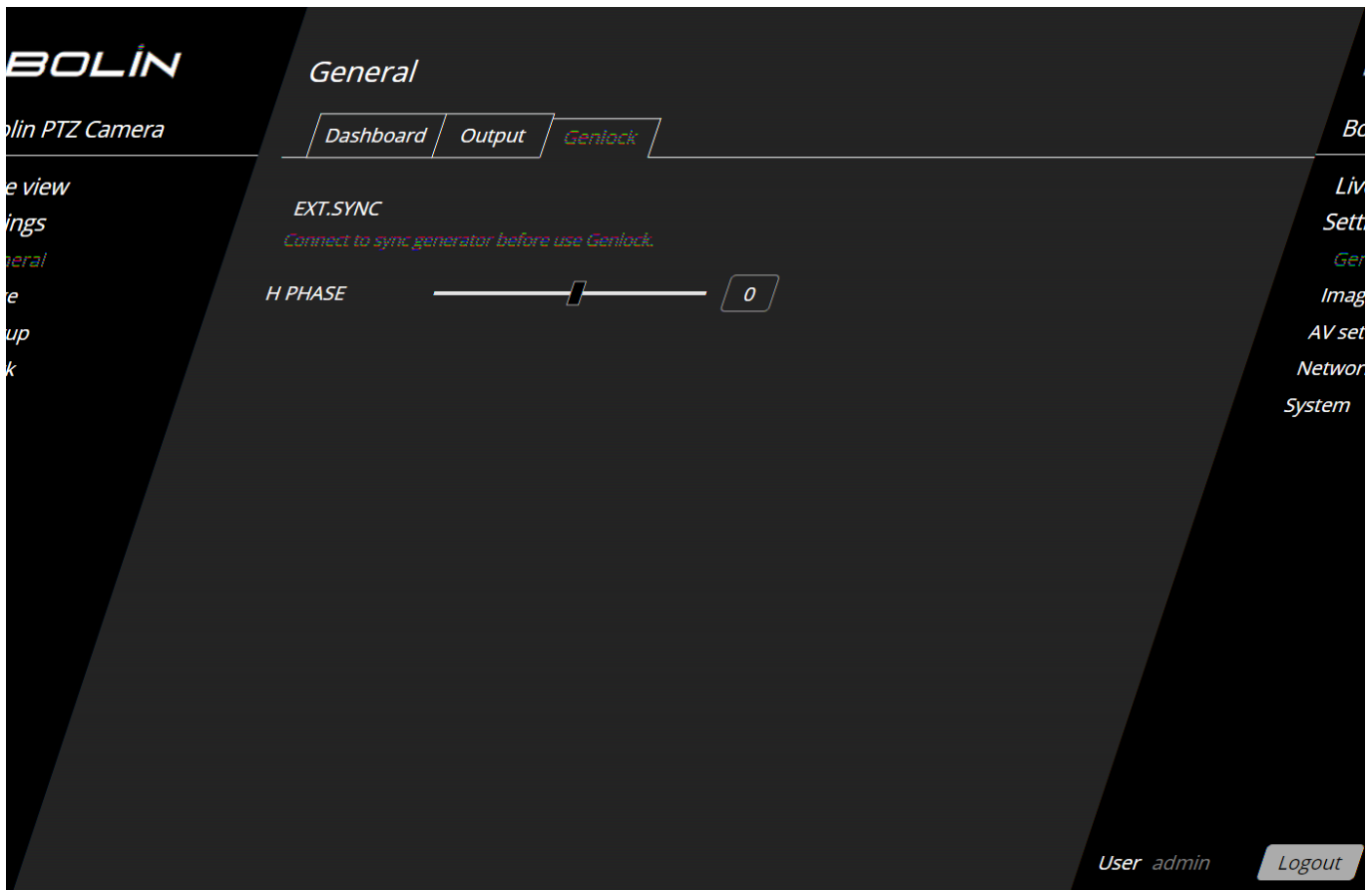

**H Phase fine:** is used for finely adjusting the horizontal phase during Genlock.

Note: A sync generator must be connected before the use of Genlock.

### Settings - Image

Under the Image Settings page, users can choose to control the camera's PTZ functions, add on-screen overlays, and create a privacy mask to hide sensitive content.

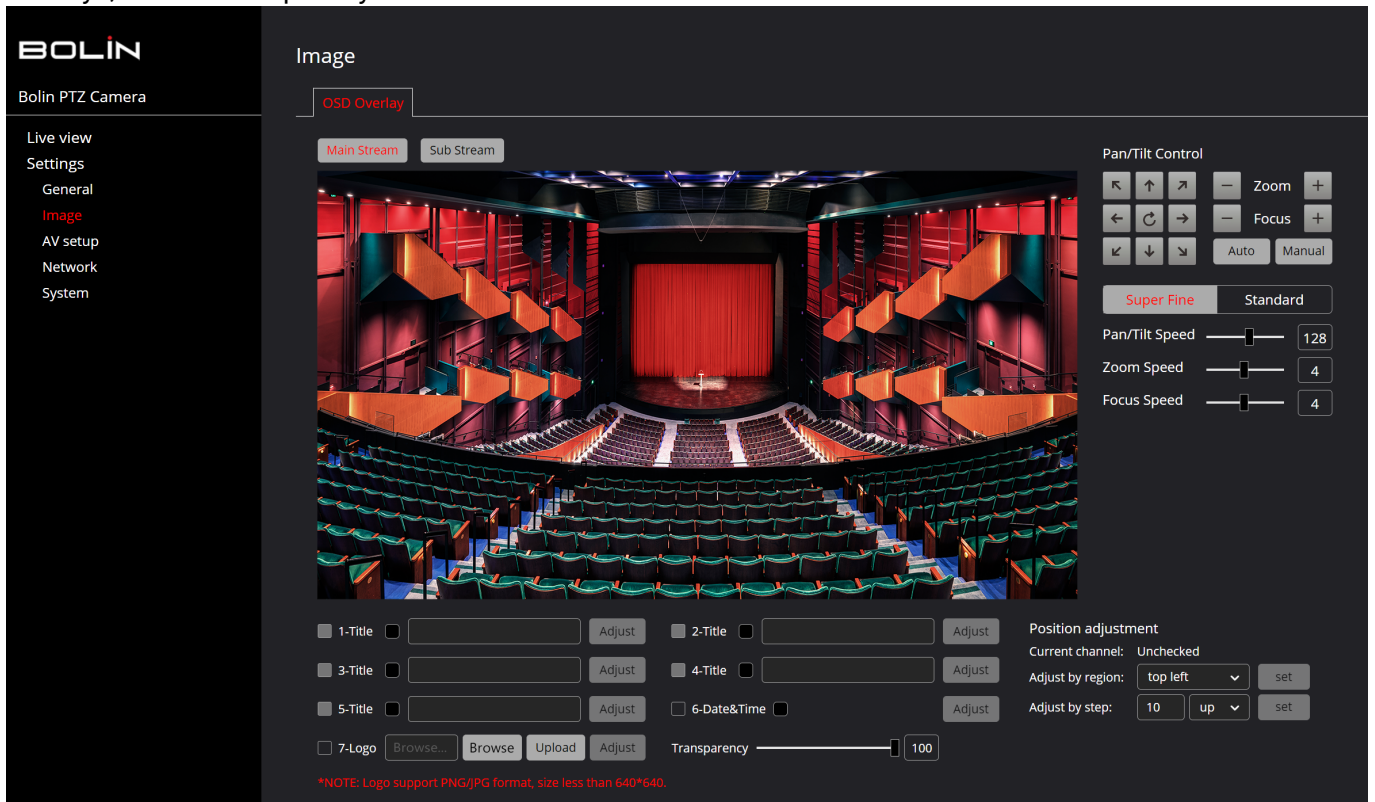

### OSD Overlays

The Bolin PTZ cameras feature an OSD overlay (on-screen character generator) function, which allows users

to embed important information (text or image) onto their IP video feed. To add an on-screen overlay, follow these steps:

1. Navigate to the "OSD Overlay" on the Image Settings page.
2. Select the type of overlay you need by clicking on the relevant checkbox and entering the information. Options include a title (customizable text), Date & Time, or Logo. Up to 32 characters per overlay are supported.
3. To adjust the overlay, click on the "Adjust" button next to the overlay you'd like to modify. Then use the "Position Adjustment" section to move the overlay to the desired position and use the "Transparency" slider to adjust accordingly.

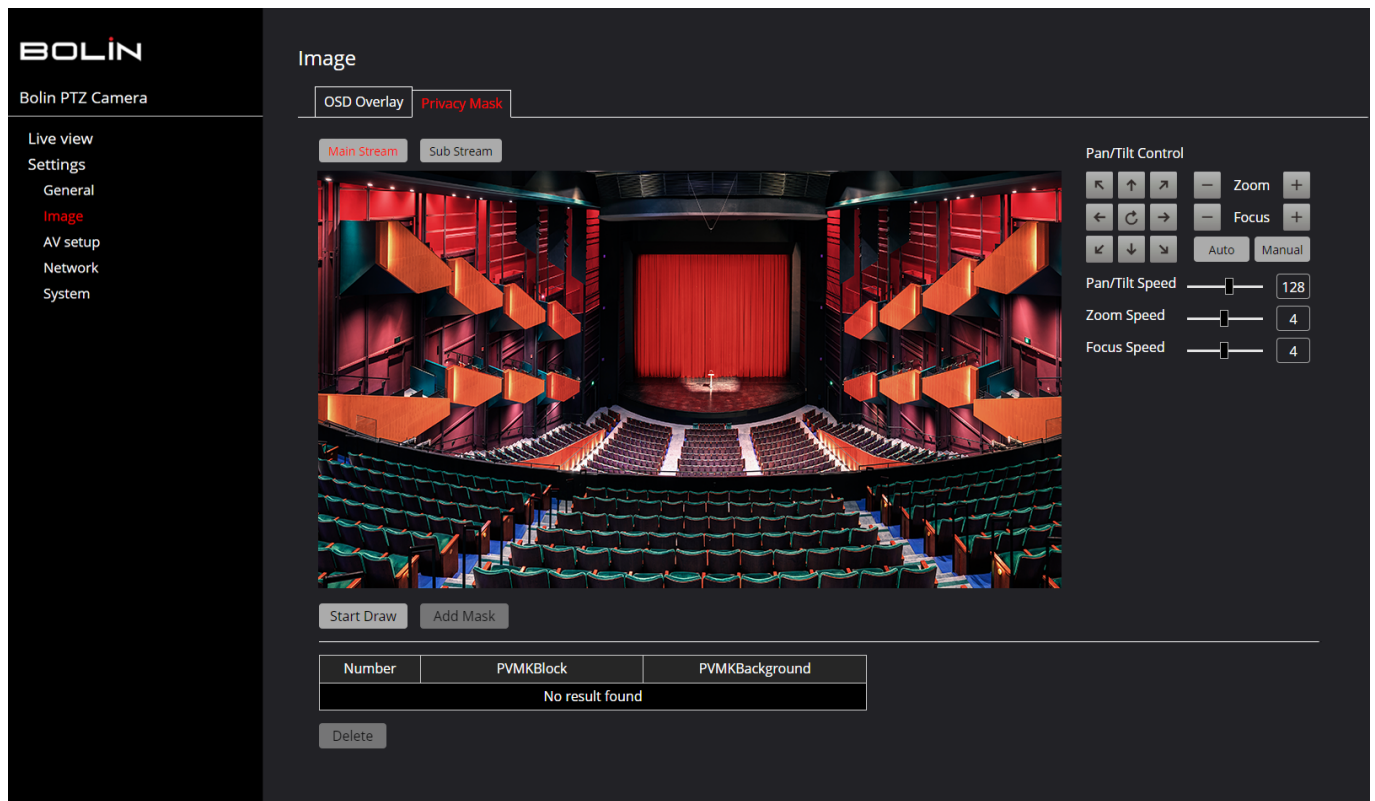

## Privacy Masks

In addition to text/graphic overlays to display info, the camera features a privacy mask function on the IP stream, which allows users to cover a certain portion of the screen to prevent confidential content from being seen. To create a privacy mask:

1. Navigate to the "Privacy Mask" tab on the Image Settings page. Make sure the camera is positioned where you would like to insert the privacy mask.
2. Click on the "Start Draw" button underneath the preview window. Draw the desired box(s) in the preview window by moving your mouse to the starting point and clicking to draw. Click on "Add Mask" once the desired box has been drawn. Up to 24 masks can be added. Once done, click on the "Stop Draw" button underneath the preview window.
3. To change the color of the masking box, navigate down to the list of masks and hover your mouse over the mask you'd like to change. Click on the drop-down menu button and select the desired color from the list of options (black, purple, red, green, blue, yellow, gray).
4. To delete a mask, select the mask from the list and press the "Delete" button at the bottom of the page. Confirm that you would like to delete the mask.

The mask will remain in the same position, even as the camera is moved. Please keep this in mind as you draw masks.

### Settings - AV Setup

Under the AV Setup page, users will be able to configure and enable IP streams, manage the video codec, and adjust audio settings.



### Streaming Server

From the Streaming Server tab, users can set up an IP stream to be sent from the camera to any destination via the network connection. This camera is capable of sending up to IP stream via RTSP, RTMP, SRT, MPEG-TS UDP, and MPEG-TS RTP.



To stream video from the camera to a destination, follow these steps:

1. Choose whether you want to stream the "Main Stream" or "Sub Stream" by selecting the appropriate stream type. Both streams contain the same video signal but can be configured with different codecs and resolutions under the Codec tab.
2. Enable the stream by toggling the button below the desired stream type. The stream has been turned on if the slider is red.
3. Click the "Edit" button that corresponds to the desired stream type. Enter the relevant details for the stream (Stream Key, URL, Stream Mode, Max Connections, etc...) Optionally, name the stream by its destination, title, or other desired name.
4. The Stream URL is displayed in red at the bottom of the RTSP and SRT stream settings. This link can be copied and pasted onto a video viewer, ingest server, etc... to access the stream anywhere on the network. By default, IP address is 192.168.0.13.
5. Streaming Server:
  1. **RTSP** Connection String: `rtsp://IP address:RTSP port/media/video<1/2>`  
RTSP port is **554**
  2. **SRT** Connection String: `srt://<IP address>:<SRT port>`



SRT port is **1000**

3. **RTMP Connection String: *RTMPstreamURL/Key***

RTMP Port is **1935**

Note: To stream video, the user must first log in to their video streaming platform. After logging in, they need to obtain the RTMP stream URL and key. Once they have these details, they can enter them into the RTMP settings page on the camera's IP web interface. This will configure the camera for streaming.

4. **MPEG-TS UDP Connection String: *udp://@<ipaddress>:<UDP port>***

MPEG-TS UDP port **6000**

5. **MPEG-TS RTP Connection String: *rtp://@<ipaddress>:<RTP port>***

MPEG-TS RTP port **6004**

6. To utilize the **Fast HEVC** feature on the camera, there are certain requirements that must be met:

1. Bolin Decoder (EG40F)
2. RTSP or SRT stream only.
3. Mainstream must be set to HEVC (H265).

### Codec

From the Codec tab, users can configure the video streams to meet their requirements. The various settings and their functions are described below.

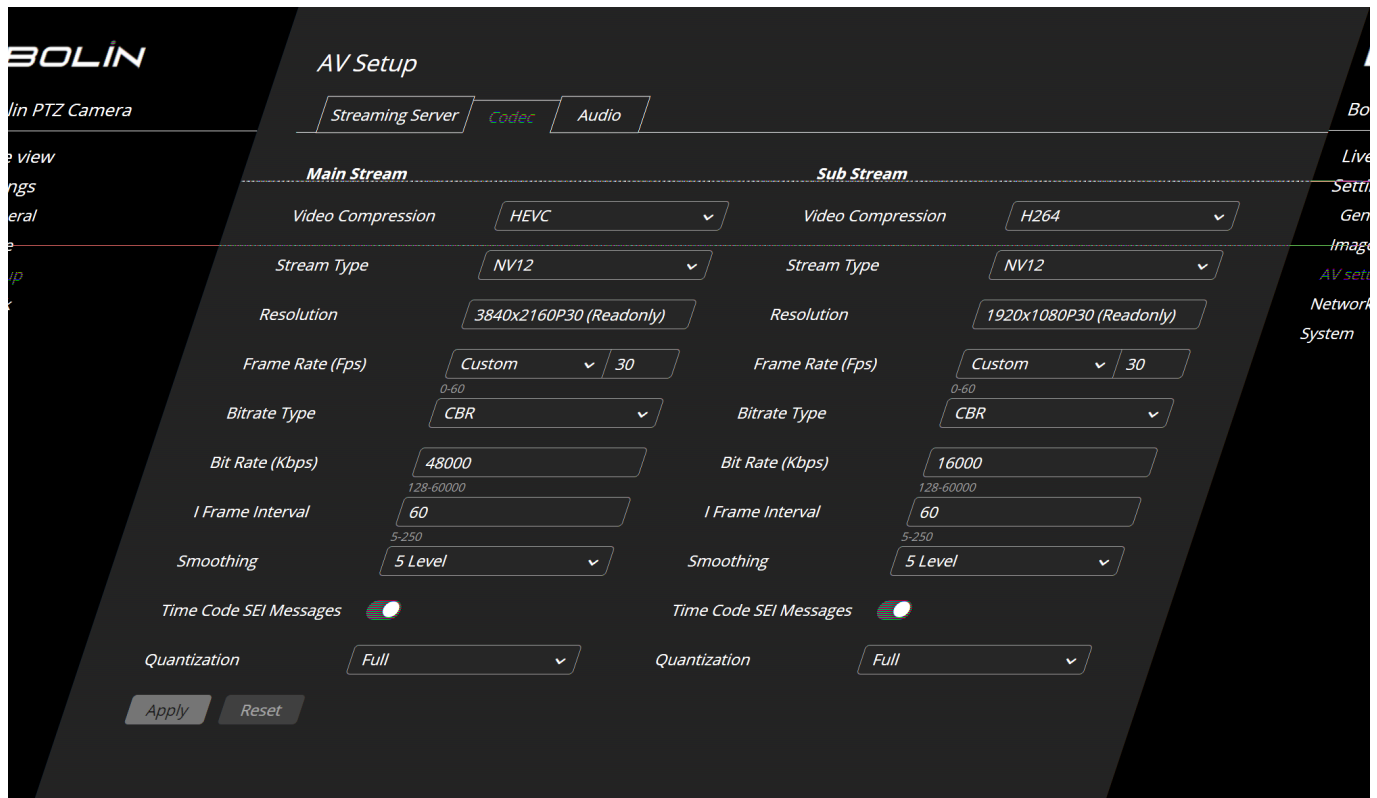

**Video Compression:** Options are H264 (AVC) or H265 (HEVC).

Video compression allows for the video signal to be streamed over the network while utilizing less space (data and bandwidth), while still maintaining a good-quality image. While this does cause some image degradation, compression only removes unwanted frames of video (determined by codec) and still maintains the necessary data and high quality required to stream.

Recommended: H.265 (HEVC)

|  |                    |                     |
|--|--------------------|---------------------|
|  | <b>H.264 (AVC)</b> | <b>H.265 (HEVC)</b> |
|--|--------------------|---------------------|

|                          |   |  |
|--------------------------|---|--|
| Minimum Bandwidth Needed | 720P - 3 Mbps<br>1080p - 6 Mbps<br>4K - 32 Mbps                         | 720P - 1.5 Mbps<br>1080p - 4 Mbps<br>4K - 15 Mbps  |
| Intraframe Prediction    | 9 Modes   | 35 Modes   |
| Color Depth              | 8-Bit   | 10-Bit   |
| Pros                     | Higher compatibility with devices<br>Uses less computing power          | More efficient codec, less bandwidth utilization<br>Near lossless encoding<br>Better motion prediction & compensation. |
| Cons                     | Uses more bandwidth<br>Doesn't support HDR & resolutions higher than 4K | Not as widely adopted; limited compatibility<br>Requires more powerful equipment for processing                        |

**Stream Type:** Options are NV12, NV16, XV15, XV20.

The stream type options determine what color format and bit-depth the video stream will be in. The options available are dependent on the video compression selected. If the compression is H.264, only NV12 & NV16 are available. If the compression is H.265, the video streams can be NV12, NV16, XV15, or XV20.

Recommended: NV16 or XV20

|             |           |           |           |           |
|-------------|-----------|-----------|-----------|-----------|
|             | NV12      | NV16      | XV15      | XV20      |
| Color Space | YUV 4:2:0 | YUV 4:2:2 | YUV 4:2:0 | YUV 4:2:2 |
| Bit Depth   | 8-Bit     | 8-Bit     | 10-Bit    | 10-Bit    |

**Frame Rate (Frames Per Second - FPS):** Options follow Input, Custom (0-60).

The frame rate is the number of frames (consecutive images) that are displayed in a video in a second to show movement. A higher frame rate will show smoother video and clearer images, while a lower frame rate means choppy motion and blurry footage. Traditionally, frame rates are 24FPS in film/movies, 25-30FPS on TV, and 30-60FPS for streaming video. When choosing frame rates, it is important to consider the bandwidth available on a network. Higher frame rates require higher bandwidth.

Recommended: Follow Input

**Bitrate Type & Bit Rate (Kbps):** CBR, VBR ; Custom.

Bitrate refers to the number of bits (data) that are encoded within a unit of time and is typically measured in Kbps (kilobits per second) or Mbps (megabits per second). Higher bitrate mean that more data is being encoded, which leads to a better-quality image, but encoding is dependent on the bandwidth and network speeds available. Even if the video signal being encoded is high resolution, the outgoing video may still be low resolution if the bitrate isn't high enough. On the flip side, if the bit rate is too high, it may cause buffering as there is too much data to be processed and not enough resources on a device.

There are two methods of encoding video: constant bitrate and variable bitrate. Constant bitrate encode data at a consistent rate throughout the stream, while variable bitrate change based on the bandwidth required to encode the data. While there are advantages to both, variable bitrate are recommended to more efficiently encode video streams.

Recommended Bitrate for Video Streaming

| Quality | Resolution | Bitrate          |
|---------|------------|------------------|
| 720P    | 1280x720   | 1200 - 4000 Kbps |
| 1080P   | 1920x1080  | 4000 - 8000 Kbps |

|    |           |                   |
|----|-----------|-------------------|
| 4K | 3840x2160 | 8000 - 14000 Kbps |
|----|-----------|-------------------|

**I Frame Interval:** Options are Custom (5-250).

Video streams consist of I-frames (Intra-frames) and P-frames (Predictive frames). I-frames capture the full image of everything the camera sees, while P-frames only capture elements of the image that are moving/changing. I-frames are followed by p-frames in a video stream. The reason for this is to compress the camera's bitrate and utilize less bandwidth. Rather than capturing/encoding a full image for every frame, the camera only needs to encode what has changed in one frame. A lower I-frame interval means a higher bitrate/bandwidth is needed to accommodate the number of full images being sent. This is recommended if a camera needs to refresh the image more often due to a scene with heavy motion.

It is recommended to set the I-frame interval to the same as the frame rate.

**Smoothing:** Options are Levels 1-6.

Smoothing reduces abrupt changes or fluctuations in video playback, commonly seen as visual jitter or abrupt transitions between frames. This aims to deliver a more consistent and visually pleasing viewing experience by minimizing disruptions caused by variations in network conditions or data transmission. Smoothing may add some buffer or frame interpolation to be achieved.

**Time Code SEI Messages:** Options ON, OFF.

In video streaming, supplemental enhancement information (SEI) is additional data, not related to audio/video, inserted into the bit stream to send extra information which is then received in synchronization with the audio and video data. Examples of this extra data include time codes, closed captioning, copyright information, etc... While standards are in place for how these SEI messages are encoded, there is no official requirement on how these are processed. If this setting is toggled off, the data will be discarded in the signal chain.

Recommended: Off

**Quantization:** Options are Full (0-255), Limited Range (16-235).

Quantization is a lossy compression technique where a determination is made about the amount of color data that will be encoded into a video stream. This is possible by compressing a range of color values into a single value, usually in a manner that is not discernable to the human eye. The quantization setting determines the amount of compression for all the macroblocks in a frame. Large values of quantization mean more compression, lower quality, and lower bandwidth, while lower values of quantization mean less compression, higher quality, and higher bandwidth being utilized.

By default, Bolin's cameras are set to "Limited Range".

Recommended: Limited Range

## **Audio**

From the Audio tab, users can configure the audio settings on the camera to meet their requirements. The various settings and their functions are described below.

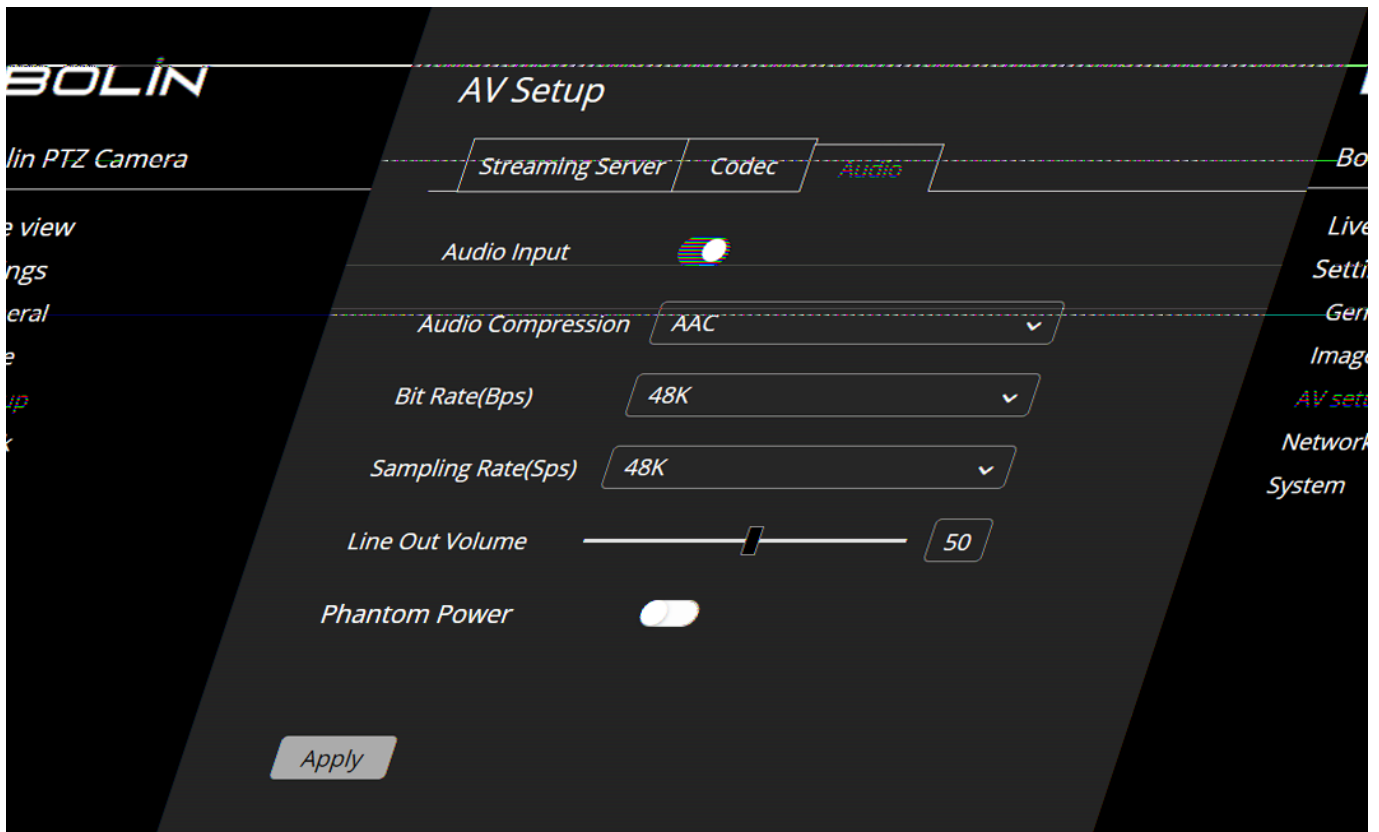

- **Audio Input:** Option to Mute audio.
- **Audio Compression:** Supports AAC, G.711a and G.711u.
- **Bit Rate(bps):** Supports 32K, 40K, 48K, 64K, 96K, and 128K.
- **Sampling Rate(sps):** Supports 16KHz, 32KHz, 44.1KHz, and 48KHz.
- **Line Out Volume:** Volume Control 0-50.
- **Phantom Power:** Phantom power is a method that provides DC electric power at 48 volts, to sensitive microphones through an XLR cable, eliminating the need for an external power supply or battery.

**CAUTION:** Please verify that the microphone in use specifically requires 48v of power.

## Settings - Network

### Common

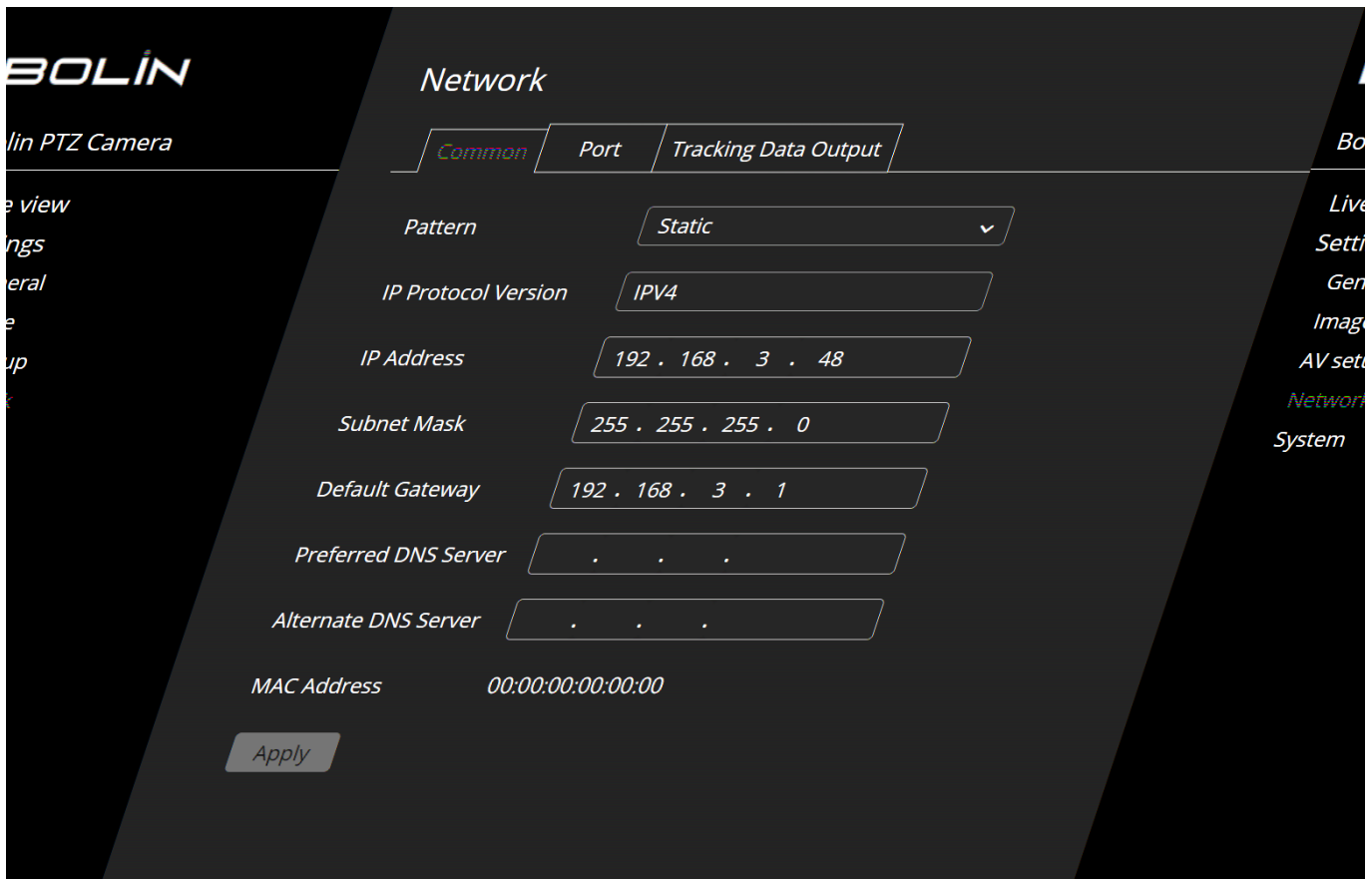

- **Pattern:** Static and DHCP

- DHCP - The IP Address of the device will be determined and dynamically assigned from the network gateway (router). This is recommended when the device is being installed on a network where the available IPs are unknown and a quick setup is required.
- Static IP- The user will define and enter the IP address of the device. It is recommended to put the device on a known, constant IP address and guarantee the device will retain its IP address after a reboot or power failure. If not sure what IP addresses are available on a network, a user can set the camera to DHCP and use the assigned address as a static IP.

 **NOTE:** Static IP is recommended. By default, the camera is set to a Static IP Address of 192.168.0.13.

- **Subnet Mask:** A subnet mask is a filter for IP addresses, helping to organize and divide a large network into smaller groups, so devices within each group can communicate more efficiently.

 **NOTE:** By default, the camera is set to a subnet mask of 255.255.255.0.

- **Default Gateway:** When configuring the device, the default gateway IP address should be set to the IP address of the router that serves as the gateway for the local network. This address allows the device to communicate with destinations outside its immediate network.

 **NOTE:** By default, the gateway is set to 192.168.0.1.

- **Preferred DNS Server:** DNS (Domain Name System) servers are the addresses specified on a device for translating domain names into IP addresses. The preferred DNS server is the primary server used for this translation, and the alternate DNS server serves as a backup in case the preferred server is unavailable or experiences issues, ensuring access to the internet and other network resources.
  - On a network that is not connected to the Internet, this can be left blank.
- **Alternate DNS Server:** allows the user to specify a secondary DNS (Domain Name System) server. This server is used for resolving domain names to IP addresses in case the primary DNS server is unavailable or cannot be reached.
- **MAC Address:** This is a fixed address, used as a unique identifier of the device on a network. This cannot be changed.

## Port

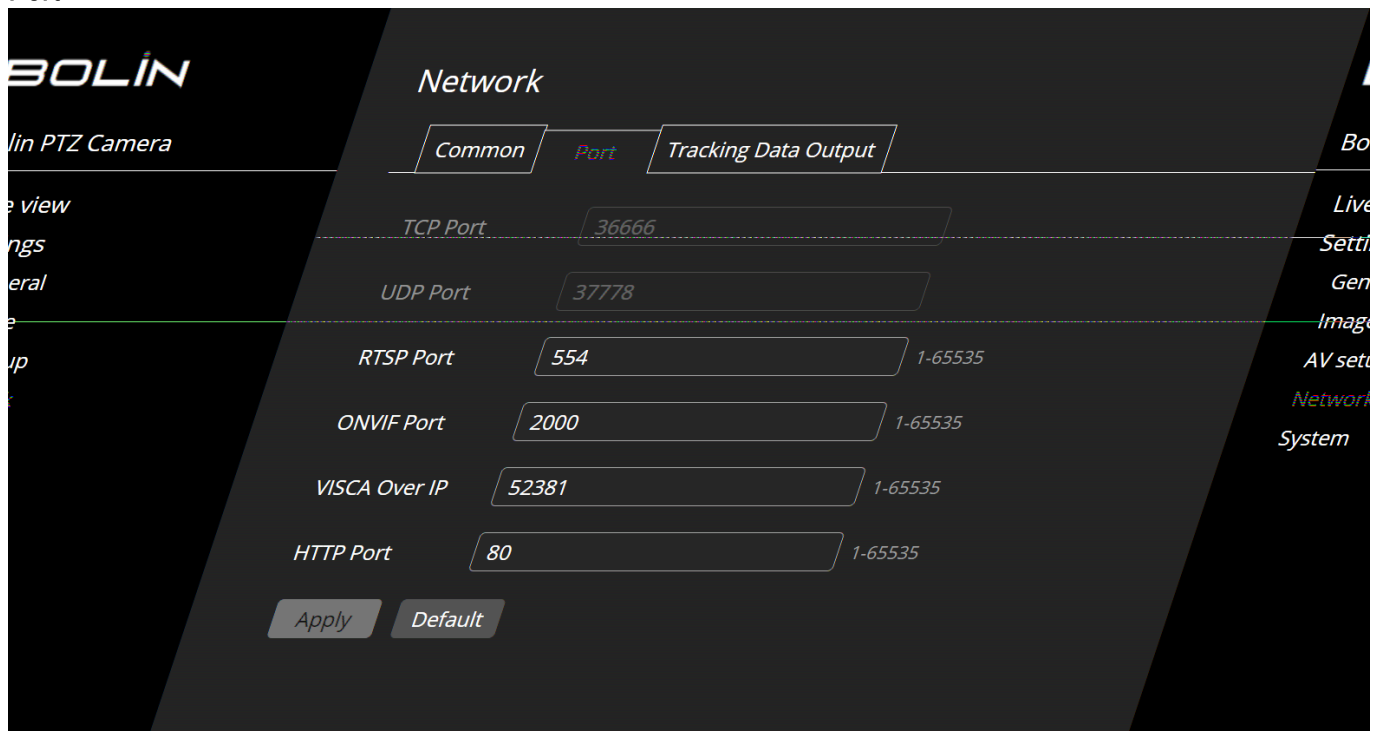

- **TCP Port:** TCP (Transmission Control Protocol) is a reliable, connection-oriented protocol used to ensure the secure and ordered delivery of data. TCP guarantees that transmitted video frames are received without loss and in the correct order, making it suitable for applications where data integrity is crucial, even though it may introduce slightly higher latency.

 **NOTE:** This port is predetermined as port 36666 and cannot be modified.

- **UDP Port:** UDP (User Datagram Protocol) is a connectionless protocol that provides low-latency transmission but without guaranteed delivery or order of data, which may lead to occasional data loss in exchange for faster performance. In IP camera applications, this can result in brief interruptions or quality degradation during live monitoring.

 **NOTE:** This port is predetermined as port 37778 and cannot be modified.

- **RTSP Port:** RTSP (Real-Time Streaming Protocol) is a network control protocol used for the delivery of real-time streaming media. The RTSP port is the network port designated for RTSP communication, allowing devices like IP cameras to send and receive streaming commands and data for effective real-time video transmission and control.

 **NOTE:** Commonly, RTSP uses port 554, but the specific port can be configured between 1-65535 based on system requirements.

- **ONVIF Port:** ONVIF (Open Network Video Interface Forum) is a standard that facilitates interoperability between different IP-based video devices, including cameras and video management systems. The ONVIF port is the network port designated for communication using the ONVIF protocol, enabling devices to exchange information and ensure compatibility within a networked video surveillance system.

 **NOTE:** By default, ONVIF uses port 2000, but the specific port can be configured between 1-65535 based on system requirements.

- **VISCA Over IP:** VISCA over IP is the implementation of the VISCA (Video System Control Architecture) protocol, commonly used for camera control, over an IP network. The VISCA over IP port is the specific network port through which devices communicate using the VISCA protocol, allowing for remote control and coordination of functionalities in compatible cameras.

 **NOTE:** By default, VISCA over IP uses port 52381 for communication. This is the standard used by Bolin's PTZ controllers as well. The port number can be configured between 1-65535 to match with third-party controllers.

- **HTTP Port:** HTTP (Hypertext Transfer Protocol) is the protocol for data communication on the network, used for the transfer of text, images, sound, video, and other files between web browsers and servers. The HTTP port is the specific network port through which devices establish connections for communication, facilitating the exchange of information between clients (such as web browsers) and servers on a local network or the Internet.

 **NOTE:** By default, HTTP uses port 80, but the specific port can be configured between 1-65535 based on system requirements.

## Tracking Data Output

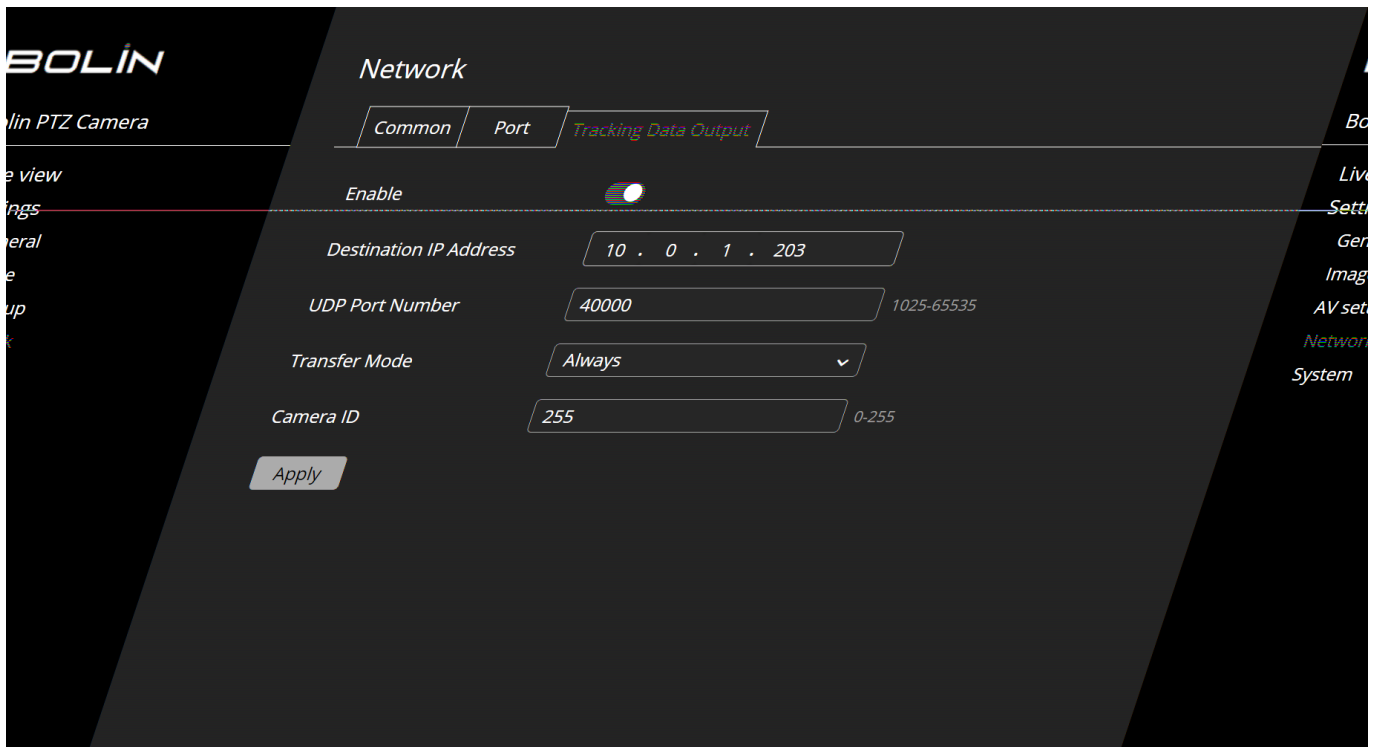

- 1. Enable:** This parameter acts as the primary control for the PTZF tracking metadata transmission. You can turn the tracking data output on or off using this setting. When enabled, the system will transmit tracking metadata; when disabled, the transmission will be halted.
- 2. Destination IP Address:** This parameter refers to the IP address of the device (usually a PC) that is set to receive the FreeD protocol. It should match the IP address of your tracking system device. This parameter specifies the remote address of the FreeD client that is intended to receive the metadata stream. Please note, that this parameter is only utilized when in “always” mode.
- 3. UDP Port Number:** This parameter represents the remote UDP port number associated with the FreeD client. It is used to establish the connection for data transmission.
- 4. Transfer Mode:** This parameter allows you to choose the stream mode for sending FreeD data. Currently, we only support the “Always” mode.
- 5. Camera ID:** This parameter is used to designate the Camera ID value. This value is inserted into the first byte (<CA>) of the FreeD D0 message. It uniquely identifies the camera in the FreeD protocol.

|                 |                                     |  |
|-----------------|-------------------------------------|--|
| FreeD Camera ID | Up to 0-255<br>Default value: "255" | Specifies FreeD Camera ID (<CA>) in decimal form |
|-----------------|-------------------------------------|--|

Settings - System



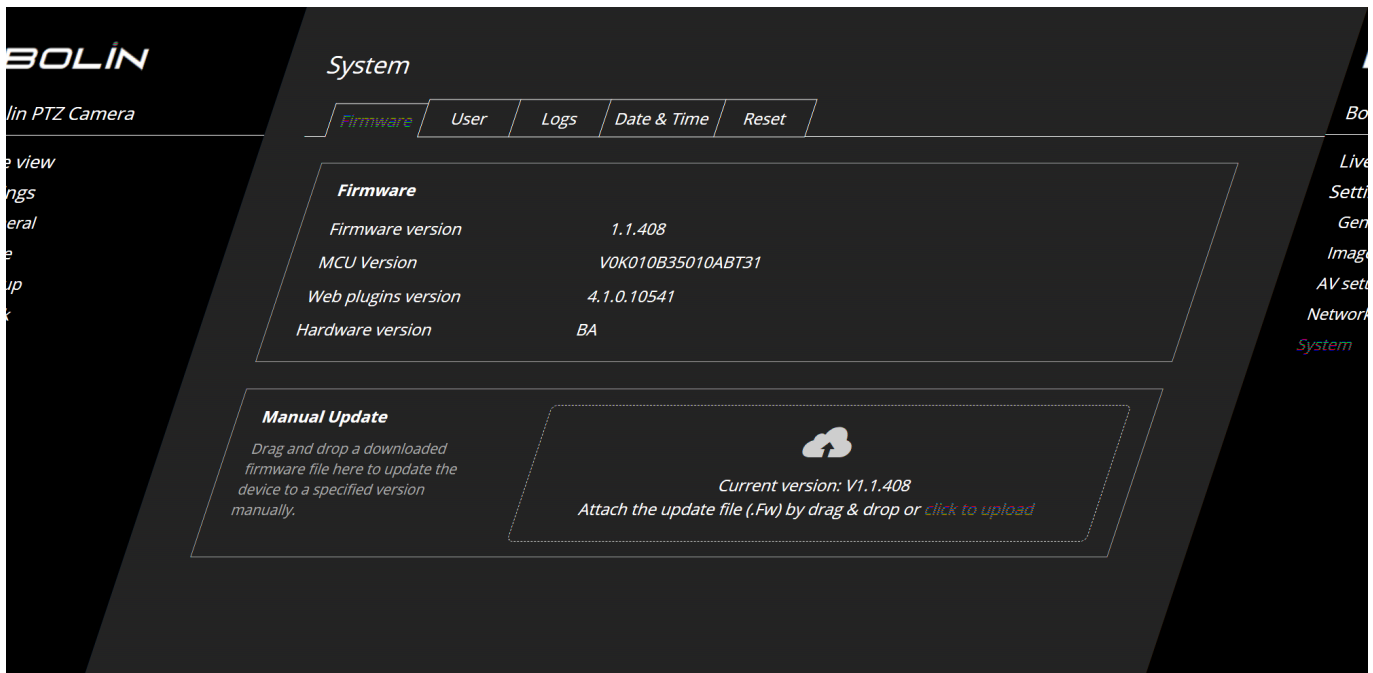

## Firmware

There are two parts to the Firmware tab. The upper part identifies the firmware version that the device is currently running. The lower part is where users can upload a new firmware file to update the device firmware.

To update the firmware, follow these steps:

1. Visit Bolin Technology's official website at [www.BolinTechnology.com](http://www.BolinTechnology.com).
2. Navigate to the "Support Center" and select the "Download Center" option.
3. Input the model number of the device and select the corresponding device from the list.
4. Download the firmware file and save it to a location on the computer.
5. Access the web interface of the device. The downloaded firmware file can be dragged and dropped into the designated box or the box can be clicked to manually select the file for upload.
6. After the device has verified the validity of the file, initiate the update process by clicking on the red "Update" button. During the update process, refrain from navigating away from the current tab, page, or window, and avoid clicking elsewhere on the page to prevent the update from failing.
7. Upon successful installation of the update, a prompt will appear instructing to restart the device. Follow this prompt to complete the update process.



**NOTE:** It is crucial to maintain the current page active during the update process to ensure a successful update. Any navigation away from the page could result in a failed update.

## User

The User tab, found under the System section, is where operators who have access to the camera can be managed. It should be noted that operators do not possess the same level of access to system settings as administrators.

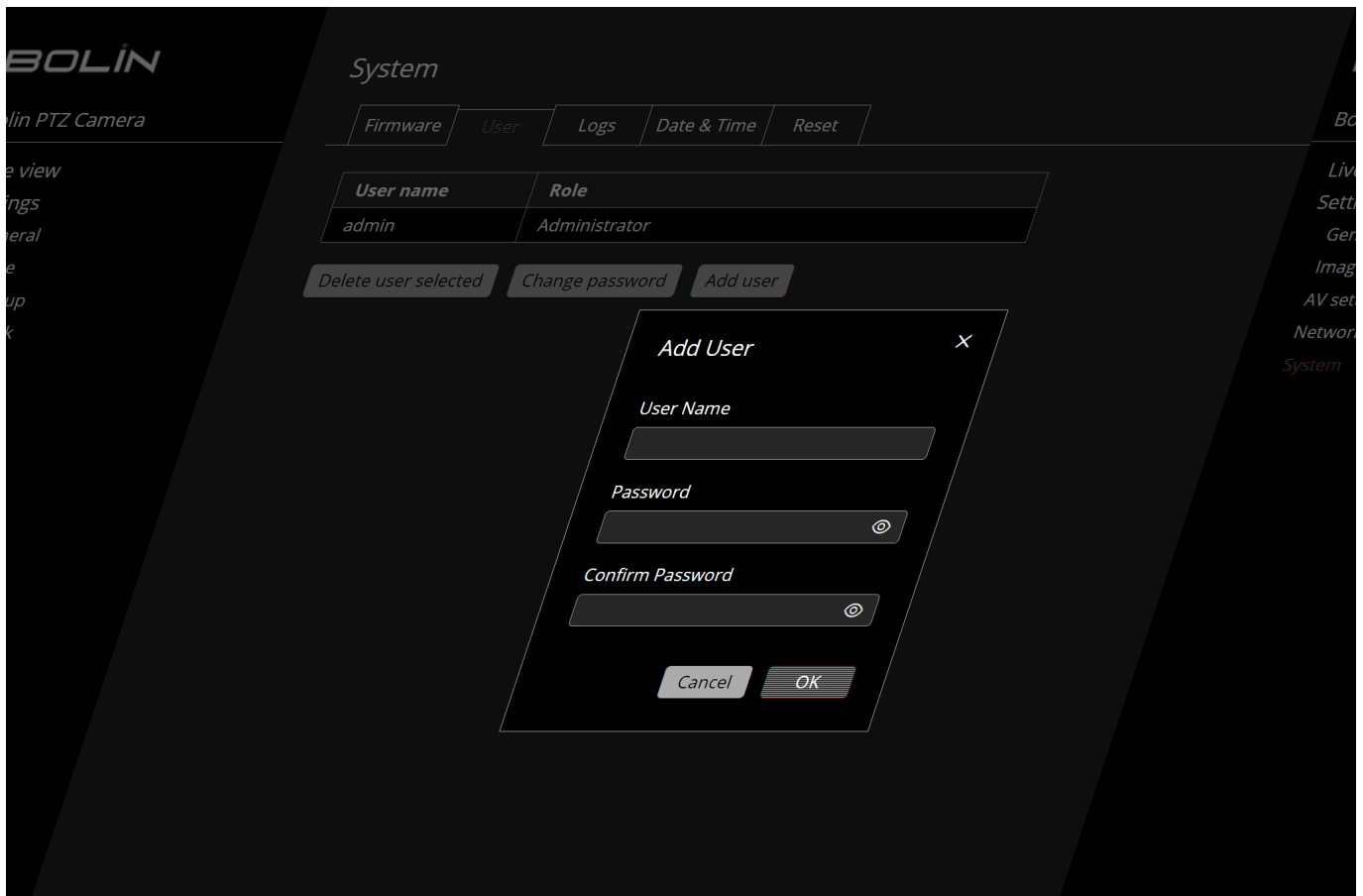

To add a new operator, follow these steps:

1. Under the System section, find the User tab.
2. Click on the 'Add User' button.
3. In the new window that appears, enter a username that is between 3–12 characters long, and a password. As you type the password, you can click on the eye icon to preview it. It's recommended to use a strong password that includes a capital letter, a lowercase letter, a number, and a special character.
4. Once you've confirmed the password, click on 'OK' to save the new operator. You can add up to 12 additional operators.

 **Note:** Only administrators can delete users.

## Logs

Under the "Logs" tab, users can see the actions that are performed by the device. The log can be filtered by All, Information, Warnings, and Errors. At the bottom of the page, there are options to clear the log or export the data as an HTML file.

Total : 2705 events

All  Information  Warning  Error

Track important events generated by the device and export them as a file for technical support.

| Level | No.    | Date & Time             | Details  |
|-------|--------|-------------------------|--|
| ⓘ     | 404280 | 2020/05/04 16:32:31.319 | User 'admin' (192.168.3.22) logged in                                  |
| ⓘ     | 404279 | 2020/05/04 16:15:04.843 | User 'admin' (192.168.3.22) logged out                                 |
| ⓘ     | 404278 | 2020/05/04 15:23:46.420 | User 'admin' (192.168.3.22) logged in                                  |
| ⓘ     | 404277 | 2020/05/04 15:23:05.547 | [mw_onvif_server.cpp:862] ONVIF thread begin                           |
| ⓘ     | 404276 | 2020/05/04 15:23:05.547 | [mw_onvif_server.cpp:794] WSDD thread begin                            |
| ⓘ     | 404275 | 2020/05/04 15:23:05.547 | Startup ONVIF port 2000  |
| ⊗     | 404274 | 2020/05/04 15:23:05.545 | [mw_onvif_server.cpp:319] profile substream not exist                  |
| ⊗     | 404273 | 2020/05/04 15:23:05.545 | [mw_onvif_server.cpp:319] profile mainstream not exist                 |
| ⓘ     | 404272 | 2020/05/04 15:23:04.544 | Interface (eth0) was assigned IP address 192.168.3.48                  |
| ⓘ     | 404271 | 2020/05/04 15:23:04.338 | Bolin carrierboard startup: version(0.1.776) hash(d3733a4), Success(0) |
| ⓘ     | 404270 | 2020/05/04 15:23:03.241 | Bolin board started!   |
| ⓘ     | 404269 | 2020/05/04 15:23:01.373 | devd started   |
| ⓘ     | 404268 | 2020/05/04 15:23:01.008 | Hardware clock set to system clock                                     |
| ⓘ     | 404267 | 2020/05/01 13:15:07.980 | Deleted user '123'   |
| ⓘ     | 404266 | 2020/05/01 13:10:51.721 | Added user '123'   |
| ⓘ     | 404265 | 2020/05/01 12:32:19.999 | Deleted user 'lily'  |
| ⓘ     | 404264 | 2020/05/01 12:32:06.931 | User 'admin' (192.168.3.22) logged in                                  |
| ⓘ     | 404263 | 2020/05/01 12:28:58.537 | [mw_onvif_server.cpp:862] ONVIF thread begin                           |
| ⓘ     | 404262 | 2020/05/01 12:28:58.536 | [mw_onvif_server.cpp:794] WSDD thread begin                            |
| ⓘ     | 404261 | 2020/05/01 12:28:58.536 | Startup ONVIF port 2000  |
| ⊗     | 404260 | 2020/05/01 12:28:58.534 | [mw_onvif_server.cpp:319] profile substream not exist                  |
| ⊗     | 404259 | 2020/05/01 12:28:58.534 | [mw_onvif_server.cpp:319] profile mainstream not exist                 |

Clear Export... Report

User admin

Logout

### Date & Time

Under the "Date & Time" tab, users can configure the date and time settings of the camera.

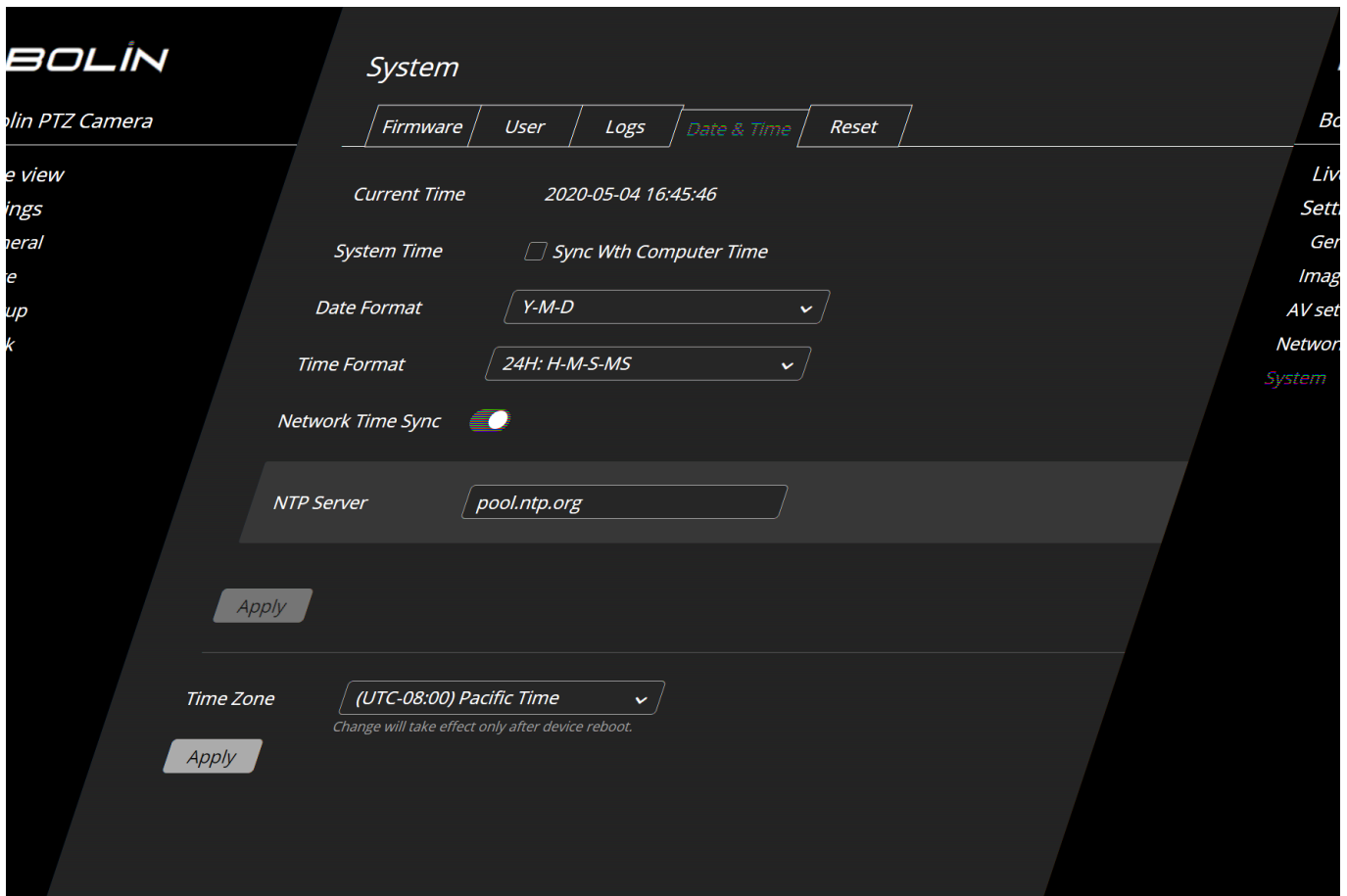

- **Current Time:** Displays devices' current date & time.
- **System Time:** Check the box to sync the device with the date and time that your computer is currently set to.
- **Date Format:** Users have the option to set the date format as either Y-M-D or D-M-Y.
- **Time Format:** Users have the option to set the time as either a 12- or 24-hour clock and whether it is displayed with or without milliseconds. (4 Options - 24H: H-M-S; 24H: H-M-S-MS; 12H: H-M-S; 12H H-M-S-MS)
- **Network Time Sync:** Check this box to have the camera synced with an NTP (Network Time Protocol) Server. If using this option, enter the URL of an NTP server in the highlighted field.

### Reset

In the "Reset" section, you have the option to either restart the camera or restore the camera to its original factory settings.

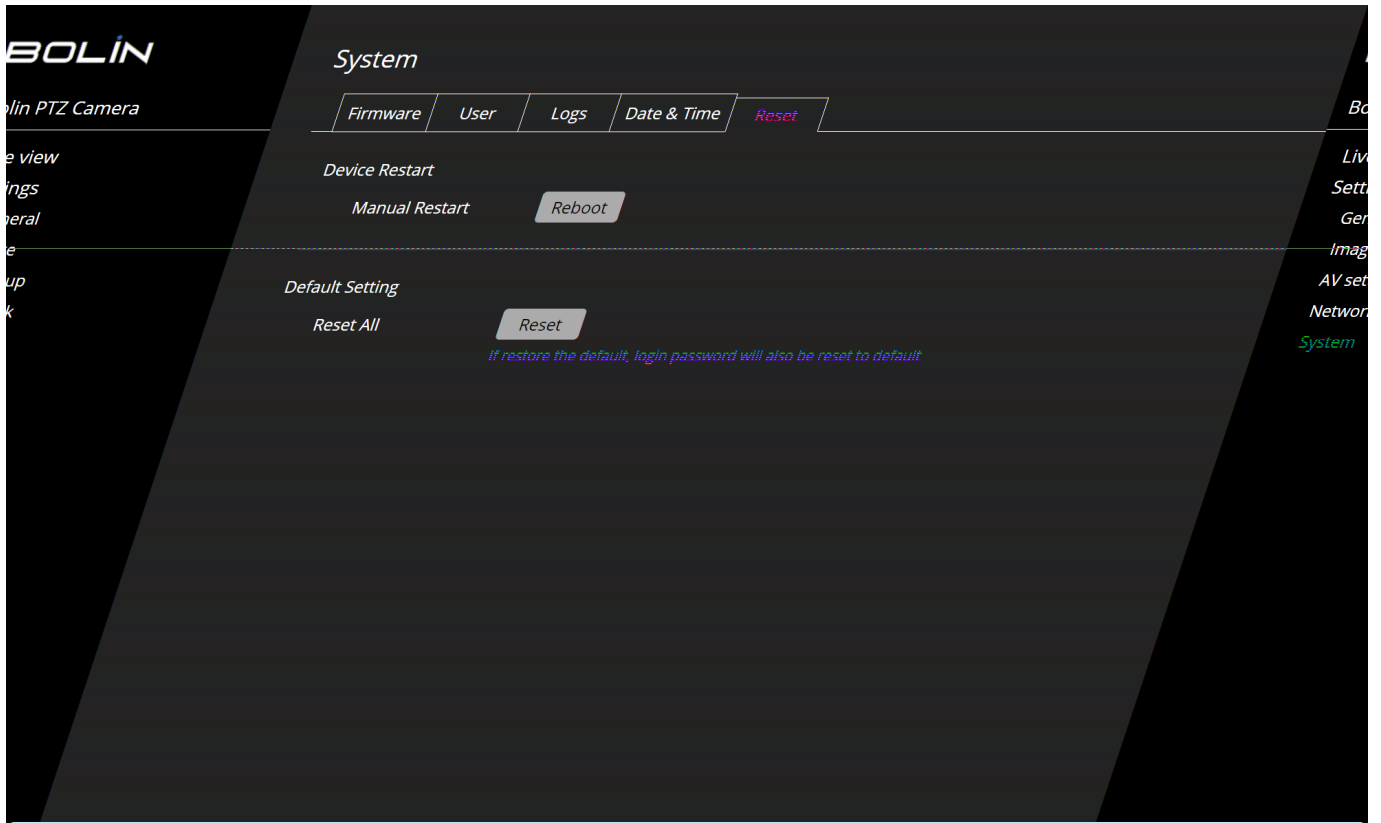

 **NOTE:** It should be noted that restoring to factory default will also erase the network and login configurations. This action will return all settings to their original state.

# System Menus

## EXU-248F OSD Menu Structure

|                     |   |                        |  |  |
|---------------------|---|------------------------|--|--|
| Exposure            | Mode: Full Auto   | High Sensitivity       | Off, On  |  |
|                     |   | Slow Shutter           | Off, On  |  |
|                     |   | S. Shutter Limit       | 1/1 - 1/50   |  |
|                     |   | Gain Limit             | 9DB, 12DB, 15DB, 18DB, 21DB, 24DB, 27DB, 30DB, 33DB, 36DB, 39DB, 42DB, 45DB, 48DB  |  |
|                     |   | Gain Point             | Off, On  |  |
|                     |   | Point Position         | 0DB, 3DB, 6DB, 9DB, 12DB, 15DB, 18DB, 21DB, 24DB, 27DB, 30DB, 33DB, 36DB   |  |
|                     |   | Max. Speed             | 1/100 - 1/10K (1/100 level determined by the Min. Speed setting)   |  |
|                     |   | Min. Speed             | 1/25, 1/30-1/10K (1/10K level is determined by the Max Speed setting)  |  |
|                     |   | Backlight              | Off, On  |  |
|                     |   | Spotlight              | Off, On  |  |
|                     |   | AE Speed               | 1-48   |  |
|                     |   | Ex. Comp               | Off, On  |  |
|                     |   | Ex. Comp Level         | -10.5, -9, -7.5, -6, -4.5, -3, -1.5, 0, +1.5, +3, +4.5, +6, +7.5, +9, +10.5  |  |
|                     |   | Mode: Manual           | High Sensitivity   | Off, On  |
|                     |   | Gain                   | 0DB, 3dB, 6dB, 9DB, 12DB, 15DB, 18DB, 21DB, 24DB, 27DB, 30DB, 33DB, 36DB, 39DB, 42DB, 45DB, 48DB   |  |
|                     |   | Speed                  | 50P, 25P, 50I- 1/1 2/3 1/2 1/3 1/4 1/6 1/8 1/12 1/15 1/20 1/25 1/30 1/50 1/60 1/100 1/120 1/150, 1/215, 1/300 1/425 1/600 1/1000 1/1250 1/1750 1/2500 1/2500 1/3500 1/6000 1/6000 1/10K<br>30P, 59.94I, 29.97P, 59.94P 60I, 60P -<br>1/1 2/3 1/2 1/3 1/4 1/6 1/8 1/10 1/15 1/20 1/30 1/50 1/60 1/90 1/100 1/125 1/180 1/250 1/350 1/500 1/725 1/725 1/1000 1/1500 1/2000 1/3000 1/4000 1/6000 1/6000 1/10K |  |
|                     |   | Iris                   | F2.8 F3.1 F3.4 F3.7 F4.0 F4.4 F4.8 F5.2 F5.6 F6.2 F6.8 F7.3 F8.0 F9.6 F10 F11  |  |
|                     |   | Mode: Iris Priority    | Iris   | F2.8 F3.1 F3.4 F3.7 F4.0 F4.4 F4.8 F5.2 F5.6 F6.2 F6.8 F7.3 F8.0 F9.6 F10 F11  |
|                     |   | Gain Limit             | 9DB 12DB 15DB 18DB 21DB 24DB 27DB 30DB 33DB 36DB 39DB 42DB 45DB 48DB   |  |
|                     |   | Gain Point             | Off, On  |  |
|                     |   | Point Position         | 0DB 3DB 6DB 9DB 12DB 15DB 18DB 21DB 24DB 27DB 30DB 33DB 36DB   |  |
|                     |   | Max Shutter            | 1/100 - 1/10K (1/100 level determined by the Min. Speed setting)   |  |
|                     |   | Min Shutter            | 1/25, 1/30-1/10K (1/10K level is determined by the Max Speed setting)  |  |
|                     |   | Backlight              | Off, On  |  |
|                     |   | Spotlight              | Off, On  |  |
|                     |   | AE Speed               | 01-48  |  |
|                     |   | Ex-Comp                | Off, On  |  |
|                     |   | Ex-Comp Level          | -10.5 -9 -7.5 -6 -4.5 -3 -1.5 0 +1.5 +3 +4.5 +6 +7.5 +9 +10.5  |  |
|                     |   | Mode: Shutter Priority | Speed  | 50P, 25P, 50I- 1/1 2/3 1/2 1/3 1/4 1/6 1/8 1/12 1/15 1/20 1/25 1/30 1/50 1/60 1/100 1/120 1/150, 1/215, 1/300 1/425 1/600 1/1000 1/1250 1/1750 1/2500 1/2500 1/3500 1/6000 1/6000 1/10K<br>30P, 59.94I, 29.97P, 59.94P 60I, 60P -<br>1/1 2/3 1/2 1/3 1/4 1/6 1/8 1/10 1/15 1/20 1/30 1/50 1/60 1/90 1/100 1/125 1/180 1/250 1/350 1/500 1/725 1/725 1/1000 1/1500 1/2000 1/3000 1/4000 1/6000 1/6000 1/10K |
|                     |   | Gain Limit             | 9DB 12DB 15DB 18DB 21DB 24DB 27DB 30DB 33DB 36DB 39DB 42DB 45DB 48DB   |  |
| Backlight           | Off, On   |                        |  |  |
| Spotlight           | Off, On   |                        |  |  |
| AE Speed            | 01-48   |                        |  |  |
| Ex-Comp             | Off, On   |                        |  |  |
| Ex-Comp Level       | -10.5 -9 -7.5 -6 -4.5 -3 -1.5 0 +1.5 +3 +4.5 +6 +7.5 +9 +10.5 |                        |  |  |
| Mode: Bright        |   | High Sensitivity       | Off, On  |  |
|                     |   | Level                  | 05-37  |  |
| Mode: Gain Priority |   | High Sensitivity       | Off, On  |  |
|                     |   | Gain                   | 0dB 3dB 6dB 9DB 12DB 15DB 18DB 21DB 24DB 27DB 30DB 33DB 36DB 39DB 42DB 45DB 48DB   |  |
|                     |   | Gain Point             | Off, On  |  |
|                     |   | Point Position         | 0DB 3DB 6DB 9DB 12DB 15DB 18DB 21DB 24DB 27DB 30DB 33DB 36DB   |  |
|                     |   | Max Speed              | 1/100 - 1/10K (1/100 level determined by the Min. Speed setting)   |  |
|                     |   | Min Speed              | 1/25, 1/30-1/10K (1/10K level is determined by the Max Speed setting)  |  |
|                     |   | Backlight              | Off, On  |  |
|                     |   | Spotlight              | Off, On  |  |
|                     |   | AE Speed               | 01-46  |  |
|                     |   | Ex-Comp                | Off, On  |  |
| Ex-Comp Level       | -10.5 -9 -7.5 -6 -4.5 -3 -1.5 0 +1.5 +3 +4.5 +6 +7.5 +9 +10.5 |                        |  |  |
| White Balance       | Mode: Auto  | Speed                  | 01 - 05  |  |
|                     |   | Offset                 | -7 - +7  |  |
|                     |   | Matrix                 | Off, On  |  |
|                     |   | Select                 | Standard, Fl. Light, High Saturation   |  |
|                     |   | Level                  | 0 - 14   |  |

|  |                    |        |                                      |
|--|--------------------|--------|--------------------------------------|
|  |                    | Phase  | -7 - +7                              |
|  |                    | R-G    | -99 - 0 - +99                        |
|  |                    | R-B    | -99 - 0 - +99                        |
|  |                    | G-R    | -99 - 0 - +99                        |
|  |                    | G-B    | -99 - 0 - +99                        |
|  |                    | B-R    | -99 - 0 - +99                        |
|  |                    | B-G    | -99 - 0 - +99                        |
|  | Mode: Indoor       | Matrix | Off, On                              |
|  |                    | Select | Standard, Fl. Light, High Saturation |
|  |                    | Level  | 00 - 14                              |
|  |                    | Phase  | -7 - +7                              |
|  |                    | R-G    | -99 - 0 - +99                        |
|  |                    | R-B    | -99 - 0 - +99                        |
|  |                    | G-R    | -99 - 0 - +99                        |
|  |                    | G-B    | -99 - 0 - +99                        |
|  |                    | B-R    | -99 - 0 - +99                        |
|  |                    | B-G    | -99 - 0 - +99                        |
|  | Mode: Outdoor      | Matrix | Off, On                              |
|  |                    | Select | Standard, Fl. Light, High Saturation |
|  |                    | Level  | 00 - 14                              |
|  |                    | Phase  | -7 - +7                              |
|  |                    | R-G    | -99 - 0 - +99                        |
|  |                    | R-B    | -99 - 0 - +99                        |
|  |                    | G-R    | -99 - 0 - +99                        |
|  |                    | G-B    | -99 - 0 - +99                        |
|  |                    | B-R    | -99 - 0 - +99                        |
|  |                    | B-G    | -99 - 0 - +99                        |
|  | Mode: OPW          | Offset | -7 - +7                              |
|  |                    | Matrix | Off, On                              |
|  |                    | Select | Standard, Fl. Light, High Saturation |
|  |                    | Level  | 00 - 14                              |
|  |                    | Phase  | -7 - +7                              |
|  |                    | R-G    | -99 - 0 - +99                        |
|  |                    | R-B    | -99 - 0 - +99                        |
|  |                    | G-R    | -99 - 0 - +99                        |
|  |                    | G-B    | -99 - 0 - +99                        |
|  |                    | B-R    | -99 - 0 - +99                        |
|  |                    | B-G    | -99 - 0 - +99                        |
|  | Mode: ATW          | Speed  | 01 - 05                              |
|  |                    | Offset | -7 - +7                              |
|  |                    | Matrix | Off, On                              |
|  |                    | Select | Standard, Fl. Light, High Saturation |
|  |                    | Level  | 00 - 14                              |
|  |                    | Phase  | -7 - +7                              |
|  |                    | R-G    | -99 - 0 - +99                        |
|  |                    | R-B    | -99 - 0 - +99                        |
|  |                    | G-R    | -99 - 0 - +99                        |
|  |                    | G-B    | -99 - 0 - +99                        |
|  |                    | B-R    | -99 - 0 - +99                        |
|  |                    | B-G    | -99 - 0 - +99                        |
|  | Mode: User         | R Gain | 000 - 255                            |
|  |                    | B Gain | 000 - 255                            |
|  |                    | Matrix | Off, On                              |
|  |                    | Select | Standard, Fl. Light, High Saturation |
|  |                    | Level  | 00 - 14                              |
|  |                    | Phase  | -7 - +7                              |
|  |                    | R-G    | -99 - 0 - +99                        |
|  |                    | R-B    | -99 - 0 - +99                        |
|  |                    | G-R    | -99 - 0 - +99                        |
|  |                    | G-B    | -99 - 0 - +99                        |
|  |                    | B-R    | -99 - 0 - +99                        |
|  |                    | B-G    | -99 - 0 - +99                        |
|  | Mode: Outdoor Auto | Matrix | Off, On                              |

|         |                     |                     |                                      |
|---------|---------------------|---------------------|--------------------------------------|
|         |                     | Select              | Standard, Fl. Light, High Saturation |
|         |                     | Level               | 00 - 14                              |
|         |                     | Phase               | -7 - +7                              |
|         |                     | R-G                 | -99 - 0 - +99                        |
|         |                     | R-B                 | -99 - 0 - +99                        |
|         |                     | G-R                 | -99 - 0 - +99                        |
|         |                     | G-B                 | -99 - 0 - +99                        |
|         |                     | B-R                 | -99 - 0 - +99                        |
|         |                     | B-G                 | -99 - 0 - +99                        |
|         | Mode: SVL Auto      | Matrix              | Off, On                              |
|         |                     | Select              | Standard, Fl. Light, High Saturation |
|         |                     | Level               | 00 - 14                              |
|         |                     | Phase               | -7 - +7                              |
|         |                     | R-G                 | -99 - 0 - +99                        |
|         |                     | R-B                 | -99 - 0 - +99                        |
|         |                     | G-R                 | -99 - 0 - +99                        |
|         |                     | G-B                 | -99 - 0 - +99                        |
|         |                     | B-R                 | -99 - 0 - +99                        |
|         |                     | B-G                 | -99 - 0 - +99                        |
|         | Mode: SVL           | Matrix              | Off, On                              |
|         |                     | Select              | Standard, Fl. Light, High Saturation |
|         |                     | Level               | 00 - 14                              |
|         |                     | Phase               | -7 - +7                              |
|         |                     | R-G                 | -99 - 0 - +99                        |
|         |                     | R-B                 | -99 - 0 - +99                        |
|         |                     | G-R                 | -99 - 0 - +99                        |
|         |                     | G-B                 | -99 - 0 - +99                        |
|         |                     | B-R                 | -99 - 0 - +99                        |
|         |                     | B-G                 | -99 - 0 - +99                        |
|         | Mode: SVL Outdoor A | Matrix              | Off, On                              |
|         |                     | Select              | Standard, Fl. Light, High Saturation |
|         |                     | Level               | 00 - 14                              |
|         |                     | Phase               | -7 - +7                              |
|         |                     | R-G                 | -99 - 0 - +99                        |
|         |                     | R-B                 | -99 - 0 - +99                        |
|         |                     | G-R                 | -99 - 0 - +99                        |
|         |                     | G-B                 | -99 - 0 - +99                        |
|         |                     | B-R                 | -99 - 0 - +99                        |
|         |                     | B-G                 | -99 - 0 - +99                        |
| Detail  | Mode: Auto          | Level               | 00 - 15                              |
|         | Mode: Manual        | Bandwidth           | Default, Low, Middle, High, Wide     |
|         |                     | Sharpness           | 00 - 07                              |
|         |                     | H/V Balance         | -2 - +2                              |
|         |                     | B/W Balance         | Type 1 - Type 5                      |
|         |                     | Limit               | 00 - 07                              |
|         |                     | Highlight Detail    | 00 - 04                              |
|         |                     | Super Low           | 00 - 07                              |
| Picture |                     | 2D NR               | Off, 01 - 05                         |
|         |                     | 3D NR               | Off, 01 - 05                         |
|         |                     | Flip                | Off, On                              |
|         |                     | Mirror              | Off, On                              |
|         |                     | ND Filter           | Off 1/4 1/16 1/64                    |
|         |                     | Effect              | Day, Night                           |
|         |                     | Chroma Suppress     | Off, Low, Middle, High               |
|         |                     | HLC Mode            | Off, On                              |
|         |                     | Scenes              | Standard, Bright, Clarity, Soft      |
| Gamma   | Standard            | Offset              | -64 - +64                            |
|         |                     | Level               | -7 - +7                              |
|         |                     | Black Gamma         | -7 - +7                              |
|         |                     | Black Gamma Range   | Low, Middle, High                    |
|         |                     | Black Level         | -48 - +48                            |
|         |                     | Visibility Enhancer | Off, On                              |



|          |                      |                     |   |
|----------|----------------------|---------------------|---|
|          |                      | VE Effect           | -3 - +3   |
|          | Straight             | Offset              | -64 - +64   |
|          |                      | Level               | -7 - +7   |
|          |                      | Black Gamma         | -7 - +7   |
|          |                      | Black Gamma Range   | Low, Middle, High   |
|          |                      | Black Level         | -48 - +48   |
|          |                      | Visibility Enhancer | Off, On   |
|          |                      | VE Effect           | -3 - +3   |
|          | Pattern              | Pattern             | 00 - 51   |
|          |                      | Pattern Fine        | 00 - 09   |
|          |                      | Offset              | -64 - +64   |
|          |                      | Level               | -7 - +7   |
|          |                      | Black Gamma         | -7 - +7   |
|          |                      | Black Gamma Range   | Low, Middle, High   |
|          |                      | Black Level         | -48 - +48   |
|          |                      | Visibility Enhancer | Off, On   |
|          |                      | VE Effect           | -3 - +3   |
| Lens     | Zoom Ration OSD      |                     | Off, On   |
|          | AF Mode              |                     | Auto, Manual  |
|          | AF Sensitivity       |                     | Normal, Low   |
|          | MF Speed             |                     | 00 - 07   |
|          | Near Limit           |                     | Over 8CM 10CM 14CM* 18CM 25CM 35CM 55CM 80CM 1.0M 1.2M 1.5M 2M 3M 5M                                |
|          | Stabilizer           |                     | Off, On   |
| Pan Tilt | Adaptive P/T         |                     | Off, On   |
|          | P/T Speed            |                     | 00 - 05   |
|          | Pan Direction        |                     | Normal, Invert  |
|          | Tilt Direction       |                     | Normal, Invert  |
|          | Preset               | Preset Memory       | Standard, Extended  |
|          |                      | Preset Speed        | 00 - 05   |
|          |                      | Motionless Preset   | Off, On   |
|          |                      | Reload Preset 1     | Off, On   |
| Genlock  | H Phase              |                     | -127 - 0 - +127   |
| System   | Pelco ID             |                     | 001 - 255   |
|          | VISCA ID             |                     | 001 - 007   |
|          | IR ID                |                     | 01 - 03   |
|          | IR Receive           |                     | Off, On   |
|          | Comm Type            |                     | RS422   |
|          | Baud Rate            |                     | 2400,4800,9600,38400  |
|          | Display Info         |                     | Off, On   |
|          | Video Parameters OSD |                     | Off, On   |
|          | Tally Mode           |                     | Off, On   |
|          | Audio                |                     | Off, On   |
|          |                      | Input Type          | Line  |
|          |                      | Volume Level        | -60dB - +18dB (Increments of 2 dB)  |
|          |                      | Phantom Power       | Off, On   |
|          | Color Space          | SDI                 | YUV422  |
|          |                      | HDMI                | RGB, YUV422   |
|          | System Format        | 2160P30             | HDMI: 2160P30 1080P30<br>SDI: 2160P30 1080P30   |
|          |                      | 2160P29.97          | HDMI: 2160P29.97 1080P29.97<br>SDI: 2160P29.97 1080P29.97   |
|          |                      | 2160P25             | HDMI: 2160P25 1080P25<br>SDI: 2160P25 1080P25   |
|          |                      | 2160P24             | HDMI: 2160P24 1080P24<br>SDI: 2160P24 1080P24   |
|          |                      | 2160P23.98          | HDMI: 2160P23.98 1080P23.98<br>SDI: 2160P23.98 1080P23.98   |
|          |                      | 1080P60             | HDMI: 1080P60 1080P30 1080i60 720P60<br>SDI: 1080P60 1080P30 1080i60 720P60                         |
|          |                      | 1080P59.94          | HDMI: 1080P59.94 1080P29.97 1080i59.94 720P59.94<br>SDI: 1080P59.94 1080P29.97 1080i59.94 720P59.94 |
|          |                      | 1080P50             | HDMI: 1080P50 1080P25 1080i50 720P50<br>SDI: 1080P50 1080P25 1080i50 720P50                         |
|          | Factory Reset        |                     | Yes, No   |
| Status   | Pelco ID             |                     |   |
|          | VISCA ID             |                     |   |

|                               |  |
|-------------------------------|--|
| IR ID                         |  |
| Baud Rate                     |  |
| Comm Type                     |  |
| HDMI Format                   |  |
| SDI Format                    |  |
| FPGA FW                       |  |
| MCU FW                        |  |
| EXP Mode                      |  |
| WB Mode                       |  |
| Visibility Enhancer           |  |
| Black Level                   |  |
| Matrix                        |  |
| <a href="#">Next Page</a>     |  |
| Adaptive P/T                  |  |
| Flip                          |  |
| Mirror                        |  |
| ND Filter                     |  |
| Stabilizer                    |  |
| P/T Speed                     |  |
| Preset Speed                  |  |
| IP Address                    |  |
| MAC Address                   |  |
| <a href="#">Previous Page</a> |  |

## EXU-420F OSD Menu Structure

|               |                        |                |  |
|---------------|------------------------|----------------|--|
| Exposure      | Mode: Full Auto        | Gain Limit     | 1 - 255  |
|               |                        | Ex-Comp        | -50 - +50  |
|               | Mode: Manual           | Gain           | 1 - 255  |
|               |                        | Speed          | 1/25 1/30 1/50 1/60 1/90 1/100 1/125 1/180 1/195 1/215 1/230 1/250 1/350 1/500 1/725 1/1000 1/1500 1/2000 1/3000 1/4000 1/6000 1/10K 1/30K 1/100K  |
|               |                        | Iris           | F1.80,F1.81,F1.82,F1.83,F1.84,F1.85,F1.86,F1.87,F1.88,F1.89,F1.90,F1.91,F1.92,F1.93,F1.94,F1.95,F1.96,F1.97,F1.98,F1.99,F2.00,F2.01,F2.02,F2.03,04,F2.05,F2.06,F2.07,F2.08,F2.09,F2.10,F2.11,F2.12,F2.13,F2.14,F2.15,F2.16,F2.17,F2.18,19,F2.20,21,F2.22,F2.23,F2.24,F2.25,F2.26,F2.27,F2.28,F2.29,F2.30,F2.31,32,F2.33,F2.34,F2.35,36,F2.37,F2.38,39,F2.40,F2.41,F2.42,F2.43,44,F2.45,F2.46,F2.47,F2.48,F2.49,F2.50,51,F2.52,F2.53,F2.54,F2.55,F2.56,57,F2.58,F2.59,60,F2.61,F2.62,F2.63,F2.64,F2.65,F2.67,F2.68,F2.69,F2.70,F2.71,F2.72,F2.73,F2.74,F2.75,F2.76,F2.77,F2.78,F2.79,F2.80,F2.82,F2.84,F2.86,F2.88,F2.90,F2.92,F2.94,96,F2.98,F3.00,F3.02,F3.04,F3.06,F3.08,F3.10,F3.12,F3.14,F3.16,F3.18,F3.20,F3.22,F3.24,F3.26,F3.28,F3.30,F3.32,F3.34,F3.36,F3.38,F3.40,F3.42,F3.44,F3.46,F3.48,F3.51,F3.54,F3.57,F3.60,F3.63,F3.66,F3.69,F3.72,F3.75,F3.79,F3.83,F3.87,F3.91,F3.95,F3.99,F4.03,F4.07,F4.11,F4.15,F4.19,F4.23,F4.27,F4.31,F4.35,F4.39,43,F4.47,F4.51,F4.55,F4.59,F4.63,F4.67,F4.72,F4.77,F4.82,F4.87,F4.92,F4.97,F5.12,20,F5.30,F5.40,50,60,F5.70,F5.80,F5.90,F6.00,F6.10,20,F6.30,F6.40,50,F6.60,F6.70,F6.80,F6.90,F7.00,10,F7.20,F7.30,F7.40,F7.50,F7.60,F7.70,F7.80,F8.00,F8.20,40,F8.60,F8.80,F9.00,F9.40,F9.80,F10.2,F10.6,F11.0,F11.4,F12.0,F12.5,F13.0,F13.5,F14.0,F14.5,F15.0,F15.5,F16.0,F16.5,F17.0,F17.5,F18.0,F18.5,F19.0,F19.5,F20.0,F20.5,F21.0,F21.5,F22.0,F22.5,F23.0,F23.5,F24.0,F24.5,F25.0,F25.5,F26.0,F26.5,F27.0,F27.5,F28.0,F28.5,F29.0,F29.5,F30.0,F30.5,F31.0,F31.5,F32.0,F32.5,CLOSE |
|               |                        | Smart Exposure | Off, On  |
|               | Mode: Iris Priority    | Iris           | F1.80,F1.81,F1.82,F1.83,F1.84,F1.85,F1.86,F1.87,F1.88,F1.89,F1.90,F1.91,F1.92,F1.93,F1.94,F1.95,F1.96,F1.97,F1.98,F1.99,F2.00,F2.01,F2.02,F2.03,04,F2.05,F2.06,F2.07,F2.08,F2.09,F2.10,F2.11,F2.12,F2.13,F2.14,F2.15,F2.16,F2.17,F2.18,19,F2.20,21,F2.22,F2.23,F2.24,F2.25,F2.26,F2.27,F2.28,F2.29,F2.30,F2.31,32,F2.33,F2.34,F2.35,36,F2.37,F2.38,39,F2.40,F2.41,F2.42,F2.43,44,F2.45,F2.46,F2.47,F2.48,F2.49,F2.50,51,F2.52,F2.53,F2.54,F2.55,F2.56,57,F2.58,F2.59,60,F2.61,F2.62,F2.63,F2.64,F2.65,F2.67,F2.68,F2.69,F2.70,F2.71,F2.72,F2.73,F2.74,F2.75,F2.76,F2.77,F2.78,F2.79,F2.80,F2.82,F2.84,F2.86,F2.88,F2.90,F2.92,F2.94,96,F2.98,F3.00,F3.02,F3.04,F3.06,F3.08,F3.10,F3.12,F3.14,F3.16,F3.18,F3.20,F3.22,F3.24,F3.26,F3.28,F3.30,F3.32,F3.34,F3.36,F3.38,F3.40,F3.42,F3.44,F3.46,F3.48,F3.51,F3.54,F3.57,F3.60,F3.63,F3.66,F3.69,F3.72,F3.75,F3.79,F3.83,F3.87,F3.91,F3.95,F3.99,F4.03,F4.07,F4.11,F4.15,F4.19,F4.23,F4.27,F4.31,F4.35,F4.39,43,F4.47,F4.51,F4.55,F4.59,F4.63,F4.67,F4.72,F4.77,F4.82,F4.87,F4.92,F4.97,F5.12,20,F5.30,F5.40,50,60,F5.70,F5.80,F5.90,F6.00,F6.10,20,F6.30,F6.40,50,F6.60,F6.70,F6.80,F6.90,F7.00,10,F7.20,F7.30,F7.40,F7.50,F7.60,F7.70,F7.80,F8.00,F8.20,40,F8.60,F8.80,F9.00,F9.40,F9.80,F10.2,F10.6,F11.0,F11.4,F12.0,F12.5,F13.0,F13.5,F14.0,F14.5,F15.0,F15.5,F16.0,F16.5,F17.0,F17.5,F18.0,F18.5,F19.0,F19.5,F20.0,F20.5,F21.0,F21.5,F22.0,F22.5,F23.0,F23.5,F24.0,F24.5,F25.0,F25.5,F26.0,F26.5,F27.0,F27.5,F28.0,F28.5,F29.0,F29.5,F30.0,F30.5,F31.0,F31.5,F32.0,F32.5,CLOSE |
|               |                        | Gain Limit     | 1 - 255  |
|               |                        | Smart Exposure | Off, On  |
|               | Mode: Shutter Priority | Speed          | 1/25 1/30 1/50 1/60 1/90 1/100 1/125 1/180 1/195 1/215 1/230 1/250 1/350 1/500 1/725 1/1000 1/1500 1/2000 1/3000 1/4000 1/6000 1/10K 1/30K 1/100K  |
|               |                        | Gain Limit     | 1 - 255  |
|               |                        | Smart Exposure | Off, On  |
| White Balance | Mode: Auto             | WB Sensitivity | Low, Middle, High  |
|               |                        | R Tuning       | 000 - 100  |
|               |                        | G Tuning       | 000 - 100  |
|               |                        | B Tuning       | 000 - 100  |
|               | Mode: Indoor           | WB Sensitivity | Low, Middle, High  |
|               |                        | R Tuning       | 000 - 100  |
|               |                        | G Tuning       | 000 - 100  |
|               |                        | B Tuning       | 000 - 100  |
|               | Mode: Outdoor          | WB Sensitivity | Low, Middle, High  |
|               |                        | R Tuning       | 000 - 100  |
|               |                        | G Tuning       | 000 - 100  |
|               |                        | B Tuning       | 000 - 100  |
|               | Mode: OPW              | WB Sensitivity | Low, Middle, High  |

|          |                            |                   |   |
|----------|----------------------------|-------------------|---|
|          |                            | R Tuning          | 000 - 100   |
|          |                            | G Tuning          | 000 - 100   |
|          |                            | B Tuning          | 000 - 100   |
|          | Mode: ATW                  | WB Sensitivity    | Low, Middle, High   |
|          |                            | R Tuning          | 000 - 100   |
|          |                            | G Tuning          | 000 - 100   |
|          |                            | B Tuning          | 000 - 100   |
|          | Mode: User                 | WB Sensitivity    | Low, Middle, High   |
|          |                            | R Tuning          | 000 - 100   |
|          |                            | G Tuning          | 000 - 100   |
|          |                            | B Tuning          | 000 - 100   |
|          | Mode: SVL                  | WB Sensitivity    | Low, Middle, High   |
|          |                            | R Tuning          | 000 - 100   |
|          |                            | G Tuning          | 000 - 100   |
|          |                            | B Tuning          | 000 - 100   |
|          | Mode: Manual               | WB Sensitivity    | Low, Middle, High   |
|          |                            | R Tuning          | 000 - 100   |
|          |                            | G Tuning          | 000 - 100   |
|          |                            | B Tuning          | 000 - 100   |
| Picture  | Sharpness                  |                   | 000 - 100   |
|          | 2D NR                      |                   | 000 - 100   |
|          | 3D NR                      |                   | 000 - 100   |
|          | Flip                       |                   | Off, On   |
|          | Mirror                     |                   | Off, On   |
|          | Hue                        |                   | 000 - 100   |
|          | Saturation                 |                   | 000 - 100   |
|          | Contrast                   |                   | 000 - 100   |
|          | Effect                     |                   | Auto, Day, Night  |
|          | Scene                      |                   | Standard, Bright, Clarity, Soft   |
|          | Defog Mode                 |                   | Off, Auto, Manual   |
|          | Defog Level                |                   | 000 - 100   |
|          | Bright                     |                   | 000 - 100   |
|          | HLC Mode                   |                   | Off, On   |
|          | <a href="#">Next Page</a>  |                   |   |
|          | Backlight Comp.            |                   | Off, On   |
|          | WDR                        |                   | Off, On   |
|          | WDR Level                  |                   | 000 - 100   |
|          | De-Flicker                 |                   | Off, 50, 60   |
|          | Gamma                      |                   | Default, 0.45, 0.50, 0.55, 0.63   |
|          | <a href="#">Prev. Page</a> |                   |   |
| Lens     | Digital Zoom               |                   | Off, On   |
|          | Zoom Ratio OSD             |                   | Off, On   |
|          | AF Mode                    |                   | Manual, OnePush   |
|          | AF Area                    |                   | Default, All, Top, Center, Bottom   |
|          | Smart Focus                |                   | Off, On   |
|          | AF Sensitivity             |                   | High, Middle, Low   |
|          | Zoom Speed                 |                   | 0 - 7   |
|          | MF Speed                   |                   | 0 - 7   |
|          | Near Limit                 |                   | INF, 180m, 100m, 60m, 21m, 10m, 5m, 3m, 2m, 1.5m, 1.0m, 75cm, 50cm, 30cm, 1cm |
|          | Stabilizer                 |                   | Off, On   |
| Pan Tilt | Adaptive PT                |                   | Off, On   |
|          | P/T Speed                  |                   | 0 - 5   |
|          | Pan Direction              |                   | Normal, Invert  |
|          | Tilt Direction             |                   | Normal, Invert  |
|          | Preset                     | Preset Memory     | Standard, Extended  |
|          |                            | Preset Speed      | 0 - 5   |
|          |                            | Motionless Preset | Off, On   |

|                            |                           |                 |   |  |
|----------------------------|---------------------------|-----------------|---|--|
|                            |                           | Reload Preset 1 | Off, On   |  |
| Genlock                    | H Phase                   |                 | -127 - +127   |  |
| System                     | Pelco ID                  |                 | 001 - 255   |  |
|                            | VISCA ID                  |                 | 001 - 007   |  |
|                            | IR ID                     |                 | 1   |  |
|                            | IR Receive                |                 | Off, On   |  |
|                            | Comm Type                 |                 | RS422   |  |
|                            | Baud Rate                 |                 | 2400, 4800, 9600, 38400   |  |
|                            | Display Info              |                 | Off, On   |  |
|                            | Video Parameters OSD      |                 | Off, On   |  |
|                            | Tally Mode                |                 | Off, On   |  |
|                            | Audio                     |                 | Off, On   |  |
|                            |                           | Input Type      | Line  |  |
|                            |                           | Volume Level    | -60 dBu - +18 dBu   |  |
|                            |                           | Phantom Power   | Off, On   |  |
|                            | Color Space               |                 | SDI: YUV422<br>HDMI: RGB, YUV422  |  |
|                            | System Format             | 2160P60         | HDMI: 2160P60 2160P30 1080P60 1080P30 1080i60<br>SDI: 2160P60 2160P30 1080P60 1080P30 1080i60                               |  |
|                            |                           | 2160P59.94      | HDMI: 2160P59.94 2160P29.97 1080P59.94 1080P29.97 1080i59.94<br>SDI: 2160P59.94 2160P29.97 1080P59.94 1080P29.97 1080i59.94 |  |
|                            |                           | 2160P50         | HDMI: 2160P50 2160P25 1080P50 1080P25 1080i50<br>SDI: 2160P50 2160P25 1080P50 1080P25 1080i50                               |  |
|                            |                           | 2160P24         | HDMI: 2160P24 1080P24<br>SDI: 2160P24 1080P24   |  |
|                            |                           | 2160P23.98      | HDMI: 2160P23.98 1080P23.98<br>SDI: 2160P23.98 1080P23.98   |  |
|                            |                           | 1080P60         | HDMI: 1080P60 1080P30 1080i60 720P60<br>SDI: 1080P60 1080P30 1080i60 720P60   |  |
|                            |                           | 1080P59.94      | HDMI: 1080P59.94 1080P29.97 1080i59.94 720P59.94<br>SDI: 1080P59.94 1080P29.97 1080i59.94 720P59.94                         |  |
|                            |                           | 1080P50         | HDMI: 1080P50 1080P25 1080i50 720P50<br>SDI: 1080P50 1080P25 1080i50 720P50   |  |
|                            | Factory Reset             |                 | Off, On   |  |
| Status                     | PELCO ID                  |                 |   |  |
|                            | VISCA ID                  |                 |   |  |
|                            | IR ID                     |                 |   |  |
|                            | Baud Rate                 |                 |   |  |
|                            | Comm Type                 |                 |   |  |
|                            | HDMI Format               |                 |   |  |
|                            | SDI Format                |                 |   |  |
|                            | FPGA FW                   |                 |   |  |
|                            | MCU FW                    |                 |   |  |
|                            | Exp Mode                  |                 |   |  |
|                            | WB Mode                   |                 |   |  |
|                            | Hue                       |                 |   |  |
|                            | Contrast                  |                 |   |  |
|                            | Saturation                |                 |   |  |
|                            | <a href="#">Next Page</a> |                 |   |  |
|                            | Flip                      |                 |   |  |
|                            | Mirror                    |                 |   |  |
|                            | Stabilizer                |                 |   |  |
|                            | P/T Speed                 |                 |   |  |
|                            | Preset Speed              |                 |   |  |
| Scene                      |                           |                 |   |  |
| IP Address                 |                           |                 |   |  |
| MAC Address                |                           |                 |   |  |
| <a href="#">Prev. Page</a> |                           |                 |   |  |

---

# Technical Specifications

EX-Ultra 248F & 420F User Guide

[www.bolintechnology.com](http://www.bolintechnology.com)

Bolin Technology