



INSA Trading GMBH

Instruction Manual

Manual Guns Types MG801, MG801S and MG850



Automatic Gun AG800

This manual is supplied by INSA Trading GmbH, Switzerland



PHONE 214-477-134 FAX972-317-6889

WWW.EICGROUPUSA.COM



Table of Contents

Foreword	4
Version Information	4
Safety-regulations concerning Electrostatic Powder Coating	5
General notes applying to all guns	7
Introduction.....	7
Generation of high tension.....	8
Technical specifications of the manual and automatic guns.....	9
The Manual Guns Type MG801 and MG801S	10
Introduction.....	10
Differences between the MG801 and the MG801S.....	10
The Manual Gun Type 850	11
Introduction.....	11
Settings at the gun.....	12
High voltage adjustment.....	12
Adjustment of the powder output.....	12
The Automatic Gun AG800	13
Generalities.....	13
Gun Compatibility Chart	14
Manual Guns.....	14
Automatic Gun.....	14
Recommended voltage settings for typical applications	15
Using Muzzles	16
The use of different muzzles.....	16
Function of a deflector muzzle.....	17
Function of a flat spray muzzle.....	18
Options available with INSA Guns	19
Triboelectric Versions.....	19
Muzzle Prolongations.....	19
Low Ion Adaptor.....	20
Cup Gun Attachment	21
Maintenance	22
Generalities.....	22
Daily Check.....	23
Weekly check.....	24
Troubleshooting	25
Parts listing	26
Muzzles and wearable parts.....	26
Parts of the manual guns	28
Special buttons for the MG850.....	30
Parts of the Automatic Gun AG800.....	31
External view.....	31
Internal View.....	32

Illustration Index

Basic operation of the gun	8
The Manual Gun MG801.....	10
The MG850 Gun, companion of the Smarcoat Series.....	11
Settings at the gun.....	12
Different types of muzzles available.....	16
Function of a deflector muzzle	17
Function of a flat spray muzzle.....	18
An MG801 with a low ion adaptor.....	20
Cup gun Attachment for INSA manual units.....	21
Electrode holder position at gun reassembly.....	23
Overview of the muzzles and other wearable parts.....	26
Overview of a disassembled manual gun	28
Special buttons of the MG850	30
The Automatic Gun AG800.....	31
Internal view of an automatic gun type AG800.....	32

Foreword

Thank you for choosing an INSA Powder Coating System. It is a very efficient system with a low consumption of spare parts. In order to gain the most profit from your equipment, please review the different functions and maintenance required as described in this manual.

Important

Please note that INSA Trading GMBH or its representative take no responsibility if the equipment is used outside its specification, or for uses other than those described in this manual.
--

Version Information

Versionofthedocument	2
Dateoflastmodification	2003-07-16

Safety-regulations concerning Electrostatic Powder Coating

1. The equipment can be dangerous when not used in accordance with the requirements of the following standards:
 - EN 50 050 (resp. VDE 0745 chapter 100)
 - EN 50 053 (resp. VDE 0745 chapter 102)
 - Instructions for electrostatic powder coating ZH 1/444
2. All electrostatically conductive parts within a reach of 5 m from the spray area must be grounded.
3. The floor of the room containing the spray area must be electrostatically conductive.
4. The personnel must wear shoes with conductive soles.
5. The personnel that will handle the gun must use it with either bare hands or with electrostatically conductive gloves.
6. The ground wire (green/yellow) has to be connected to the ground screw on the back of the electrostatic control module.

7. The ground wire must have a solid metallic connection with the booth, the recovery system, and the conveyor chain as well as the objects to be coated.
8. The electric cables as well as the powder hoses leading to the guns must be handled in such a way that they are protected against mechanical damage.
9. Only after the recovery system has been put into operation may the powder coating unit be switched on.
10. Electric wires as well as powder hoses have to be examined at least once a week.
11. The grounding of all the electrostatically conductive parts and equipment within the reach of 5m from the spray area must be examined at least once a week.
12. The control panel must be switched off when cleaning the gun or when changing nozzles or extensions.

General notes applying to all guns

Introduction

The manual powder guns with the integrated high voltage generator are designed to apply electrostatically chargeable powder on grounded work-pieces. The guns are designed with state of the art of technology. The parts are assembled in a simple manner which assures easy maintenance and repair. The guns produce high voltage and it is therefore absolutely necessary to read the instruction manual carefully before starting to operate.

All guns are built in accordance with the CE-regulations. They have been tested together with the electronic control board ECB, and have been found to comply with the European Regulation EN 50 050/54 regulation.

Important

The guns and the electronic control board ECB 110 have been used in accordance with the european regulation EN 50 050 as components of a configuration, they can only be used in this combination. Any change or manipulation of the components will automatically void the warranty and any implicated liability. Use of any parts other than original spare parts will void the warranty.

Generation of high tension



The powder gun with the integrated high voltage generator (Pos.1 in Illustration 1 above) is supplied from the central drawer by the cable (pos.2) with low voltage of 16 kHz frequency. This voltage is transformed to high AC tension and afterwards multiplied up to 110 kV at the electrode (pos.3). The powder hose is connected to the hose connector (pos.4). When the gun trigger (Pos. 5) is pressed, the magnetic valve will activate (for compressed air) along with the voltage supply to the gun. The grounded plate (Pos. 6) at the handle will ensure the operator is not charged.

Technical specifications of the manual and automatic guns

Inputvoltage:	10,5V _{eff}
Frequency:	17kHz
OutputVoltage:	110kV-10%
Max.Outputcurrent:	140μA
Polarity:	negative
Licence:	EN50050
ExaminationNo:	BVS97.D.2048

The Manual Guns Type MG801 and MG801S

Introduction

The Manual Gun Series MG801 is a very rugged, well balanced, and light unit, designed to withstand day-to-day powder coating operations. This gun is delivered as standard with all units of Type 5100, but it may be used on **any** of the many INSA units.

Illustration 2: The Manual Gun MG801



Differences between the MG801 and the MG801S

The MG801 was constructed and is optimized for the use with a Series 5100 Manual Unit.

The MG801S was built to operate on the Series 5300 'Suitcase' Unit. This Unit is ideal for coating small batches of different parts, or to do powder tests. The MG801S is delivered with a cup attachment as standard.

The Manual Gun Type 850

Introduction

The INSA Manual Gun MG850 was specially designed to be used with the INSA Series 5800 Smartcoat Drawer Type 5800. With this drawer, it can offer special functionality, as described below.

The Series 850 Manual gun will operate on any INSA Drawer. The drawer may limit its functionality though, and not allow the use of all the push button functions at the gun.

Illustration 3 The MG850 Gun, companion of the Smarcoat Series



Settings at the gun

Illustration 4 Settings at the gun



High voltage adjustment

The gun has a switch (Position 1 in Illustration 4) which allows the adaptation of the voltage to difficult coating situations (Faraday corners).

When the button is pushed, it will be locked in place. This will result in a reduction of the voltage, and yield more uniform results and easier coating of corners and hard to coat areas.

When the button is pushed again, the voltage will return to the level it was before.

Adjustment of the powder output

The operator can adjust the level of powder output directly at the gun by pushing the buttons labeled '-' or '+' (Positions 2 and 3 in Illustration 4). When the button is pressed, the output will change in the indicated direction. As soon as the button is released the change stops.

Please note that the adjustment as described above requires a drawer of the Smartcoat type (Series 5800)

The Automatic Gun AG800

Generalities

The automatic gun AG800 is available in different variants, which are different in their polarity, and input voltage. Those differences have been color coded:

<i>Color</i>	<i>Variant</i>
Green	Standardvariant,negativepolarity
Red	Positivepolarity
Grey	Negativepolarity,9Vinputvoltage

The muzzles and other accessories are compatible with the automatic gun, so please consult the respective sections to find a muzzle suitable for your application.

Distances in the powder booth

To reach near optimal coating performance, the minimal distance from the front part of the automatic gun AG800 to the grounded part should be at least 100mm. Using distances lower than this may lead to a charging of the cascade, which may cause damage to it.

Gun Compatibility Chart

Manual Guns

<i>GunModel</i>	<i>Series5300Suitcase</i>	<i>Series5100Manual</i>	<i>Series5800Smartcoat</i>
MG801S	O	O	N
MG801	O	O	N
MG850	X	X	O

O = Fully Compatible

N = Gun is usable and works fine, but does not use the full potential of the drawer

X = Gun is usable and works fine, but the drawer can not support all the functionality of the gun

Automatic Gun

<i>GunModel</i>	<i>Series5500Standard Automatic</i>	<i>Series5800Advanced Automatic'MerlinSystem'</i>
AG800	O	O

O = Fully Compatible

N = Gun is usable and works fine, but does not use the full potential of the drawer

X = Gun is usable and works fine, but the drawer can not support all the functionality of the gun

Recommended voltage settings for typical applications

The adjustment of the voltage can be done at the control drawer type 5100 or 5800, or the panel of the 5300 Series 'Suitcase' Unit.

The powder application is variable, and depends on several external factors:

- Type of powder used
- Desired thickness of the powder film
- Range of different parts to be coated

The table below is provided as a starting point.

We recommend the following settings for a typical application:

<i>Voltage</i>	<i>Typical Application</i>
100kV	Large flat parts, film thickness 60 micron
80kV	General application
60kV	Profile coating
50kV	Application of metallic powder

Please note that the MG801S type gun delivered with the Series 5300 Suitcase unit is limited to an output voltage of about 80kV.

Using Muzzles

The use of different muzzles

As described below, muzzles can be used to adapt the powder cloud to different situations. There are two different types of muzzles available, as shown in Illustration 5. Position 1 on the left hand side depicts a deflector muzzle, Position 2 on the right shows a flat spray muzzle. Both types exist in variations, to achieve gradual differences in the desired effect.

Illustration 5 Different types of muzzles available

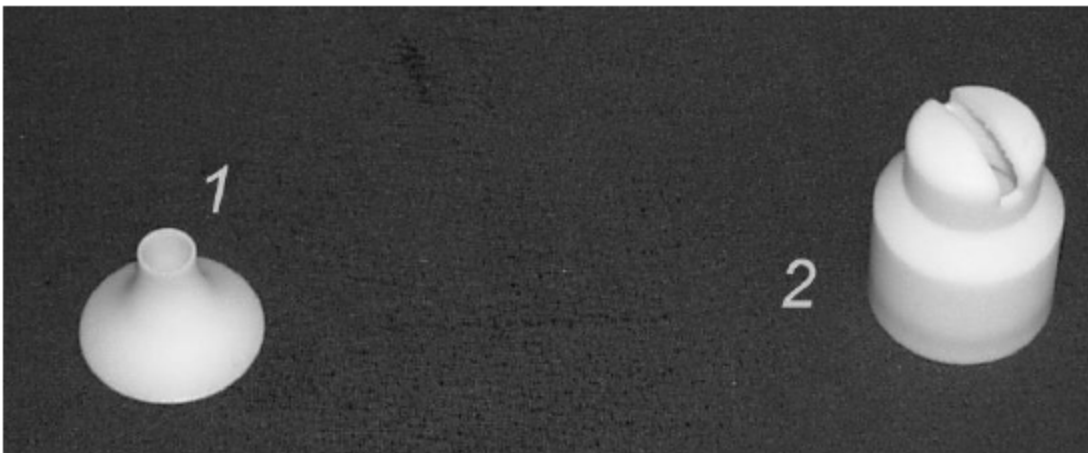

Function of a deflector muzzle

Illustration 6 Function of a deflector muzzle

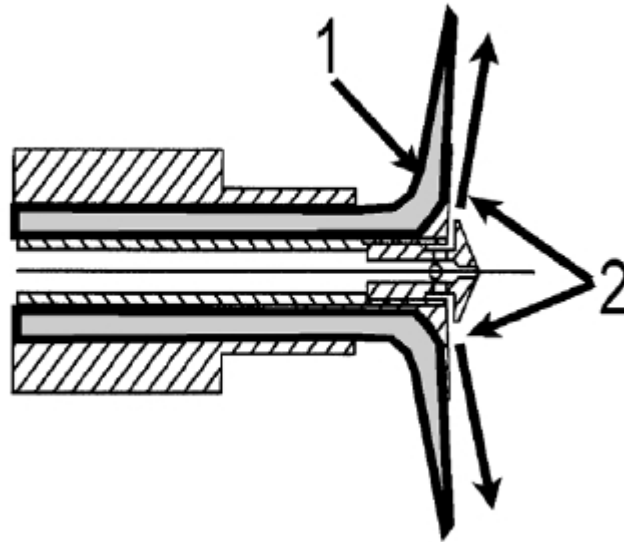

Position 1 in Illustration 6 shows the powder flow. The deflector cleaning air prevents a powder buildup at the deflector (Pos. 2)

Illustration 7 Function of a flat spray muzzle

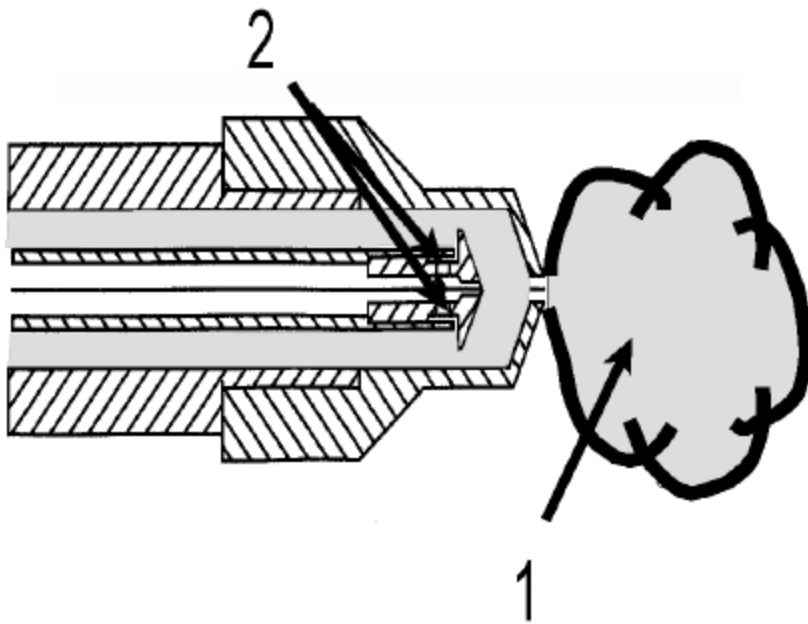

Function of a flat spray muzzle

As can be seen in Illustration 7, the powder exits through the slot of the muzzle and creates a flat cloud (Pos. 1). The speed at the exit can be adjusted through the pressure of the cleaning air (Pos. 2). There are different variants of this muzzle which will create different shapes of clouds.

Options available with INSA Guns

Various options are available with INSA guns:

- Triboelectric Versions instead of electrostatic versions
- Muzzle extensions
- Low Ion Adaptor
- Cup Gun Attachment

Triboelectric Versions

INSA guns are available for both triboelectric charging as well as electrostatic charging.

All INSA Units can be used with triboelectric versions and electrostatic versions.

Muzzle Prolongations

The distance between the gun and the parts to be coated may be too far, or there are other special cases requiring a longer length of the muzzle. Please contact your local representative, or INSA in Switzerland if you need more information and pricing.

Low Ion Adaptor

All INSA guns can be equipped with a low ion adaptor. Illustration 8 shows an MG801 with such an adaptor. The adaptor reduces the number of free ions. Its use will result in the following:

- More uniform coating, esp. less variation in the depth of the powder covering
- Less 'orange peel'
- Better penetration in faraday corners

Illustration 8 An MG801 with a low ion adaptor



Cup Gun Attachment

All manual units allow the mounting of a cup gun attachment. Such an attachment is shown in illustration 9 below. The attachment is usually mounted where the powder hose would be and has the following benefits:

- Allows small quantities of powder to be used
- Container holds about 1.5 Litres
- Built-in fluidization of the powder and powder injector

Illustration 9 Cup gun Attachment for INSA manual units



When the main application is coating small batches of parts, a cup gun attachment may be more economical than a powder hopper.

Maintenance

Generalities

A regular maintenance of the system is necessary in order to assure uniform results. It will also prolong the lifetime of the components of your system.

**Please take note of the following points before doing
any maintenance work**

- Before disassembling the gun, the control drawer must be switched off.
- The gun plug must to be disconnected.
- The compressed air used for cleaning the gun must be free of oil and water.
- It will only be necessary to remove the muzzle assembly. There are no further user-serviceable parts.

Daily Check

Clean the outside of the gun.

Remove the muzzle assembly including the electrode holder and clean it.

Pull out the electrode holder and clean it carefully

the gun has to be cleaned with compressed air at the powder hose connector, following the direction of the powder flow.

The thread of the gun barrel as well as the inside has to be cleaned with compressed air.

Clean the powder hose

Re-assemble the gun and connect it with the drawer.

Please Note

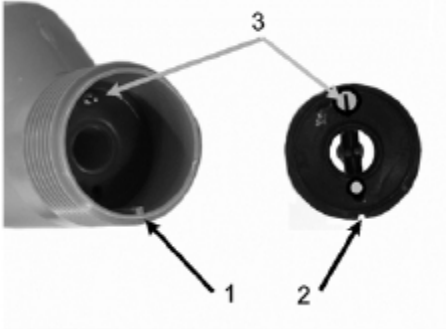

Illustration 10 Electrode holder position at gun reassembly

- When reassembling the electrode holder and the muzzle it has to be ascertained that the groove in the electrode holder (pos.2) and the muzzle correspond with the guide (pos.1) in the gun.
- The contact hole in the electrode holder must be free of powder to assure a good electrical contact. This prolongs the lifetime of the electrode holder and gives the best coating performance.

Weekly check

clean the injector

change the insert sleeve, if necessary (wear part)

clean the gun with compressed air

disassemble and clean the gun carefully

replace the deflectors if necessary (wear part)

replace the muzzle if necessary (wear part)

disassemble the injector completely and clean all parts, ev. Change the insert sleeve (wear part)

Please Note

Other than the muzzle, the gun contains no other user serviceable parts.

Troubleshooting

Caution

Before opening the casing, switch off the electrical voltage and disconnect the electric cable.

<i>Failure</i>	<i>Causesoffailure</i>	<i>Howtofixthem</i>
Novoltagesupply	-mainsupplynotconnected -brokencable -inputfusedefect	-connectit -replaceit -replaceit
Nolightonmainswitch	-lampdefect	-replaceit
Nohightension	-ECB100defect -cascadedefect -gunswitchdefect -cablebroken	-replaceit -replaceit -replaceit -replaceit
Powderpoorlycharged	-nohightension -electrodecoveredwith powder -partsnotgrounded -faultycascade	-followabovementioned advice -cleanit -connectthemtground -replaceit
Nopowderflow	-examinetheinputpressure -defectivemagneticvalve -ECB110defect	-Replaceit -replaceit
Insufficientcoatinginthe corners	-Powderoutputspeedtoohigh -voltage-toohigh	-reduceairpressure -reduceit

Parts listing

Muzzles and wearable parts

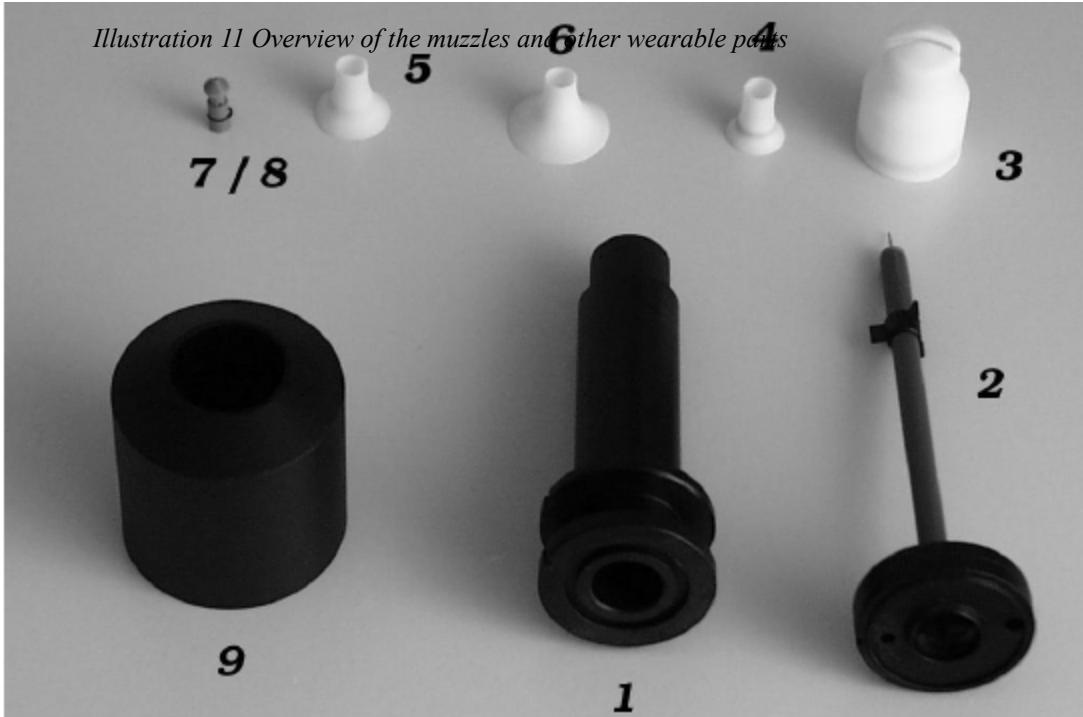

Different muzzles and wear parts are available to be used with the different INSA Guns. All spare parts can be used with all INSA Guns. To get uniform, reproducible results, wear parts should be replaced as soon as a deterioration is apparent.

Please refer to Illustration 11, and to the table on the following page to determine which parts fit your application best.

<i>Pos.</i>	<i>OrderNo.</i>	<i>Description</i>
<i>1</i>	<i>200.104.01</i>	<i>Muzzle100mm</i>
<i>2</i>	<i>200.101.01</i>	<i>Electrodeholder110mm</i>
<i>3</i>	<i>200.106.01</i>	<i>Flatspraynozzle</i>
<i>4</i>	<i>200.110.01</i>	<i>Deflectordia13mm</i>
<i>5</i>	<i>200.111.01</i>	<i>Deflectordia18mm</i>
<i>6</i>	<i>200.112.01</i>	<i>Deflectordia24mm</i>
<i>7</i>	<i>200.102.01</i>	<i>Airdeflectordia6mm</i>
<i>8</i>	<i>200.102.02</i>	<i>Airdeflectordia10mm</i>
<i>9</i>	<i>200.105.01</i>	<i>Unionnut</i>

Wear Parts are printed in *italic type*

Parts of the manual guns

Please consult Illustration 12 and the table on the following page.

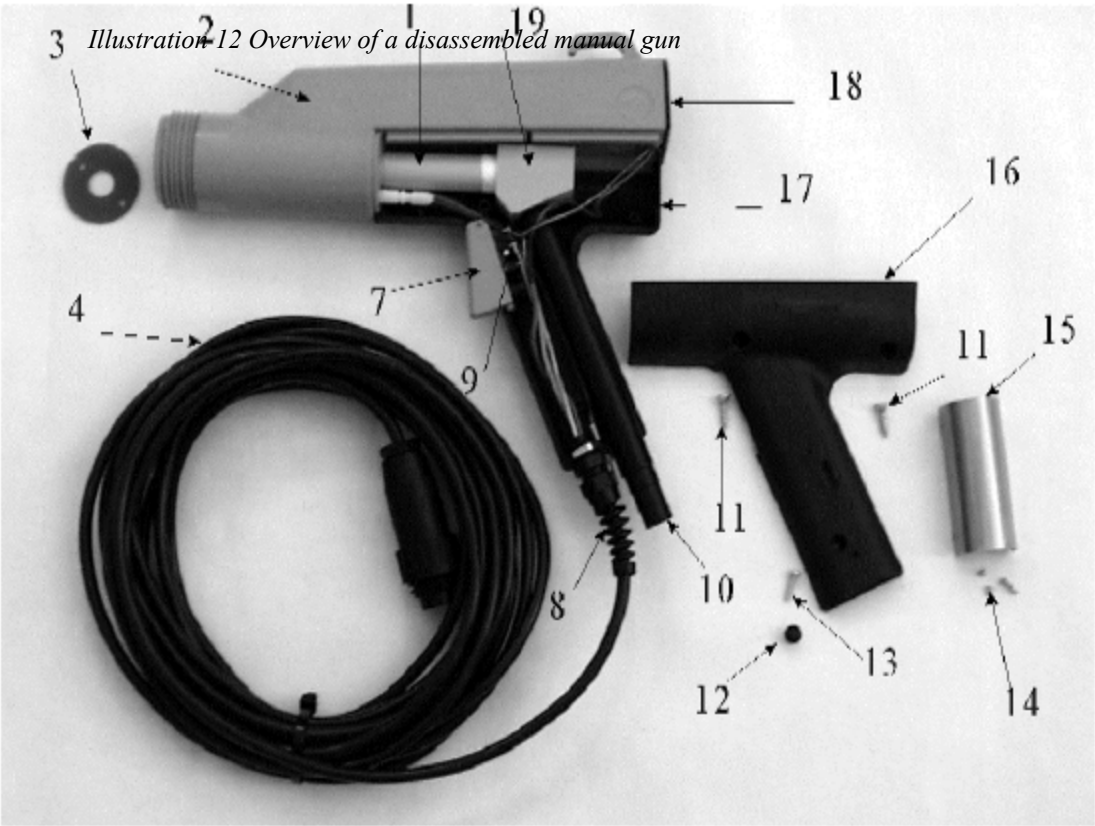

<i>Pos.</i>	<i>Order.No.</i>	<i>Description</i>
1	200.051.01	Powdertube
	201.001.01	HT-Generatorgreennegative
	201.001.02	HT-Generatorredpositive
2	201.001.03	HT-Generatorgrey9Vnegative
3	<i>200.100.01</i>	<i>Rubber-sealing</i>
4	200.001.01	Guncablewithplugtodrawer
7	200.058.01	Guntrigger
8	200.059.01	Cableclamp
9	200.060.01	Gunswitch
10	200.061.01	Powdertubewithhoseconnector
11	200.062.01	Handlescrew
12	200.063.01	Plasticcap
13	200.064.01	Handlescrew
14	200.065.01	Screwforcoverplate
15	200.066.01	Coverplate
16	200.067.01	Upperhandlebodywithpushbutton
17	200.068.01	Lowerhandlebodywithpushbutton
18	201.002.01	Coverplateforcascade
19	200.069.02	Powderdiverter

Wear Parts are printed in *italic type*

Special buttons for the MG850

In addition to the parts outlined above, the MG850 also contains special buttons.

Illustration 13 Special buttons of the MG850



<i>Pos.</i>	<i>OrderNo.</i>	<i>Description</i>
20	200.070.01	Button For Voltage
21	200.071.01	Button For Powder Output

Parts of the Automatic Gun AG800

External view

Illustration 14 The Automatic Gun AG800



<i>Pos.in Illustration 14</i>	<i>OrderNo.</i>	<i>Description</i>
1	Various	Muzzle Please Consult Illustration 11 On Page 26
2	210.000.01	Cascade With Negative Polarity
	210.000.02	Cascade With Positive Polarity
	210.000.07	Cascade 9V With Negative Polarity
3	210.012.01	Lower Gun Body
4		Air Connector
5		High Voltage Supply

Internal View

Illustration 15 Internal view of an automatic gun type AG800

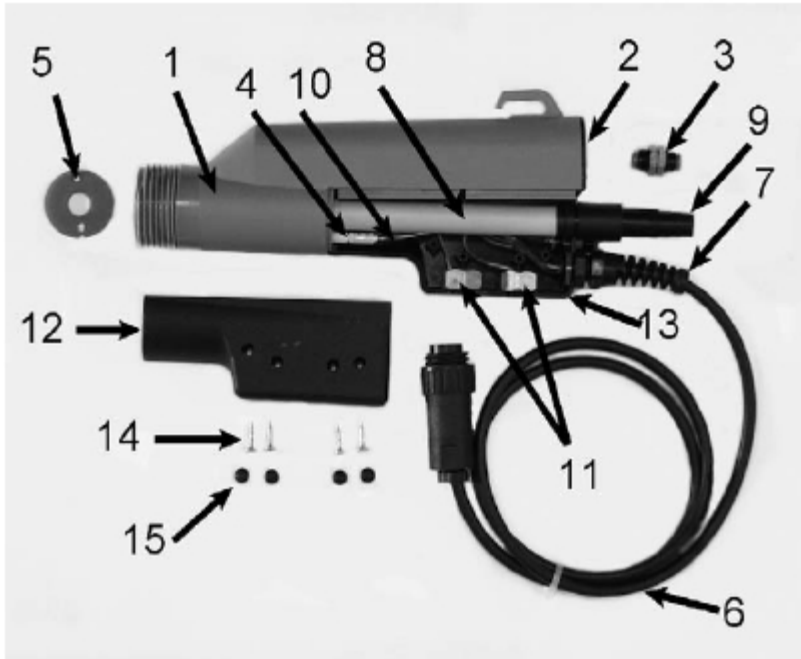

<i>Pos.in Illustration 15</i>	<i>OrderNo</i>	<i>Description</i>
1	Various	Cascade
2	20100201	CoverPlate
3	21000701	Peumatic Connector
4	20100801	Air Tube
5	20010001	Rubber Sealing
6	21000301	Cable With Plug
7	21000401	Cable Clamp
8	21000501	Powder Tube
9	21000601	Hose Connector
10	21000901	Air Hose
11	21001001	Connection Screws
12	21001101	Upper Gun Body

<i>Pos.in Illustration 15</i>	<i>OrderNo</i>	<i>Description</i>
13	21001201	Lower Gun Body
14	21001301	Fixation Screws
15	21001401	Plastic Caps