

# **GROVE**

by **Manitowoc**

## **LOAD CHARTS RT650E**

**85% STABILITY  
ON OUTRIGGERS  
75% STABILITY  
ON RUBBER**

**234250  
SERIAL NUMBER**



# TABLE OF CONTENTS

GENERAL NOTES .....	4
WEIGHT REDUCTIONS / LINE PULLS & REEVING INFO.....	5
LIFTING AREA DIAGRAMS .....	6
RANGE DIAGRAM.....	7
<b>ON OUTRIGGERS FULLY EXTENDED</b>	
MAIN BOOM .....	8
EXTENSION .....	9
ON A BARGE (Up to 5° list) .....	10
<b>ON OUTRIGGERS 50% EXTENDED</b>	
MAIN BOOM .....	11
EXTENSION .....	12
<b>ON OUTRIGGERS 0% EXTENDED</b>	
MAIN BOOM .....	13
<b>ON RUBBER .....</b>	<b>14-15</b>
TIRE INFLATION.....	16

# NOTES FOR LIFTING CAPACITIES

## GENERAL:

1. Rated loads as shown on lift chart pertain to this machine as originally manufactured and equipped. Modifications to the machine or use of optional equipment other than that specified can result in a reduction of capacity.
2. Construction equipment can be hazardous if improperly operated or maintained. Operation and maintenance of this machine shall be in compliance with the information in the Operator's and Safety Handbook, Service Manual and Parts Manual supplied with this machine. If these manuals are missing, order replacements from the manufacturer through the distributor.
3. The operator and other personnel associated with machine shall fully acquaint themselves with the latest American National Safety Standards (ASME/ANSI) for cranes.

## SETUP:

1. The machine shall be level and on a firm supporting surface. Depending on the nature of the supporting surface, it may be necessary to have structural supports under the outrigger floats or tires to spread the load to a larger bearing surface.
2. For outrigger operation, all outriggers shall be properly extended with tires raised free of crane weight before operating the boom or lifting loads.
3. When machine is equipped with center front stabilizer, the front stabilizer shall be set in accordance with instructions in Operator's and Safety Handbook.
4. When equipped with removable and/or extendible counterweight, the proper counterweight shall be installed and fully extended before and during operation.
5. Tires shall be inflated to the recommended pressure before lifting on rubber.
6. With certain boom and hoist tackle combinations, maximum capacities may not be obtainable with standard cable lengths.
7. Unless approved by the crane manufacturer, do not travel with boom extension or jib erected unless otherwise noted. Refer to Operator's and Safety Handbook for job-site travel information.

## OPERATION:

1. Rated loads at rated radius shall not be exceeded. Do not attempt to tip the machine to determine allowable loads. For clamshell, grapple, magnet or concrete bucket operation, weight of component and load must not exceed 80% of rated lifting capacities.
2. All rated loads have been tested to and meet the requirements of SAE J1063 - Cantilevered Boom Crane Structures - Method of Test, and do not exceed 85% of the tipping load on outriggers fully extended and SAE J1289 - Mobile Crane Stability Ratings [ $1.25P < (T-0.1A)$ ] on outriggers 50% and 0% extended (fully retracted) as determined by SAE J765 - Crane Stability Test Code.
3. Rated loads include the weight of hookblock, slings and auxiliary lifting devices and their weights shall be subtracted from the listed rating to obtain the net load to be lifted. When more than the minimum required parts of line needed to pick the load are used, the additional rope weight as measured from the lower sheaves of the the main boom nose shall be considered part of the load to be lifted. When both the hook block and headache ball are reeved, the lifting device that is NOT in use, including the line as measured from the lower sheave(s) of the nose supporting the unused device shall be considered part of the load.
4. Load ratings are based on freely suspended loads. No attempt shall be made to move a load horizontally on the ground in any direction.
5. The maximum in-service wind speed is 20 m.p.h. It is recommended when wind velocity is above 20 m.p.h., rated loads and boom lengths shall be appropriately reduced. For machines not in-service, the main boom should be retracted and lowered with the swing brake set in wind velocities over 30 m.p.h.
6. Rated loads are for lift crane service only.
7. Do not operate at a radius or boom length where capacities are not listed. At these positions, the machine may overturn without any load on the hook.
8. The maximum load which can be telescoped is not definable because of variations in loadings and crane maintenance, but it is safe to attempt retraction and extension of the boom within the limits of the capacity chart.
9. When the boom length or lift radius or both are between values listed, the smallest load shown at either the next larger radius or next longer or shorter boom length shall be used.
10. For safe operation, the user shall make due allowances for his particular job conditions, such as: soft or uneven ground, out of level conditions, high winds, side loads, pendulum action, jerking or sudden stopping of loads, experience of personnel, two machine (tandem) lifts, traveling with loads, electric wires, obstacles, hazardous conditions, etc. Side pull on boom or jib is extremely dangerous.
11. If machine is equipped with individually controlled powered boom sections, the boom sections must be extended equally at all times.
12. Never handle personnel with this machine unless the requirements of the applicable national, state, and local regulations and safety codes are met.
13. Keep load handling devices a minimum of 42 inches below boom head at all times.
14. The boom angle before loading should be greater than the loaded boom angle to account for deflection.
15. Capacities appearing above the bold line are based on structural strength and tipping should not be relied upon as a capacity limitation.
16. Capacities for the 33 ft. boom length shall be lifted with boom fully retracted. If boom is not fully retracted, capacities shall not exceed those shown for the 40 ft. boom length.
17. When operating the machine in the "On Outriggers 50% Extended (16' spread)" mode, the outrigger beam pins must be engaged. When operating in the "On Outriggers 0% Extended (9' 5.5" spread)" mode, the outrigger beams must be fully retracted. Failure to follow these precautions could result in structural damage or loss of stability of the machine.
18. Regardless of counterweight and outrigger spread configuration, no deduct is required from the main boom charts for a stowed boom extension.
19. Do not lift loads when boom is fully lowered. The Rated Capacity Limiter (RCL) senses pressure and will not provide warnings or lockout. The crane can become overloaded if lift cylinder(s) is fully retracted.
20. The maximum outrigger pad load is 69,100 lb.

## DEFINITIONS:

1. Operating Radius: Horizontal distance from a projection of the axis of rotation to the supporting surface before loading to the center of the vertical hoist line or tackle with load applied.
2. Loaded Boom Angle (Shown in Parenthesis on Main Boom Capacity Chart): is the angle between the boom base section and the horizontal, after lifting the rated load at the rated radius with the rated boom length.
3. Working Area: Areas measured in a circular arc about the center line of rotation as shown on the working area diagram.
4. Freely Suspended Load: Load hanging free with no direct external force applied except by the lift cable.
5. Side Load: Horizontal force applied to the lifted load either on the ground or in the air.

## WEIGHT REDUCTIONS FOR LOAD HANDLING DEVICES

<b>29 FT. OFFSETTABLE BOOM EXTENSION</b>	
*Erected -	4,412 lb
<b>29 FT. - 51 FT. TELE. BOOM EXTENSION</b>	
*Erected (retracted) -	6,611 lb
*Erected (extended) -	9,332 lb

\*Reduction of main boom capacities

AUXILIARY BOOM NOSE	137 lb
HOOKBLOCKS and HEADACHE BALLS:	
50 ton, 4 sheave	1075 lb+
50 ton, 3 sheave	1000 lb+
40 ton, 3 sheave	800 lb+
8.3 ton headache ball (non-swivel)	350 lb+
8.3 ton headache ball (swivel)	370 lb+

+Refer to rating plate for actual weight.

When lifting over swingaway and/or jib combinations, deduct total weight of all load handling devices reeved over main boom nose directly from swingaway or jib capacity.

**NOTE:** All load handling devices and boom attachments are considered part of the load and suitable allowances **MUST BE MADE** for their combined weights. Weights are for Grove furnished equipment.

## LINE PULLS AND REEVING INFORMATION

HOISTS	CABLE SPECS.	PERMISSIBLE LINE PULLS	NOMINAL CABLE LENGTH
Main	3/4" (19 mm) 6x37 Class EIPS, IWRC Special Flexible Min. Breaking Strength 58,800 lb	16,800 lb*	450 ft.
Main & Aux.	3/4" (19 mm) 35x7 Class Rotation Resistant (non-rotating) Min. Breaking Strength 85,800 lb	16,800 lb*	450 ft.

The approximate weight of 3/4" wire rope is 1.5 lb/ft.

\* With certain boom and hoist tackle combinations, the allowable line pull may be limited by hoist performance. Refer to Hoist Performance table for lift planning to ensure adequate hoist performance on drum rope layer required.

## HOIST PERFORMANCE

Wire Rope Layer	Hoist Line Pulls		Drum Rope Capacity (ft.)	
	Two Speed Hoist		Layer	Total
	Low	High		
	Available lb*	Available lb*		
1	18,134	9,067	101	101
2	16,668	8,334	110	211
3	15,420	7,710	120	331
4	14,347	7,174	129	460
5	13,413	6,707	139	599
6	12,594	6,297	149	748

\*Max. lifting capacity: 6x37 and 35x7 class = 16,800 lb

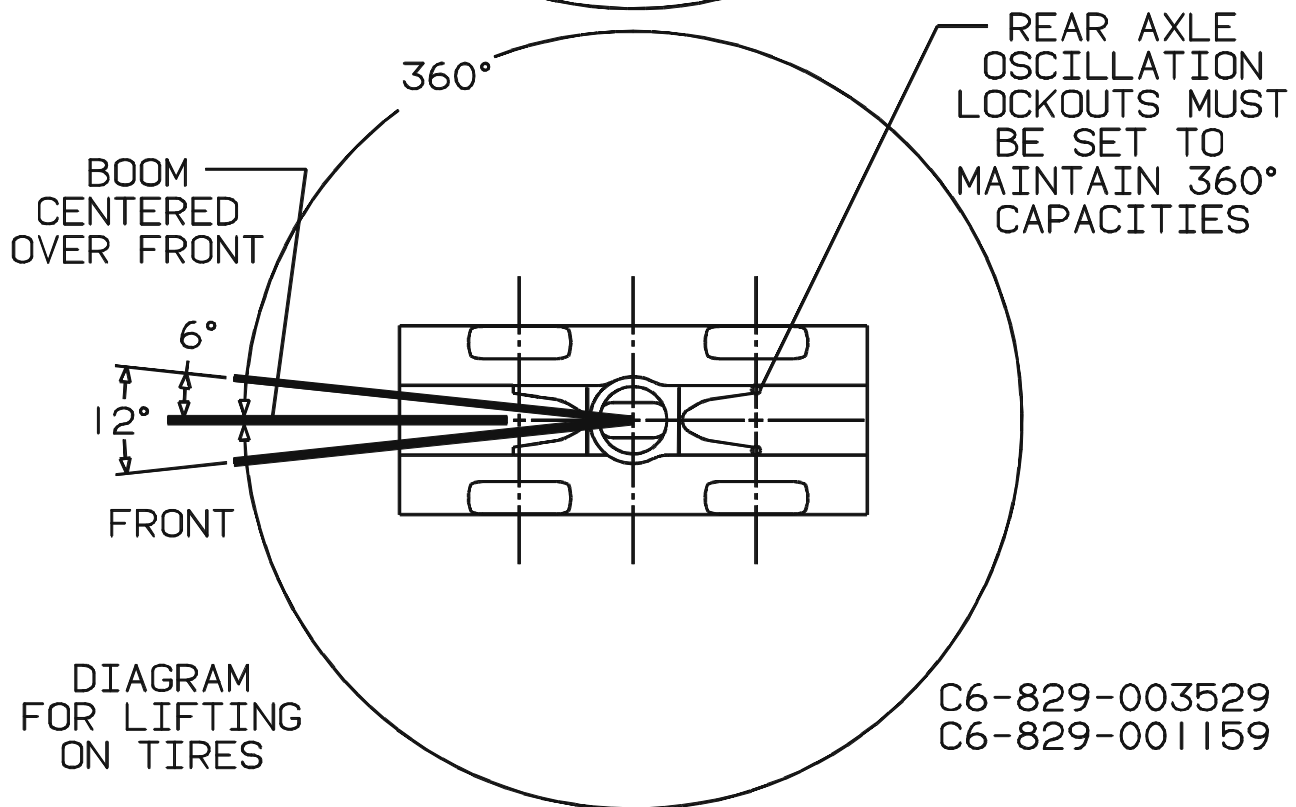
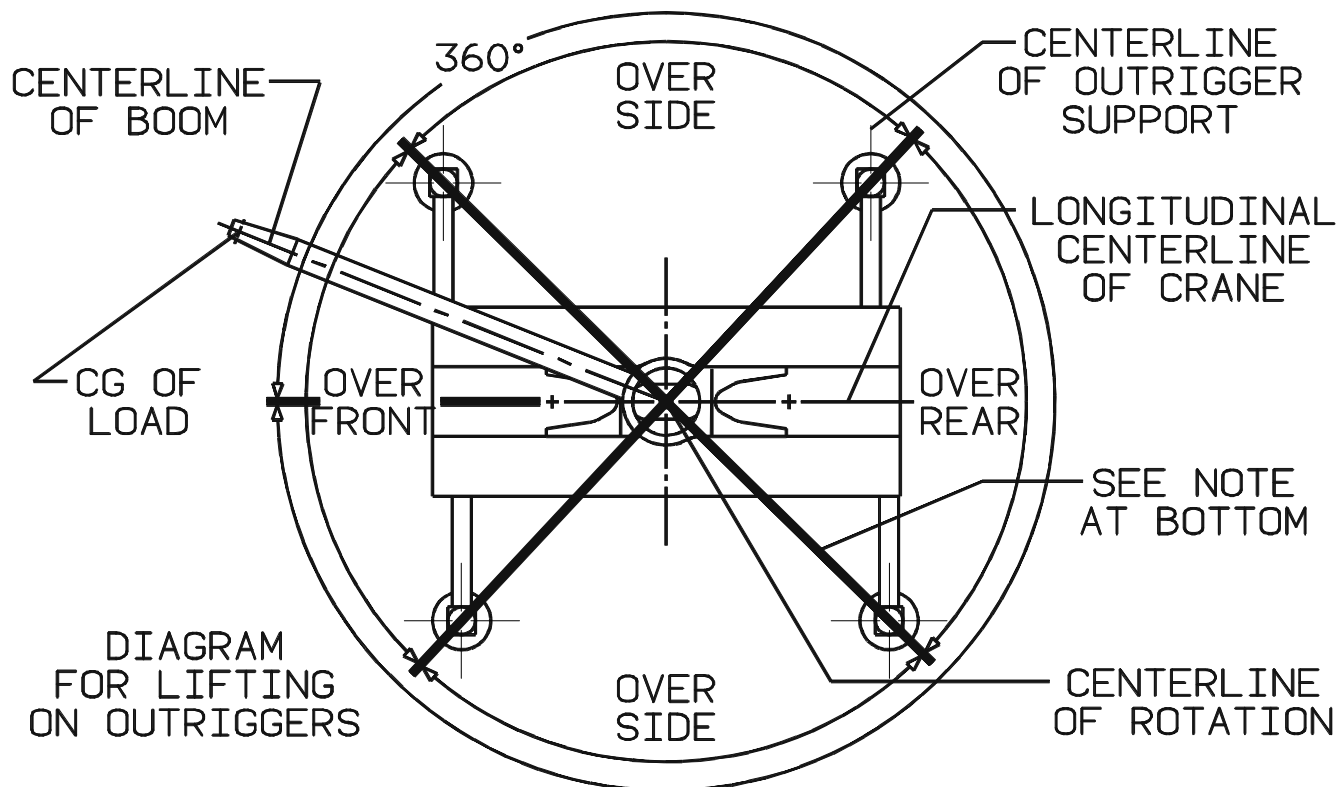

BOLD LINES DETERMINE THE LIMITING POSITION OF ANY LOAD FOR OPERATION WITHIN WORKING AREAS INDICATED

WORKING AREA DIAGRAM

# WORKING RANGE DIAGRAM

(BOOM DEFLECTION NOT SHOWN)

D6-829-100776

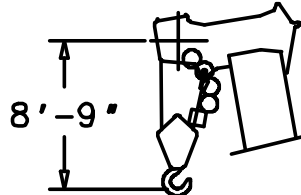
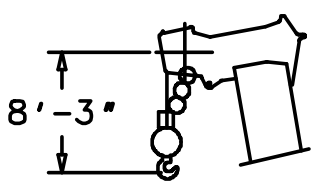
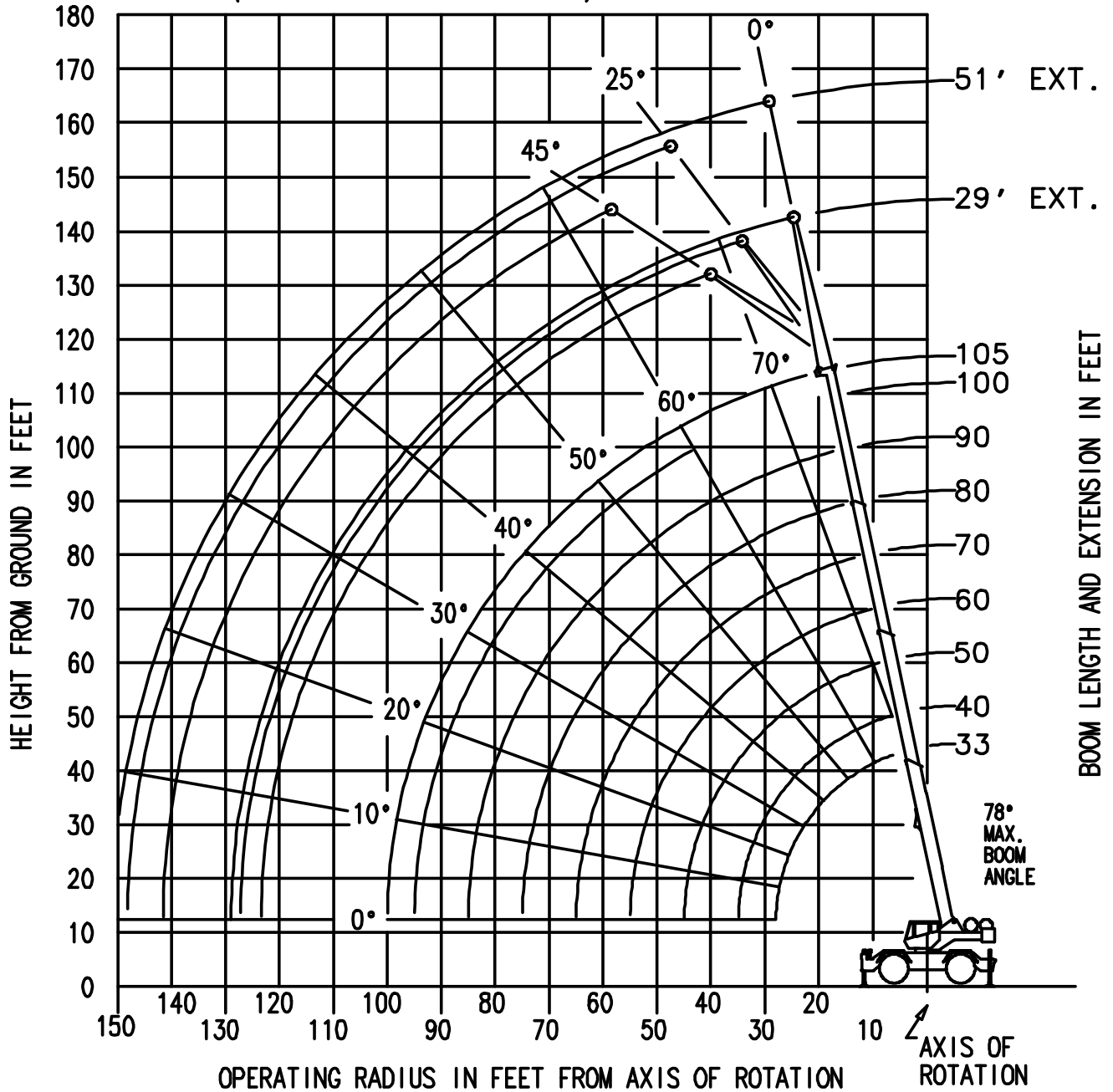

DIMENSIONS ARE FOR LARGEST GROVE FURNISHED HOOK BLOCK AND HEADACHE BALL, WITH ANTI-TWO BLOCK ACTIVATED.

**RATED LIFTING CAPACITIES IN POUNDS**  
**33 FT. - 105 FT. BOOM**  
**ON OUTRIGGERS FULLY EXTENDED - 360°**

Radius in Feet	#0001								
	Main Boom Length in Feet								
	33	40	50	60	70	80	90	100	105
10	100,000 (69.5)	80,550 (73.5)	67,250 (77)						
12	87,100 (65.5)	79,150 (70.5)	64,200 (75)	*56,100 (78)					
15	69,050 (59.5)	69,550 (65.5)	59,950 (71)	51,800 (75)	45,200 (77.5)				
20	50,500 (47.5)	50,950 (57)	51,400 (64.5)	44,500 (69.5)	38,550 (73)	34,450 (75.5)	*31,400 (78)		
25	38,300 (32)	38,850 (47)	39,350 (58)	39,650 (64.5)	37,100 (68.5)	29,850 (72)	27,250 (74.5)	21,000 (76.5)	18,350 (77.5)
30		30,700 (34.5)	31,200 (50.5)	31,500 (58.5)	31,700 (64)	26,350 (68)	24,100 (71)	21,000 (73.5)	18,350 (74.5)
35			25,450 (41.5)	25,750 (52.5)	26,000 (59)	23,650 (64)	21,500 (67.5)	19,150 (70)	18,350 (71.5)
40	See Note 16		20,850 (30.5)	21,200 (46)	21,600 (54)	21,350 (59.5)	19,400 (64)	16,650 (67)	17,300 (68.5)
45				17,100 (38)	17,350 (48.5)	17,300 (55)	17,300 (60)	14,650 (64)	15,750 (65.5)
50				13,950 (28)	14,150 (42.5)	14,200 (50.5)	14,200 (56)	13,000 (60.5)	14,300 (62.5)
55					11,700 (35)	11,750 (45.5)	11,850 (52)	11,900 (57)	12,000 (59)
60					9,730 (26)	9,870 (39.5)	9,980 (47.5)	10,100 (53.5)	10,150 (55.5)
65						8,300 (33)	8,440 (42.5)	8,600 (49.5)	8,680 (52)
70						6,960 (24.5)	7,170 (37.5)	7,340 (45.5)	7,430 (48.5)
75							6,080 (31)	6,290 (40.5)	6,390 (44.5)
80							5,130 (23)	5,380 (35.5)	5,490 (40)
85								4,580 (29.5)	4,720 (35)
90								3,880 (22)	4,020 (29)
95									3,400 (21.5)
Minimum boom angle (°) for indicated length (no load)									0
Maximum boom length (ft.) at 0° boom angle (no load)									105

NOTE: ( ) Boom angles are in degrees.  
#RCL operating code. Refer to RCL manual for operating instructions.  
\*This capacity is based on maximum boom angle.

<b>Lifting Capacities at Zero Degree Boom Angle On Outriggers Fully Extended - 360°</b>									
Boom Angle	Main Boom Length in Feet								
	33	40	50	60	70	80	90	100	
0°	16,250 (28.2)	12,500 (35)	8,780 (45)	6,290 (55)	4,510 (65)	3,160 (75)	2,110 (85)	1,260 (95)	

NOTE: ( ) Reference radii in feet.

A6-829-100936



## 29 FT. - 51 FT. TELE OFFSETTABLE BOOM EXTENSION ON OUTRIGGERS FULLY EXTENDED - 360°

Radius in Feet	**29 ft. LENGTH			51 ft. LENGTH		
	#0021	#0022	#0023	#0041	#0042	#0043
	0° OFFSET	25° OFFSET	45° OFFSET	0° OFFSET	25° OFFSET	45° OFFSET
30	*9,000 (78)					
35	9,000 (77)			*6,000 (78)		
40	9,000 (74.5)	8,000 (77.5)		6,000 (77)		
45	9,000 (72.5)	7,560 (76)	*5,660 (78)	6,000 (76)		
50	8,760 (70)	7,170 (74)	5,600 (76)	6,000 (74)		
55	8,030 (67.5)	6,820 (71.5)	5,500 (73.5)	6,000 (72)	*4,120 (78)	
60	7,380 (65)	6,500 (69)	5,300 (71)	6,000 (70)	3,900 (77)	
65	6,770 (62.5)	6,210 (66.5)	5,180 (68.5)	6,000 (68)	3,710 (75)	*2,740 (78)
70	6,210 (60)	5,950 (64)	4,890 (66)	5,620 (66)	3,530 (72.5)	2,660 (76.5)
75	5,710 (57.5)	5,710 (61.5)	4,620 (63)	5,210 (64)	3,370 (70.5)	2,580 (74)
80	5,250 (55)	5,500 (58.5)	4,370 (60.5)	4,860 (61.5)	3,220 (68.5)	2,520 (72)
85	4,790 (52)	5,300 (56)	4,100 (57.5)	4,540 (59.5)	3,080 (66)	2,460 (69.5)
90	4,090 (49)	4,650 (53)	3,820 (54)	4,260 (57)	2,960 (63.5)	2,410 (67)
95	3,480 (46)	3,960 (49.5)		4,000 (55)	2,850 (61.5)	2,360 (64.5)
100	2,930 (42.5)	3,350 (46)		3,770 (52.5)	2,750 (59)	2,330 (62)
105	2,440 (39)	2,810 (42.5)		3,360 (50)	2,660 (56)	2,300 (59)
110	2,000 (35)	2,320 (38.5)		2,910 (47.5)	2,570 (53.5)	2,280 (56)
115	1,610 (30.5)			2,500 (44.5)	2,500 (50.5)	
120	1,250 (25.5)			2,120 (41.5)	2,430 (47.5)	
125				1,780 (38.5)	2,250 (44.5)	
130				1,470 (35)	1,820 (40.5)	
135				1,180 (31)	1,420 (36.5)	
Min. boom angle for indicated length (no load)	24°	32°	45°	25°	35°	45°
Max. boom length at 0° boom angle (no load)	90 ft.			90 ft.		

### NOTES:

1. All capacities above the bold line are based on structural strength of boom extension.
2. 29 ft. and 51 ft. boom extension lengths may be used for single line lifting service.
3. Radii listed are for a fully extended boom with the boom extension erected. For main boom lengths less than fully extended, the rated loads are determined by boom angle. Use only the column which corresponds to the boom extension length and offset for which the machine is configured. For boom angles not shown, use the rating of the next lower boom angle.  
  
**WARNING:** Operation of this machine with heavier loads than the capacities listed is strictly prohibited. Machine tipping with boom extension occurs rapidly and without advance warning.
4. Boom angle is the angle above or below horizontal of the longitudinal axis of the boom base section after lifting rated load.
5. Capacities listed are with outriggers fully extended and vertical jacks set only.

NOTE: ( ) Boom angles are in degrees.

A6-829-100845A

#RCL operating code. Refer to RCL manual for instructions.

\*This capacity based on maximum boom angle.

\*\*29 ft. capacities are also applicable to fixed offsettable ext. However, the RCL code will change to #0051, #0052 and #0053 for 0°, 25° and 45° offset, respectively.

**RATED LIFTING CAPACITIES IN POUNDS ON A BARGE UP TO 5° LIST  
ON OUTRIGGERS FULLY EXTENDED - 360° (SUBJECT TO WAVE ACTION)**

Radius in Feet	#0030								
	Main Boom Length in Feet								
	33	40	50	60	70	80	90	100	105
10	50,000 (69.5)	40,270 (73.5)	33,620 (77)						
12	43,550 (65.5)	39,570 (70.5)	32,100 (75)	*28,050 (78)					
15	34,500 (59.5)	34,770 (65.5)	29,970 (71)	25,900 (75)	22,600 (77.5)				
20	25,250 (47.5)	25,450 (57)	25,700 (64.5)	22,250 (69.5)	19,250 (73)	17,200 (75.5)	*15,700 (78)		
25	19,150 (32)	19,400 (47)	19,650 (58)	19,800 (64.5)	18,550 (68.5)	14,900 (72)	13,600 (74.5)	10,500 (76.5)	9,180 (77.5)
30		15,350 (34.5)	15,600 (50.5)	15,750 (58.5)	15,850 (64)	13,150 (68)	12,050 (71)	10,500 (73.5)	9,180 (74.5)
35			12,700 (41.5)	12,900 (52.5)	13,000 (59)	11,800 (64)	10,750 (67.5)	9,590 (70)	9,180 (71.5)
40			10,600 (30.5)	10,750 (46)	10,850 (54)	10,650 (59.5)	9,710 (64)	8,340 (67)	8,660 (68.5)
45				9,120 (38)	9,220 (48.5)	9,290 (55)	8,830 (60)	7,340 (64)	7,870 (65.5)
50				7,810 (28)	7,910 (42.5)	7,980 (50.5)	8,030 (56)	6,510 (60.5)	7,200 (62.5)
55					6,840 (35)	6,910 (45.5)	6,960 (52)	5,960 (57)	6,630 (59)
60					5,950 (26)	6,020 (39.5)	6,070 (47.5)	5,350 (53.5)	6,120 (55.5)
65						5,270 (33)	5,320 (42.5)	4,830 (49.5)	5,370 (52)
70						5,270 (24.5)	5,320 (37.5)	4,380 (45.5)	5,370 (48.5)
75							4,770 (31)	3,980 (40.5)	5,010 (44.5)
80							4,020 (23)	3,980 (35.5)	4,310 (40)
85								3,590 (29.5)	3,700 (35)
90								3,040 (22)	3,150 (29)
95									2,670 (21.5)
Minimum boom angle (°) for indicated length (no load)									0
Maximum boom length (ft.) at 0° boom angle (no load)									105

NOTE: ( ) Boom angles are in degrees.  
 #LMI operating code. Refer to LMI manual for operating instructions.  
 \*This capacity is based on maximum boom angle.

Lifting Capacities at Zero Degree Boom Angle									
Boom Angle	Main Boom Length in Feet								
	33	40	50	60	70	80	90		
0°	8,140 (28.2)	6,250 (35)	4,390 (45)	3,140 (55)	2,250 (65)	1,580 (75)	1,050 (85)		

NOTE: ( ) Reference radii in feet.

80043431

Notes: Capacities are in pounds and do not exceed 66 2/3% of tipping loads as determined by test in accordance with SAE J765. Outriggers shall be completely extended and set. Machine shall be positively secured to prevent shifting. For use of a barge mounted crane, the crane shall be installed, inspected, tested, maintained and safely operated in accordance with ASME B30.8.

**RATED LIFTING CAPACITIES IN POUNDS  
33 FT. - 105 FT. BOOM**

**ON OUTRIGGERS 50% EXTENDED (16 ft. spread) - 360°**

Radius in Feet	#4001								
	Main Boom Length in Feet								
	33	40	50	60	70	80	90	100	105
10	80,000 (69.5)	73,500 (73.5)	67,200 (77)						
12	77,750 (65.5)	69,500 (70.5)	62,300 (75)	*56,100 (78)					
15	67,300 (59.5)	65,550 (65.5)	57,300 (71)	51,800 (75)	45,200 (77.5)				
20	39,400 (47.5)	39,550 (57)	39,950 (64.5)	39,500 (69.5)	38,050 (73)	34,450 (75.5)	*31,400 (78)		
25	25,700 (32)	25,850 (47)	26,200 (58)	26,650 (64.5)	27,200 (68.5)	26,800 (72)	26,050 (74.5)	21,000 (76.5)	18,350 (77.5)
30		18,350 (34.5)	18,700 (50.5)	19,150 (58.5)	19,650 (64)	19,700 (68)	19,800 (71)	19,600 (73.5)	18,350 (74.5)
35			14,000 (41.5)	14,400 (52.5)	14,900 (59)	14,950 (64)	15,000 (67.5)	15,100 (70)	15,150 (71.5)
40	See Note 16		10,750 (30.5)	11,150 (46)	11,600 (54)	11,650 (59.5)	11,700 (64)	11,800 (67)	11,800 (68.5)
45				8,800 (38)	9,240 (48.5)	9,270 (55)	9,330 (60)	9,390 (64)	9,420 (65.5)
50				6,960 (28)	7,420 (42.5)	7,450 (50.5)	7,500 (56)	7,550 (60.5)	7,580 (62.5)
55					5,990 (35)	6,010 (45.5)	6,050 (52)	6,100 (57)	6,130 (59)
60					4,800 (26)	4,850 (39.5)	4,890 (47.5)	4,930 (53.5)	4,960 (55.5)
65						3,900 (33)	3,930 (42.5)	3,970 (49.5)	3,990 (52)
70						3,060 (24.5)	3,120 (37.5)	3,160 (45.5)	3,180 (48.5)
75							2,430 (31)	2,470 (40.5)	2,490 (44.5)
80							1,810 (23)	1,880 (35.5)	1,900 (40)
85								1,350 (29.5)	1,380 (35)
0.1A (lb)	820	790	750	730	720	710	700	700	700
Minimum boom angle (°) for indicated length (no load)									0
Maximum boom length (ft.) at 0° boom angle (no load)									105

NOTE: ( ) Boom angles are in degrees.

#RCL operating code. Refer to RCL manual for operating instructions.

\*This capacity is based on maximum boom angle.

<b>Lifting Capacities at Zero Degree Boom Angle On Outriggers 50% Extended - 360°</b>									
Boom Angle	Main Boom Length in Feet								
	33	40	50	60	70	80	90		
0°	16,250 (28.2)	12,500 (35)	8,280 (45)	5,460 (55)	3,800 (65)	2,340 (75)	1,270 (85)		

NOTE: ( ) Reference radii in feet.

A6-829-100833A

## 29 FT. - 51 FT. TELE BOOM EXTENSION

ON OUTRIGGERS 50% EXTENDED (16 ft. spread) - 360°

Radius in Feet	**29 ft. LENGTH			51 ft. LENGTH		
	#4021	#4022	#4023	#4041	#4042	#4043
	0° OFFSET	25° OFFSET	45° OFFSET	0° OFFSET	25° OFFSET	45° OFFSET
30	*9,000 (78)					
35	9,000 (77)			*6,000 (78)		
40	9,000 (74.5)	8,000 (77.5)		6,000 (77)		
45	9,000 (72.5)	7,560 (76)	*5,660 (78)	6,000 (76)		
50	7,870 (70)	7,170 (74)	5,600 (76)	6,000 (74)		
55	6,530 (67.5)	6,820 (71.5)	5,500 (73.5)	6,000 (72)	*4,120 (78)	
60	5,410 (65)	6,320 (69)	5,300 (71)	6,000 (70)	3,900 (77)	
65	4,380 (62.5)	5,260 (66.5)	5,180 (68.5)	5,260 (68)	3,710 (75)	*2,740 (78)
70	3,490 (60)	4,260 (64)	4,810 (66)	4,460 (66)	3,530 (72.5)	2,660 (76.5)
75	2,730 (57.5)	3,410 (61.5)	3,880 (63)	3,770 (64)	3,370 (70.5)	2,580 (74)
80	2,070 (55)	2,670 (58.5)	3,050 (60.5)	3,140 (61.5)	3,220 (68.5)	2,520 (72)
85	1,500 (52)	2,030 (56)	2,330 (57.5)	2,550 (59.5)	3,080 (66)	2,460 (69.5)
90	1,000 (49)	1,470 (53)	1,700 (54)	2,030 (57)	2,960 (63.5)	2,410 (67)
95				1,570 (55)	2,500 (61.5)	2,360 (64.5)
100				1,160 (52.5)	1,980 (59)	2,330 (62)
105					1,510 (56)	1,840 (59)
110					1,080 (53.5)	1,320 (56)
0.1A	740	690	660	650	600	560
Min. boom angle for indicated length (no load)	42°	43°	53°	45°	46°	55°
Max. boom length at 0° boom angle (no load)	80 ft.			70 ft.		

### NOTES:

1. All capacities above the bold line are based on structural strength of boom extension.
2. 29 ft. and 51 ft. boom extension lengths may be used for single line lifting service.
3. Radii listed are for a fully extended boom with the boom extension erected. For main boom lengths less than fully extended, the rated loads are determined by boom angle. Use only the column which corresponds to the boom extension length and offset for which the machine is configured. For boom angles not shown, use the rating of the next lower boom angle.
 

**WARNING:** Operation of this machine with heavier loads than the capacities listed is strictly prohibited. Machine tipping with boom extension occurs rapidly and without advance warning.
4. Boom angle is the angle above or below horizontal of the longitudinal axis of the boom base section after lifting rated load.
5. Capacities listed are with outriggers properly extended and vertical jacks set only.

NOTE: ( ) Boom angles are in degrees.

A6-829-100846A

#RCL operating code. Refer to RCL manual for instructions.

\*This capacity based on maximum boom angle.

\*\*29 ft. capacities are also applicable to fixed offsettable ext. However, the RCL codes will change to #4051, #4052 and #4053 for 0°, 25° and 45° offset, respectively.

**RATED LIFTING CAPACITIES IN POUNDS  
33 FT. - 105 FT. BOOM**

ON OUTRIGGERS 0% EXTENDED (9 ft. 5.5 in. spread) - 360°

Radius in Feet	#8001								
	Main Boom Length in Feet								
	33	40	50	60	70	80	90	100	105
10	60,000 (69.5)	57,100 (73.5)	53,300 (77)						
12	45,850 (65.5)	44,300 (70.5)	41,850 (75)	*39,650 (78)					
15	30,700 (59.5)	30,850 (65.5)	31,100 (71)	29,750 (75)	28,500 (77.5)				
20	18,300 (47.5)	18,400 (57)	18,750 (64.5)	19,150 (69.5)	19,550 (73)	18,900 (75.5)	*18,300 (78)		
25	12,050 (32)	12,150 (47)	12,450 (58)	12,850 (64.5)	13,300 (68.5)	13,350 (72)	13,450 (74.5)	13,050 (76.5)	12,900 (77.5)
30		8,360 (34.5)	8,660 (50.5)	9,050 (58.5)	9,480 (64)	9,540 (68)	9,620 (71)	9,710 (73.5)	9,760 (74.5)
35			6,110 (41.5)	6,490 (52.5)	6,910 (59)	6,960 (64)	7,030 (67.5)	7,110 (70)	7,150 (71.5)
40	See Note 16		4,280 (30.5)	4,660 (46)	5,080 (54)	5,120 (59.5)	5,180 (64)	5,240 (67)	5,280 (68.5)
45				3,290 (38)	3,700 (48.5)	3,730 (55)	3,780 (60)	3,840 (64)	3,870 (65.5)
50				2,190 (28)	2,620 (42.5)	2,650 (50.5)	2,690 (56)	2,740 (60.5)	2,770 (62.5)
55					1,760 (35)	1,780 (45.5)	1,820 (52)	1,870 (57)	1,890 (59)
60					1,030 (26)	1,070 (39.5)	1,110 (47.5)	1,150 (53.5)	1,170 (55.5)
0.1A (lb)	820	790	750	730	720	710	700	700	700
Min. boom angle (°) for indicated length (no load)					0	24	36	44	47
Max. boom length (ft.) at 0° boom angle (no load)					70				

NOTE: ( ) Boom angles are in degrees.

#RCL operating code. Refer to RCL manual for operating instructions.

\*This capacity is based on maximum boom angle.

<b>Lifting Capacities at Zero Degree Boom Angle On Outriggers 0% Extended - 360°</b>									
Boom Angle	Main Boom Length in Feet								
	33	40	50	60					
0°	9,260 (28.2)	5,680 (35)	2,810 (45)	1,270 (55)					

NOTE: ( ) Reference radii in feet.

A6-829-100834A

# ON RUBBER CAPACITIES

## STATIONARY CAPACITIES 360°

Radius in Feet	#9005				
	Main Boom Length in Feet				
	33	40	50	60	70
10	38,550 (69.5)	38,550 (73.5)			
12	32,550 (65.5)	32,550 (70.5)	32,550 (75)		
15	23,700 (59.5)	23,700 (65.5)	23,700 (71)	23,700 (75)	
20	14,450 (47.5)	14,450 (57)	14,450 (64.5)	14,450 (69.5)	14,450 (73)
25	9,640 (32)	9,640 (47)	9,640 (58)	9,640 (64.5)	9,640 (68.5)
30		6,840 (34.5)	6,840 (50.5)	6,840 (58.5)	6,840 (64)
35			4,850 (41.5)	4,850 (52.5)	4,850 (59)
40	See Note 16		3,450 (30.5)	3,450 (46)	3,450 (54)
45				2,410 (38)	2,410 (48.5)
50				1,610 (28)	1,610 (42.5)
Min. boom angle (°) for indicated length (no load)					30
Max. boom length (ft.) at 0° boom angle (no load)					60

NOTE: ( ) Boom angles are in degrees.

#RCL operating code. Refer to RCL manual for operating instructions.

Lifting Capacities at Zero Degree Boom Angle On Rubber - 360°					
Boom Angle	Main Boom Length in Feet				
	33	40	50		
0°	7,580 (28.2)	4,850 (35)	2,410 (45)		

NOTE: ( ) Reference radii in feet.

A6-829-100836B

## STATIONARY CAPACITIES DEFINED ARC OVER FRONT (See Note 3)

Radius in Feet	#9005				
	Main Boom Length in Feet				
	33	40	50	60	70
10	46,600 (69.5)	40,800 (73.5)	34,600 (77)		
12	40,800 (65.5)	40,800 (70.5)	34,600 (75)		
15	34,000 (59.5)	34,000 (65.5)	34,000 (71)	26,650 (75)	21,500 (77.5)
20	26,050 (47.5)	26,050 (57)	26,050 (64.5)	26,050 (69.5)	21,500 (73)
25	18,200 (32)	18,200 (47)	18,200 (58)	18,200 (64.5)	18,200 (68.5)
30		13,100 (34.5)	13,100 (50.5)	13,100 (58.5)	13,100 (64)
35			10,050 (41.5)	10,050 (52.5)	10,050 (59)
40	See Note 16		7,900 (30.5)	7,900 (46)	7,900 (54)
45				6,290 (38)	6,290 (48.5)
50				5,050 (28)	5,050 (42.5)
55					4,060 (35)
60					3,260 (26)
Min. boom angle (°) for indicated length (no load)					0
Max. boom length (ft.) at 0° boom angle (no load)					70

NOTE: ( ) Boom angles are in degrees.

#RCL operating code. Refer to RCL manual for operating instructions.

Lifting Capacities at Zero Degree Boom Angle On Rubber - Defined Arc Over Front					
Boom Angle	Main Boom Length in Feet				
	33	40	50	60	70
0°	14,550 (28.2)	10,050 (35)	6,290 (45)	4,060 (55)	2,590 (65)

NOTE: ( ) Reference radii in feet.

A6-829-100835B

## ON RUBBER CAPACITIES (cont'd.)

### PICK & CARRY CAPACITIES (UP TO 2.5 MPH) - BOOM CENTERED OVER FRONT (See note 7)

Radius in Feet	#9006				
	Main Boom Length in Feet				
	33	40	50	60	70
10	30,150 (69.5)	30,150 (73.5)	17,850 (77)		
12	30,150 (65.5)	30,150 (70.5)	17,850 (75)		
15	29,650 (59.5)	29,650 (65.5)	17,850 (71)	17,850 (75)	14,750 (77.5)
20	22,650 (47.5)	22,650 (57)	17,850 (64.5)	17,850 (69.5)	14,750 (73)
25	17,850 (32)	17,850 (47)	17,850 (58)	17,850 (64.5)	14,750 (68.5)
30		13,100 (34.5)	13,100 (50.5)	13,100 (58.5)	13,100 (64)
35			10,050 (41.5)	10,050 (52.5)	10,050 (59)
40	See Note 16		7,340 (30.5)	7,340 (46)	7,340 (54)
45				6,020 (38)	6,020 (48.5)
50				4,940 (28)	4,940 (42.5)
55					4,030 (35)
60					3,260 (26)
Min. boom angle (°) for indicated length (no load)					0
Max. boom length (ft.) at 0° boom angle (no load)					70

NOTE: ( ) Boom angles are in degrees.  
#RCL operating code. Refer to RCL manual for operating instructions.

Lifting Capacities at Zero Degree Boom Angle On Rubber - Pick & Carry					
Boom Angle	Main Boom Length in Feet				
	33	40	50	60	70
0°	14,550 (28.2)	10,050 (35)	6,020 (45)	4,030 (55)	2,590 (65)

NOTE: ( ) Reference radii in feet.

A6-829-100837B

### NOTES TO ALL RUBBER CAPACITY CHARTS:

- Capacities are in pounds and do not exceed 75% of tipping loads as determined by test in accordance with SAE J765.
- Capacities are applicable to machines equipped with 23.5x25 (20 ply) tires at 85 psi cold inflation pressure.
- Defined Arc - Over front includes 6° on either side of longitudinal centerline of machine (ref. drawing C6-829-003529).
- Capacities appearing above the bold line are based on structural strength and tipping should not be relied upon as a capacity limitation.
- Capacities are applicable only with machine on firm level surface.
- On rubber lifting with boom extensions not permitted.
- For pick and carry operation, boom must be centered over front of machine, mechanical swing lock engaged and load restrained from swinging. When handling loads in the structural range with capacities close to maximum ratings, travel should be reduced to creep speeds.
- Axle lockouts must be functioning when lifting on rubber.
- All lifting depends on proper tire inflation, capacity and condition. Capacities must be reduced for lower tire inflation pressures. See lifting capacity chart for tire used. Damaged tires are hazardous to safe operation of crane.
- Creep - not over 200 ft. of movement in any 30 minute period and not exceeding 1 mph.

TIRE INFLATION - PSI (BAR)

SIZE (FRONT & REAR)	LOAD RANGE	TRA CODE	LIFTING SERVICE AND GENERAL TRAVEL	EXTENDED TRAVEL
			STATIC, CREEP & 2.5 MPH (4.0 km/h)	
23.5x25	20 PR	E-3	85 (5.9)	85 (5.9)
23.5R25 GY/Titan	**	-----	80 (5.5)	80 (5.5)
23.5R25 Michelin	*	-----	75 (5.2)	75 (5.2)