



BROAN HRV80

Part no. HRV80T (TOP PORTS)

Part no. HRV80S (SIDE PORTS)

37 to 77 CFM (0.4 in. w.g.)



VB0242

THE HRV80: PERFECTION IN A CUBE!

The HRV80 is the ideal choice for condominiums, apartments and other limited space applications that require up to 77 cfm of continuous ventilation. With its compact size and 4-inch vertical or horizontal ports, it can be installed in small spaces such as a closet or mechanical room above a hot water tank.

The HRV80 has just one blower (patent pending) and is therefore quieter than any other similar HRV on the market.

- At just 30 lb. (13.6 kg), it can be installed without opening the unit
- Features pressure taps, balancing dampers, integrated hooks and port straps to simplify installation
- Removable terminal block for quicker wall control connections
- ENERGY STAR® qualified

REPAIRS AND MAINTENANCE

All parts of the HRV80 that could need maintenance can be removed in less than five minutes, allowing direct access for easy repairs. The PSC motor is permanently lubricated.

WARRANTY

The HRV80 is protected by a 5-year warranty on parts only. The heat recovery core is covered by a limited lifetime warranty, with the original proof of purchase.

Available at:

HEAT RECOVERY VENTILATOR

Controls

- This unit is very simple to operate. Once it is installed, press on its push button, located on the unit top left side, to select high speed, low speed or to stop it (the blower is off but will turn on in response to a wall control signal). The LED (located under the push button) will then show on which mode the unit is in.
- For more convenience, this unit can also be controlled by an optional main control. For a complete list of optional main and auxiliary controls available, refer to the **Wall Control Compatibility Chart** on last pages of wall controls specification sheet, available at www.broan.com.
- For more details about controls, refer to the **Main and auxiliary wall controls** user guide, also available at www.broan.com.

Options

- Complete line of registers and diffusers
- Exclusive wall mounting bracket no. VACCWMK

Defrosting System

The HRV80 uses a unique recirculation defrost method, which maintains balanced air pressure in the home. If there is a call for ventilation from an auxiliary wall control during the defrost cycle, the defrost is put "on hold" while air is exchanged, ensuring that no humid air is recirculated.

OUTDOOR TEMPERATURE		DEFROST CYCLE MIN./ OPERATING MIN.
°C	°F	
WARMER THAN -5	WARMER THAN 23	NO DEFROST
-5 TO -15	23 TO 5	5/30
-15 TO -27	5 TO -17	5/20
-27 AND LESS	-17 AND LESS	7/15

Heat Recovery Core

Dimensions: 10" x 10" x 5.5" (25.4 cm x 25.4 cm x 14 cm)

Exchange surface: 42.3 ft.² (3.9 m²)

Weight: 4 lb. (1.8 kg)

Material: Polypropylene

Type: Cross flow

Warranty: Limited lifetime

Requirements and standards

- Complies with the UL 1812 requirements regulating the installation of Heat Recovery Ventilators
- Complies with the CSA C22.2 no. 113 Standard applicable to ventilators
- Complies with CSA C444 requirements regulating the installation of Heat Recovery Ventilators
- Technical data was obtained from published results of tests relating to CSA C439 Standards
- HVI certified and ENERGY STAR® qualified

This product earned the ENERGY STAR® by meeting strict energy efficiency guidelines set by Natural Resources Canada and the US EPA. It meets ENERGY STAR requirements only when used in Canada.

DIMENSIONS: HRV80S (SIDE PORTS)

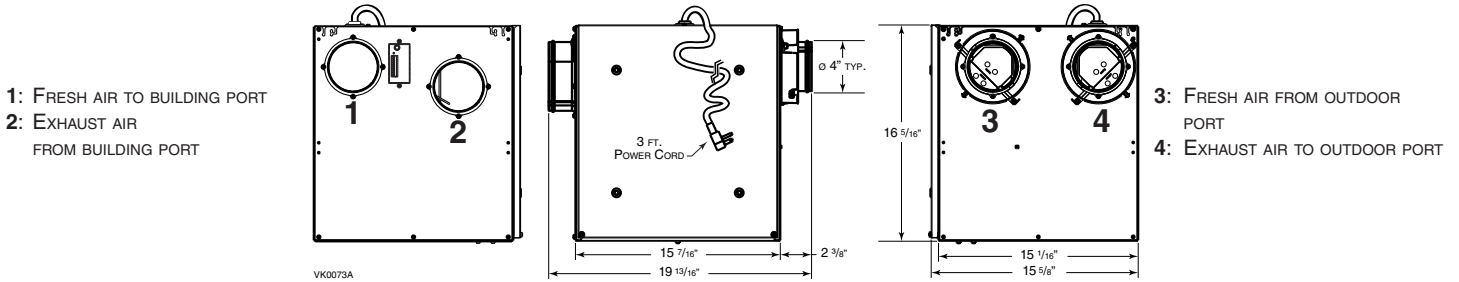

NOTE: ALL UNITS PORTS WERE CREATED TO BE CONNECTED TO DUCTS HAVING A MINIMUM OF 4" DIAMETER, BUT IF NEED BE, THEY CAN BE CONNECTED TO BIGGER SIZED DUCTS BY USING AN APPROPRIATE TRANSITION (E.G.: 4" DIAMETER TO 5" DIAMETER TRANSITION).

VENTILATION PERFORMANCE

EXTERNAL STATIC PRESSURE		NET SUPPLY AIR FLOW			GROSS AIR FLOW					
PA	IN. W.G.	L/S	CFM	M ³ /H	SUPPLY			EXHAUST		
					L/S	CFM	M ³ /H	L/S	CFM	M ³ /H
25	0.1	42	88	150	42	89	151	43	91	155
50	0.2	40	86	146	40	86	146	42	88	150
75	0.3	38	81	138	39	82	139	40	85	144
100	0.4	36	77	131	37	78	133	38	81	138
125	0.5	34	72	122	35	73	124	36	77	131
150	0.6	32	68	116	32	69	117	34	73	124
175	0.7	30	63	107	30	64	109	33	69	117
200	0.8	28	59	100	28	59	100	30	64	109

HRV80T (TOP PORTS)

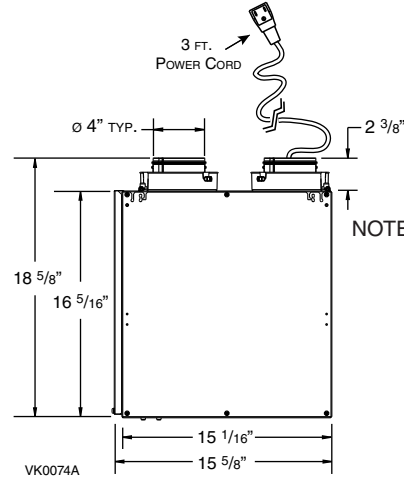
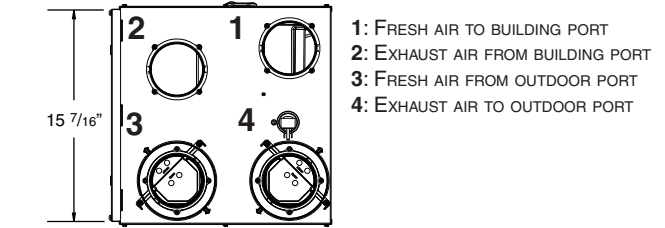

NOTE: ALL UNITS PORTS WERE CREATED TO BE CONNECTED TO DUCTS HAVING A MINIMUM OF 4" DIAMETER, BUT IF NEED BE, THEY CAN BE CONNECTED TO BIGGER SIZED DUCTS BY USING AN APPROPRIATE TRANSITION (E.G.: 4" DIAMETER TO 5" DIAMETER TRANSITION).

ENERGY PERFORMANCE

SUPPLY TEMPERATURE		NET AIR FLOW			POWER CONSUMED WATTS	SENSIBLE RECOVERY EFFICIENCY	APPARENT SENSIBLE EFFECTIVENESS	LATENT RECOVERY/MOISTURE TRANSFER
°C	°F	L/S	CFM	M ³ /H				
HEATING								
0	32	18	37	63	37	68	80	2
0	32	22	47	80	39	66	76	3
0	32	30	64	109	52	63	72	1
-25	-13	23	48	82	48	60	78	4
-25	-13	30	64	109	62	55	70	5

NOTE: All specifications are subject to change without notice.

SPECIFICATIONS

- Model: HRV80
- Part Number Top Ports: HRV80T
- Part Number Side Ports: HRV80S
- Total Assembled Weight (including polypropylene core): 30 lb. (13.6 kg)
- Round 4" ports
- Drain: 1/2" (1.2 cm) fitting with 10 ft. (3 m) PVC drain hose
- Core Filters: 2 washable foam filters, 30 ppi 9.2" x 5.75" x 0.38" (23.4 cm x 16.6 cm x 1 cm)
- Housing: Pre-painted steel
- Insulation: Expanded polystyrene
- Mounting: Suspension by chains and spring or optional wall bracket
- Supply and Exhaust Blower Motor: 1 motor
 - Protection type: Thermally protected
 - Insulation class: B
- Speed Control on Unit:
 - Low speed and high speed
 - Other modes available with optional wall controls
- Heat Recovery Core:
 - Heat Exchange Surface Area: 42.3 ft.² (3.9 m²)
 - Type: Crossflow
 - Material: Polypropylene
- Unit Electrical Characteristics:

Volts	Frequency	Ampere	Watts
120	60 Hz	0.5	60

Project:	REMARKS
Location:	
Part no.:	
Qty.:	
Submitted by:	Date:



Broan-NuTone LLC, 926 West State Street, Hartford, WI 53027 (1-877-862-7626)



www.broan.com

HRV80d161108