

SIMPLEX®

A Division Of Templeton, Kenly & Co., Inc.

**THE NEW STANDARD FOR ALL RAIL CAR MAINTENANCE
NOBODY MAKES IT EASIER, SAFER OR BETTER**

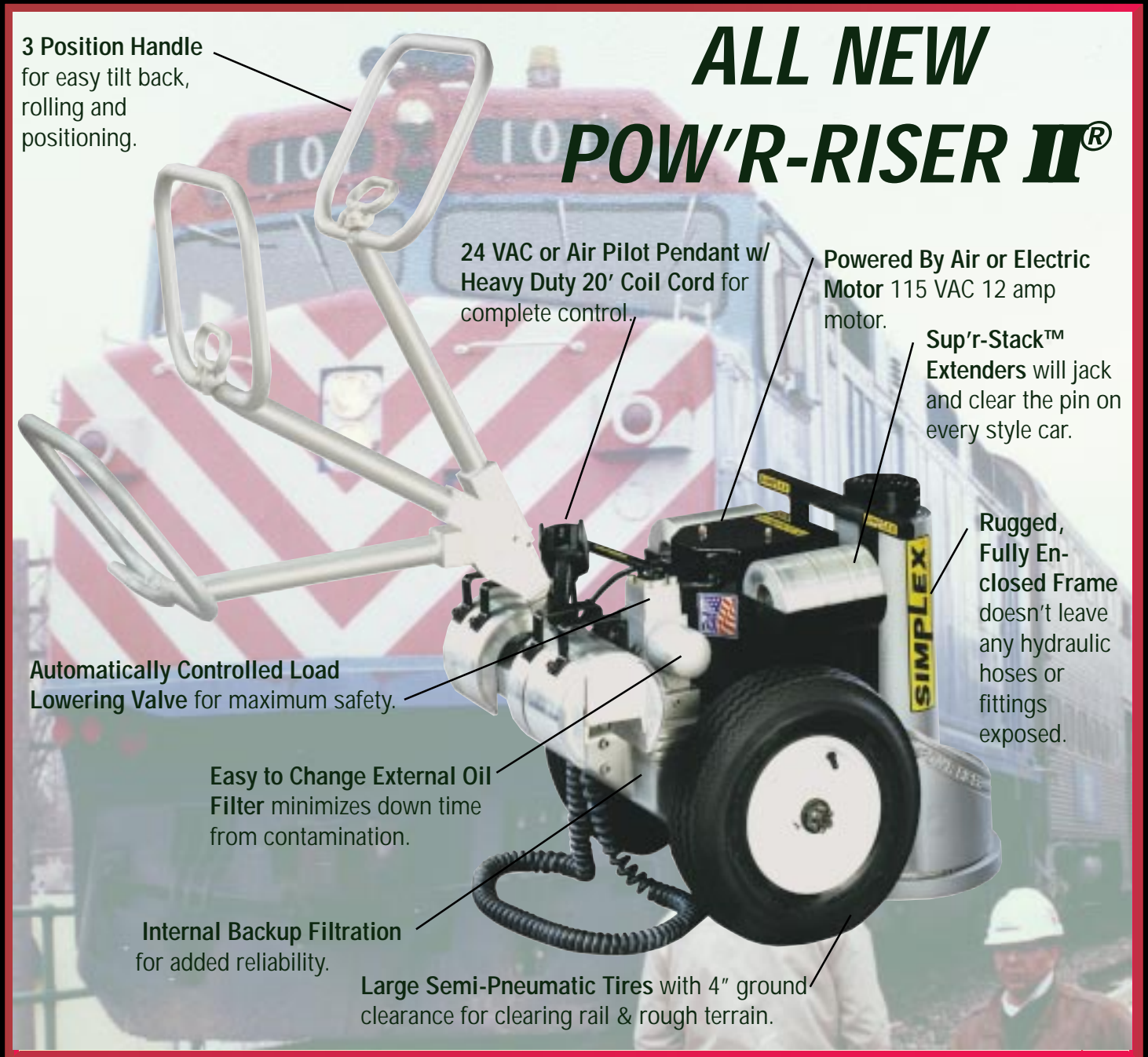

**ALL NEW
POW'R-RISER II**®

3 Position Handle for easy tilt back, rolling and positioning.

24 VAC or Air Pilot Pendant w/ Heavy Duty 20' Coil Cord for complete control.

Powered By Air or Electric Motor 115 VAC 12 amp motor.

Sup'r-Stack™ Extenders will jack and clear the pin on every style car.

Rugged, Fully Enclosed Frame doesn't leave any hydraulic hoses or fittings exposed.

Automatically Controlled Load Lowering Valve for maximum safety.

Easy to Change External Oil Filter minimizes down time from contamination.

Internal Backup Filtration for added reliability.

Large Semi-Pneumatic Tires with 4" ground clearance for clearing rail & rough terrain.

For more information and FREE Catalog Contact:



HYDRAULIC & MECHANICAL POWER

Phone: (800) 323-9114 or Fax: (708) 865-0894



POW'R-RISER II[®]

NOTHING ELSE IS EASIER:

- 24" minimum height fits under Tri-levels & Intermodal.
- 60, 100 & 150 ton capacities to handle the toughest jobs.
- Extensions allow one jack to clear the pin on every style car.
- Up to 32" of drop in extenders even handles high hoppers.
- 3 position handle for the easiest tilt back and rolling.
- 4" ground clearance for clearing rail and rough terrain.
- 25' pendant w/ heavy duty coil cord for complete control.
- Only 24" wide/fits in tight spots.



NOTHING ELSE IS SAFER:

- Dual hydraulic locking systems prevent creep down.
- Mechanical lock rings for fail safe holding.
- Lock rings and spacers can be stored on board.
- 24 volt hand held pendant for operator safety.
- Sup'r-Stack™ eliminates setting the jack up on blocks.
- Lower handle for "scooting" the jack without back strain.
- All Pow'r-Riser II[®] comply with ASME/ANSI B30.1 Specs.
- The jack can be scooted up to 5' under the load for center sill jacking.
- Equipped with a pilot-operated check valve which locks the load in place to prevent accidental lowering.

NOTHING ELSE COMES CLOSE:

- Easy to change external filter minimizes down time.
- Rugged, fully enclosed frame; no exposed fittings or hoses.
- Runs on air or 115VAC 12 amp service.
- Secondary back up filtration system for reliability.
- Light weight for greater mobility and less back strain.
- Automatically controlled, "chatter free" load lowering for maximum safety.





POW'R-RISER II®

ONE JACK FOR ALL CARS FROM INTERMODAL TO HIGH HOPPER WITH 28 DIFFERENT HEIGHTS IN BETWEEN. The Simplex JE6024 60 Ton Pow'r-Riser II, When Used With Sup'r-Stack™ Model #ES6024 Extension Set and Model #JS4 Spacer Set, Can Handle All Cars Without Blocking.

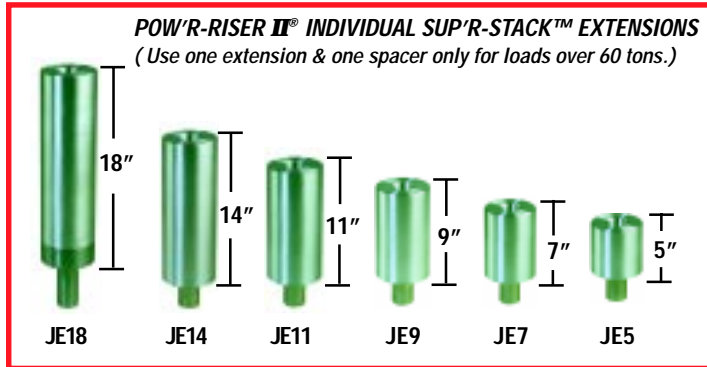

ES6024 Railcar Extension Set

Model Number	Description
JE5	5" Extender
JE7	7" Extender
JE11	11" Extender
JE18	18" Extender

Min. & Max. Height For Railcar Lifting Can Be Achieved By Using The Following Spacer/Extender Combination

Min. Height	25	26	27	29	30	31	32	33	34	35	36	37	38	40	42	43	44	45	47	48	49	50	51	52	53	54	55	56
Ext. Height	39	40	41	43	44	45	46	47	48	49	50	51	52	54	56	57	58	59	61	62	63	64	65	66	67	68	69	70
Spacer					+1		+1	+2	+3		+1	+2	+3	+5		+1	+2	+3	+5	+1	+7	+1	+2	+3	+11	+1	+2	+3
Drop-In Extender Combination	1	2	3	5	5	7	7	7	7	11	11	11	11	11	18	18	18	18	18	+5	18	+7	18	18	18	18	18	18

Use tallest extender on the bottom.

POW'R-RISER II® SPACER SET - JS4

Never exceed 3" in total spacer height.

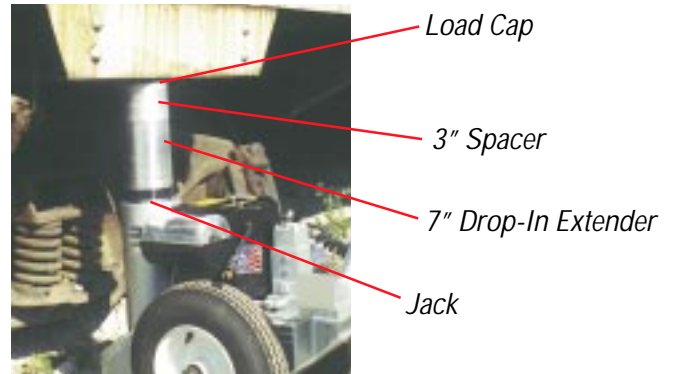

Fine tune your extension stack height by adding 1", 2" or 3" spacer.

POW'R-RISER II® LOCKING U-RING SETS



Model Number	Models Used On	Contains
JUS126	60 Ton 24"/100 Ton 26"	(2) JU11 - 1", (1) JU13 - 3", (2) JU14 - 4 1/4"
JUS137	60 Ton 37"/100 Ton 37"	(2) JU11 - 1", (1) JU13 - 3", (2) JU14 - 4 1/4", (1) JU110 - 10"
JUS1526	150 Ton 26"	(2) JU151 - 1", (1) JU153 - 3", (2) JU155 - 5 1/2"
JUS1537	150 Ton 37"	(2) JU151 - 1", (1) JU1510 - 10", (2) JU155 - 5 1/2"

Model Number	Capacity (tons)	Min. Height (in.)	Stroke (in.)	Max. Additional Stack Ht. Using Optional Extension System (in.)	Motor	Control Valve	Power Source	Noise Level (Db)	Weight (lbs.)					
JA6024	60	24	14	32*	Air	Manual	Air Motor 50 CFM 80 PSI	89	390					
JA6037		37	27	11										
JE6024***		24	14	32*	Electric		115 VAC 50/60 Hz 12 amps	80	390					
JE6037		37	27	11										
JA10026	100	26	16	21**	Air	Manual	Air Motor 50 CFM 80 PSI	89	510					
JA10037		37	27	11										
JAS10026		26	16	21**						Electric	Manual	115 VAC 50/60 Hz 12 amps	80	510
JAS10037		37	27	11										
JE10026		26	16	21**										
JE10037		37	27	11										
JEB10026		26	16	21**	Air	Remote 20' Pend.	Air Motor 50 CFM 80 PSI	89	510					
JEB10037		37	27	11										
JAS15026	150	26	15 1/2	21**						Electric	Manual	115 VAC 50/60 Hz 20 amps	80	510
JAS15037		37	26 1/2	11										
JE15026		26	15 1/2	21**										
JE15037		37	26 1/2	11										
JEB15026		26	15 1/2	21**	Air	Remote 20' Pend.	Air Motor 50 CFM 80 PSI	89	570					
JEB15037		37	26 1/2	11										
JE15026		26	15 1/2	21**										
JE15037		37	26 1/2	11										

* Based on (1) 18" and (1) 11" extension and (1) 3" spacer.

**Based on (1) 18" extension and (1) 3" spacer.

WARNING: Any two extensions may be stacked for railcar lifting. For loads over 60 tons or strokes over 14" only 1 extension and 1 spacer can be used.

*** JE6024 is ideal for most car shop work.

Model Number	"A" (in.)	"B" (in.)	"C" (in.)	"D" (in.)
JE6024	24	6.38	14	4
JE6037	37	6.38	14	
JE10026	26	7	18	4
JE10037	37	7	18	
JE15026	26	8	18	5
JE15037	37	8	18	

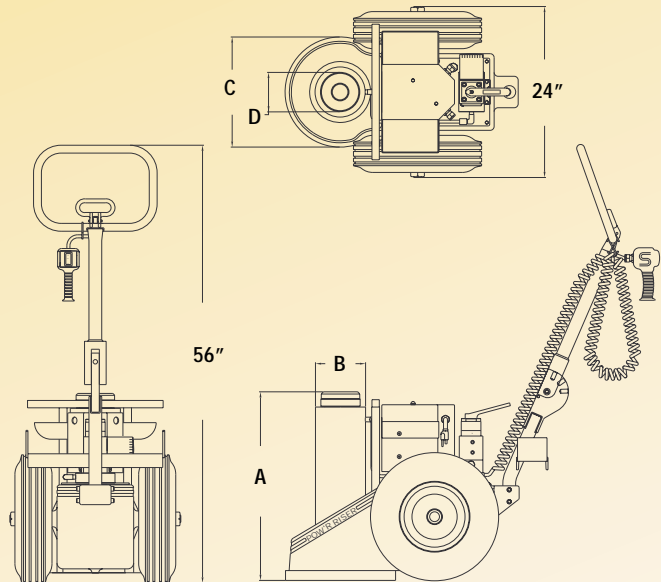

For more information and FREE Catalog Contact: