

## Design Guide – Classroom



### Classroom

A corporate classroom will be used for training, seminars, briefings and presentations. The system needs to be capable of displaying both digital and analog source types in a high quality, professional manner. The lectern/front desk will have one HDMI and one analog VGA input available to the presenter as well as a resident network PC. Inputs will be capable of supporting signals up to 4K. There will also be a preview monitor where the lecturer can preview the display before sending the content through to the main projector. In a central equipment area, there will be a TV receiver and a Blu-ray player.

Delegates can present wirelessly by accessing the Crestron AirMedia wireless gateway whilst audio is picked up from 2 ceiling microphones and sent to 4 ceiling speakers.

The room can be controlled from a single 7" Touch Panel or perhaps a larger iOS or Android tablet.

### Features

- Great quality
- High capability
- Simple user experience
- Maximise available space
- Full 4k solution
- HDCP 2.1 compliant



Crestron AirMedia offers access for 32 simultaneous devices which can be a mixture of Windows, OS X, Apple iOS or Android.

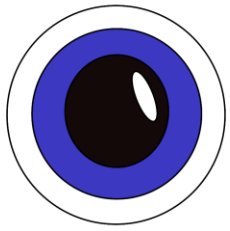

# i-Klarity Video Solutions

## Typical Schematic

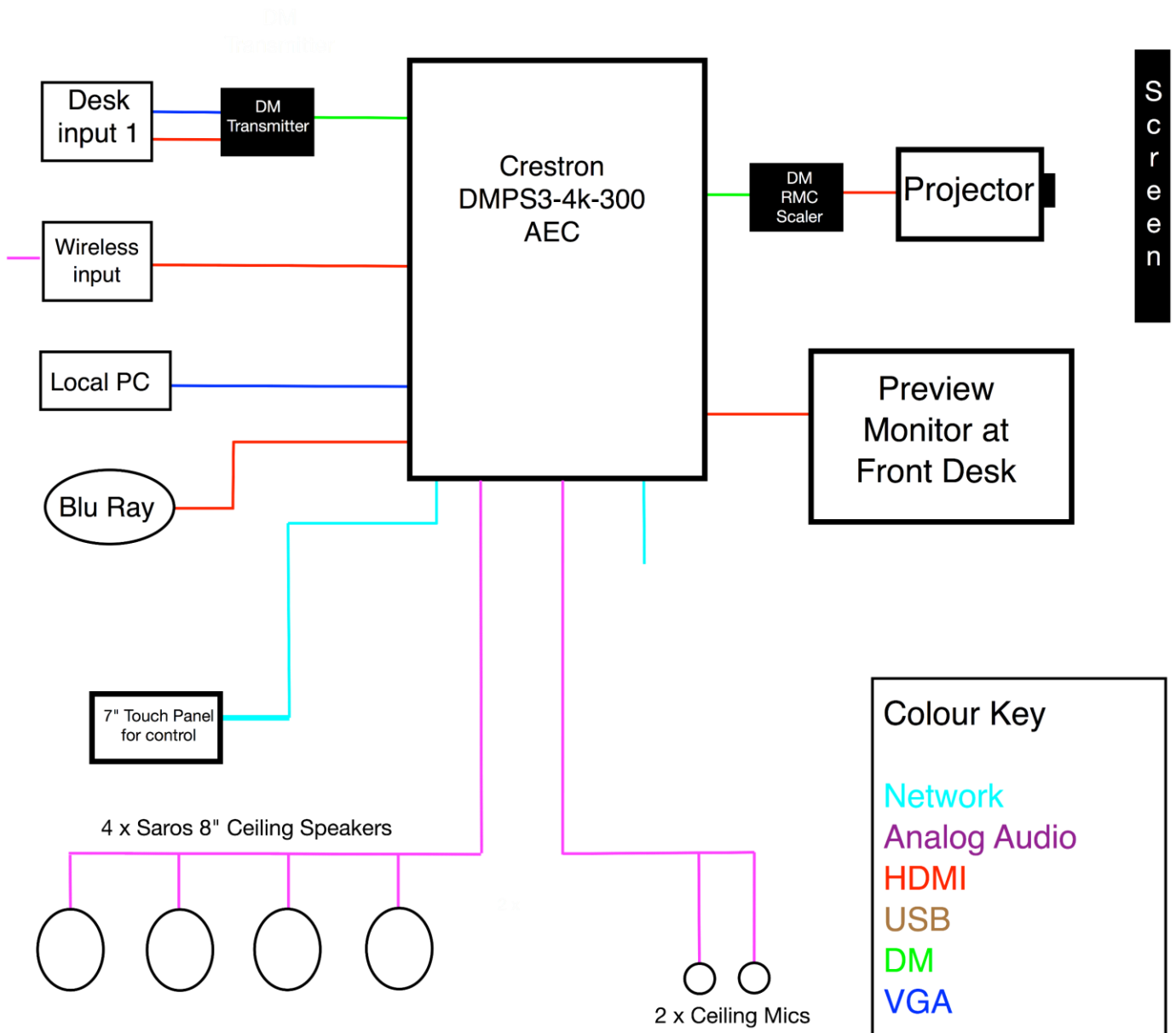

## Key Products for consideration

Crestron DMPS3-4k-300 AEC Presentation System

Crestron 7" Touch Panel

Crestron AM-101 AirMedia Wireless Gateway

Crestron Saros two-way ceiling speakers

ClearOne ceiling mics

Canon STW 4000 lumens Short Throw Projector

Euroscreen Tab-tensioned electronic display screen

For more information please visit [www.i-klarity.co.uk](http://www.i-klarity.co.uk)  
or contact [enquiries@i-klarity.co.uk](mailto:enquiries@i-klarity.co.uk).