



10 MHz Reference - Breakout PCB

Overview

The Electro-Resales 10 MHz OCXO breakout boards are available in 3 formats. The first is a fully populated PCB with OCXO, power supply, variable resistor and output BNC included. This unit is ready to use upon application of 12 VDC to the center positive 2.1 mm barrel jack and has a square wave output.

The second unit is the same module but with a low pass filter on the output to create a sine wave output. This unit is ready to use upon application of 12 VDC to the center positive 2.1 mm barrel jack and has a sine wave output.

Both units also include male and female header pins to allow you to properly access the breakout pins.

How to use both these boards is detailed below. PCB layouts and schematics are included in the appendix (A&B) along with a component list.

Complete Breakout PCB

Photo 1 shows the complete PCB in plan view; refer to this for any clarifications while reading this section.

Photo 1.

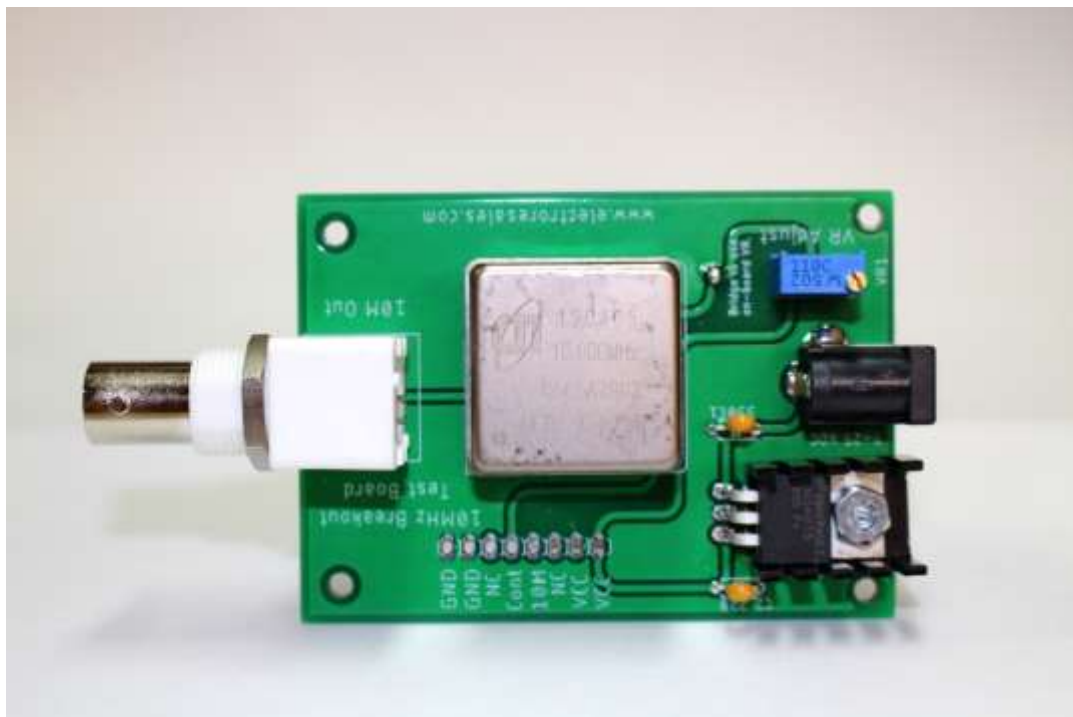



Electro-Resales LLC

Think-Design-Make

11287 S. Lake Crest Dr.

Olathe, KS. 66061

913-544-6184

- Power is applied to the 2.1mm barrel jack. This is a DC voltage between 9 and 24 VDC. The jack is center positive; use of a center negative jack/power supply will damage the board. The on board 5 volt regulator is designed to provide the drive voltage and sufficient current for the initial warm up phase (approx. 450mA) and the continuous use phase (approx. 250mA). The regulator will get warm a heatsink helps to avoid issues with overheating.
- As soon as power is applied to the PCB the 10 MHz signal is available on the BNC jack, this will be either a square or sine wave, dependent on module purchased. The actual frequency will stabilize as the warm up period ends and the oscillator starts its initial aging over the next 24 hours of use. At this point the signal is usable and while 'free running' will exhibit reasonable stability. Some drift is to be expected, in the region of;
 - 9.99999990 – 10.000000050 MHz
- If the oscillator frequency is to be controlled (disciplined) to achieve higher levels of accuracy, two methods are provisioned on the PCB, the header bank on the left side of the board, when the BNC is at the top, has a position marked 'cont' where a control voltage from an external source maybe applied (see photo 2). Alternately a 25 turn 5K Ω trimmer is installed on the PCB, which is across the supply 5 volts, with the wiper connected to the control pin of the oscillator.
- As supplied this potentiometer is not in circuit. Two small solder pads will need to be bridged (see photo 3). When this is done adjustment of the frequency can be made by making small adjustments to the trimming nut on the top of the potentiometer. Adjustments need to be small and as each adjustment can achieve a wide frequency swing a frequency counter will be needed to monitor the changes.
- If external control is envisaged, the potentiometer is left out of circuit and the solder pads left unbridged.

Photo 2.



The complete PCB is ready to use when power is applied and the previous notes assume you will either leave the board free running or integrate it in to a more sophisticated, disciplined arrangement. Exact details on how to complete a disciplined unit are beyond this user note, but plenty of information on this subject is available online.



Electro-Resales LLC
Think-Design-Make

11287 S. Lake Crest Dr.
Olathe, KS. 66061
913-544-6184

Photo 3.

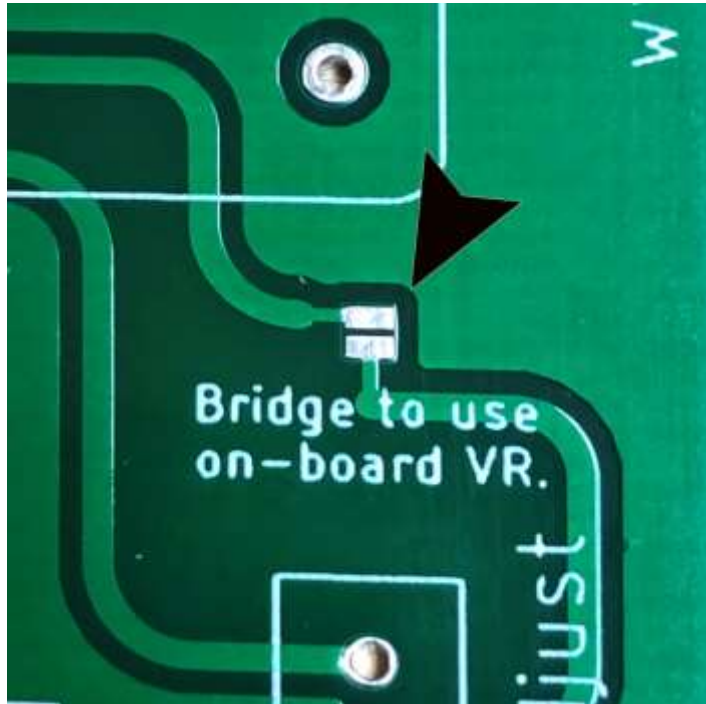

Bridge these two solder pads with solder to bring the control potentiometer into circuit.

The Alternate Sine wave out PCB

This unit operates in an identical manner to the square wave unit but has an additional filter on the oscillator output to create a sine wave output rather than a square wave

For specifications about supply voltage and current needs see the specifications listed in the Appendix B.

For questions, comments etc. please contact us here:

steve@electroresales.com



Appendix A

Schematic – Square wave module

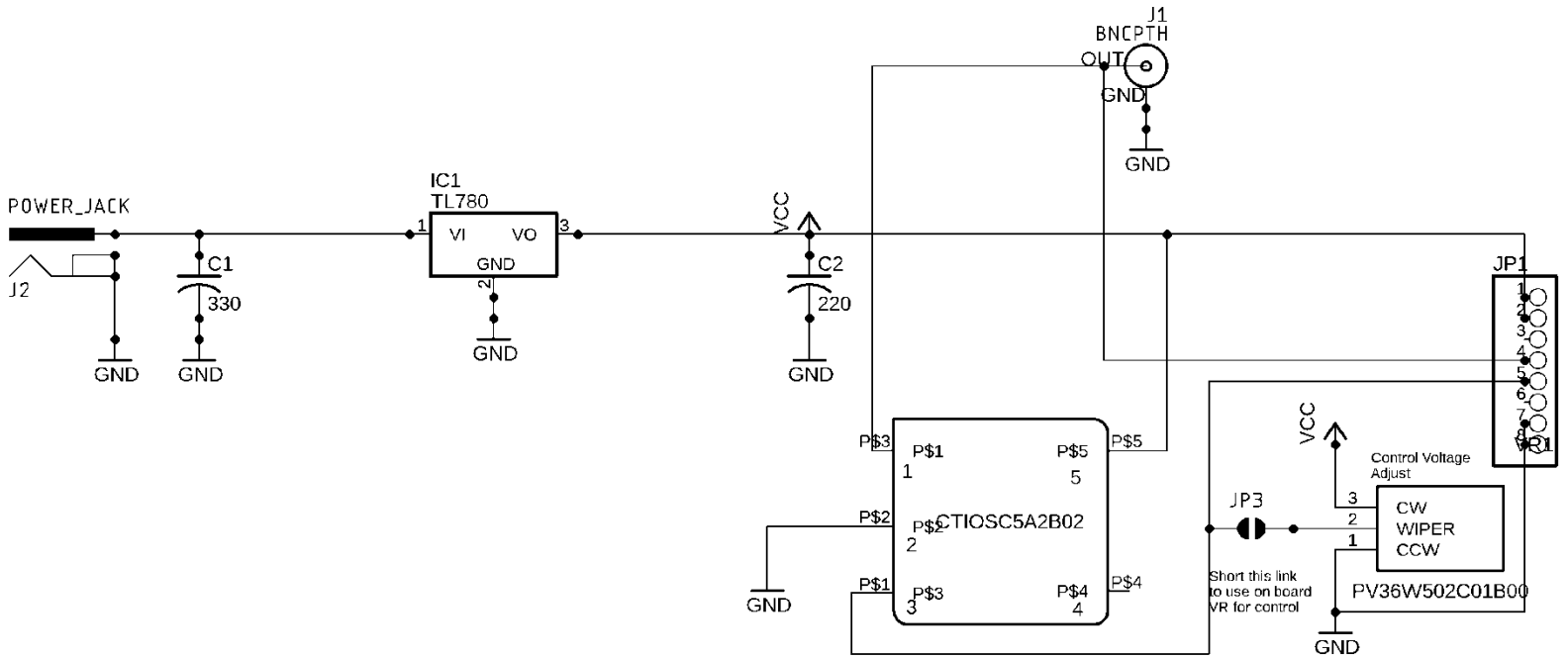

Board Parts Layout

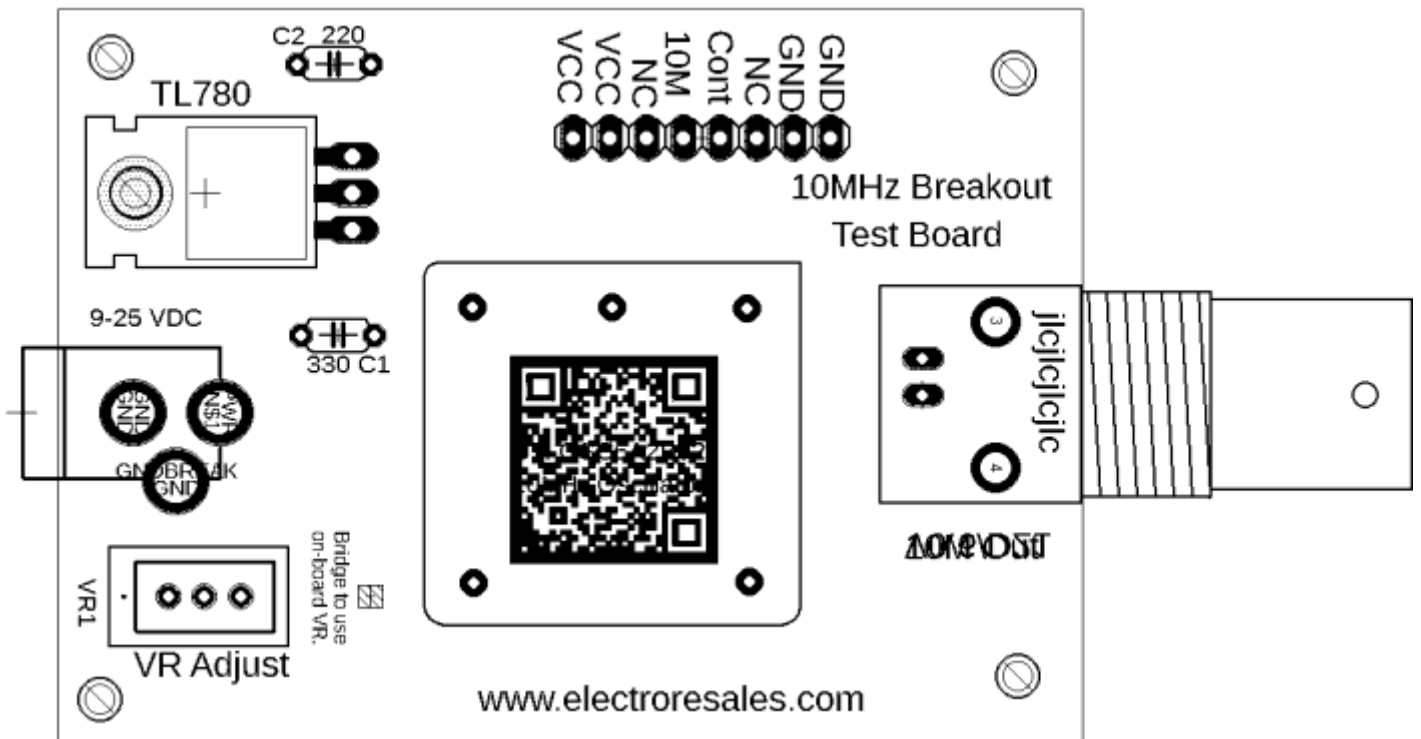



Electro-Resales LLC

Think-Design-Make

11287 S. Lake Crest Dr.

Olathe, KS. 66061

913-544-6184

Appendix B

Specifications

1. Supply voltage – 5VDC
2. Supply current – 450mA (Warm-up), 250mA (Running after warm-up)
3. Output – Sine or square wave
4. Control voltage – Max 4.5VDC at the 'Cont' Pin, vary voltage to alter frequency
5. PCB Dimensions – 3" x 2" Approx.

Parts List

- 1) 78S05 Voltage regulator
- 2) Heatsink
- 3) VR1 – 25 Turn Potentiometer – Mouser P/No; 81-PV36W501C01B00
- 4) BNC
- 5) OCXO - Cti OSC5A2B02
- 6) Header strips
- 7) 2 x bypass capacitor 0.1uF (104)
- 8) 2.1mm Barrel jack

Note the bypass capacitors are marked as 220 and 330 on the PCB itself.



Electro-Resales LLC

Think-Design-Make

11287 S. Lake Crest Dr.
Olathe, KS. 66061
913-544-6184

Appendix C

The sine wave output from the module sold as sine wave out.

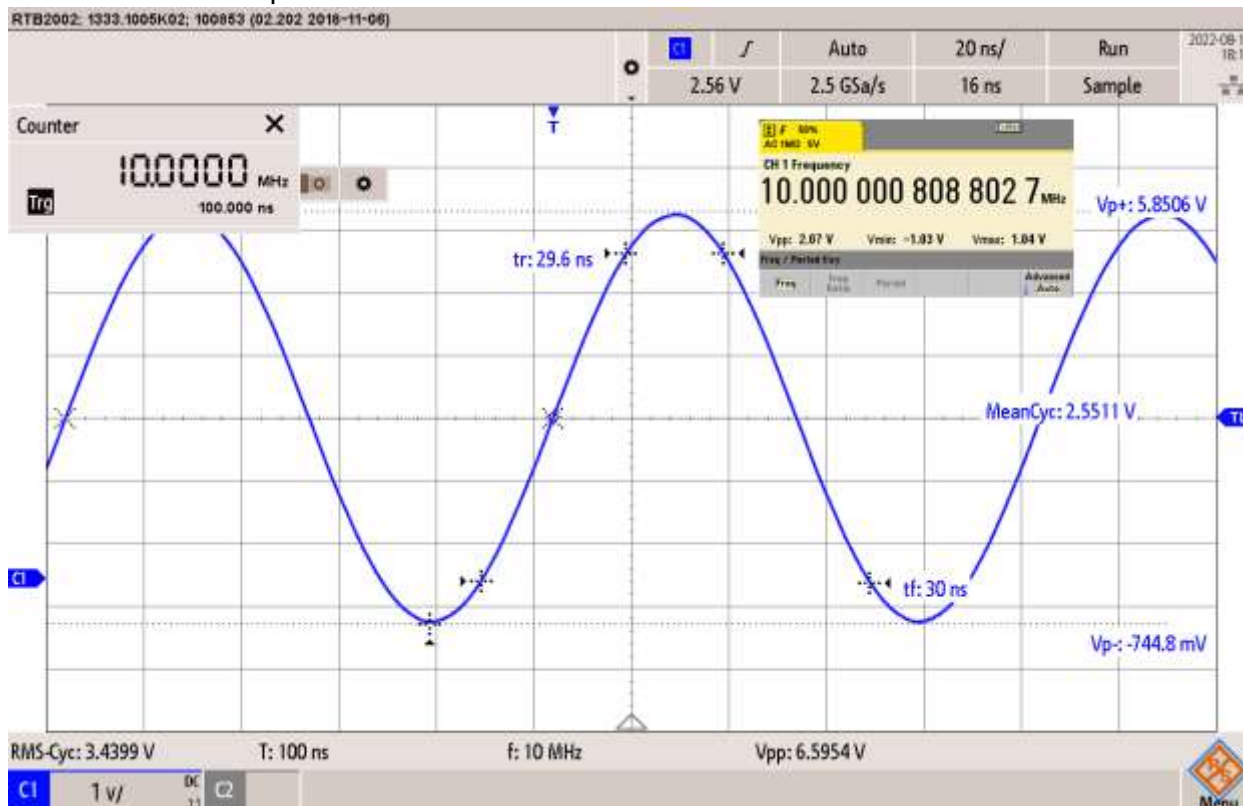

The square wave output from the module sold as square wave out.

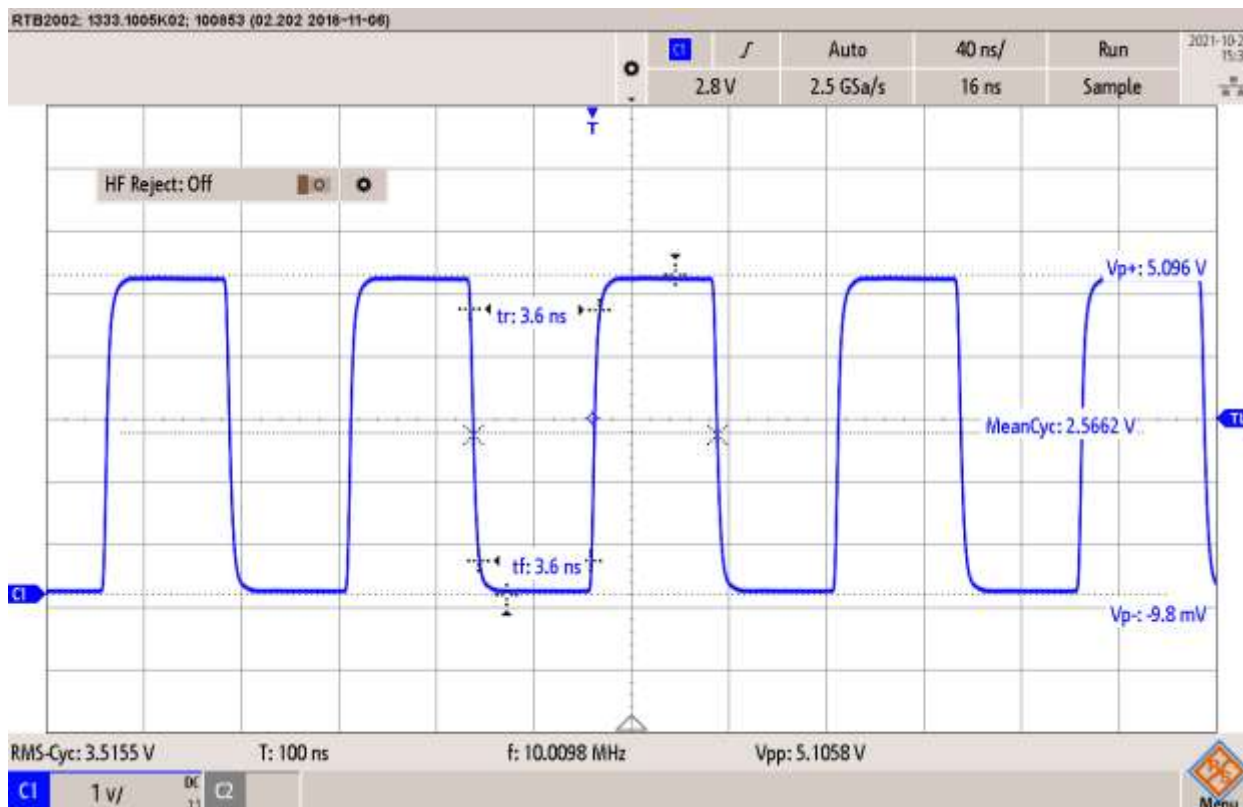



Electro-Resales LLC

Think-Design-Make

11287 S. Lake Crest Dr.

Olathe, KS. 66061

913-544-6184