

CONTINUOUS TELE POCKET CAN BE ADAPTED TO ANY CEILING TYPE WHEN SAMPLE OF CEILING SYSTEM SUPPLIED

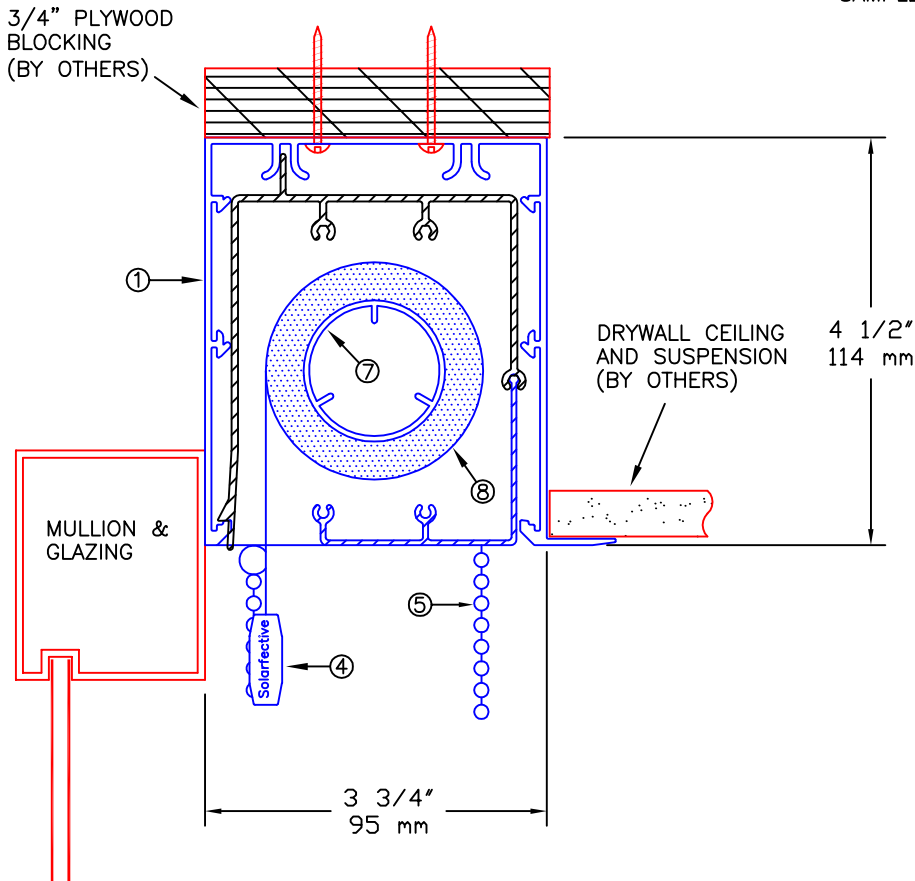

NOTES:

1. CONTINUOUS ALUMINUM TELE POCKET SYSTEM
2. 1" WIDE PUSH-UP CLIP
3. EXTRUDED ALUMINUM HALF FASCIA
4. EXTRUDED ALUMINUM EXTERIOR HEMBAR
5. STAINLESS STEEL BALL CHAIN
6. ABS END BRACKET (3 1/16" X 3 13/16")
7. 1 1/2" Ø EXTRUDED ALUMINUM TUBE
8. FABRIC: 1%, 3%, 5%, 10% OPENNESS OR BLACKOUT

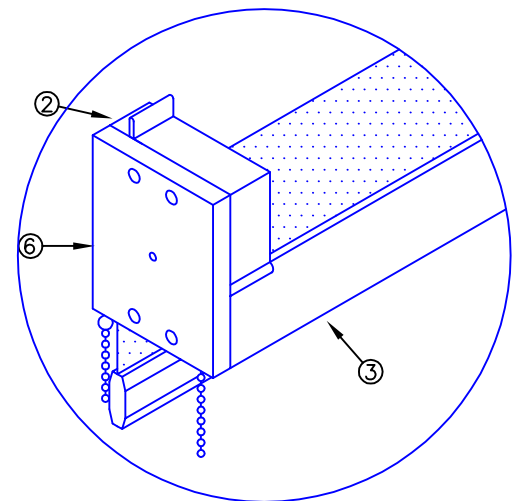

Solarfactive

55 Hymus Road, Scarborough
Ontario, Canada. M1L 2C6

Tel. (416) 421-3800
Fax. (416) 421-8424

Web Site: www.solarfactive.com
Email: shades@solarfactive.com

CONTINUOUS TELEVENT SYSTEM
PUSH-UP MOUNTING DETAIL

PROJECT: -

DATE:
JAN. 01, 2015

SCALE:
N.T.S.

FILE No.
-

DRAWN:
ADIE

DWG. No.
T-17

REV
0