

2025 BC-3.5: CLASSIC & ROCK SERIES

COMMERCIAL COFFEE ROASTERS

BY BCROASTERS.COM

2025 OFFERS TWO STYLE OF BODIES FOR THE BC-3.5!

THE YEAR 2025 OFFERS 2 STYLES ON OUR BC-3.5 & 5 MODELS. WE HAVE THE "CLASSIC LINE" WHICH FEATURES THE 'LOOKS' YOU HAVE COME TO KNOW IN THE BC ROASTERS WITH A COUPLE NEW FEATURES. BUT WE ALSO ARE ADDING THE 'ROCK SERIES' WHICH FEATURES A NEW MUCH MORE HEAVY DUTY BODY TYPE WITH THE OPTION TO ADD YOUR OWN CUSTOM LOGO ON THE FRONT OF ROASTER. MORE DETAILS OF THESE ARE HIGHLIGHTED BELOW.

FEATURES OF THE 2025 BC-3.5

ALL THE FEATURES OF THE PREVIOUS YEARS ARE ON THE 2025 MODELS: THE 'CLASSIC' MODEL IS OFFERED IN BOTH SINGLE OR DOUBLE WALL MODELS. AND THEY CAN ROAST BATCHES AS SMALL AS 1/2LB. UP TO 3.5 POUNDS! (SW-16OZ TO 3.5LB.) THE GAS MODELS CAN ROAST UP TO 5 ROASTS PER HOUR .ELECTRIC MODELS CAN ROAST 3LB. PER ROAST AND UP TO 3.5-4 ROASTS PER HOUR. MOST FEATURES ARE OFFERED AS STANDARD ON THE BC-3.5 SUCH AS COMPLETE CONTROL OF AIRFLOW WITH THE MDDS SYSTEM. THE MAG AIRFLOW GAUGE ALLOWS YOU TO MONITOR AIRFLOW THROUGH THE DRUM. A NEEDLE VALVE GAS VALVE ALLOWS PRECISE CONTROL OF GAS PRESSURE AND DRUM SPEED CONTROL ALLOWS FOR FINE TUNING OF ALL TYPES OF BEANS. THESE COME WITH SOLID HEAVY-DUTY STAINLESS STEEL DRUMS IN SINGLE OR DOUBLE WALL (DOUBLE WALL ONLY ON THE ROCK SERIES MODELS) AND BUILT IN PROFILING SYSTEM FOR BT & ET. DIRECT-CONNECT CHAFF UNIT FOR EFFICIENCY & REDUCED FOOTPRINT. THE 2025 MODELS ADD A NEW TYPE NECK ON ROASTER AND HOPPER GATEWAY.

BC-1 THRU 8 GAS MODELS COME WITH A FREE 110-120 VOLTAGE CONVERTER



'CLASSIC LINE'
OUR BC-3.5 & 5 OFFER THE ORIGINAL CLASSIC LOOK WITH THE NEW 2025 NECK & HOPPER GATEWAY

'ROCK SERIES'
OUR MOST HEAVY DUTY BODY EVER BUILT ON A BC MODEL TO DATE.

GET YOURS WITH YOUR LOGO, OR NO LOGO OR OUR LOGO: YOUR CHOICE



SPEC SHEET

BC-3.5MD	GAS TYPE	ELEC. TYPE
Batch Size	8oz-3.5lb	8oz-3lb.
Roasting Time	9-14 minutes	15min.
Production	14-18b.hr	9-12
Heat Source	NG/LPG	Electric
Voltage	220V*	220V
Wattage	225W	4250W
Drum Motor	60W	40W
Chaff Fan Motor (HD)	60W	60W
Cooling Fan Motor	60W	60W
MIXING ARM	15W	15W
BTU	30-35,000	
NG PRESSURE	Recommended 7WC	
LPG PRESSURE	MAX.18WC	
Gas Consumption	0.3KG/hr .	
Roaster Dim.	38x28x35 Inches	
Roaster Weight	140KG 307lb.	
Crate Dim	48x33x43 (LxWxH)	
Crate weight	168Kg 370lb.	



THE BC-3.5 IS A HEAVY DUTY ROASTER BUILT WITH A CARBON STEEL BODY WITH APPROVED POWDER COAT HIGH TEMPERATURE BODY IN BLACK, WHITE OR RED & PURPLE. THE HOUSINGS ON THE 'CLASSIC LINE' COME IN SOLID COLOR CHOICES & TEXTURED COLORS.

TWO EXHAUST PIPES COMES OFF THE BC-3. **THE EXHAUST OFF THE NEW HD CHAFF FANS IS 4" WIDE & THE COOLING TRAY IS 3".** THEY CAN BE EXHAUSTED OUT OF BUILDING SEPARATELY OR CONNECTED WITH A BLAST OR BACKDRAFT DAMPER

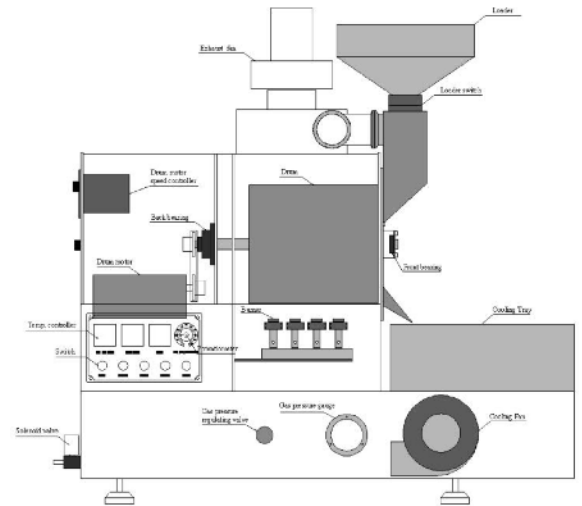

DETAILED DRAWINGS TO SHOW MEASUREMENTS OF THE BC-3.5

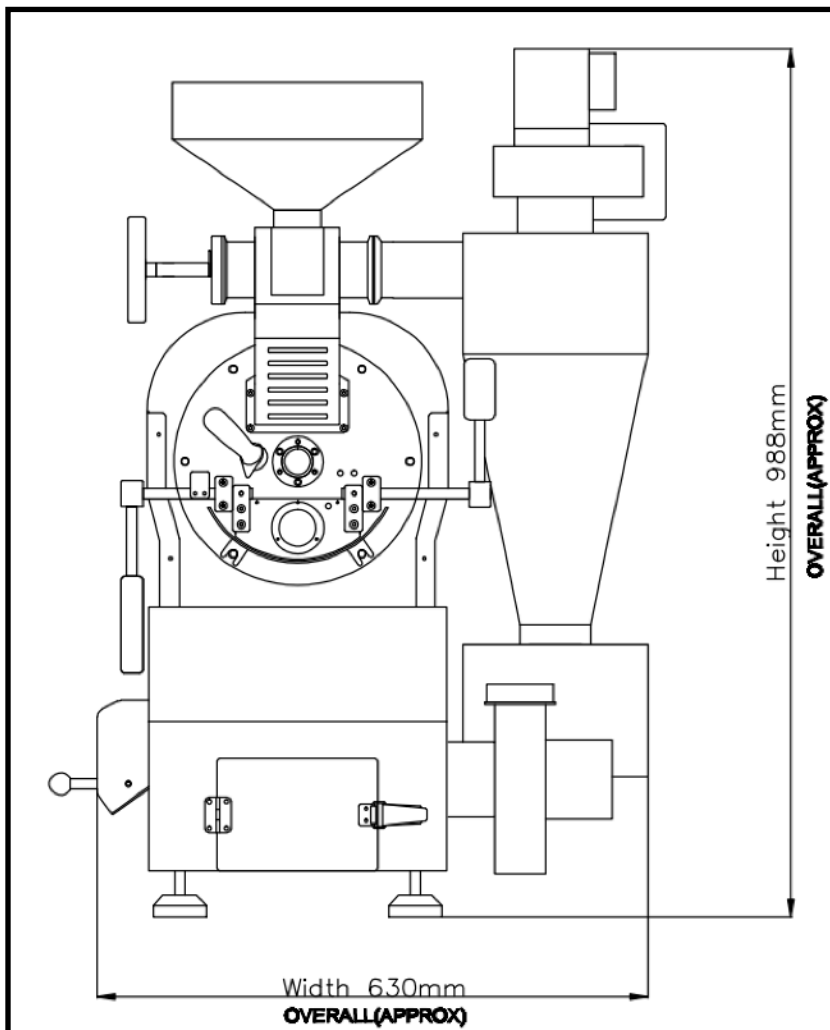

'ROCK SERIES MODEL'

THE DESIGN FROM FRONT HIGHLIGHTS THE NEW NECK DESIGN AS WELL AS HOPPER GATEWAY.

ALSO NOTE THE NEW HEAVY DUTY CARBON STEEL WRAP AROUND THE DRUM MAKING THE ROCK SERIES OUR MOST HEAVY DUTY BC-3.5 TO DATE

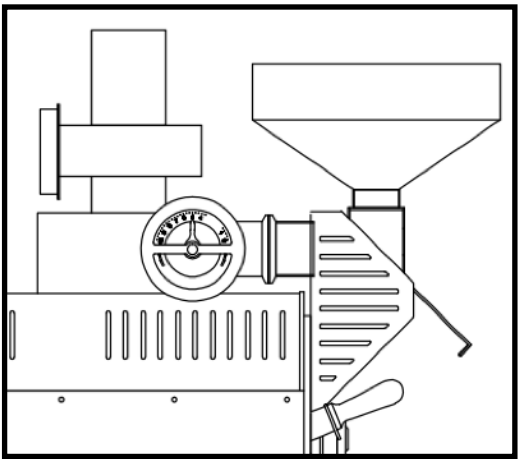

TOP VIEW:

12"-18" CLEARANCE ON ALL SIDES OF ROASTER ARE NEEDED

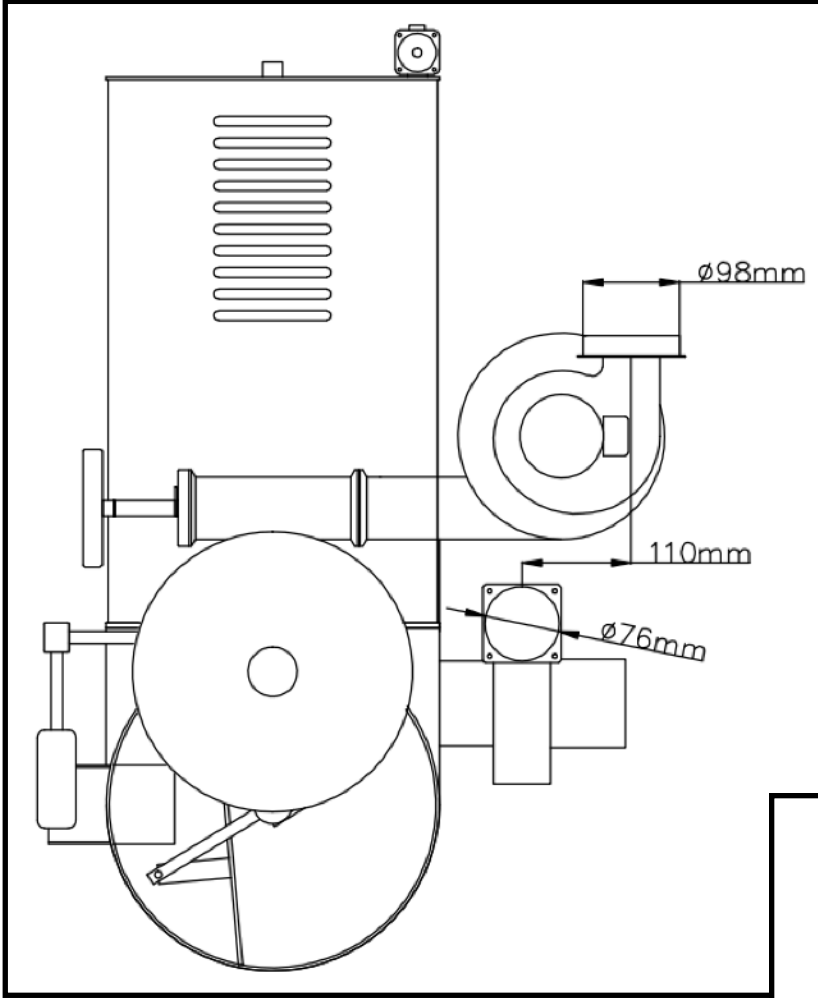

BC-3.5 SIZE:
950x700x970mm
38x28x35in.
(LxWxH)

CLEARANCE FROM ALL COMBUSTABLE SURFACES
12-24" SPACE ON ALL SIDES

'CLASSIC LINE'

FEATURES ALL THE SAME LOOKS AS OUR PREVIOUS YEARS EXCEPT FOR THE NEW NECK & HOPPER FEATURES WHICH MATCH THE ROCK SERIES DESIGN.

NOTE: THE BC-3.5 CLASSIC HAS SOME SLIGHTLY DIFFERENT MEASUREMENTS

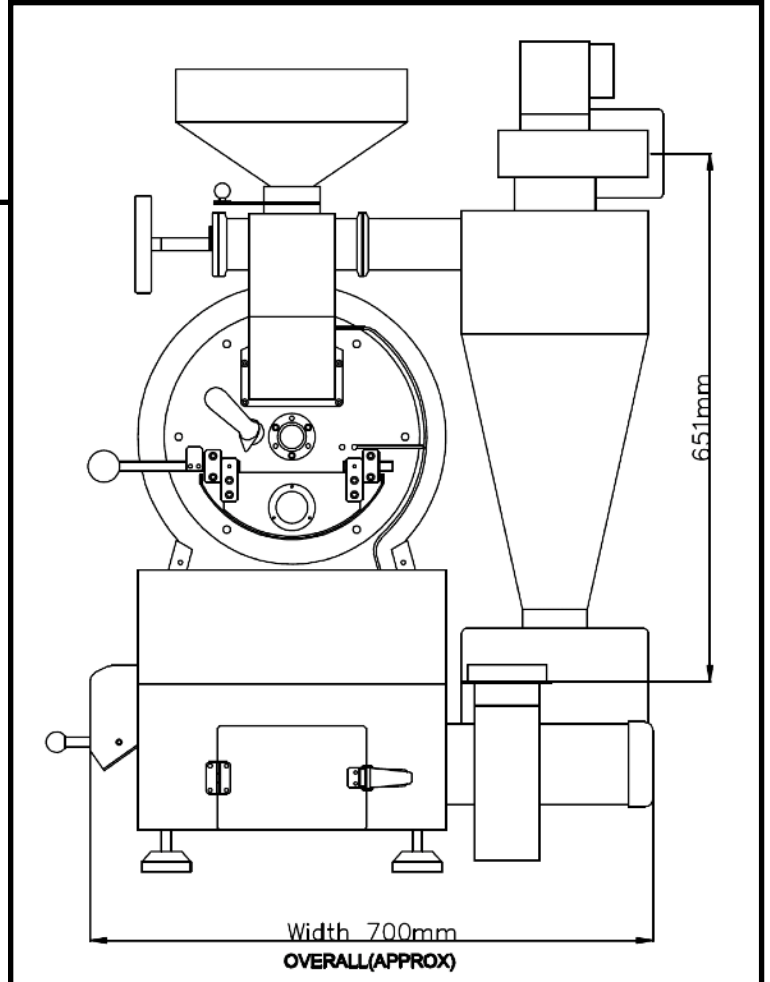
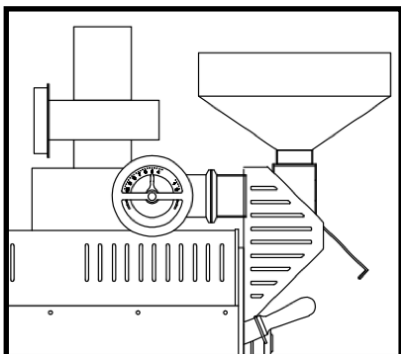

BODY COLOR CHOICES:
BLACK, RED, WHITE or PURPLE BODIES

CLASSIC HOUSING COLORS

12 Housing Color Choices on the CLASSIC LINE ONLY

SOLID COLORS



ROSE GOLD STAINLESS BLACK TITANIUM

CHECKERED TEXTURES

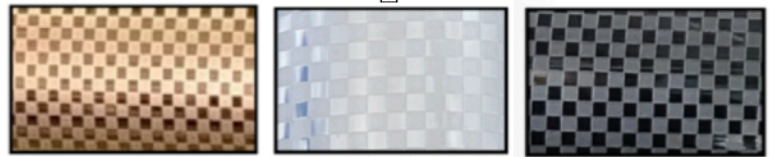

CHECKERED ROSE GOLD CHECKERED SILVER CHECKERED BLACK

RAINDROP TEXTURES

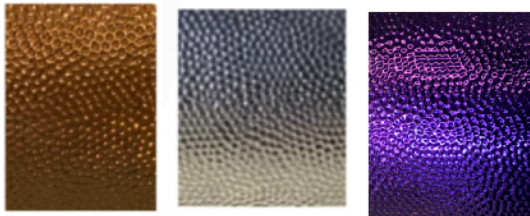

ROSE GOLD SILVER PURPLE

HAMMERED TEXTURES

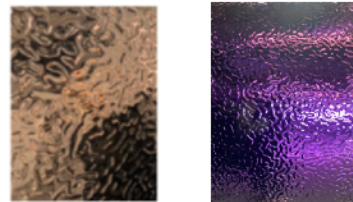

ROSE GOLD PURPLE

LIMITED TIME SPECIAL



SOLID PURPLE

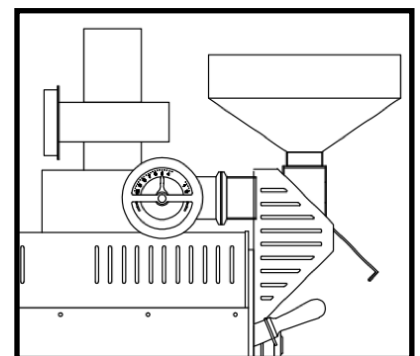
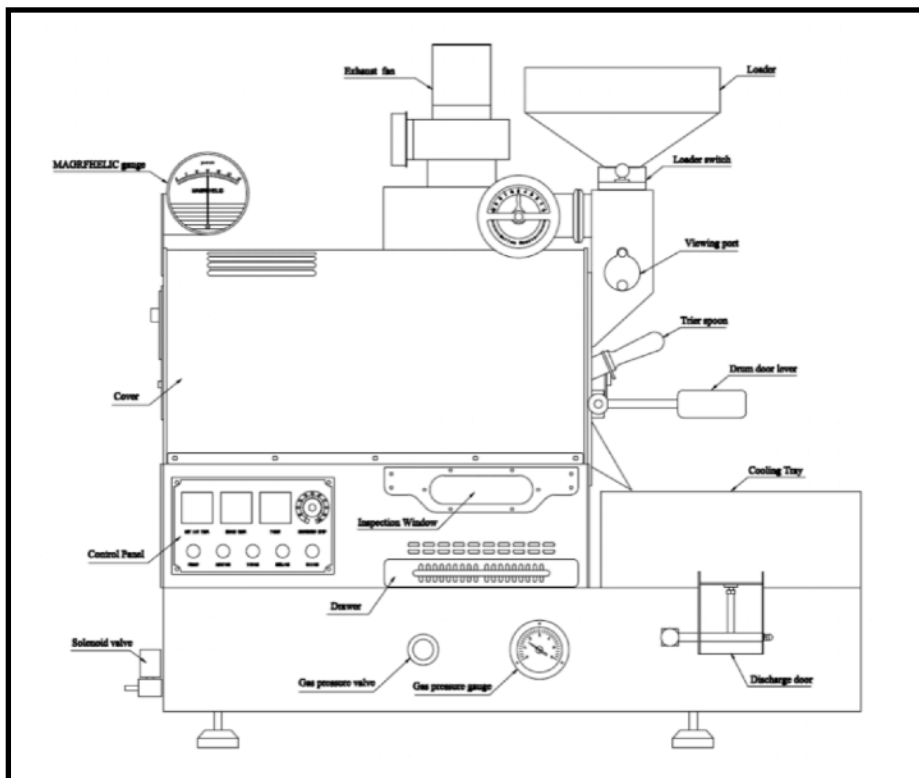

'CLASSIC LINE'

THE 2025 CLASSIC BC-3.5 & 5 OFFER A NEW TYPE ROASTER TECH AND HOPPER GATEWAY WHICH REPLACES THE STYLE IN EARLIER YEAR MODELS AS SEEN ABOVE.

BC-3.5 COMMERCIAL COFFEE ROASTER

*TABLETOP OR STAND MODEL (18-24" STAND SUGGESTED)
*DIRECT CONNECT CHAFF UNIT FOR SMALLER FOOTPRINT
*CHOICE OF ALL ELECTRIC OR GAS MODELS

SIZE SETUP (LxWxH)	38x25x37" (LxWxH) INCLUDES DIRECT CONNECT CHAFF UNIT IN MEASUREMENT
WEIGHT	307LB
MINIMUM CLEARANCE FROM COMBUSTABLE MATERIALS	18-24"
ROASTING CAPACITY	1LB TO 3.5LB SINGLE WALL 8OZ TO 3.5LB DOUBLE WALL
ROAST TIME & ROASTS PER HOUR	9-14 MINUTES (5 ROASTS PER HOUR GAS. 3.5 PER HOUR ELECTRIC)
DRUM INFORMATION	SW DRUM: 4MM SUPERIOR 304SS CONTAINS 18% CHROMIUM AND 8% NICKEL DW DRUM: HAS TWO LAYERS OF 2MM 304SS WITH 4MM OF AIR CUSHION. SS WELDING
ELECTRIC STATS:	GAS MODEL: SINGLE PHASE 220V 50/60HZ 225W REQUIRES STANDARD 15A BREAKER ALL ELECTRIC MODELS: SINGLE PHASE 220V 50/60HZ 5225W REQUIRES 30A DEDICATED BREAKER
ELECTRICAL PLUG TYPE	GAS MODELS: 20A 250V 3 WIRE NEMA 6-20P ELECTRIC TYPE: LOCKING PLUG 250V 30A NEMA L6-30P
FUEL CHOICES ON GAS MODELS	LPG GAS STANDARD WITH MODELS. NATURAL GAS CONVERSION KITS OFFERED FOR CUSTOMER INSTALLATION ONLY.
BURNER INFORMATION ON GAS MODELS	SW BURNERS: 6 STANDARD HD BURNERS DW BURNERS: 8 STANDARD HD BURNERS
BTU REQUIRMENTS	30,000 BTU MINIMUM REQUIRED FOR NG LINE
GAS PRESSURE	LPG: 12-16WC (3-4KPA) MARSHALL 1912/197 REGULATOR RECOMMENDED NG: 7-14WC
EXHAUST PIPE SIZE	100MM (4") OFF CHAFF UNIT. 76MM (3" OFF COOLING TRAY)



OPTIONAL COOLING TRAY COVERS

COOLING TRAY COVERS PROTECT HANDS AND KEEP PRODUCT SANITARY ESPECIALLY WHEN ROASTERS ARE LOCATED IN COFFEE SHOPS AND WAREHOUSES.

EXHAUST SETUP	
EXHAUST PIPE REQUIREMENTS	POSITIVE PRESSURE EXHAUST VENTING WITH MINIMUM CLEARANCE 18-24" FROM COMBUSTABLE MATERIALS
MAXIMUM VENTING LENGTHS	20-25' FROM CHAFF UNIT. DEDUCT 3-5' FOR 45-90 DEGREE PIPE ELBOWS. IF YOU MUST VENT AT LONGER LENGTHS CONSULT A LOCAL TECHNICIAN ON USE OF POSSIBLE BOOSTER FANS
MAXIMUM EXHAUST TEMPERATURES	425-475F
CHAFF UNIT HIGH TEMP.	300-350F
COOLING TRAY HIGH TEMP.	200F
DATA LOGGING VIA ARTISAN OR CROPSTER	BUILT IN DATA LOGGER ATTACHES TO COMPUTER (PC OR MAC) VIA USB OR BLUETOOTH
K TYPE THERMOCOUPLES	BT & ET WITH TWO ADDITIONAL PREDRILLED CAPPED THREADED HOLES TO ADD OR ADJUST LOCATION OF PROBES
MANUFACTURED IN CHINA FOR BC ROASTERS	CUSTOM BUILT FOR BC SPECS IN USA AND OVER 200 LANDS

IMPORTANT NOTE ON EXHAUST SETUP OF THE NEW HD LINE OF ROASTERS:

THE NEW 2022 HD LINE OF ROASTERS INTRODUCED IN 2021 FEATURE A NEW HEAVY DUTY CHAFF FAN. THIS FAN HAS AN EXHAUST PIPE OF 100MM. THEREFORE IT REQUIRES A 4" PIPE TO ATTACH TO THE CHAFF EXHAUST (OTHER MODELS THAT ARE NOT THE NEW HD LINE USE A 3" PIPE)

YOU MAY CHOOSE TO GET A 4 PIPE TO RUN AS MAIN TRAY EXHAUST OFF CHAFF UNIT. 3" EXHAUST OFF COOLING TRAY

COMPUTER DATA LOGGING VIA ARTISAN SOFTWARE

RECORD ROASTS VIA USB OR BLUETOOTH TO DUPLICATE PROFILES USING ARTISAN SOFTWARE.



BUCKEYE COFFEE IS A PROUD MONTHLY SPONSOR OF ARTISAN SOFTWARE

ARTISAN SOFTWARE

Do your part to Keep Artisan Alive and Well.

Donate to Artisan Here:

<https://artisan-scope.org/donate/>

DO YOUR PART!

CONSIDER ARTISAN PLUS

<https://shop.artisan.plus>



artisan+

BCROASTERS.COM BC ROASTERS WAREHOUSE: AVONDALE, AZ 85323 info@BuckeyeCoffee.com

ALL BC MODELS CAN BE SETUP TO USE WITH PROFILING SOFTWARE ON A PC OR MAC COMPUTER

**OPTIONAL CUSTOM MADE LOGO OF YOUR BUSINESS NAME CAN BE
PUT ON THE 'ROCK SERIES' ROASTERS:
EMAIL US FOR DETAILS**



**WE CAN PUT OUR COMPANY
LOGO OR YOUR COMPANY LOGO
OR NO LOGO IF YOU PREFER ON
THE 'ROCK SERIES' MODELS
YOUR CHOICE!**



'ROCK SERIES'
WITH OPTIONAL
RAINDROP HOUSING
CHOICE OF GOLD, SILVER
OR PURPLE RAINDROP
1/2 HOUSING TO LIVEN
UP THE COLORS IN YOUR
COFFEE SHOP!

WWW.BCROASTERS.COM

**BC ROASTERS
BUCKEYE, ARIZONA 85326
TONOPAH, ARIZONA 85354**

**TOLL FREE: 844.522.6333
INFO@BCROASTERS.COM**