

The Octal Tri-Bander SSB Transceiver

Mike Bohn, KG7TR

April, 2026

Introduction

The Octal Tri-Bander Transceiver shown in Figure 1 is a follow-on to my Octalmania radios built several years earlier. Like Octalmania, this homebrew transceiver uses only octal tubes, 19 of them. It covers the 80, 40 and 20 meter bands, operates on single sideband only, and delivers 100 watts PEP output. This is a single conversion radio based on a 9 MHz intermediate frequency. A modern INRAD crystal filter provides 2.1 KHz bandwidth for both receive and transmit. Vintage ARC-5 Command transmitter components were used to build a stable VFO covering the 5.0 to 5.5 MHz range. Although all of the tubes used were in production by 1952 or earlier, the performance of this radio is on a par with any of the tube type SSB radios built into the 1970s.

The majority of this transceiver uses proven designs from the Octalmania radios, with common circuitry such as the SSB filter, first IF amplifier, VFO and BFO sharing both receive (Rx) and transmit (Tx) functions. 80 and 20 meters are covered by mixing the 5 MHz VFO with the 9 MHz IF. Since 40 meter coverage was not part of the Octalmania design, a new pre-mixer/buffer circuit was developed for this project to provide 16.0 to 16.5 MHz injection frequencies for transceiving in the 40 meter band. All power for the transceiver comes from a matching Power Supply/Speaker Unit (PSSU) shown in Figure 2. A digital frequency readout is used to provide accuracy of better than 100 Hz. This allows more practical operation in the modern environment, and avoids the complications of trying to homebrew a linear VFO and mechanical readout that could never achieve this kind of accuracy.

The cabinets for the transceiver and PSSU are custom homebrew designs. They use aluminum angle stock, aluminum perforated sheet, and lots of stainless steel machine screws that fit into drilled and tapped holes. The styling and size also match my 813 linear amplifier that was homebrewed around the same time. The linear is described in separate documents available at kg7tr.com. The front panels of all units were painted light gray, labeled with custom designed water slide decals and then sprayed with a matte finish.

There is more information on general homebrewing techniques used to build this radio on the button at the bottom of my home page at kg7tr.com. This includes cabinet construction, panel and chassis decals, and custom meter scales.

From start to finish, it took twelve months of almost full time effort to complete the transceiver, PSSU and linear, including all documentation. The result is an integrated, homebrew radio station that looks great inside and out, and works as great as it looks.

Mechanical Layout

This is a big radio that uses conventional rack panel and chassis construction popular with homebrewers of the vacuum tube era. The transceiver is built on a 13 x 17 x 4 inch chassis mated to a 10.5 x 19 inch rack panel. In the cabinet the radio measures 19W x 11H x 13D. The PSSU is built on a 10 x 12 x 3 inch chassis. It required fabrication of a custom 12 x 10.5 inch front panel. With cabinet this unit becomes pretty much a 12 inch cube.

The transceiver top and bottom views are shown in Figures 3 and 4 respectively. Much thought went into laying out the radio. A major challenge was locating the Rx/Tx common circuitry so that wire lengths could be kept as short as possible. Another goal that was successfully achieved was placement of receiver controls on the left side of the front panel, transmitter controls on the right side, with the bandswitch smack in the middle.

Topside, the power amplifier tubes and pi-net components are enclosed in a ventilated 6 x 6 x 6 inch cage at the right rear of the chassis. The interior of the PA cage is shown in Figure 5. The design of the PA was copied from an Eldico T-102 transmitter I have. Use of a rotary inductor avoids the mechanical and electrical complications of having to bandswitch the PA coil. Note the turns counter that drives the rotary PA inductor. This assembly was designed for a 15 turn precision potentiometer, but it works fine with the 17 turn rotary inductor as only 11 turns of the inductor range are actually used to cover 80, 40 and 20 meters.

The four inch chassis height allows the ARC-5 VFO components to be flipped over from their positions in the original donor equipment, as evidenced by the VFO capacitor visible topside in the lower left portion of Figure 3. This gets the main frequency tuning knob up higher in a more useable position. Stainless steel 1/4 inch shafts riding in panel bearings and mated with flexible couplings are used to reach the PA rotary inductor and the four variable capacitors that are adjustable with front panel knobs. The seven coil cans visible topside contain 9 MHz toroid coils. Six of these also contain trimmer capacitors. The cans were scavenged from an RF unit from an airborne transceiver. All ceramic trimmers used throughout the radio came from the same source.

Underneath the chassis can be seen several shields separating the various circuits into compartments. These were fabricated using .5 inch aluminum angle stock that is .063 thick, .063 tempered aluminum sheet, and either pop rivets or machine screws and nuts to fasten them all together. The bandswitched circuits run along the chassis centerline from front to back, and are compartmentalized to separate active circuits from one another. From front to back, these are the Rx RF amplifier, Rx mixer, Rx/Tx premixer/buffer, Tx mixer and Tx driver. A total of seven ceramic switch wafers are used, each with one to three poles of contacts. The wafers were mounted to shields that can be removed for access to the bandswitched components or the circuitry underneath. A typical removable section is shown in Figure 6. Here you can see the typical mounting used for the toroid coils used in the bandswitched sections, as well as the IF cans. Mounting posts made from 3/16 inch fiberglass rods are increased in diameter with some masking tape to allow a tight fit of the wound toroid. These posts are then pushed into a rubber grommet and secured with cyanoacrylate adhesive (aka "Super Glue"). Epoxy is used to secure the toroid itself to the post.

As can be seen in the upper left of Figure 4, the PA loading capacitor was mounted below chassis in its own compartment in order to simplify the overall layout. To the right is a compartment for the PA tubes. In the lower left of the chassis is another compartment containing the transmitter audio amplifier, tone oscillator, balanced modulator, BFO and 21.5 MHz oscillator circuits. In the lower right compartment of the chassis are the ARC-5 VFO components. Inside the oblong can are the coil and range set capacitor from the original WWII radio, mounted underneath the chassis for this application as mentioned before. Behind the VFO are several compartments separating the IF amplifiers, AGC amplifier, product detector and Rx audio amplifiers.

The rear of the transceiver is shown in Figure 7. All controls and jacks are labeled with decals. Separate controls are used to zero the meter in AGC (Rx) and ALC (Tx) modes. Power

comes in on an 11 pin connector. Pin connections are identified on a decal next to the connector. The rear bearing of the bandswitch shaft can be seen in the center of the chassis. This view also shows typical construction of the cabinet frames.

The top and bottom of the PSSU are shown in Figures 8 and 9. The four large electrolytics, rectifier diodes and terminal standoffs are mounted on a piece of blank fiberglass board cut and drilled to fit the components. The components are interconnected on the opposite side using point to point wiring, and the whole assembly is mounted to the chassis on threaded aluminum spacers. The only other item of interest here is the 3/4 x 1/8 inch angle stock running sideways across the chassis. This angle picks up mounting bolts from the two transformers at the rear to strengthen things.

I have found that larger aluminum chassis typically available today are made from relatively thin, soft aluminum (I suppose they always were). They do not support heavy components very well, particularly as you move away from the chassis edges. Additional bracing is required to keep stuff from flexing during handling, which can lead to broken wires and components. The transceiver chassis ended up being pretty stiff as a result of all the shields firmly mounted underneath the chassis. The cabinet frames and their panels provide a lot of additional sheer strength. When they are in place the radios are solid as bricks.

Another feature I have incorporated into my radios is a 1/8 inch thick aluminum strip that is fastened along the bottom chassis edges with countersunk machine screws. They are visible in the photos. The bottom covers are then fastened to these strips using machine screws threaded into drilled and tapped holes. With this technique the more common method of using sheet metal screws is avoided. I am not a fan of sheet metal screws, especially when they are used with thin, soft aluminum on assemblies that require frequent removal and installation. We all know how that ends up. There are also self-clinching nuts available that can be used. The trade name is PEM®. SAE sizes from PEM (a U.S. manufacturer) are pretty expensive. While there are Chinese made clones, there are typically only available in metric sizes.

Cabinet Construction

The cabinets are constructed on frames built primarily from one inch angle stock that is 1/8 inch thick. This thickness allowed holes to be drilled and countersunk to fasten the corners together with smaller joiner pieces. The joiner pieces were cut from 3/4 angle and flat bar stock, also 1/8 inch thick. They were drilled and tapped with 8-32 threads. The frames were then assembled using Phillips flat head machine screws. All pieces were aligned and clamped together before drilling. Subsequent countersinking and use of countersunk screws locates all pieces precisely without the need for any adjustments, and allows the panels to be mounted flush to the angle stock.

With the frames completed, top, bottom and side panels were cut to size from .063 inch thick perforated aluminum sheet and temporarily taped into place after squaring up all three axes. Then pilot holes were drilled through existing holes in the sheets. These holes were then tapped with 6-32 threads and the panels fastened with pan head Phillips screws.

The sides of the front rack panels were fastened to the frames using 1/4-20 pan head Phillips screws. The front frame pieces were drilled and tapped to accommodate these screws. Across the top 8-32 countersunk screws fasten the top frame piece to the front panel, again with the screws providing precision location.

Small angle stock brackets are fastened to the rear sides of the chassis. These were drilled and tapped to receive a 1/4-20 screw through the rear of each side of the cabinet frame.

At the end of the day, if it weren't for the oddball size of the PSSU, I would have been better off in terms of time and money buying commercial rack cabinets. But then they would have been larger and heavier than my designs, and the radios would have been somewhat less than 100 percent homebrew...

Block Diagram Circuit Description

A block diagram of the transceiver is shown in Figure 9. This radio uses independent tuned circuits for the receiver front end and the transmitter driver and PA, instead of sharing them as was typical in a lot of the old commercial transceivers. Although it takes a few additional parts and requires an extra tuning control, I figured in the end it would be less trouble to do it this way. Starting at the lower left of the diagram, the antenna jack is connected to a T/R relay. In the Rx mode the antenna is routed to bandswitched LC circuits that feed RF amplifier V1. The output of V1 is run through another set of LC circuits and then on to mixer V2. The LC circuits are tuned by a dual section variable capacitor brought out to the front panel as the RECEIVER PRESELECTOR control. AGC is applied to V1.

V2 is a pentagrid mixer that combines the amplified RF from V1 with a mixer injection voltage from bandpass circuits in the output of V10. The injection frequency is 5.0 to 5.5 MHz for 80 and 20 meters, and 16.0 to 16.5 MHz for 40 meters. The output of V2 is a 9.0 MHz IF signal that is applied to the crystal filter through a matching transformer and a T/R relay. This is a very small DPDT relay with gold alloy contacts that is designed for "dry" or low level signal switching. This same type of relay is used several places. In this circuit one set of contacts in the relay switch the signal going into the filter between the receiver mixer and the transmitter balanced modulator. The other set of contacts short the unused signal to ground (i.e., in Rx mode the balanced modulator output is shorted to ground, in Tx mode the RX mixer output is shorted to ground).

The output of the crystal filter is applied to the grid of V3 through another matching transformer. V3 functions as an IF amplifier for both Rx and Tx modes. Another T/R relay contact set switches gain control of V3 between AGC for Rx and ALC for Tx. This is a common technique used in transceivers like this (e.g., KWM-2, SB-100, etc.). In Rx mode the output of V3 is fed to V4 and V5. V4 is an IF amplifier whose output goes to V6, the product detector. V5 is a high gain AGC amplifier whose output is rectified to generate the Rx AGC voltage. This voltage is fed to V1, V3 and V4, and holds the audio output level virtually constant once a threshold of a few microvolts of RF at the antenna is exceeded. Negative bias from the IF GAIN control is added to the AGC voltage to control overall gain.

V6 serves as a product detector, with the 9 MHz IF signal applied to the grid and 9 MHz BFO fed to its cathode. Audio is recovered and filtered at the plate, and then coupled to the AF gain control. From here it goes to V7's grid where it is amplified and fed to V8, the audio output amplifier. Output of this stage is transformer coupled to a speaker or headphones.

For the Tx mode, audio from the microphone is amplified by both triode sections of V13, and then applied to the mic gain control through small signal relay contacts when the FUNCTION switch is in the in the PTT or MOX position. When this switch is in the TUNE or LOCK KEY positions, V14 tone oscillator is turned on and its output is applied to the MIC GAIN control through the relay contacts. The signal at the wiper of the MIC GAIN control is fed to the grid of

cathode follower V11A, which in turn provides a low impedance audio source to drive the balanced modulator.

V12 generates the BFO/Carrier signals. The NORMAL SIDEBAND switch on the front panel selects the correct crystal for 80 and 40 meter LSB, and 20 meter USB. Because of the mixing schemes, LSB on 40 meters actually uses the USB crystal. Output from this stage is coupled through a matching transformer to the Rx product detector and the Tx balanced modulator.

The balanced modulator is a ring diode type using four 1N914 diodes. Its double sideband output, absent the carrier, is transformer coupled to the input of the crystal filter in the Tx mode via T/R relay contacts. The filter removes the unwanted sideband from the balanced modulator DSB signal.

In the Tx mode the 9 MHz SSB output of V3 is picked off from a link on the IF coil and coupled to one of the grids of V15. The other grid of this tube is fed the mixer injection voltage from the bandpass circuits in the output of V10. The cathodes of V15 are connected together as are the plates. Mixing action in this stage produces the desired SSB signal. An 80, 40 or 20 meter LC circuit is selected by the bandswitch to filter the output of V15. The resulting signal is fed to the grid V16, where it is amplified to a level suitable for driving the PA grids. The output of V16 is also filtered by LC circuits selected by the bandswitch and coupled into the grids of V17 and V18. The LC circuits at the input and output of V16 are tuned by a dual section variable capacitor brought out to the front panel as the TRANSMITTER DRIVER control.

PA tubes V17 and V18 are connected in parallel and amplify the SSB signal from the driver to 100 watts PEP. Their output is coupled through a pi network to the antenna through contacts on the T/R relay. In addition to variable input and output capacitors, the pi network uses a variable inductor.

If the PA tubes are over driven such that grid current flows, this audio frequency signal is sensed by an audio transformer, and then rectified and filtered to produce a negative ALC voltage that is applied to V3 in the Tx mode through T/R relay contacts. The negative voltage reduces the gain of V3 to help prevent over drive conditions.

V9 serves as a stable Colpitts oscillator whose output varies from 5.0 to 5.5 MHz. Output from the cathode of V9 is coupled to the grid of V10. On 80 and 20 meters V10 operates as a straight through buffer. The output of V10 on these two bands is applied to a 5.0 to 5.5 MHz LC bandpass filter selected by the bandswitch, and then coupled to Rx mixer V2 and Tx mixer V15.

On 40 meters, heterodyne oscillator V11B is turned on. The output of this oscillator is at 21.5 MHz. This signal is applied to the grid of V10 in addition to the VFO signal already present. On 40 meters V10 becomes a mixer with an output of 16.0 to 16.5 MHz. This signal is filtered by a LC bandpass filter selected by the bandswitch and sent to the grids of V2 and V15.

A small pickup wire is mounted next to the main VFO coil. This signal is sent to the digital frequency counter/readout, where a programmed IF offset is selected by the bandswitch to produce the correct output frequency display. Since this counter only allows one offset per band, the value for the "normal" sideband is programmed. If the reverse sideband is selected (e.g., USB on 80 meters) a readout error will result.

V19 provides regulated +150 volts to the three oscillators - V9, V11B and V12. Rx/Tx control is provided by several relays connected to the PTT line.

The PSSU is a straightforward design using the "economy" configuration to produce both high and low voltage B+ from a single transformer winding. The supply also provides bias for the Rx and Tx circuits, and +24 VDC to operate the various relays. Two 4" speakers are

connected in series for the receive audio. A design feature of the PSSU and transceiver allows powering only those filaments required for the Rx functions to save tube life.

Additional Detailed Circuit Notes

Full schematic diagrams of the Octal Tri-Bander and PSSU are available on their respective pages at kg7tr.com, and should be referred to in this discussion. This information supplements the basic circuit descriptions provided in the Block Diagram Circuit Description section.

Schematic Sheet 1:

There are 22k “swamping” resistors switched across the selected coils for each band in the grid and plate circuits of V1. These resistors were found necessary to stabilize V1, which oscillated without them in place. There is nothing special about the design of this stage, and it is not much different from pentode RF amplifiers dating to the 1930s. There is adequate shielding between the coils, and since they are toroids, one would think shielding is not even required. After extensive troubleshooting and research, it was realized that the T50-2 toroids that are used have very high Qs (greater than 200 on 80 and 40 meters) compared to typical slug tuned coils used in vintage radios. The inter-electrode capacitances in V1, although quite small, were enough to cause the feedback and oscillation. The 22k resistors lower the Qs to less than 100, which stabilizes the stage on all bands. Swamping resistors are also connected across the toroids in the V16 circuit (the plate circuit of V16 is swamped by the 10k resistor connected across RFC4).

C5 and RFC1 form a trap to reduce the amount of 9 MHz signal coming into the front end. This is only a problem on 40 meters, where minimum settings of C1 will pick up the 9 MHz BFO carrier at the high end of the 40 meter band.

Coils L4-L6 (and L12-L14 and L15-L17 on sheet2) are shorted out by additional switch sections when not in use. It was discovered that series resonances with unused coils caused by stray capacitance was causing some problems. Again, it is felt this was due to the high Q of the coils.

Diode D1 was placed across the signal grid of V2 to clamp the maximum positive voltage to .6 volts. This grid should never go positive under any normal conditions due to the grid leak action of the capacitor feeding it, so the diode has no effect on normal operation. It was discovered that while changing bands, V2 would have its plate voltage interrupted but not its screen voltage. This would cause the tube to somehow lock up with a positive DC voltage on the signal grid. Testing elements of the tube with a scope did not reveal any kind of oscillation going on. Normal operation could be restored by keying the transmitter, which removes screen voltage but not plate voltage, or by shorting the signal grid to ground. I was unable to find any explanation of this phenomenon anywhere. It may be related to 9 MHz feedback mentioned above, although no such signal was observed on a scope. At any rate, the diode fixed the problem so it stayed.

As shown by L7 and other IF coils, several extra components were placed inside the coil cans and mounted to miniature terminal posts. This cut down on terminal strips and congestion in the chassis.

INRAD specifies an external 30 pf input and output capacitance for the FL1 filter. This filter does have some ripple across the passband. But putting capacitors across the input and output had almost no effect, so none are used.

C11 is peaked for maximum receiver gain. In the Tx mode circuit capacitances change a little, and re-peaking it will give a little more drive, but there is still plenty available so it stays at the receiver peak setting.

C12 is peaked for maximum audio at the plate of V6 with about a 1 KHz beat note on an incoming RF carrier of a few microvolts.

C13 is peaked for maximum S meter reading (i.e., maximum AGC voltage) with about 10 microvolts of RF input signal.

All other trimmers in the front end and IF are peaked for maximum S meter readings with appropriate RF input signals. On 80 meters it's necessary to check and optimize tracking over the band.

Relay K4 shorts out the grid of V8 in Tx to prevent an annoying "pop" in the speaker upon return to Rx. The 22 μ F capacitor across its coil holds the relay open when PTT is released to allow all other relays to change over before restoring audio. This includes the T/R relay in the linear. D17 prevents the capacitor from discharging into any other relay coils. Also note that in Rx mode, +24 volts is applied to the cathode of V13B to prevent microphone or tone oscillator feed through into any receiver stages.

If low impedance headphones (e.g., 8 ohms) are plugged into J1 an unacceptable 60 Hz hum may be present. Putting about 200 ohms in series with low impedance phones or using high impedance communications headphones will provide better results.

In the Tx mode, screen voltage is removed from V1 and V2 to kill these stages. Rx block bias is also applied to V1 and V4 via the AGC line when K2 is energized for Tx. In addition, the cathodes of V4 and V5 are open circuited when K3 (sheet 2) is energized for Tx. This prevents audio bleed through into the speaker from V4/V6 and adverse clipping action of V5 on the Tx SSB signal present at L9.

Schematic Sheet 2:

The transmitter circuits are pretty straightforward. Tx blocking bias is applied to the grids of V15, V17 and V18 in Rx mode via K2 contacts. In addition, voltage is removed from the screens of V16, V17 and V18 during Rx via K2 contacts. As a result of the Rx/Tx switching the load on the 250 volt B+ bus is pretty constant.

The ALC circuit consists of T2, D5, D6 and associated components. Audio frequency pulses of PA control grid current are sensed and stepped up by T2, rectified by the voltage doubler formed by D5 and D6, filtered for fast attack and hang time characteristics, and then applied to V3 in the Tx mode. ALC from a linear can also be applied at J3. T2 is from a Command receiver, and is reverse connected. The case is at the bias potential of the PA tubes, and is therefore insulated from the chassis.

Note the 300 pf and 620 pf bypass capacitors at S1R in the driver output circuit. The neutralization circuit used in this radio is very common in tube PAs. What is not generally stated about this circuit is that in its simplest form with a fixed bypass capacitance, neutralization is only ideal on one band and one setting of driver tank capacitance and inductance, where everything is in just the right amplitude and phase to null out the plate to grid feedback in the PA tubes. So without any type of compensation, C21 is usually adjusted on the highest band and you get what you get on the others. Of course bandswitching different values of C21 is totally impractical. It is entirely practical, however, to bandswitch other values of the bypass capacitance in the tank circuit of the driver. Since this bypass capacitance forms part of the

voltage divider that provides the magic voltages for neutralization, you can get the same results by changing it and leaving C21 alone.

So with some experimentation, it was determined that the extra capacitance added by S1R to the 1000 pf feedthrough bypass capacitor provided optimum neutralization on 40 and 80 meters. I have found that the easiest way to neutralize a PA is to adjust C21 for concurrent PA plate current dip and maximum power output into a dummy load. This was done for 20 meters as is the usual practice. Without the S1R compensating capacitors, the plate current dip and maximum power points for 40 and 80 were very squirrely and confusing. With the compensating capacitors in the circuit, the tuning is very well behaved on all bands. I was never able to find anything written about this technique, but was surprised to see it used in the HT-46, TR-4 and GSB-100 radios. There are probably others that use it too.

Also of note are that the screens of V16, V17 and V18 are returned to ground through high value resistors when screen voltage is removed from these tubes in the Rx mode. This also applies to the screens of V1 and V2 in the Tx mode. In looking at commercial transmitters I noticed that all of them either returned the PA screens to ground if voltage was removed for standby (e.g., Collins S-Line, Heathkit SB series), or they kept voltage on the screens (and plates too of course) and biased them off with blocking bias on the control grids (e.g., HT-32 and HT-37). It may not be an issue for the receiving type pentodes but they are drained to ground just in case.

On a related subject, D7 is in series with the screen voltage applied to the PA tubes. A long time ago I seem to remember reading something from Collins about the screens causing noise in the receiver during standby, but I can't find it today. At any rate, the diode is used in the KWM-2 and SB-100, so it's in this radio too.

The balanced modulator was originally implemented as a two diode series circuit working into a broadband ferrite transformer. This produced very poor carrier suppression. After much experimentation the four diode ring type circuit with tuned output was found to work best. This is basically the same circuit used in Collins S-Line, Heathkit SB series and Drake TR-4 radios.

The V12 BFO is a crystal oscillator using switch selected carrier crystals for LSB and USB. This was originally a tuned grid/tuned plate (TGTP) circuit using a 6J5 triode. In this configuration, which was very popular in phasing rigs of the era, tuning C24 for resonance in the plate tank changed the crystal frequency. In addition, going past resonance would cause oscillation to stop. These characteristics were of little consequence in those old phasing rigs, where the exact frequency of oscillation was not particularly critical. However, in a filter rig it is very annoying when trying to set the carrier frequency down a steep filter slope. Changing to a Colpitts circuit with a 6SK7 pentode eliminated these interactions.

Attempting to set the audio bandpass in the Tx mode by adjusting carrier frequency (using C25 and C26) is a very confusing affair filled with compromises. As a much easier method, I finally ended up setting the carrier on each sideband about 20 db down the filter slope on Rx. Of course with filter ripple, determining exactly where the peak is can be subjective. And each time the carrier frequency is tweaked, the offset adjustments in the frequency counter have to be redone. The unused crystal is shorted out by S3B, again after noting some interaction at certain settings of the trimmer capacitors with the unused crystal floating.

Operation of V14 is pretty basic. When the FUNCTION switch is in TUNE or LOCK KEY, K5 is energized. This grounds the cathode circuit of V14 and connects its output to the MIC GAIN control. With the cathode circuit completed, V14 oscillates to generate a tune up tone. The theoretical frequency for a three stage RC oscillator like this is 1,640 Hz, but component

tolerances and actual circuit loads bring it down to a measured value of about 1,250 Hz. R5 is adjusted to get the flattest RF output signal (i.e., single tone) on a scope, indicating a good sine wave output from V14.

Schematic Sheet 3:

V9 is used in a classic Colpitts circuit to generate the 5 MHz VFO signal. A small “antenna” placed next to L22 inside the shield provides enough signal to reliably trigger the display counter. A very clean sine wave at the cathode of V9 is coupled to V10 through a small capacitor.

V10 is used as a mixer or a buffer depending on the band. The 6AC7 is an octal version of the 6AH6. The latter tube is used as a mixer in several Hallicrafters sideband transmitters and the Gonsett GSB-100. Extensive breadboard experiments showed that it was a good tube to use in this radio as well.

For 80 and 20 meters, V10 is just a buffer whose 5.0 to 5.5 MHz output is bandpass tuned by L23 and L24, and their parallel capacitors and trimmers C32 and C33. For 40 meters, V11B is turned on by the bandswitch and a 21.5 MHz signal appears at its output across L27. This is loosely coupled to V10, where it combines with the VFO signal to cause a mixing action. The desired output is in the 16.0 to 16.5 MHz range, and is bandpass tuned by L25, C34, L26 and C35. Unfortunately the third harmonic of the VFO signal will fall into this range for frequencies higher than 5.33 MHz. RFC9 and C30 form a 16 MHz trap to keep these signals out of V10. By careful experimentation the circuit values used produce a reasonably clean signal to the Rx and Tx mixers on 40 meters. No objectionable birdies have been found in the 7.0 to 7.3 MHz region of 40 meters.

Adjustment of the bandpass filters was very time consuming, and required many excursions of VFO frequency. To make things easier, the worm drive gear on C27 was temporarily removed and replaced with a large knob. Then the frequency was varied back and forth to get a decently flat injection voltage into the mixers. The 10k resistors in the bandpass circuits help flatten things out.

The NorCal FCC-1 frequency counter is documented online. (NOTE: After much searching, I was finally able to locate a drop in replacement LCD display for this counter that is backlit. See later paragraph for modifications.) U1 provides +12 volts to the counter. This unit is no longer available from the NorCal QRP group. It does require programming a fixed IF offset frequency for each band, and you only get one offset per band. Because of this, it was necessary to select the offset for the “normal” sideband (i.e., LSB on 80 and 40, USB on 20). In reverse sideband operation the readout will be in error by the difference between the two carrier crystals (about 3 KHz). A better implementation for the display would be to use a counter that can accept two oscillators. That way adjusting the BFO or the 21.5 MHz oscillator would not have any effect on the reading. It would, however, require routing a sample of the mixer injection voltage from V10 up to the counter in addition to the VFO signal.

The metering circuits for plate and grid current are straightforward. For the S meter/ALC function, a sample of the voltage at the cathode of V3 is connected to the negative side of the meter and a sample of the screen voltage is connected to the positive side. AGC or ALC voltage at the control grid of V3 becomes more negative as Rx signal strength or Tx PA grid current increases. This causes V3’s cathode voltage to decrease and screen voltage to increase. By connecting these two variable voltages to opposite sides of the meter, a very sensitive indicator

can be implemented. The 330 ohm resistor in the circuit sets the S meter calibration at a reasonable reading for S9 at slightly above midscale, and above S9 to a maximum of about +50 db full scale.

Two zero pots are used, one for AGC and the other for ALC, to accommodate minor differences between Rx and Tx. These are switched by K6. They probably could have been omitted. When the meter switch is in PLATE or GRID, the S meter does not function. Furthermore, in these positions the ALC voltage is grounded so that it will not interfere with tuning up the PA. After tune-up the switch is returned to S/ALC for normal operation.

All relays are powered from a regulated 24 VDC source. The filaments are arranged in two strings, one for Rx and one for Tx. In this way it is possible to power, via PSSU toggle switch, only the filaments needed for RX. It was mostly a coincidence, but the Rx filaments and Tx filaments worked out to about 4.4 amps each. This came in handy early on, as I was able to use the 12.6 VAC filament voltage from a Heathkit HP-23B power supply by connecting both strings in series. That way I was able to delay building the PSSU until the transceiver was up and running.

Schematic Sheet 4:

The power supply is a typical transceiver design using the “economy” circuit. A single plate transformer is used to generate nominal 800 volts B+ for the PA tubes and 250 volts B+ for all the other circuits. For the high voltage, D1 through D8 form a full wave bridge rectifier that works into a capacitor input filter consisting of three 220 μ F electrolytics in series. The 100k resistors serve as bleeders and also equalize the voltage across each capacitor. For the low voltage, D5 through D8 form a full wave center tapped rectifier that feeds a choke input filter. Some economy supplies use a capacitor input filter here as well, but for this radio that would have produced way too much B+ for the low voltage circuits. The choke input used here yields about +250 volts under both Rx and Tx load conditions with minimal ripple. The 100k resistor acts as a bleeder.

T1 was a hamfest find that was made by a company called Wahlgren. It has some weird specs like a 111 VAC, 50-700 Hz primary, but it felt heavy enough to do the job. The power supply was breadboarded first and thoroughly tested at 120 VAC input. T1 works just fine in this application – no hum, no noticeable temperature rise, and good regulation of output voltages.

T2 is rated at 10 amps and gets slightly warm under full load. As described previously, S2 allows powering only receiver filaments if desired.

T3 works into a full wave bridge rectifier to produce nominal 35 volts input to U1, a 24 VDC IC regulator. The resulting 24 volts powers all transceiver relays as well as the display (the latter through a 12 volt regulator in the transceiver). T4 is reverse connected, half wave rectified and filtered to provide nominal -120 volts bias voltage.

Digital Display Upgrade

While the NorCal FCC-1 counter kit works well for this radio, I have always thought it really needed a backlit display. The original display module supplied with the kit is unlit, making it hard to read in a darkened room. It was made by a Chinese company called Xiamen Ocular. Although online datasheets suggest Xiamen Ocular made a backlit version, I was unable to find any supplier for it. In addition, that display is narrower than the common 16 x 2 backlit LCD displays available today. Trying to retrofit one of those wider displays would require hacking up the front panel of the radio, plus it wouldn't easily fit to the counter board.

So I assumed I was out of luck for an easy solution. But after extensive internet searches and plain chance, I discovered that another company, New Haven Displays (NHD), was making the exact same display module in both backlit and unlit versions. And it was available from several sources including Mouser Electronics. So I bought two of them.

The NHD module was a drop in replacement. But the backlight does require about 80 to 100 ma of current at 5 volts to light it up. This in turn required modifications to the PSSU to deliver the extra current. The changes included: 1) Replacing T3 with a larger transformer and mounting it topside, 2) Replacing the voltage doubler with a full wave bridge, and feeding its output to a 24 VDC IC regulator. The transceiver was modified to use a 12 VDC IC regulator to power the counter module and its new backlight. The backlight itself was powered off the counter's reverse polarity protection diode (D2 on NorCal's schematic) through an 82 ohm dropping resistor to keep the current at about 90 ma.

If you have one of these counters and are interested in the backlight upgrade, the NHD part number is NHD-0216HZ-FL-YBW-C. Be sure to procure the "C" suffix. Mouser has them, as well as Digi-Key and Newark. And check the associated datasheet to make sure the dimensions match the display you have.



Figure 1: The Octal Tri-Bander Transceiver



Figure 2: The Power Supply/Speaker Unit (PSSU)

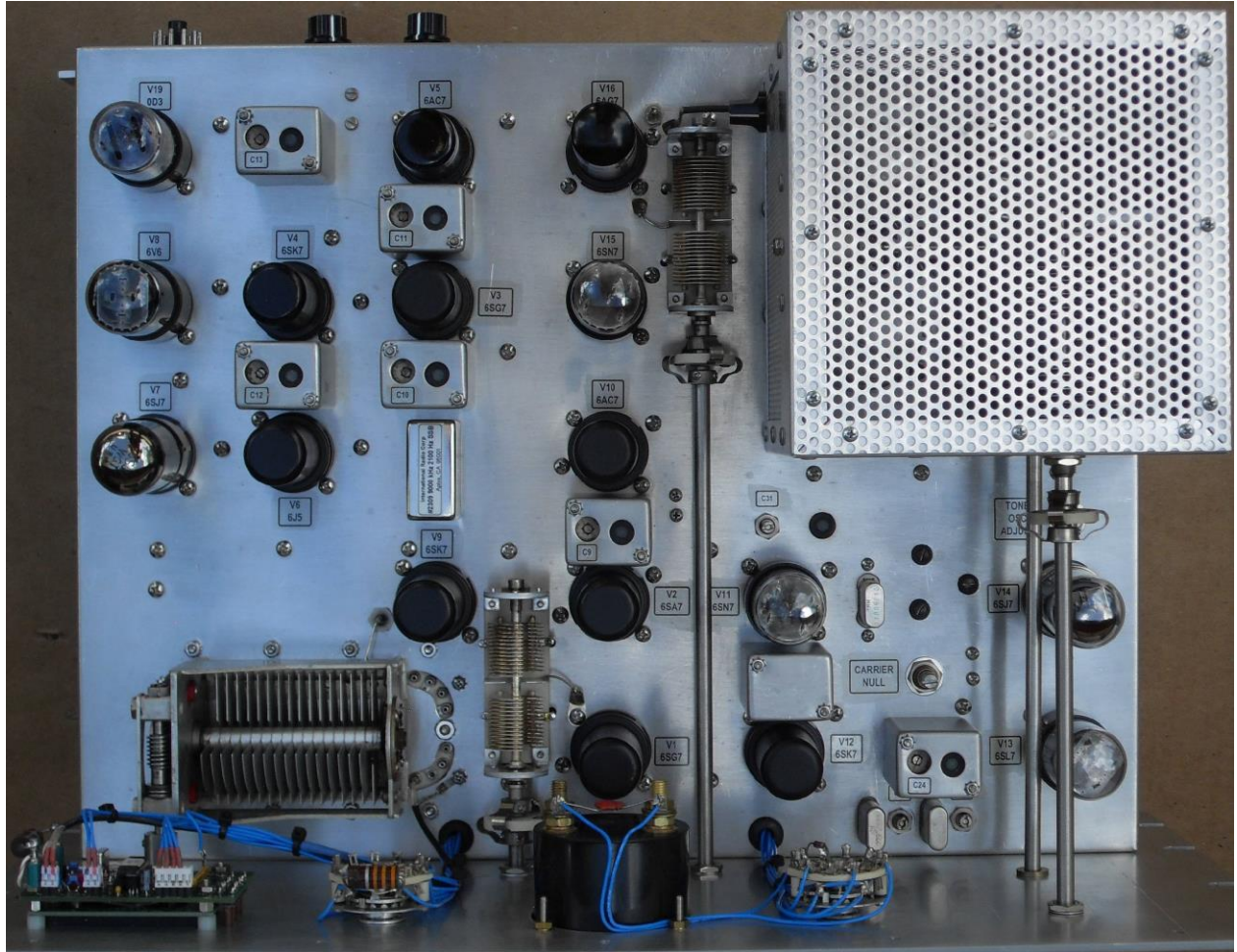

Figure 3: Transceiver Top View

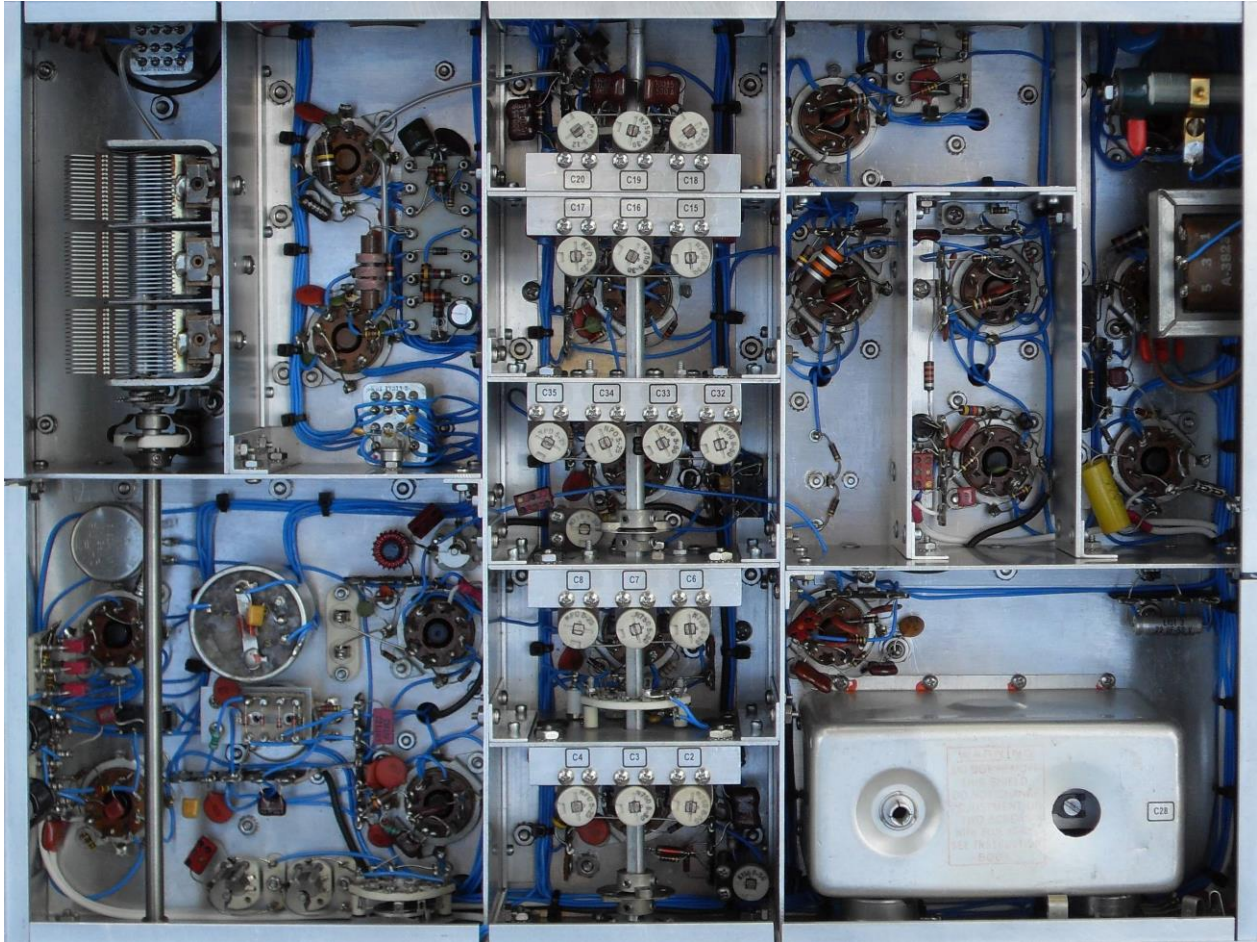

Figure 4: Transceiver Bottom View

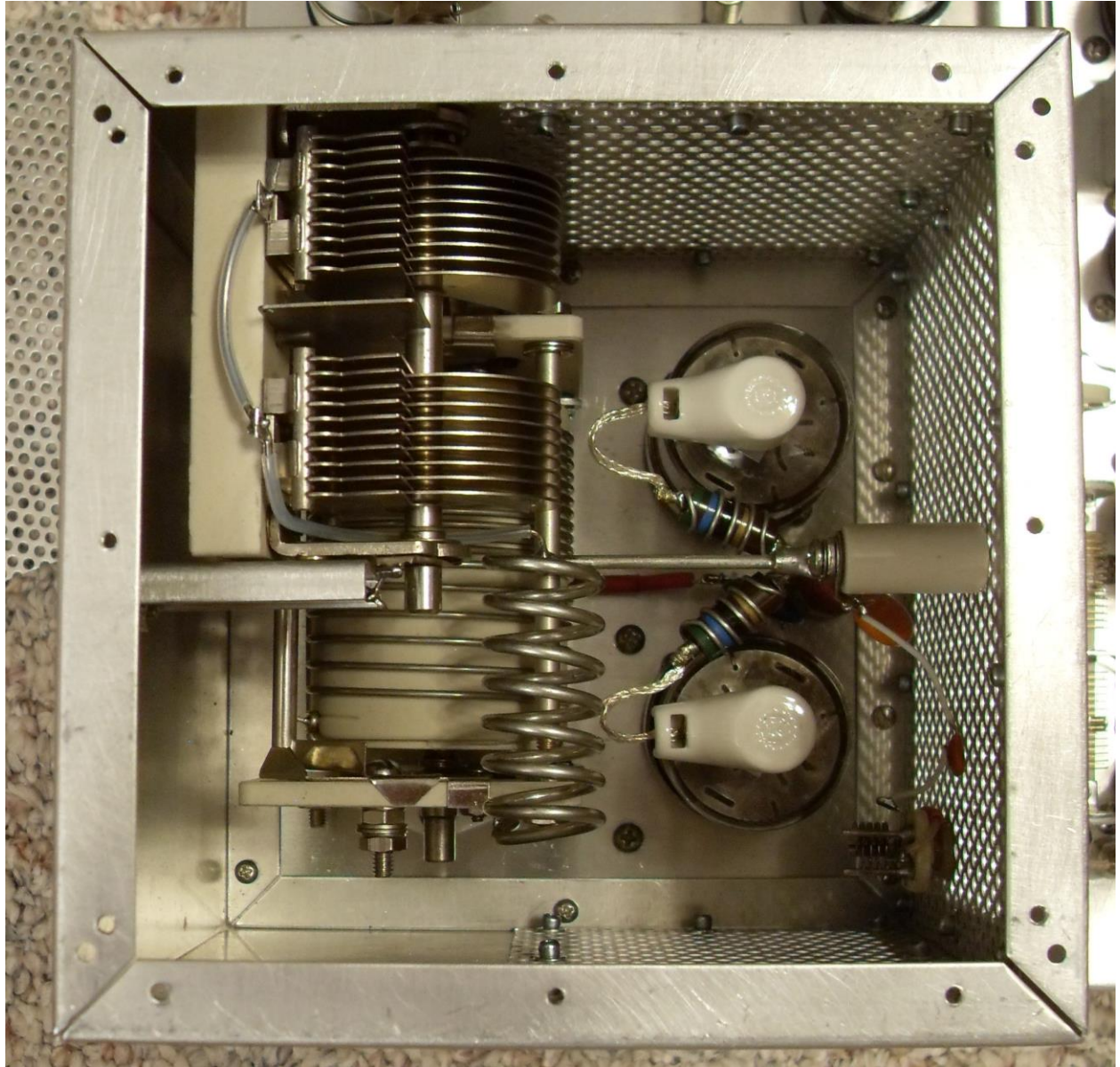

Figure 5: Interior of PA Cage

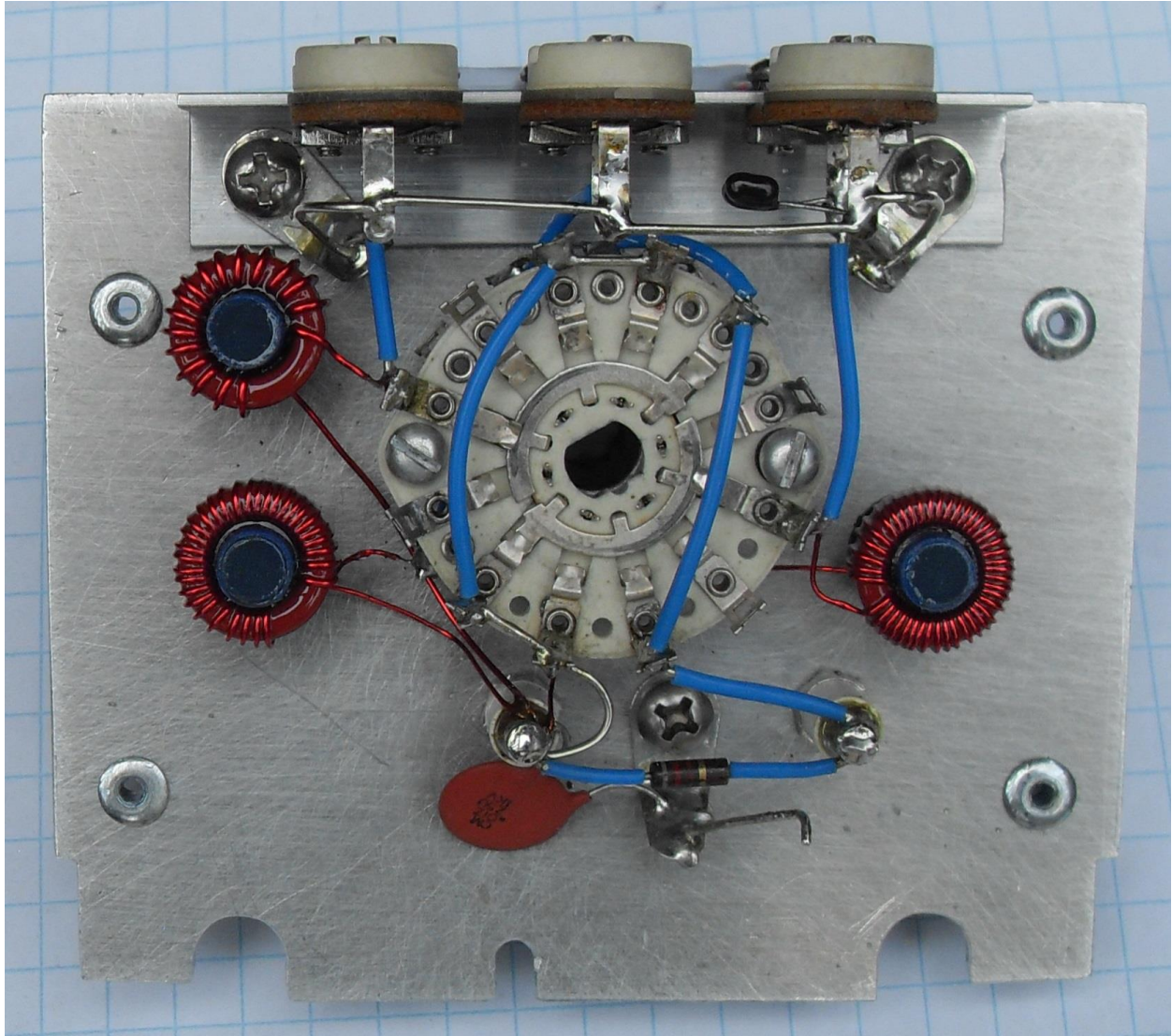

Figure 6: Typical Removable Bandswitch Section



Figure 7: Rear View of Transceiver

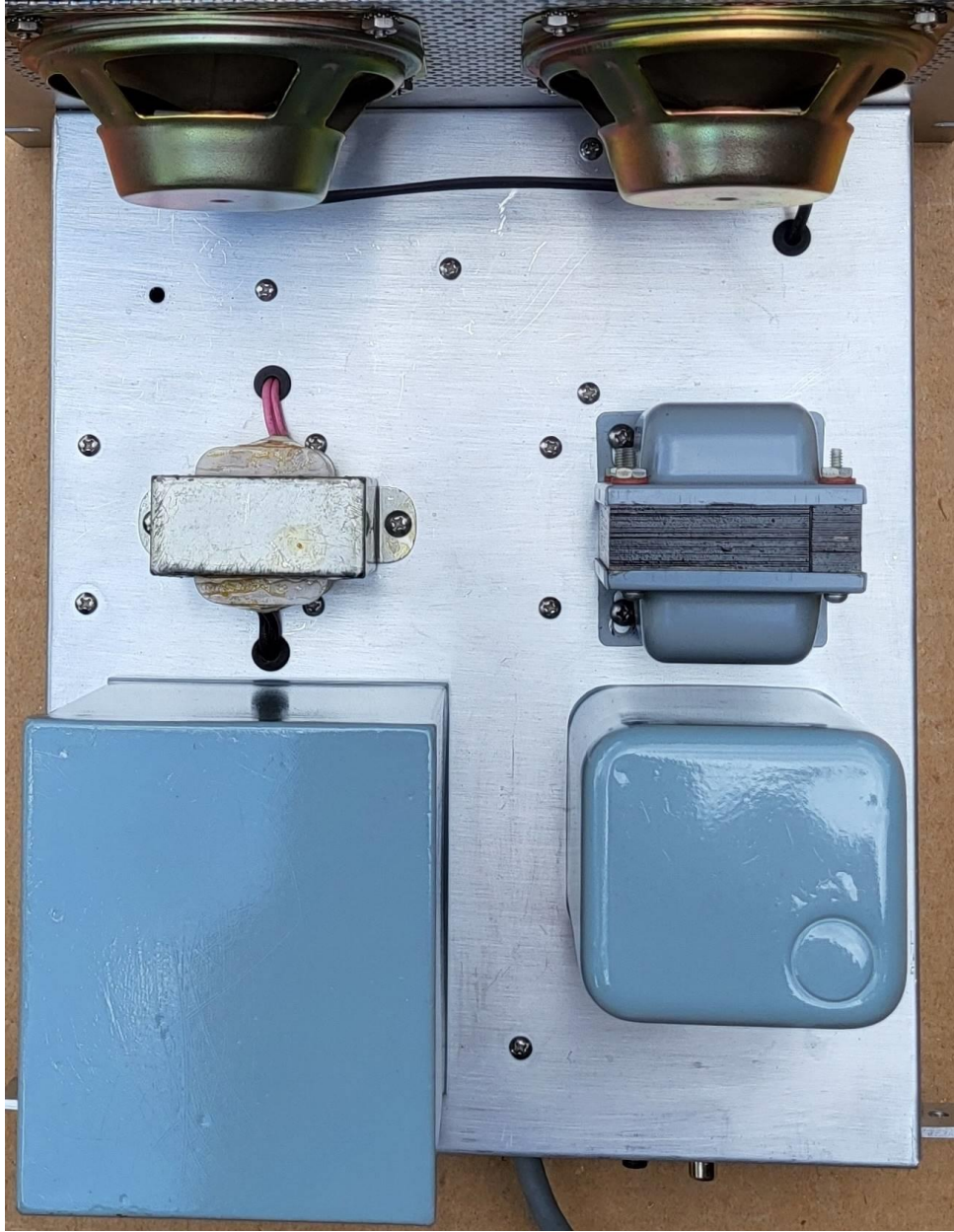

Figure 8: PSSU Top View

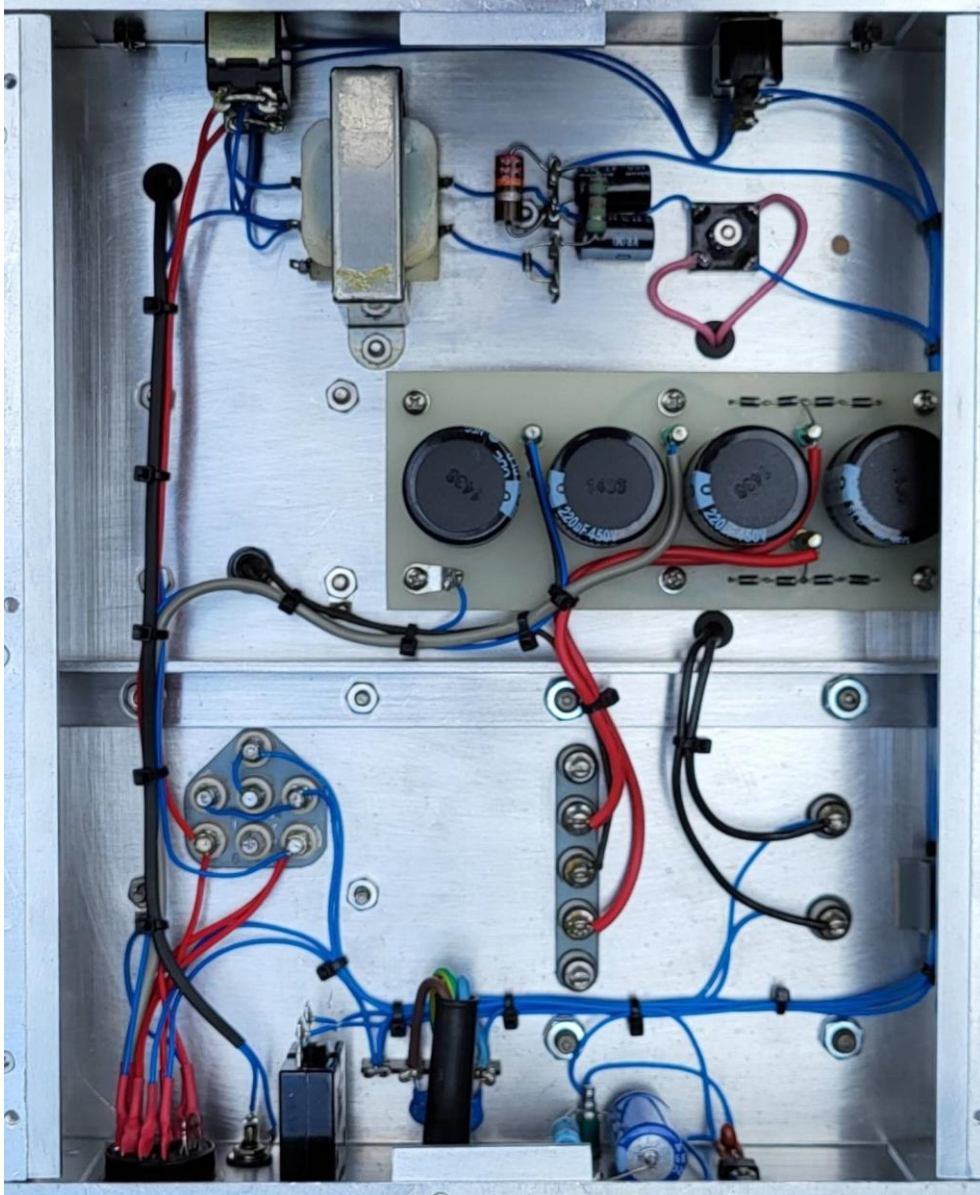
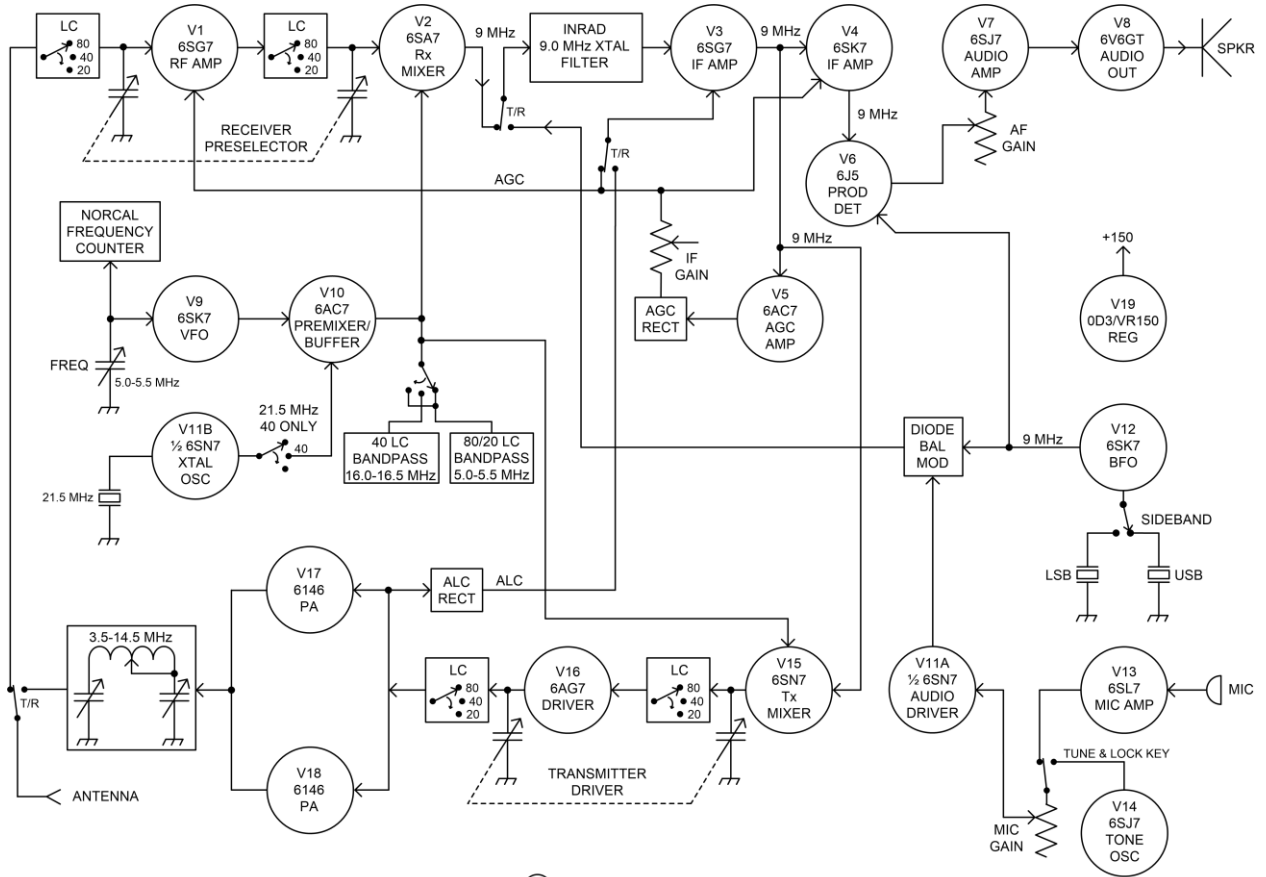

Figure 9: PSSU Bottom View



CTAL TRI-BANDER BLOCK DIAGRAM
100 WATT SSB TRANSCEIVER

HOMEBREWED BY KG7TR REVISION 11 MARCH 2020

Figure 9: Transceiver Block Diagram