

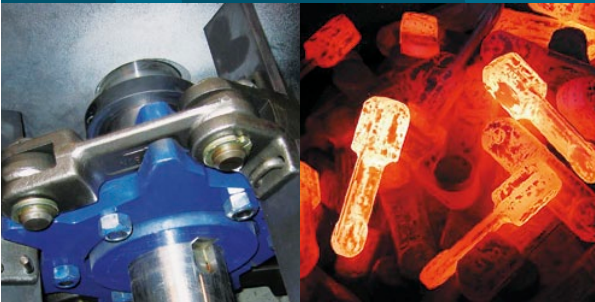

FORGED CHAINS



 *Linking you to EXCELLENCE since 1926*

JOHN KING



JOHN KING & COMPANY

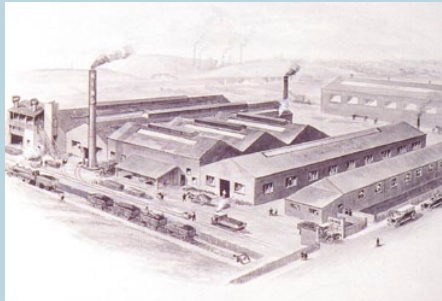

Climax Works 1930's



Chain Assembly 1960's



New Climax Works 2000's

Company History and Qualifications

The John King Company was established in Leeds, England in 1926. Early success was achieved in the manufacture of mechanical handling equipment for the rapid mechanisation of the coal industry. In these early days conveyor chain was generally of cast link construction. The Company therefore has unrivalled experience in the production of highest quality cast link chains in ductile irons and steel under the "Climax Quality Brand". JOHN KING are undoubtedly the world leaders in this range of conveying chains.

Although cast link chains remain an important part of the JOHN KING programme, the company has progressively expanded the product range to encompass chains of other constructions and manufacturing techniques including Welded steel chains, engineered steel chains, forged fork link chains and Engineering plastic chains.

Today JOHN KING offer the widest range of conveyor chains of any manufacturer which makes them unique in being able to offer an infinite number of chain types in a variety of materials and constructions for a multiplicity of industry mechanical handling applications.

In recent years it has been JOHN KING's strategy to develop the Company into a global business. This has seen the establishment, in addition to the main factory in England, distribution Companies in North and South America, Africa, South East Asia and Central Europe. Our objective is to provide best service in supply of high quality chain and sprockets Worldwide.

All products are manufactured within the dictates of the Company's quality management according to ISO 9000 establishing consistent and high quality products and ensuring performance reliability and extended service life.

We are pleased to present our Forged Fork Link catalogue detailing the most comprehensive range of chains of this series together with ancillary equipment including sprockets, idlers, wear rails and flight bars in the market. We look forward to working with you in the future.

CONTENTS

Forged Link Standard Series **03** | Forged Link Double Series **04** | Forged Link Triple Series **05** | High Manganese Wear Rail **05** | Plastic Sleeves for Standard Forged Chains **06** | Engineering Plastic Flight – TUFFLEX® with Unique Mounting Arrangement (Patent Pending) **06** | Bushing **06** | Pin styles **07** | Flight attachment options **08** | Material specification **10** | Segmental Sprockets Hubs **11**

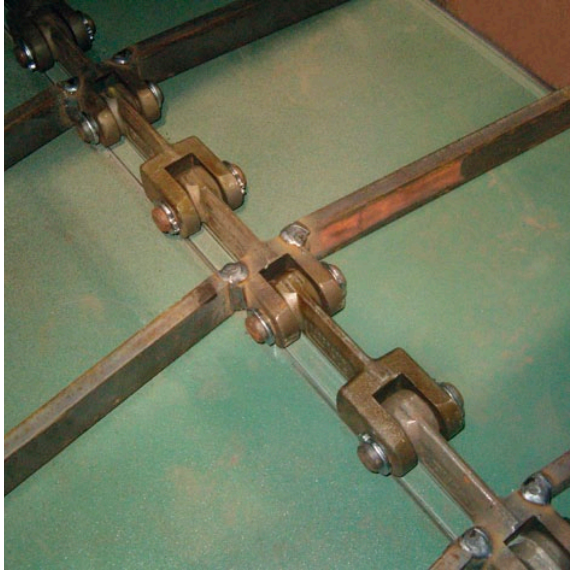

Forged Link Standard Series

This series represents the leading product within the John King programme. Forged fork link chain has proven to be one of the most reliable conveying mediums offering a combination of versatility, strength and abrasion resistance. These chains, originally of European origin, are now established worldwide. With a wide variety of materials, heat treatments and flight formats the chain is proven in both drag and enmasse handling.

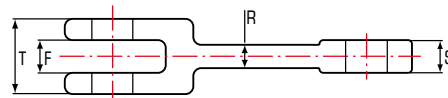
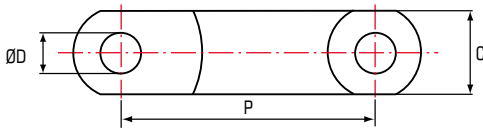

Forged Link Standard Series

Chain Number	P	T	C	S	F	R	Bolt Hole Diameter	Breaking Loads			Weight
								D	TN*	CN*	
								mm			kg/m
JKF 10160	101.6	24	36	8	10	6	14	110	120	210	3.50
JKF 10160R	101.6	30	36	13	14	9	14	180	195	330	4.80
JKF 12514	125	30	36	13	14	10	16	163	175	290	4.40
JKF 14214	142	30	40	13	14	9	18	180	195	330	4.90
JKF 14218	142	42	50	19	20	11	25	290	320	550	9.40
JKF 14222	142	54	50	25	27	16	25	370	400	655	12.20
JKF 14226	142	62	50	28	30	15	25	440	470	790	13.60
JKF 16018	160	46	46	22	24	15	22	320	342	560	9.30
JKF 16025	160	50	53	23	25	13	25	370	400	655	10.80
JKF 20025	200	60	50	25	27	18	25	380	410	670	11.30
JKF 20028	200	66	60	30	32	20	30	500	540	900	16.70
JKF 21640	216	64	72	26	28	20	35	585	630	1035	20.10
JKF 22040	220	64	72	26	28	20	35	585	630	1035	20.30
JKF 22050	220	58	75	28	30	25	32	710	760	1260	19.10
JKF 22060	220	71	75	31	33	21	35	735	790	1300	22.90
JKF 25040	250	70	75	32	34	18	32	735	860	1430	18.80
JKF 26035	260	65	75	31	33	20	32	840	900	1480	19.80
JKF 26040	260	70	75	31	33	20	32	840	900	1480	21.00
JKF 26045	260	78	75	35	37	20	32	930	1000	1650	21.80

* For further information on TN, CN and CD materials refer page 10.

Forged Chains



Forged Link Double Series

For double strand assemblies John King have a range of links following the standard format but with a forged "double clevis" into which a scraper can be mounted. The flight blade can be retained by either a U bolt or standard fasteners. The chain allows for some built in clearance between strands which obviates any potential problems that may be associated with mismatch. Double strand allows for improved discharge particularly relevant in conveying sticky materials.

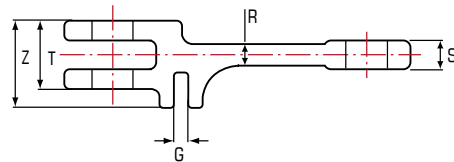
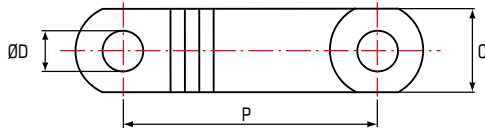

Forged Link Double Series

Chain Number	P	T	C	S	Z	G	Bolt Hole Diameter D	Breaking Loads			Weight kg/m
								TN*	CN*	CD*	
mm											
JKF 142182	142	42	50	19	70	13	25	290	320	550	11.80
JKF 142262	142	62	50	28	87	13	25	440	470	790	16.70
JKF 160252	160	50	53	23	82	13	25	370	400	655	13.60
JKF 175402	175	72	60	30	95	16	30	540	580	955	20.30
JKF 200252	200	60	50	25	81	12	25	380	410	670	13.00
JKF 200402	200	70	60	30	95	13	30	540	580	955	19.30
JKF 250252	250	60	50	25	81	12	25	380	410	670	12.00
JKF 250402	250	70	60	30	95	13	30	540	580	955	17.70
JKF 250602	250	100	70	45	140	21	35	975	1050	1720	35.20

Attachment hole positions and sizes can be varied to meet customer requirements. Dimensions in metric measure.
* For further information on TN, CN and CD materials refer page 10.

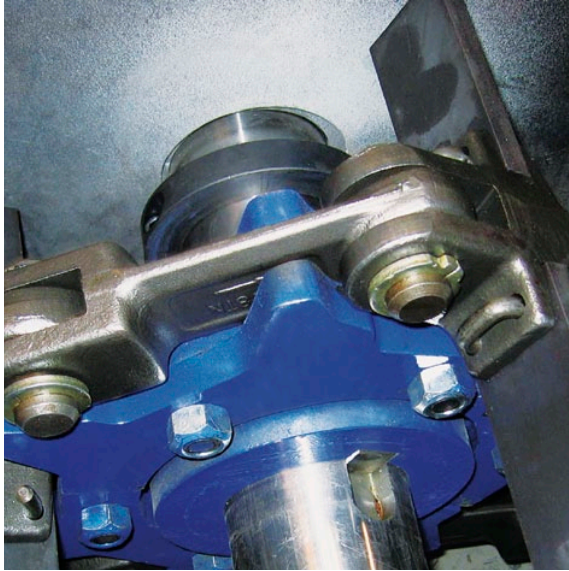

Forged Link Triple Series

Where extra wide flights are required the John King triple link is available allowing, in conjunction with the double on perimeters, three chain strands up to 3100 mm overall. In addition the "Double slot" allows for a versatile means or flight retention for both steel & plastic options. Retention can be either U clips or standard fasteners.

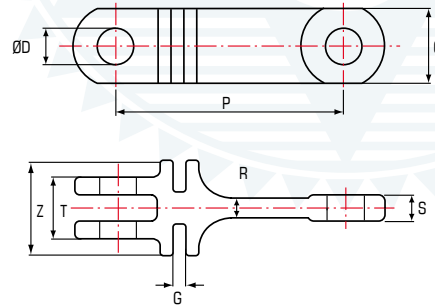

Forged Link Triple Series

Chain Number	P	T	C	S	Z	G	Bolt Hole Diameter D	Breaking Loads			Weight kg/m	
								TN*	CN*	CD*		
	mm								kN			
JKF 142183	142	42	50	19	92	13	25	290	320	550	14.20	
JKF 142263	142	62	50	28	112.3	13	25	440	470	790	19.80	

Attachment hole positions and sizes can be varied to meet customer requirements. Dimensions in metric measure.
* For further information on TN, CN and CD materials refer page 10.

High Manganese Wear Rail

The standard recommendation for forged chain wear rail is manganese steel, an austenitic structure, offering unique work hardening properties. In its rolled condition it offers a hardness value of 200-220 Bnh increasing up to 600 Bnh if the optimum conditions prevail.

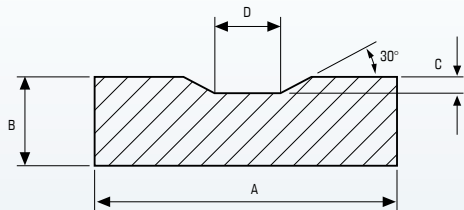

Material	DIN	Hardness	Standard Length
120mn12	1.3401	200-220 Bnh	3000mm -0/+5

	A	B	C	D
	mm			
49/2510	25.0	10.0	2.0	5.0
49/4010	40.0	10.0	2.0	5.0
49/5010	50.0	10.0	2.0	5.0
49/6012	60.0	12.0	3.0	6.0
49/6020	60.0	20.0	3.0	6.0

Forged Chains

Plastic Sleeves for Standard Forged Chains

Flight Material

- Extruded UHMW Polyethylene.

All measurements in mm.

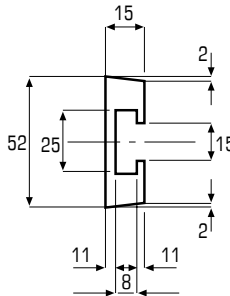
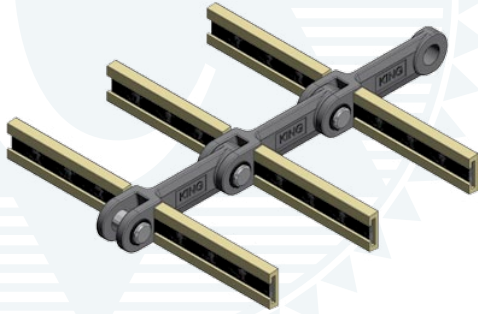

10160
10160R

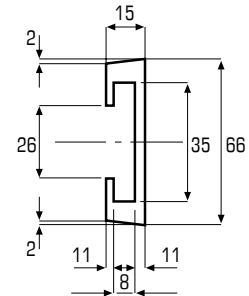

14218
14226

Engineering Plastic Flight – TUFFLEX® with Unique Mounting Arrangement (Patent Pending)

Flight Material

- High Impact Resistant Engineering Plastic (For options refer to our technicians)

Flight No.	Max Width	
	inches	mm
10160R	15.50	395
14218	29	740
14226	30	760

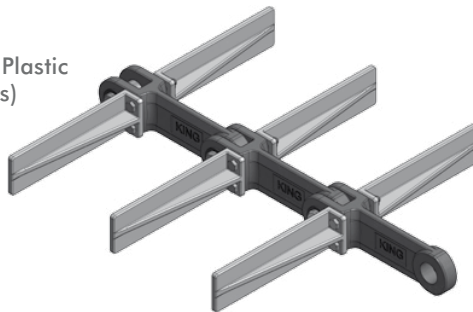

Bushing

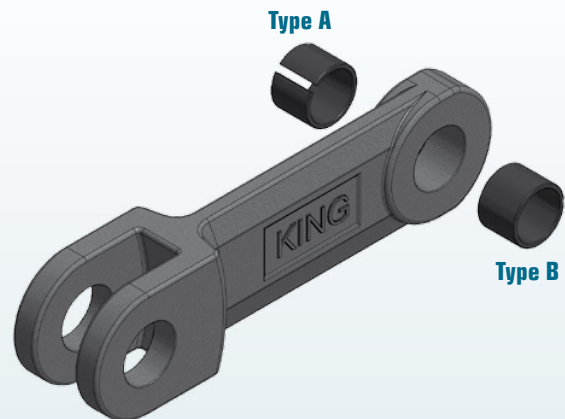
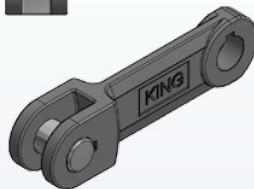
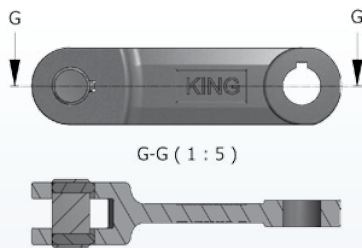

Type SN2 – Flush style antirotation pin

Links can be machined to accommodate liner bushes. These can be in solid or split form. Material options include heat treatable Stainless Steel or Hardened Alloy Steel dependant on the wear and/or corrosion characteristics desired.

For further information on materials refer page 10.

Pin styles

Type 22 – Standard double circlip

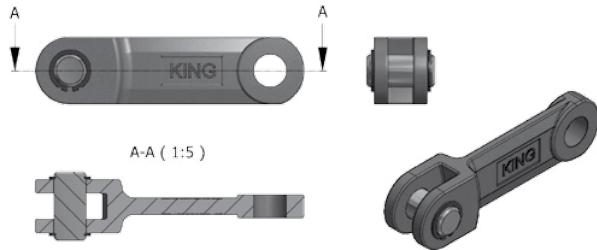

Type HD/22 – Headed pin with standard circlip

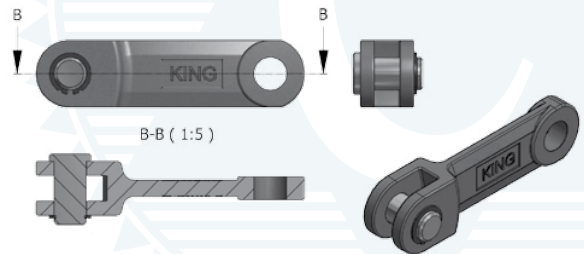

Type HD/45/28RP – Headed pin with collar and roll pin retention

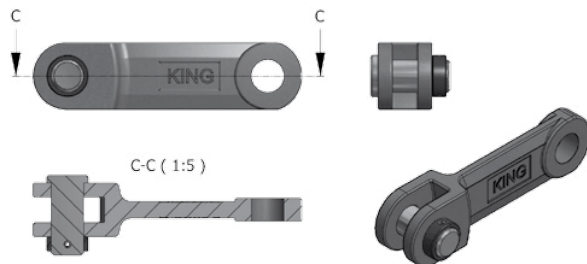

Type HD/45/28S – Headed pin with collar and S cotter retention

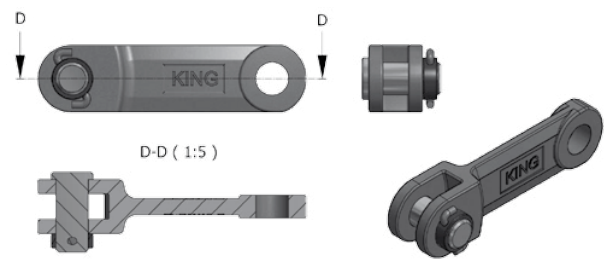

Type SN/28S – Antirotation snub pin washer and S cotter retention

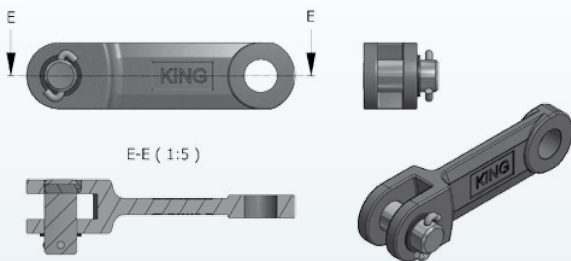

Type HD/28S – Headed pin with washer and S cotter retention

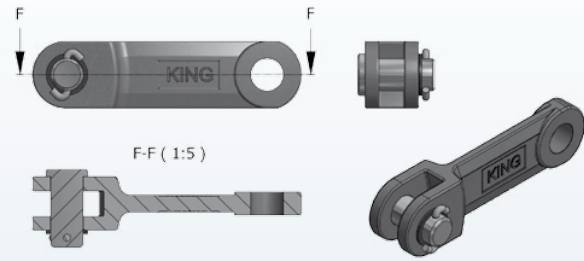

Note: Where S cotters are employed split cotters can be used as an alternative.

Forged Chains

Flight attachment options

B Type Flight Attachments for Horizontal Conveying



T Type Attachments for Horizontal and Slightly Inclined Conveying

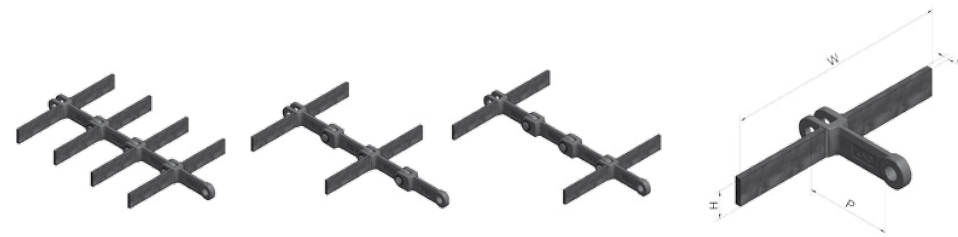

U Type Attachments for Horizontal and Inclined Conveying (with or without blanking plate)

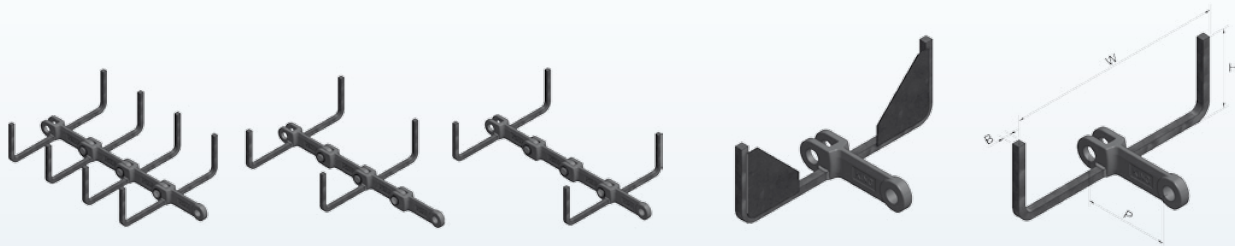

C Type Attachments for Horizontal, Inclined and Vertical Conveying (with or without blanking plate)



OO Type Attachments for Horizontal and Inclined Conveying (with or without blanking plate)

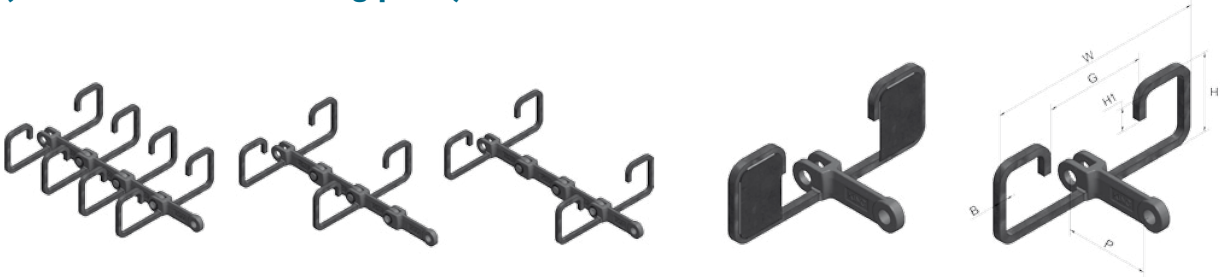

Double Series Flight Options I Format

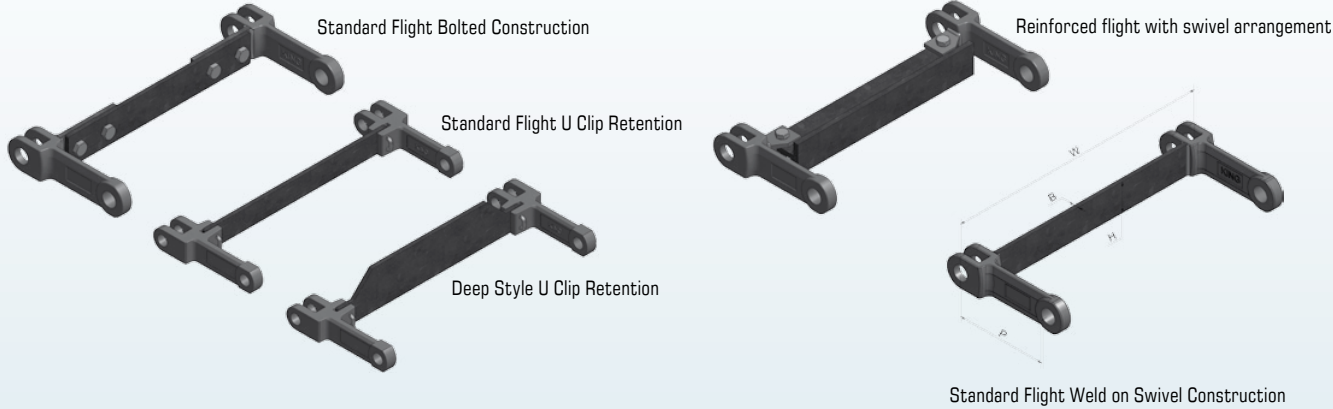

Forged Chains

Material specification

DROP FORGED CHAIN LINKS

Material reference	JK Reference	Material No		Standard Hardening	JK Heat Treatment Designation	Standard hardening value	Standard hardening depth
		DIN	AISI				
STANDARD QUALITIES							
C45	C	1.0503	1045	HARDENING AND TEMPERING	TH	800-900 N/mm ²	
20 MN CR 5	TN	1.7147	5120	CASE HARDENING	CH	58-62 HRC	0,8-1,0 mm
21 NI CR MO 4	CN	1.6523	8620H	CASE HARDENING	CH	58-62 HRC	0,8-1,0 mm
42 CR MO 4	CD	1.7225	4140	HARDENING AND TEMPERING	TH	1100-1300 N/mm ²	
CORROSION AND ACID RESISTANT MATERIAL							
X 5 CR NI 18-10 (V 2 A)	SS304	1.4301	304				
X 6 CR NI MO TI 17-12 2 (V 4 A)	SS316	1.4571	316				
X 46 CR 13	SS 420	1.4034	420	HARDENING AND TEMPERING	TH	40-45 HRC	
HEAT – RESISTANT MATERIAL							
X 10 CR AL SI 7	JK HK	1.4713		HEAT RESISTANCE IN AIR 800° C MAX		420-620 N/mm ²	
X 15 CR NI SI 20-12	JK HH	1.4828	309	1000°C MAX		500-750 N/mm ²	

CHAIN PINS

Material reference	JK Reference	Material No		Standard Hardening	JK Heat Treatment Designation	Standard hardening value	Standard hardening depth
		DIN	AISI				
STANDARD QUALITIES							
	BS970 1991						
16 MN CR 5	590M17	1.7131	5115	CASE HARDENING	CH	58-62 HRC	0,8-1,0 mm
15 NI CR 13	633M13	1.5752	3310	CASE HARDENING	CH	58-62 HRC	0,8-1,0 mm
18 CR NI 8		1.592		CASE HARDENING	CH	58-62 HRC	0,8-1,0 mm
C 45	080M46	1.0503	1045	INDUCTION HARDENING	IH	52-56 HRC	1,5-2,0 mm
				HARDENING AND TEMPERING	TH	45-50 HRC	
42 CR MO 4	708M40	1.7225	4140	INDUCTION HARDENING	IH	56-60 HRC	1,5-2,0 mm
				HARDENING AND TEMPERING	TH	56-60HRC	
CORROSION AND ACID RESISTANT MATERIAL							
X 46 CR 13	420S29	1.4034	420	INDUCTION HARDENING	IH	50-55 HRC	1,5-2,0 mm
				HARDENING AND TEMPERING	TH	45-50 HRC	
X 105 CR MO 17	440S49	1.4125	440	INDUCTION HARDENING	IH	58-62 HRC	1,5-2,0 mm
				HARDENING AND TEMPERING	TH	58-62 HRC	

CIRCLIPS

Material reference	JK Reference	Material No		Standard Hardening	JK Heat Treatment Designation	Standard hardening value	Standard hardening depth
		DIN	AISI				
STANDARD QUALITIES							
DD12	P12	1.0398	621				
Ferritic – Cromweld 3Cr12	SS410	1.4003	410				
Austenitic	SS304	1.4301	303				

BUSHES

Material reference	JK Reference	Material No		Standard Hardening	JK Heat Treatment Designation	Standard hardening value	Standard hardening depth
		DIN	AISI				
STANDARD QUALITIES							
C 67 S	070A72	1.1231	1070	HARDENING AND TEMPERING	TH	420-500 HV	
55 SI 7		1.5026	9255	HARDENING AND TEMPERING	TH	410-500 HV	
CORROSION AND ACID RESISTANT MATERIAL							
X 5 CR NI 18-10 (V 2 A)	SS304	1.4301	304				
X 6 CR NI MO TI 17-12 2 (V 4 A)	SS316	1.4571	316				
X 46 CR 13	SS420	1.4034	420	HARDENING AND TEMPERING	TH	42-49 HRC	
X 7 CR NI AL 17-7	SS630	1.4568	630	PRECIPITATION HARDENING	PH	400-480 HV	

CHAIN FLIGHTS

Material reference	JK Reference	Material No		Standard Hardening	JK Heat Treatment Designation	Standard hardening value	Standard hardening depth
		DIN	AISI				
STANDARD QUALITIES							
S 235 JR	S235	1.0038	1018				
S 355 J2	S355	1.0577	1036				
C 45	080M46	1.0503	1045				
AR400	HP400	XAR400		HARDENING AND TEMPERING	TH	400 Bnh	
AR500	HP500	XAR500		HARDENING AND TEMPERING	TH	500 Bnh	
CORROSION AND ACID RESISTANT MATERIAL							
X 5 CR NI 18-10 (V 2 A)	SS304	1.4301	304				
X 6 CR NI MO TI 17-12-2 (V 4 A)	SS316	1.4571	316				
HEAT – RESISTANT MATERIAL							
X 10 CR AL SI 7	JKHK	1.4713		HEAT RESISTANCE IN AIR MAX 800°C			
X 15 CR NI SI 20-12	JKHH	1.4828	310	MAX 1200°C			

SPROCKET SEGMENTS

Material reference	JK Reference	Material No		Heat Treatment	JK Heat Treatment Designation	Maximum surface Hardness (hrc)
		DIN	AISI			
C45	080M46	1.0503	1045	INDUCTION HARDENED	IH	60 (3±2mm)
34 CR MO 4	708A37	1.7220	4135	INDUCTION HARDENED	IH	57 (3±2 mm)
42 CR MO 4	708A42	1.7225	4142	INDUCTION HARDENED	IH	61 (3±2 mm)

IDLER WHEEL

Material reference	JK Reference	Material No		Heat Treatment	JK Heat Treatment Designation	Maximum surface Hardness (hrc)
		DIN	AISI			
C45	080M46	1.0503	1045	INDUCTION HARDENED	IH	60 (3±2 mm)

Segmental Sprockets & Hubs

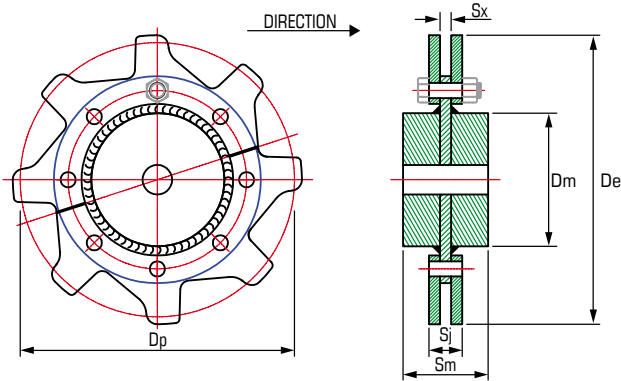

Standard Asymmetrical Pattern

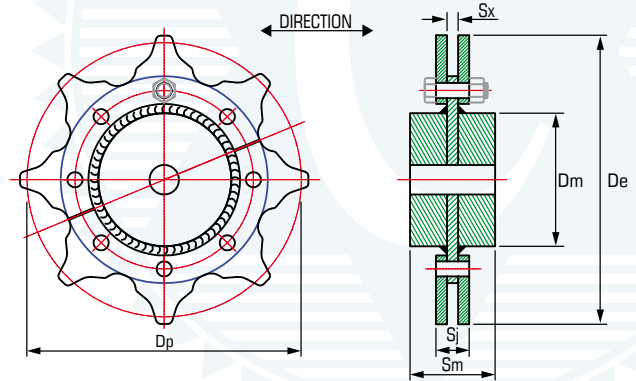

Reversible Pattern

Segmental Sprockets & Hubs

JK code	No of Teeth	Dp	De	Dm max	Sj	Sx	Sm
10160 10160R*	6	203.20	216	80	34	10	90
	8	265.49	277	120	34	10	90
	10	328.78	340	160	34	10	110
	12	392.55	404	180	34	10	115
	14	456.58	468	200	34	10	140
	6	203.20	216	80	36*	12*	90
	8	265.49	277	120	36*	12*	90
	10	328.78	340	160	36*	12*	110
14214	12	392.55	404	180	36*	12*	115
	14	456.58	468	200	36*	12*	140
	6	284.00	304	80	36	12	90
	8	371.06	390	120	36	12	90
	10	459.52	480	160	36	12	110
	12	548.65	570	200	36	12	115
	6	284.00	304	120	45	15	95
	7	327.31	344	150	45	15	100
14218	8	371.06	390	180	45	15	115
	9	415.18	435	220	45	15	140
	10	459.52	480	220	45	15	140
	11	504.02	524	290	45	15	240
	12	548.64	570	290	45	15	240
	13	593.37	614	350	45	15	300
	14	638.15	660	350	45	15	300
	15	682.87	702	350	45	15	300
14222	16	727.90	748	350	45	15	300
	6	284.00	304	120	60	20	110
	8	371.06	390	180	60	20	110
	10	459.52	480	240	60	20	110
	6	284.00	304	120	60	20	105
	7	327.31	344	150	60	20	110
	8	371.06	390	180	60	20	115
	9	415.18	435	220	60	20	140
14226	10	459.52	480	220	60	20	140
	11	504.02	524	290	60	20	240
	12	548.64	570	290	60	20	240
	13	593.37	614	350	60	20	300
	14	638.15	660	350	60	20	300
	15	682.87	702	350	60	20	300
	16	727.90	748	240	60	20	300
	6	432.80	459	170	65	25	105
21640	7	498.75	525	170	65	25	105
	8	565.48	592	280	65	25	230
	9	632.71	659	350	65	25	300
	10	700.29	726	350	65	25	300
	6	320.00	342	150	65	25	105
16025	8	418.10	440	170	65	25	105
	10	517.77	540	300	65	25	250
	8	522.40	546	280	65	25	230
20028	10	647.40	672	350	65	25	300
	12	772.80	797	350	65	25	300
	8	679.41	709	350	82	32	300
26040	10	841.37	870	400	82	31	340
	12	1004.56	1035	500	82	32	400

John King have standard bolt hole detail. Bolt detail may however vary and it is recommended the buyer consults our technical department for clarification



JOHN KING

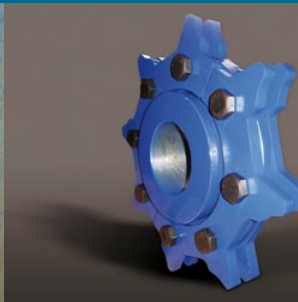

John King Chains Limited

New Climax Works,
Lancaster Business Park,
Sherburn-in-Elmet LS25 6NS UK
Tel: (44) 1977 681 910
Fax: (44) 1977 681 899
Email: general@johnkingchains.co.uk

John King Chains (Central Europe)

ul. Puchacza 5
89-100 Nakło nad Notecią, Poland
Tel: (48) 538 343 991
Mobile: (48) 600 871 077
Email: aw@johnkingchains.com

John King Chains (USA)

Charleston
South Carolina
United States of America
Mobile: (1) 843 998 1767
Email: ow@johnkingchains.com

John King Chains (SA) (PTY) Ltd.

5 Charlie Road, Hughes
Boksburg, 1459, South Africa
Tel: (27) 11 894 3570
Fax: (27) 11 894 3501
Email: sales@jkc.co.za

Cadenas John King Ltda.

Anibal Pinto 1249
Concepción
Chile
Tel: (56) 41 2214948
Email: manuel@johnkingchains.com

John King Chains Ltd.

Rosario, Santa Fe
Argentina
Mobile: (54) 9 341 2 14 92 42
Email: sv@johnkingchains.com



FM 77342
ISO 9001

www.johnkingchains.com