

11a Wing angle Set and sweep



1. Place airframe on old engine box.
2. Slide tail sling under aft fuselage.
3. Place digital level across upper spar box tubes next to center tabs.



4. Note the angle of the top of the spar box.
5. Slide wings into place.
6. Fabricate wing incidence jig as shown in provided drawing.
7. Measure out from the root 18" on each wing .
8. Place jig on left wing.
9. Set wing as Described in Section 11 of the process manual.
10. Hold wing in position.
11. Drill aft angle of incidence hole to 5/16"

11a Wing angle Set and sweep



Material for the jig should be at least 1" thick and of solid wood, do not use ply. Pine works well.

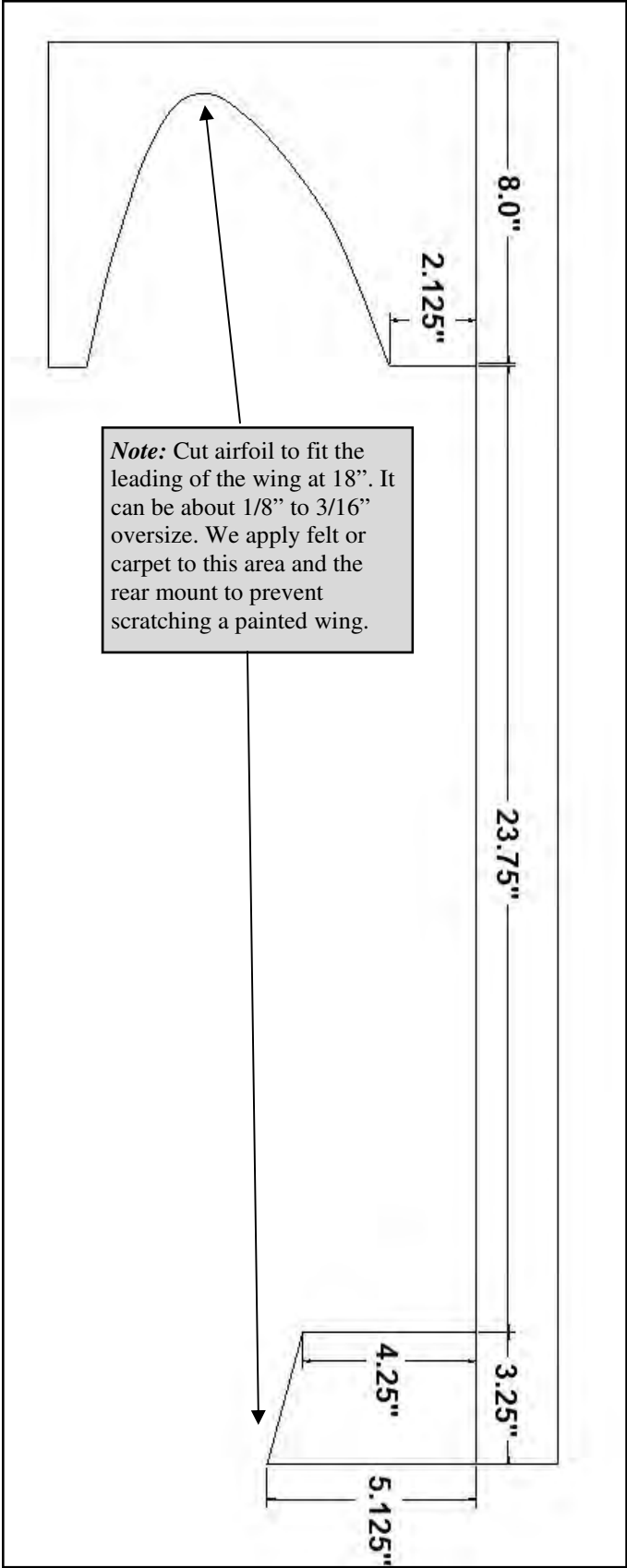

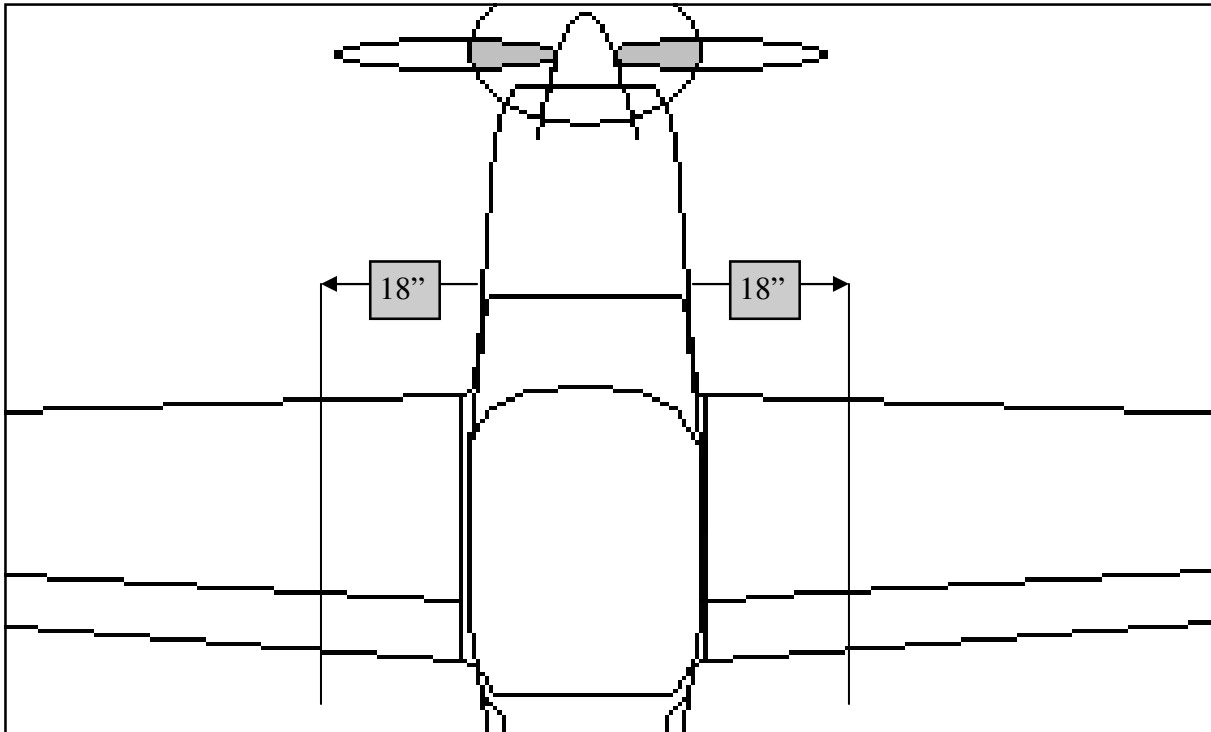

- 12.Re-check incidence.
- 13.Drill forward incidence hole.
- 14.Note the angle of the left wing. The wing depicted in the picture has an angle of 0.7 degrees. The right wing will now be set to match it exactly. Your angle may be different and that is ok. The main point to make each wing match.
- 15.Move jig to right wing and repeat the process.



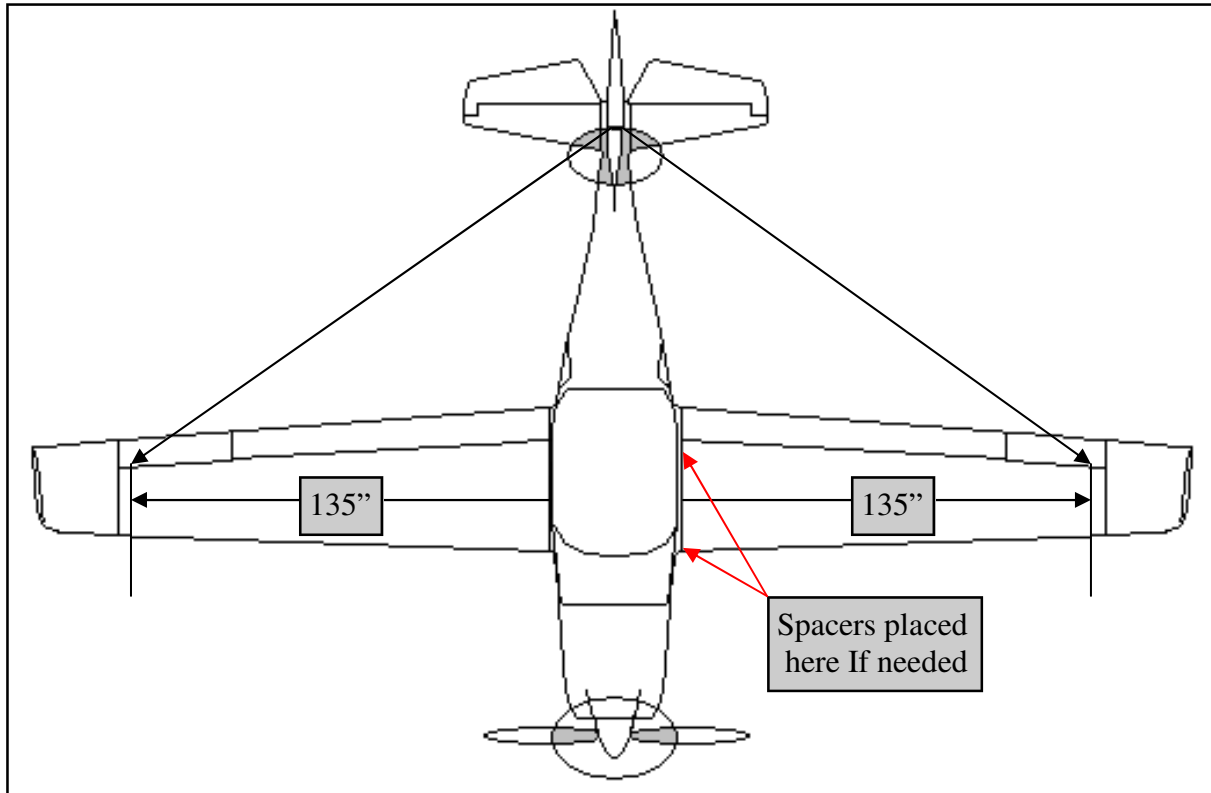

16. Measure out 135" from the fuselage wing root on the trailing edge wing skin. Do not use the end of the wing skin at the trailing edge because the skin could be 1/8" longer than the other side.
17. Next measure from the leading edge of the vertical stab at the top of the tail, to the mark on each wing.
18. Note the measurements. These should be within 1/8" of each other.
19. If they are not don't panic you have not done anything wrong. Since a popcicle stick is the same thickness as a washer you can use those to shim the leading edge or trailing edge roots to achieve exacting measurements.
20. These will be placed at or near the AOI holes since that is where the washers will go.
21. Generally there is 1 washer between the co-pilot side leading edge AOI, no washer in the rear.
22. In general the pilot side leading edge gets no washers and the pilot side trailing edge get 3-4 washers.
23. Once satisfied with the measurements write the number of sticks used at each point on the inside of the fuselage where they go.