

PROPRIETARY AND CONFIDENTIAL
 THE INFORMATION CONTAINED IN THIS DRAWING IS THE SOLE PROPERTY OF VECTOR ELECTRONICS & TECHNOLOGY, INC. ANY REPRODUCTION IN PART OR AS A WHOLE WITHOUT THE WRITTEN PERMISSION OF VECTOR ELECTRONICS & TECHNOLOGY, INC. IS PROHIBITED.

REVISIONS				
ZONE	REV	DESCRIPTION	DATE	APPROVED
ALL	A	INITIAL RELEASE	02/27/15	
ALL	B	ADDED P/N: 9010002 FOR RTM PANELS	09/19/17	
ALL	C	ADDED NOTE FOR OPTIONAL CENTER L-BRACKET	05/23/19	
ALL	D	UPDATED PARTS LIST FOR P/N: 9010002 -1	12/04/23	

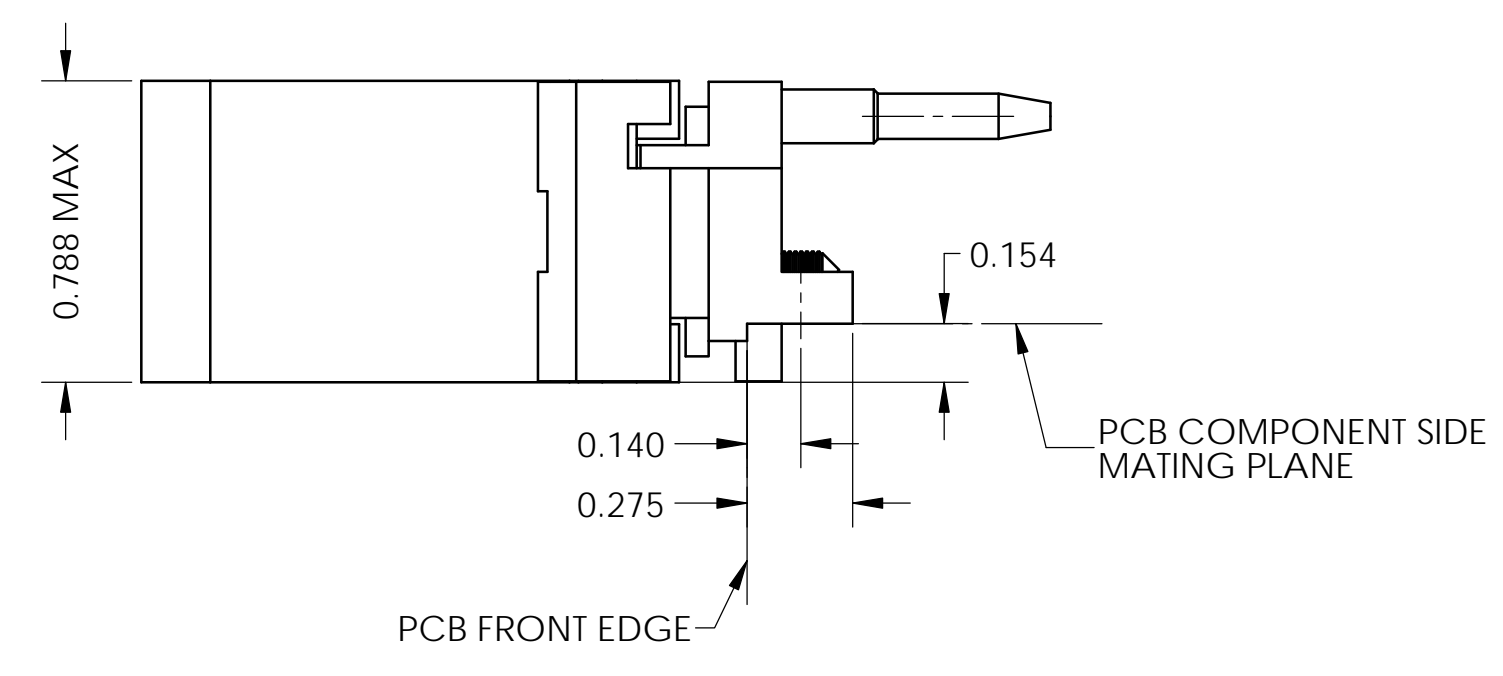

TOP HANDLE DETAIL

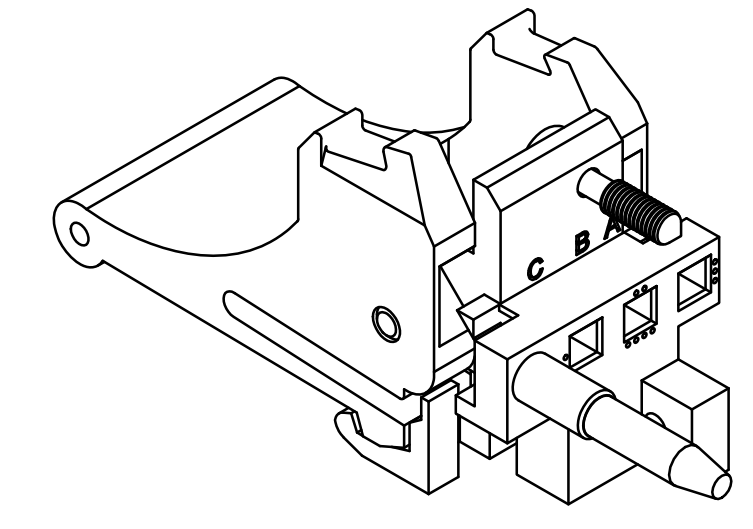
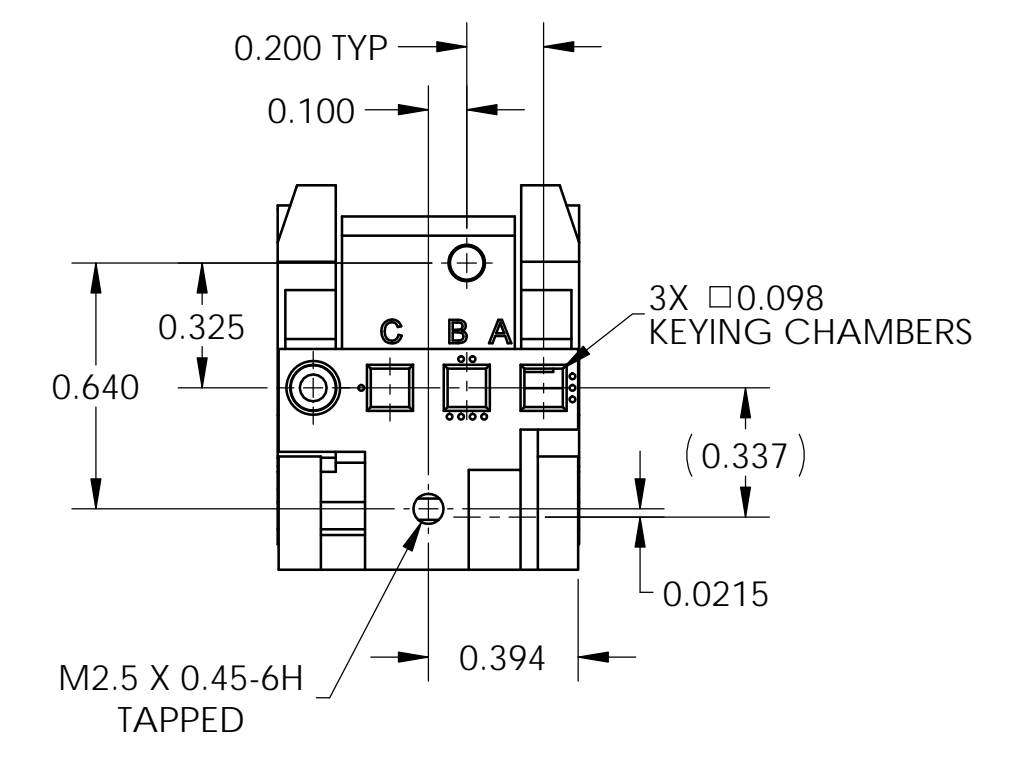
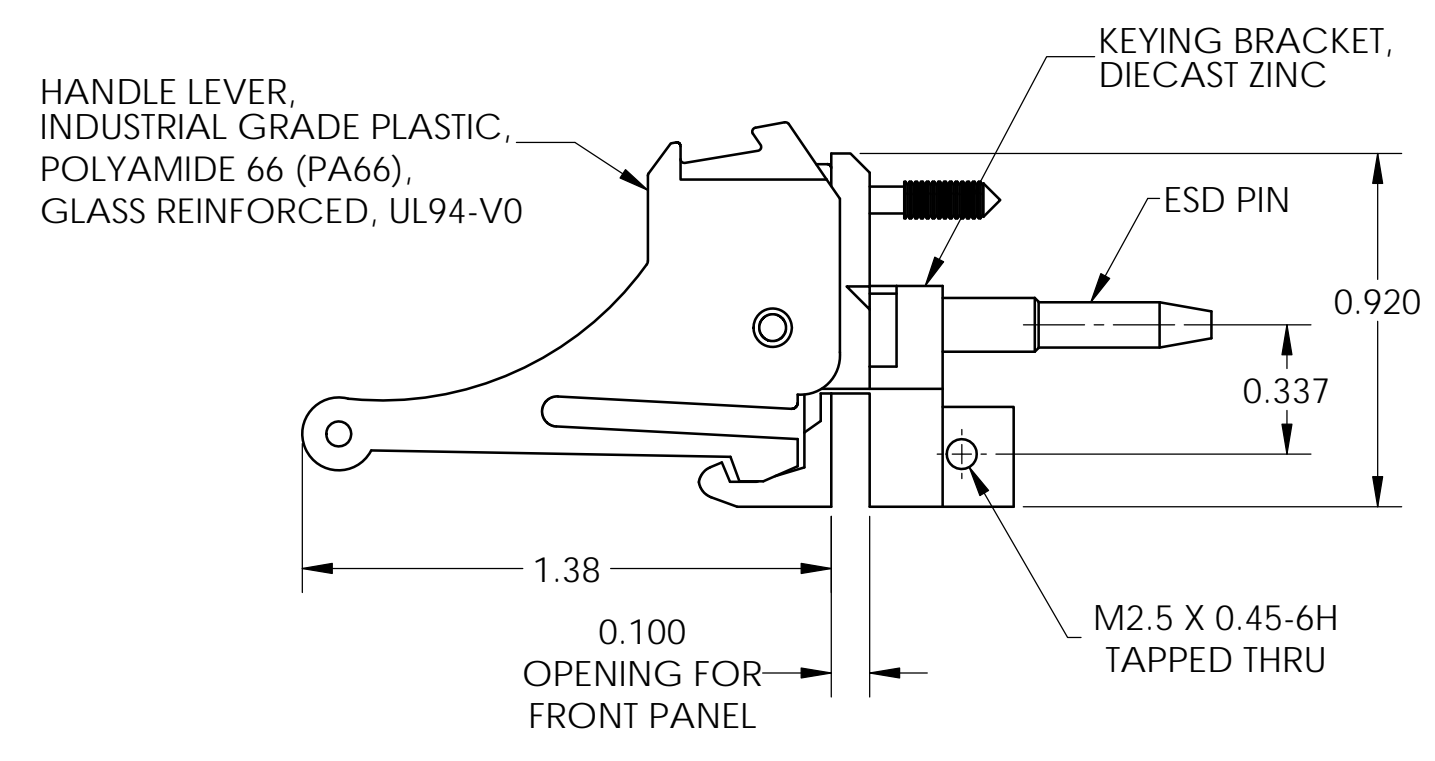
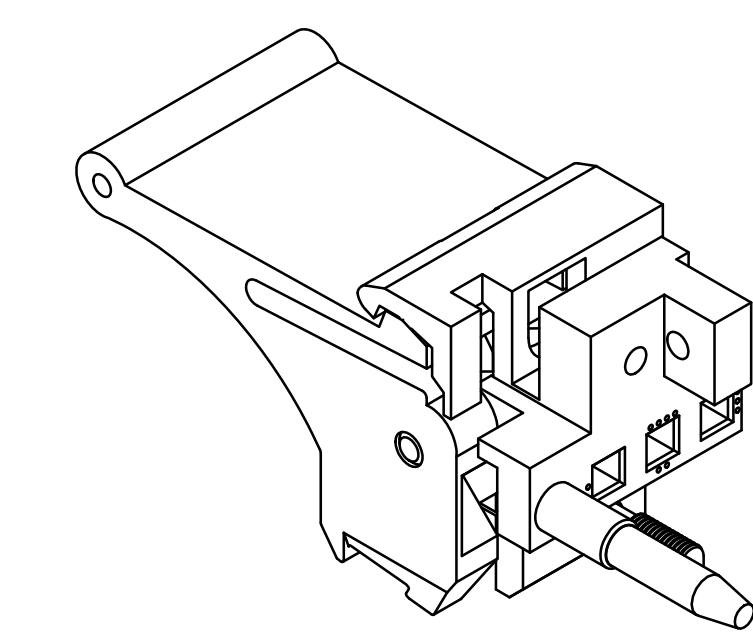
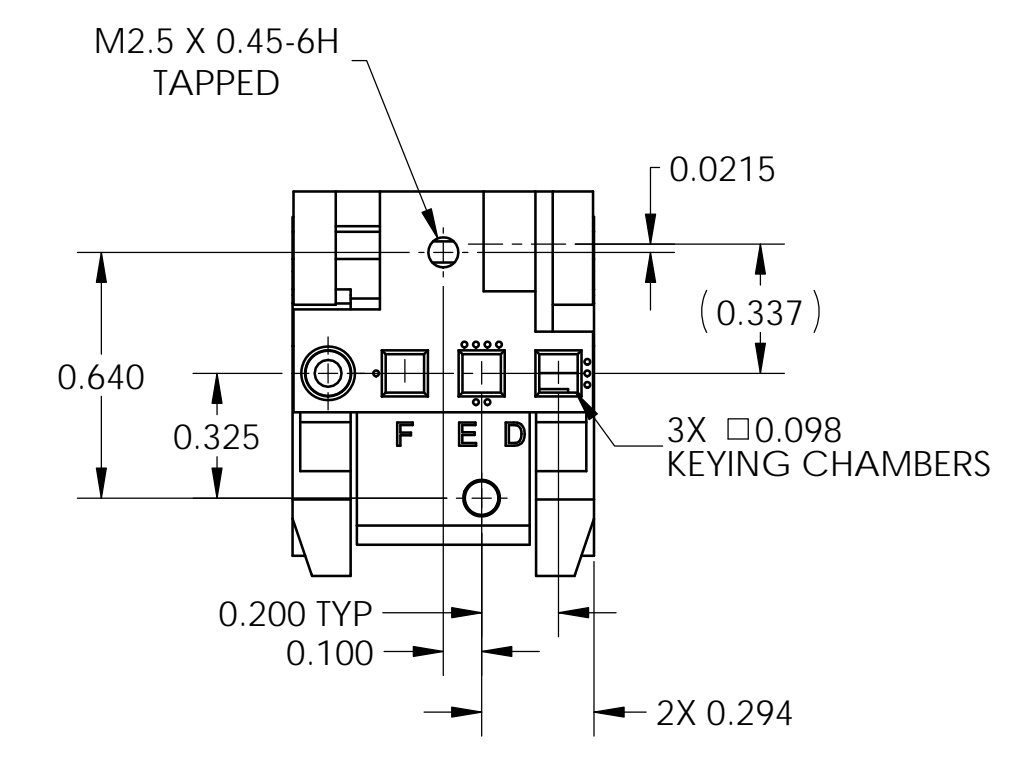
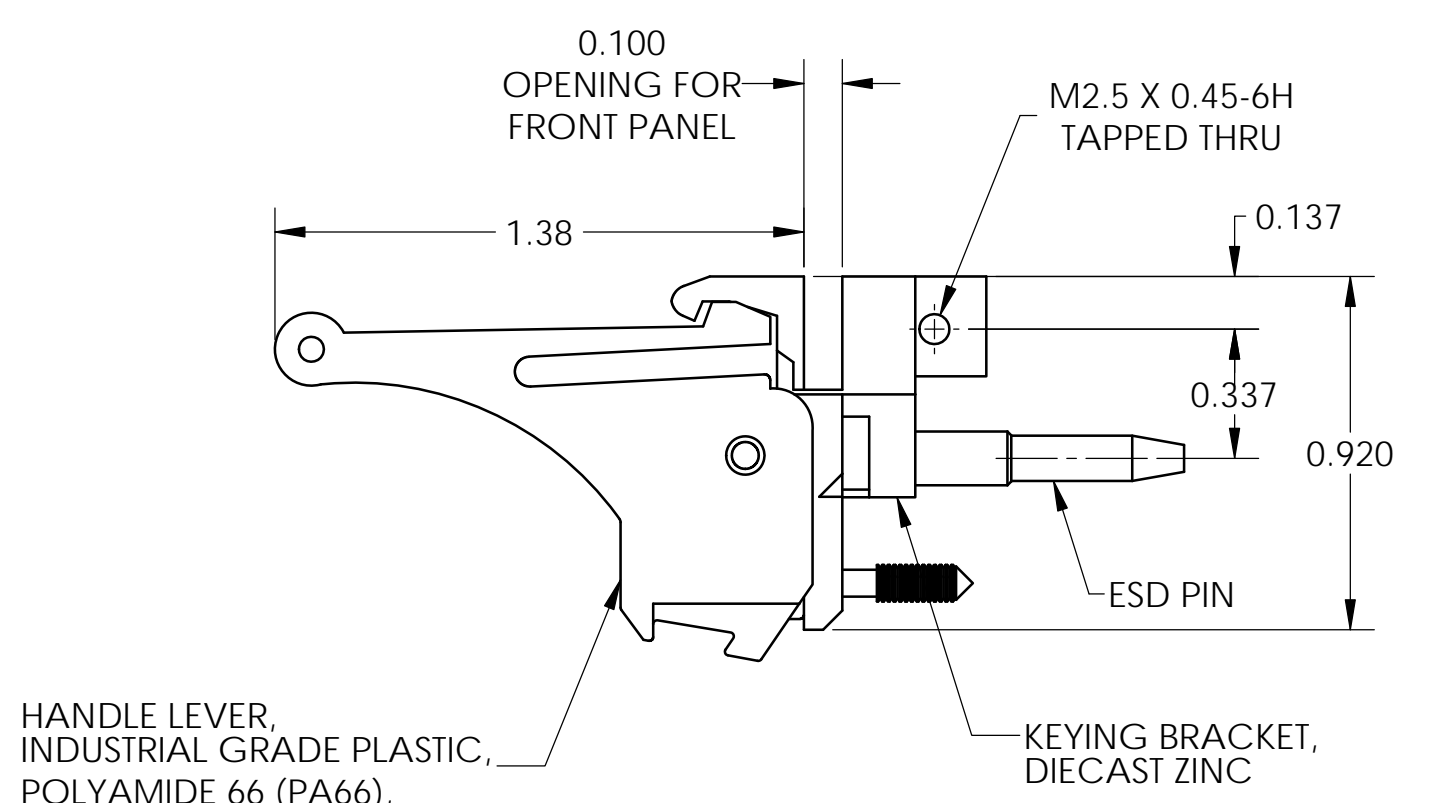
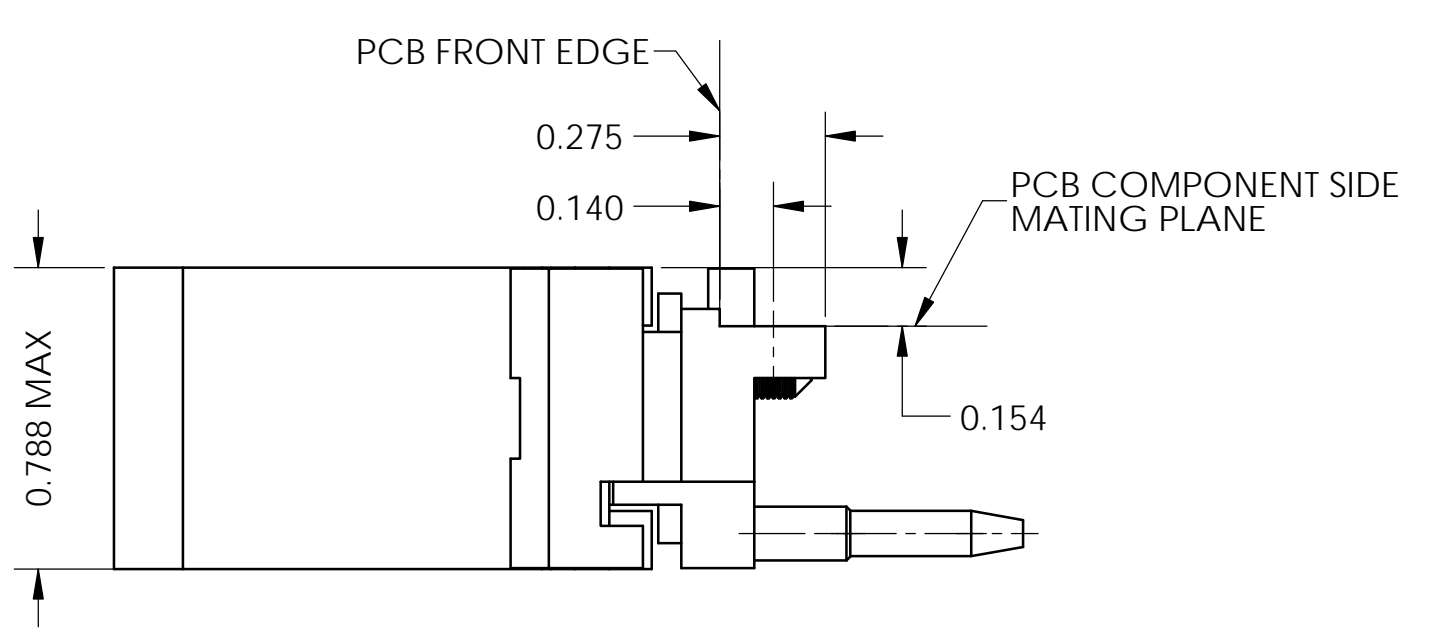

BOTTOM HANDLE DETAIL

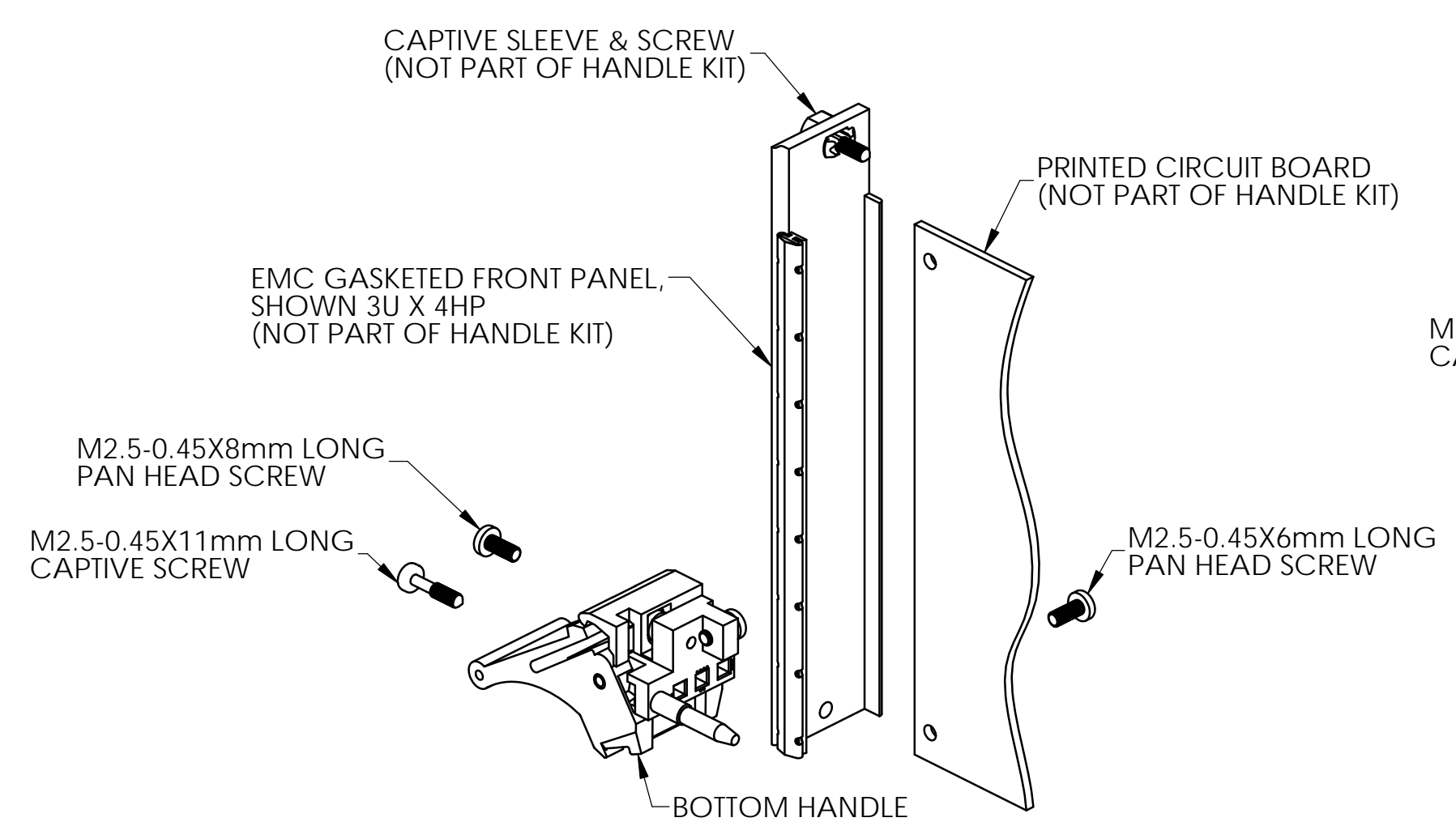
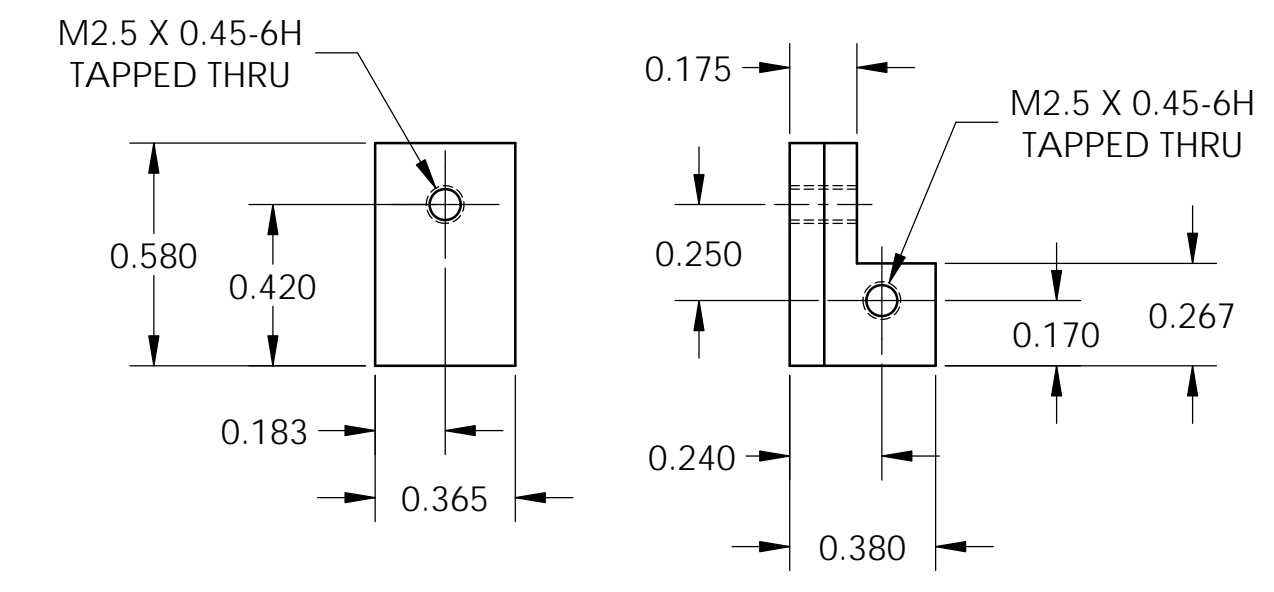
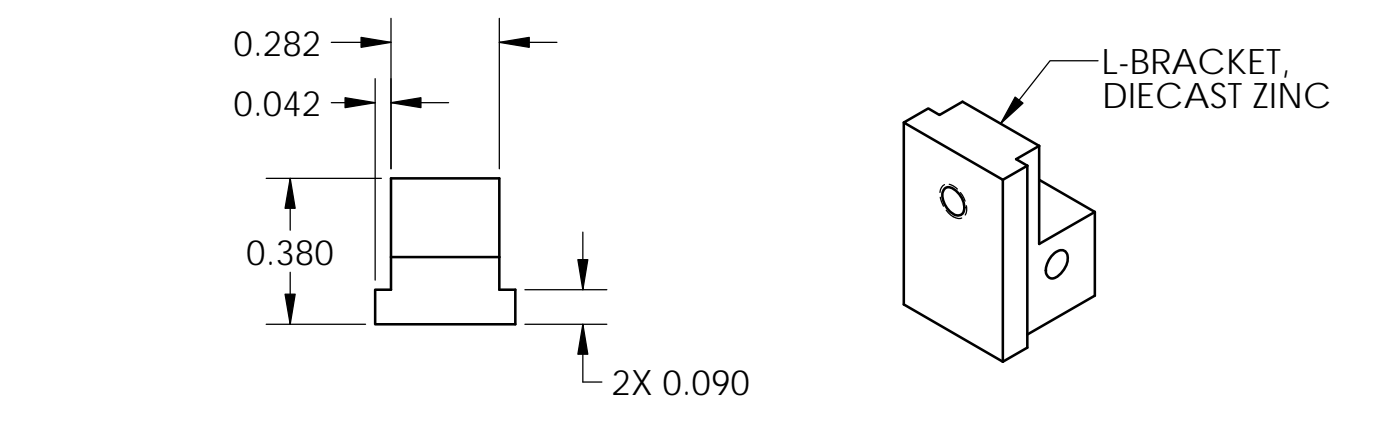

EXPLODED VIEW 3U FRONT PLUG-IN CARD ASSEMBLY

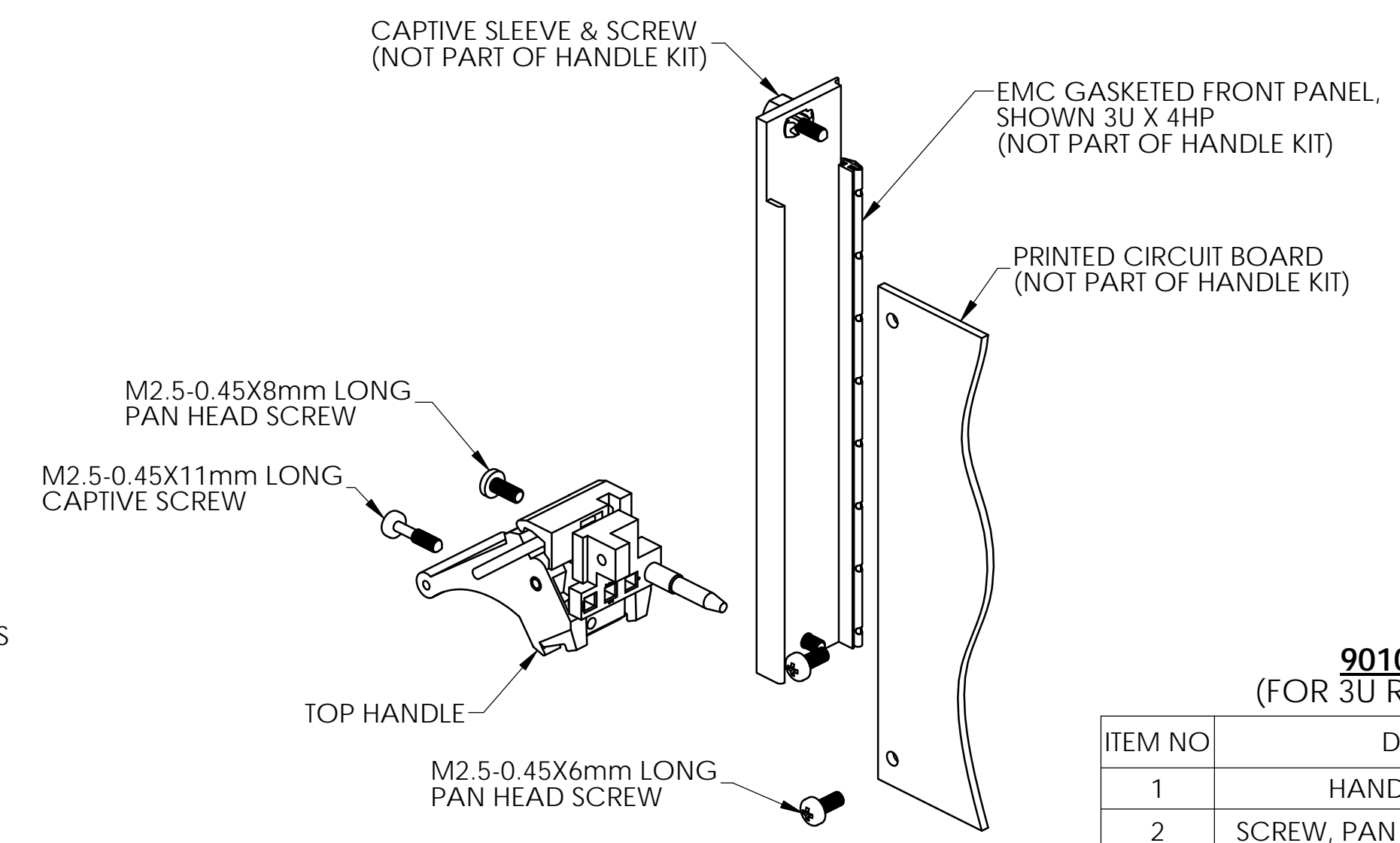

EXPLODED VIEW 3U RTM PLUG-IN CARD ASSEMBLY

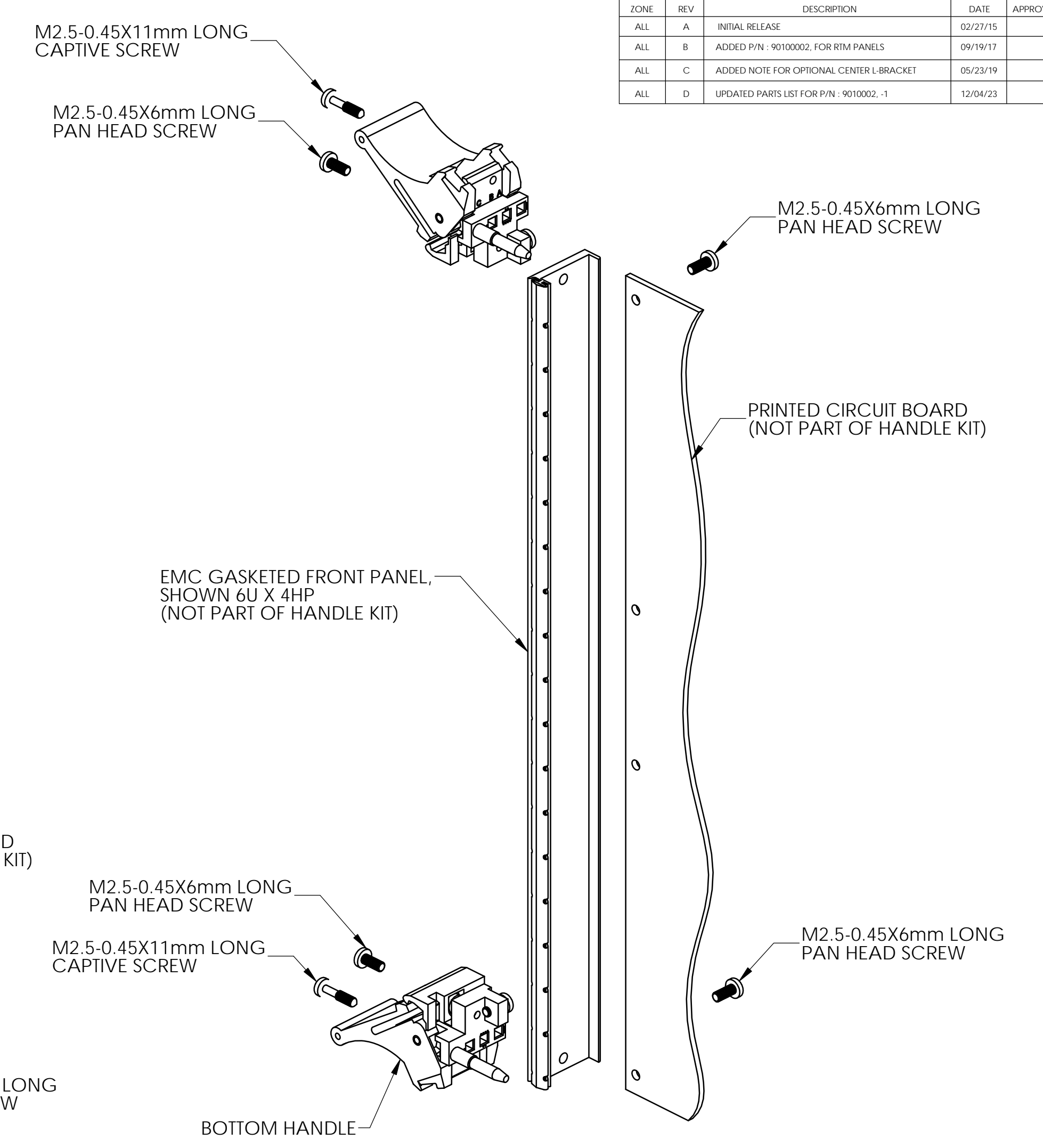

EXPLODED VIEW 6U OR 9U PLUG-IN CARD ASSEMBLY

90100016 PARTS LIST (FOR 6U OR 9U FRONT PANEL ASSEMBLY)

ITEM NO	DESCRIPTION	QTY	U/M
1	HANDLE, BOTTOM, TYPE IV	1	EACH
2	HANDLE, TOP, TYPE IV	1	EACH
3	L-BRACKET, METAL (OPTIONAL)	1	EACH
4	SCREW, PAN HEAD, M2.5-0.45X6mm	5	EACH
5	SCREW, CAPTIVE, M2.5-0.45X11mm	2	EACH
6	SCREW, FLAT HEAD, M2.5-0.45X8mm	1	EACH

90100002-1 PARTS LIST (FOR 3U FRONT PANEL ASSEMBLY)

ITEM NO	DESCRIPTION	QTY	U/M
1	HANDLE, BOTTOM, TYPE IV	1	EACH
2	SCREW, PAN HEAD, M2.5-0.45X6mm	1	EACH
3	SCREW, PAN HEAD, M2.5-0.45X8mm	1	EACH
4	SCREW, CAPTIVE, M2.5-0.45X11mm	1	EACH

90100002 PARTS LIST (FOR 3U RTM PANEL ASSEMBLY)

ITEM NO	DESCRIPTION	QTY	U/M
1	HANDLE, TOP, TYPE IV	1	EACH
2	SCREW, PAN HEAD, M2.5-0.45X6mm	1	EACH
3	SCREW, PAN HEAD, M2.5-0.45X8mm	1	EACH
4	SCREW, CAPTIVE, M2.5-0.45X11mm	1	EACH

UNLESS OTHERWISE SPECIFIED: DIMENSIONS ARE IN INCHES

TOLERANCES: DEC .XX ±0.1, DEC .XXX ±0.03, DEC .XXXX ±0.010, FRACTIONS ±0.050, ANGLES ±1°

THIRD ANGLE PROJECTION

MATERIAL: FINISH

NAME: TRISHAR

DATE: 08/31/12

VECTOR ELECTRONICS & TECHNOLOGY, INC. 81115 VANOWEN ST., NORTH HOLLYWOOD, CA 91368

INJECTOR/EJECTOR HANDLE, TYPE IV 1101.10

SIZE: **D**

DWG. NO.: **IEL-TYPE-IV**

REV: **D**

SCALE: 1:1 | CAGE CODE: 82893 | SHEET 1 OF 1