

How to Install Super-Screw 63 to 200

Note: For clarity, areas with screws installed are shown in orange in the steps below.

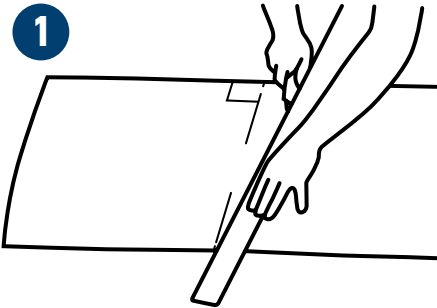

Install the Super-Screw on a bias.

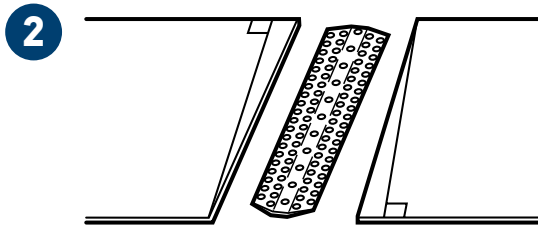

Square the belt your normal way. Then drop down on either side 1" per 12" of the belt width. On the other side of the belt do the reverse so the belt ends will mate/match. NOTE: Matching the belt ends will ensure that there is NO GAP between the ends when installing the final screws in STEP 6.

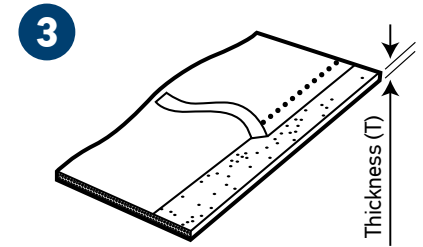

Skive the top of the belt to the appropriate depth. (Required when running wipers, cleaners or scrapers.)

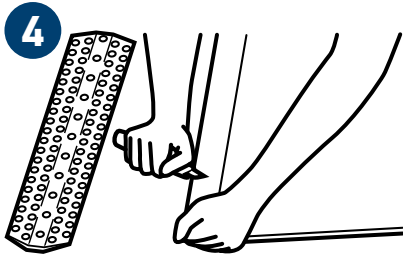

4A
Slightly chamfer or sharpen the top and bottom of both ends of your belt to aid in sliding the ends of the belt into the Super-Screw.

4B
Position the Super-Screw so that the belt is firm against the preinserted spacers.

Choose Super-Screw (SS) based on belt thickness (T)			
Thickness (T)	SS-63	SS 65-80	SS 85-100
3-4 mm	5 x 10	5 x 12	
5-6 mm	5 x 12	5 x 14	5 x 16
7-8 mm	5 x 14	5 x 16	5 x 18
9-10 mm	5 x 16	5 x 18	5 x 20
11-12 mm	5 x 18	5 x 20	5 x 22
13-14 mm	Trim down	Trim down	5 x 24

5 Screwing Sequence

USE A HEAVY DUTY 18VOLT OR GREATER DRILL

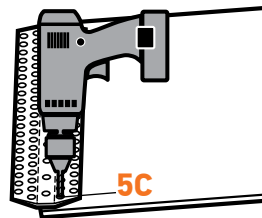
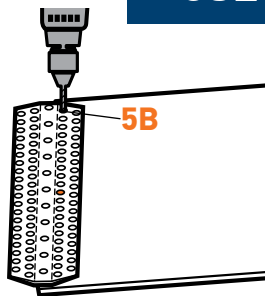
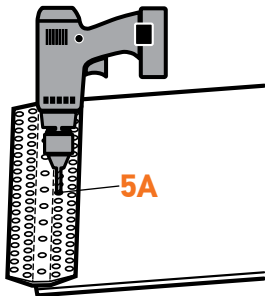

Install one screw in the center of the fastener (step 5A), in the row closest to the spacers.

Then install a screw in both edges of the fastener (step 5B), (step 5C), then in the center between the center screw and the edge screw. Keep centering between the last screws installed (step 5D), skipping from one side of the fastener to the other, and complete the row in this fashion.

Tighten the screws until the fastener slightly puckers, this will indicate that the nut on the back side of the fastener has been seated in the carcass of the belt.

Completely install second row of screws (step 5E), exactly like the first row. Install the center screw first again, the edge screws second (step 5F) and then the centers until the row is complete.

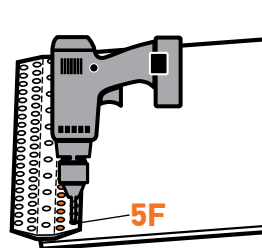
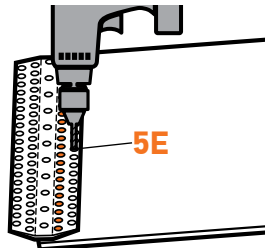
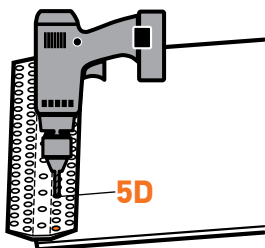

VERY IMPORTANT!
Spacers must be removed!



REMOVE spacers across the center of the fastener, discard the spacers. Save the screws. (This will be the last row of screws installed.)

VERY IMPORTANT!
Belt ends must meet firmly beneath the top-cover of the Super-Screw!

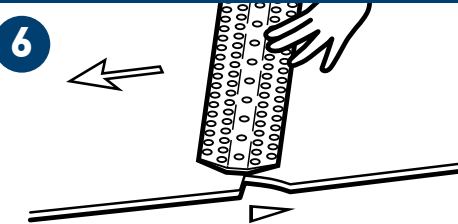

Butt both ends of the belt together for a tight fit. Next, follow the screwing sequence stated above, installing the center row last.

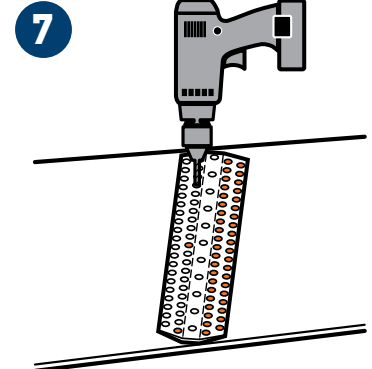

Check the bottom of the fastener making sure the nuts are pulled in the carcass of the belt.

**PLEASE UNFOLD TO READ
IMPORTANT INSTALLATION
INSTRUCTIONS.**

**REMINDER: BE SURE TO REMOVE
SPACERS -AND- BUTT BOTH ENDS
OF THE BELT TOGETHER BEFORE
INSTALLING THE FINAL SCREWS.**



MLT
Minet Lacing Technology

SUPER-SCREW®
Instruction
Sheet
Original
1998

Fastener Size _____

Screw Size _____ mm **Qty** _____

Hot Oil MSHA

Stainless Steel Slider Back

Grade 1 Abrasion Resistant