

STORAGE ACCESS CONTROL SOLUTIONS FOR ANY FACILITY

SCHOOL DISTRICTS | UNIVERSITIES | CORPORATE CAMPUSES | INDUSTRIAL SITES | HOSPITALS
DISTRIBUTION CENTERS | WORSHIP CENTERS | CALL CENTERS | GOVERNMENT FACILITIES

**NEW BUILD
RETRO FIT
UPGRADE**



Monitor Dynamics' Access Control allows for diverse applications for secured storage solutions. Smart Locker Systems provide a contact-less, fully integrated and secure system to simplify credentialed access, storage, product pickup/drop-off and retrieval, ensuring authorized access only with recorded monitoring.



Any type of facility may implement smart storage with the latest security technology.

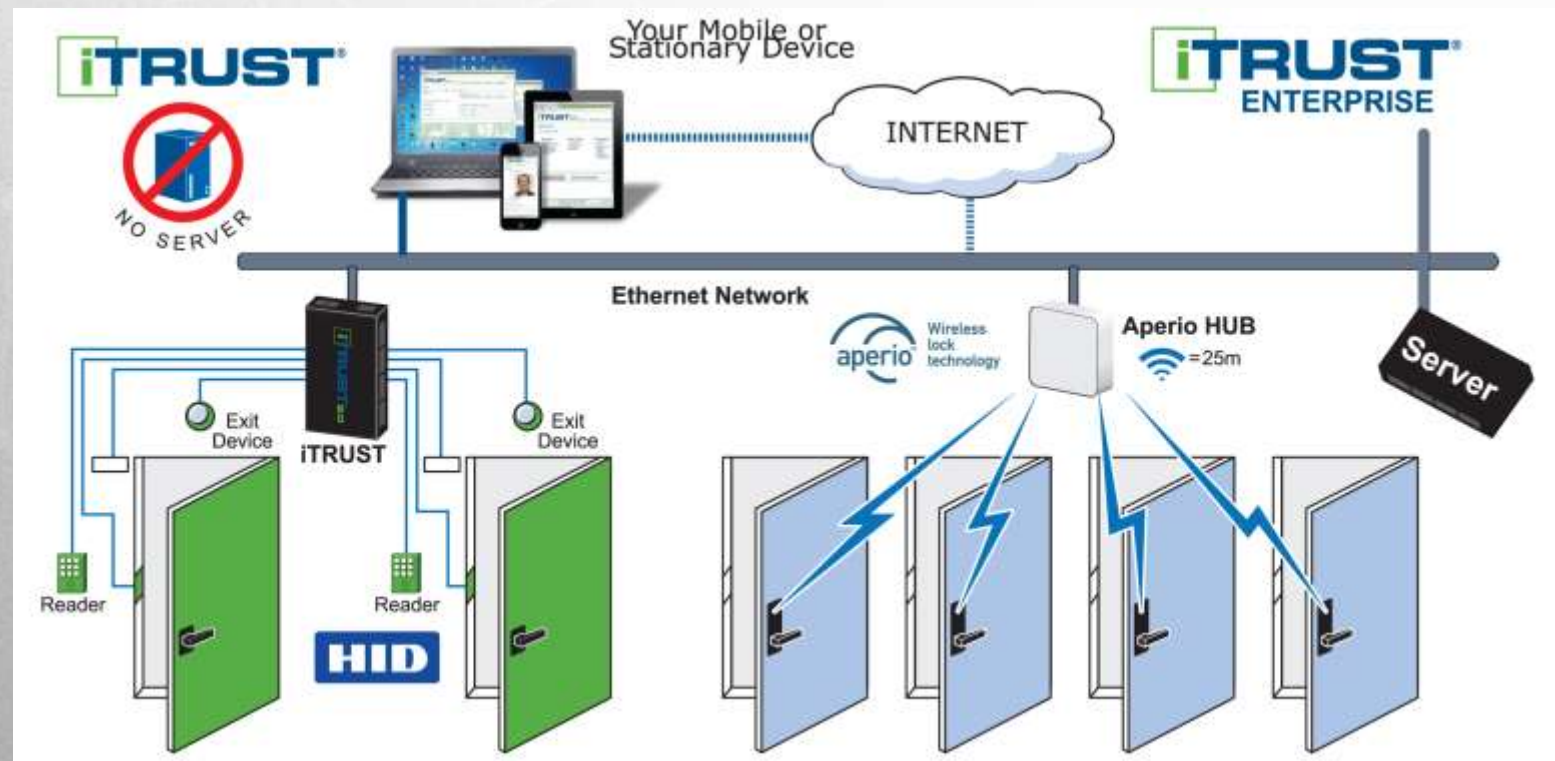

iTRUST access control technology which may be implemented by itself or in conjunction with most access control systems. Credentials are assigned at the time of card enrollment ensuring authorized access control is in place for designated storage lockers and points of entry.

The complete line of Aperio Wireless Locks are compatible.

HES KS100
Server Cabinet Lock
for data security



SARGENT IN100
Lock for wood and
metal doors



ADAMS RITE G100
Digital glass door lock for
interior entryways



HES K100
Cabinet Lock for
Smart Storage Systems



SECURITRON R100
Card Reader for
employee and visitor

Smart Locker Systems offers custom solutions for all facility storage needs while ensuring the strictest security standards are implemented.

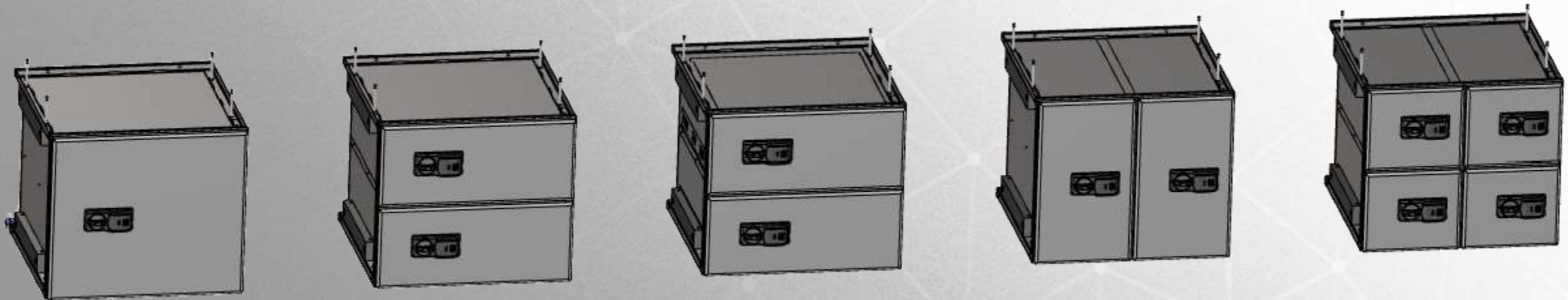



















Periodic Table of the Elements

1	2		3	4	5	6	7	8	9	10	11	12	13	14	15	16	17	18	19	20		21	22	23	24	25	26	27	28	29	30	31	32	33	34	35	36		37	38	39	40		41	42	43	44	45	46	47	48	49	50	51	52	53	54	55	56	57	58	59	60	61	62	63	64	65	66	67	68	69	70	71	72	73	74	75	76	77	78	79	80		81	82	83	84	85	86	87	88	89	90		91	92	93	94	95	96	97	98	99	100
---	---	--	---	---	---	---	---	---	---	----	----	----	----	----	----	----	----	----	----	----	--	----	----	----	----	----	----	----	----	----	----	----	----	----	----	----	----	--	----	----	----	----	--	----	----	----	----	----	----	----	----	----	----	----	----	----	----	----	----	----	----	----	----	----	----	----	----	----	----	----	----	----	----	----	----	----	----	----	----	----	----	----	----	--	----	----	----	----	----	----	----	----	----	----	--	----	----	----	----	----	----	----	----	----	-----









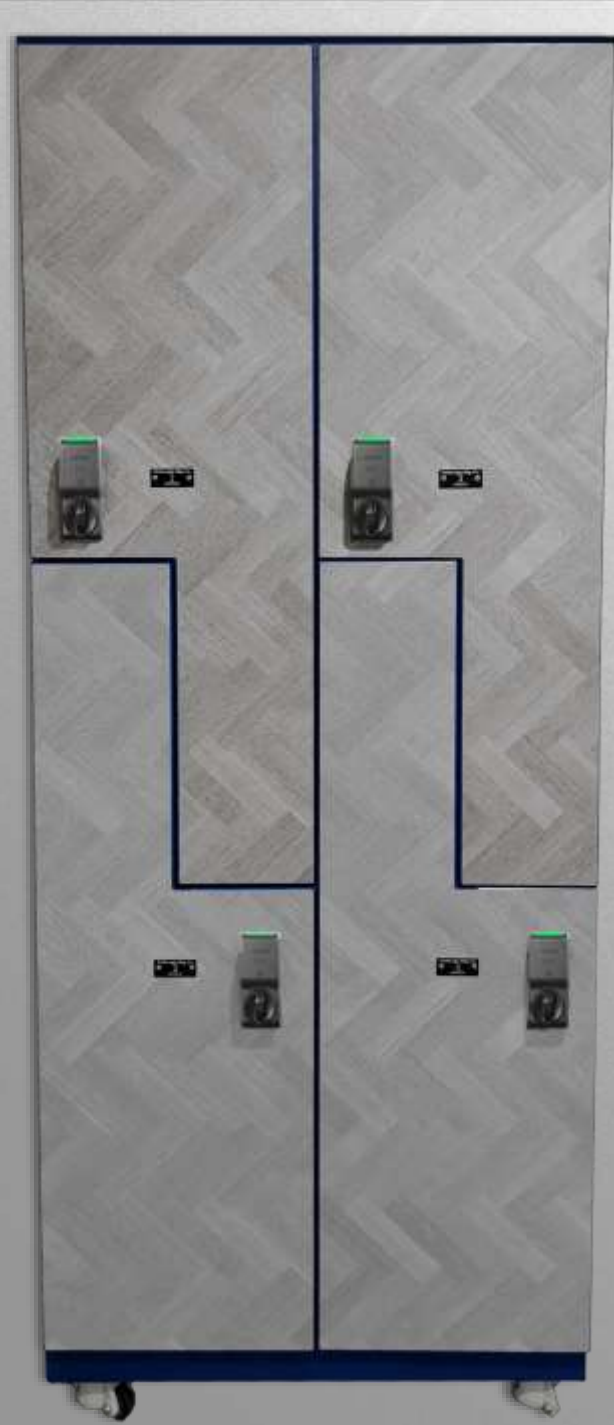



lockers . cabinets . furniture



[Create Cardholder](#)

[Import Cardholders](#)

Cardholders

Name	ID Number	Photo	Active
Dallon			Active
Greg Hackney	admin		Active
Hayden			Active
Kade			Active
Mitchell			Active
Wes	admin		Active

Access Level

Name Lockers - Freshman Wing

Doors

Door

Schedule

Created by Troy

Created time 01/14/2020 11:27:18

Modified by Troy

Modified time 01/14/2020 11:27:18



Events

Description	Device	Cardholder	Time	Info
Successful Sign In	iTRUST	Troy	01/14/2020 13:51:11	
Door Mode: Card Only	Main Entrance		01/14/2020 13:36:12	
Door Mode: Unlocked	Main Entrance		01/14/2020 13:36:08	
Successful Sign In	iTRUST	Troy	01/14/2020 13:35:39	

AVAILABLE

OCCUPIED

1ST LOCKER ROW



2ND LOCKER ROW



3RD LOCKER ROW

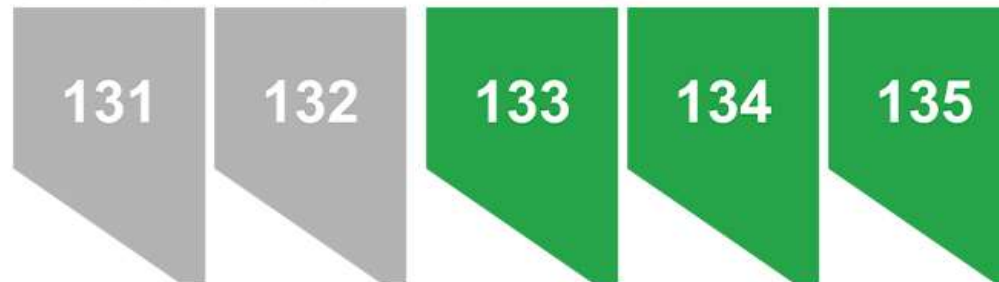

How to Get a Locker:

1. Find a locker on the screen that is available.
2. Present your EY badge to that lock and turn the knob to open when the light flashes green.
3. Put your belongings inside and close the door.
4. To get your belongings out of the locker repeat step two.

Note: Always make sure that the locker shows as occupied if your belongings are in that locker.

AVAILABLE

OCCUPIED

1ST LOCKER ROW

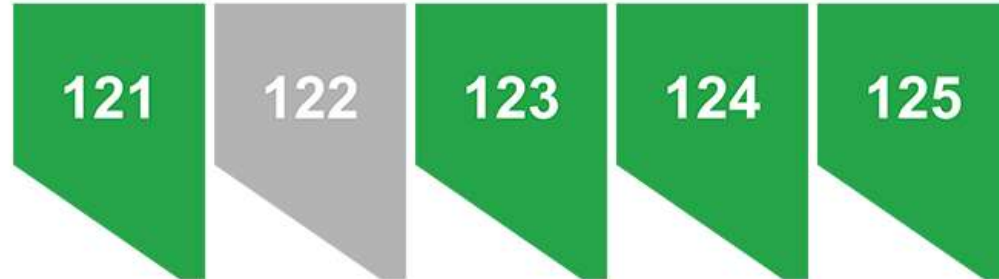

2ND LOCKER ROW

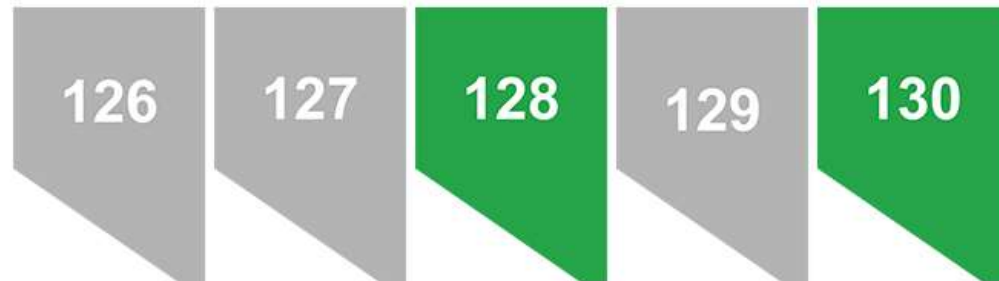

3RD LOCKER ROW

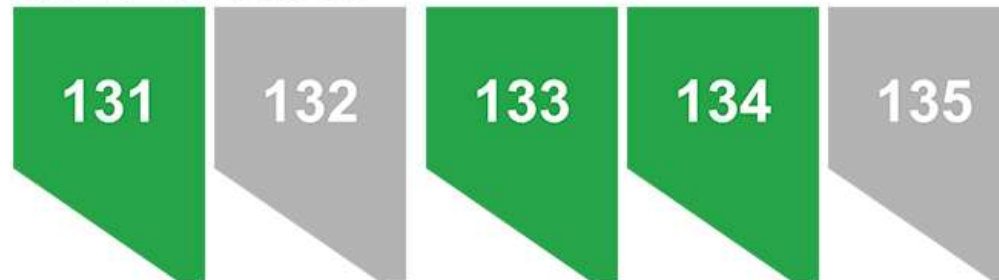

How to Get a Locker:

1. Find a locker on the screen that is available.
2. Present your EY badge to that lock and turn the knob to open when the light flashes green.
3. Put your belongings inside and close the door.
4. To get your belongings out of the locker repeat step two.

Note: Always make sure that the locker shows as occupied if your belongings are in that locker.

AVAILABLE

OCCUPIED

1ST LOCKER ROW



2ND LOCKER ROW



3RD LOCKER ROW

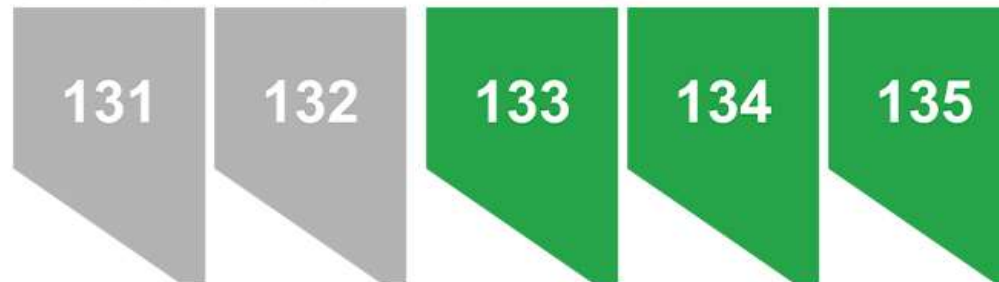

How to Get a Locker:

1. Find a locker on the screen that is available.
2. Present your EY badge to that lock and turn the knob to open when the light flashes green.
3. Put your belongings inside and close the door.
4. To get your belongings out of the locker repeat step two.

Note: Always make sure that the locker shows as occupied if your belongings are in that locker.