



MIAMI FILTER

MANUFACTURER OF WATER TREATMENT SYSTEMS

INSTRUCTION MANUAL

AUTOMATIC CONTROL

VCOM SERIES



NATIONAL
SANITATION
FOUNDATION



UNDER WRITER
LABORATORIES

7384 Commercial Circle, Fort Pierce, FL 34951
Ph 772-466-1440 Toll Free 888-642-6482 Fax 772-466-0364
www.miamifilter.com

INDEX

	Page
RECEIVING INSPECTION.....	3
WARNING – LIFTING LUG.....	4
FILTER ROOM LAYOUT DIAGRAM.....	5
TANK INSTALLATION.....	6
SIGHT GLASS.....	11
ADDING MEDIA.....	12
OPERATING INSTRUCTIONS – VCOM SERIES	13
DRAIN AND WINTERIZING PORTS.....	18
SACRIFICIAL ANODE.....	19
EMERGENCY RELIEF VALVES.....	20
FINAL PAINTING.....	21
TROUBLESHOOTING GUIDE.....	22
LIMITED WARRANTY.....	25
DAILY LOG.....	26
PACKING LIST.....	27

RECEIVING INSPECTION

The material in this shipment was factory inspected prior to shipment and was fabricated in accordance with approved drawings and/or information furnished to us.

Our responsibility for the shipment terminated when we turned it over to the freight carrier. So to protect your interest, we suggest that you check the shipment promptly upon arrival.

- **DAMAGE CLEARLY VISIBLE:** If the shipment is obviously damaged upon arrival, please have the freight agent indicate such damage immediately on both the receipt and on the freight bill.
- **DAMAGE NOT INITIALLY APPARENT:** If the shipment is received in apparent good condition, but after opening the crates or boxes the contents are found to be damaged, call the freight agent or adjuster promptly to view the same. If possible, take pictures of the damaged contents. Have the freight agent make a notation of such previously unnoticed damage on the freight bill.
- **FIELD REPAIR OF DAMAGE:** Do not attempt field repairs to damaged equipment. Contact us for corrective action. Failure to inform MIAMI FILTER, INC. may deem all warranties null and void.
- **CLAIMS FOR DAMAGE (TO FREIGHT CARRIER):** Make your claims promptly as many carriers will not accept claims after a reasonable length of time. MIAMI FILTER, LLC is willing to assist you in any way to collect claims for damage or loss. However, we do not assume any responsibility for the collection. As we cannot guarantee delivery, any claim account for loss or damage is not deductible from MIAMI FILTER, INC. invoices. Therefore, all invoices are payable even during the claim adjustment period.
- **SHORTAGE OR DISCREPANCY:** All boxes and bags should be promptly opened and inspected upon arrival. If the contents received do not correspond with quantities indicated on the Freight Bill and/or Bill of Lading, or any other discrepancies are found, contact MIAMI FILTER, INC. promptly.
- **CLAIMS FOR SHORTAGE OR DISCREPANCY (TO MIAMI FILTER):** All claims must be made within 30 days after receipt of shipment. Charge backs are not authorized without prior approval from MIAMI FILTER, INC.. Should our records indicate that a claim is valid, we will advise you of corrective actions or arrange to make the necessary repairs. If our personnel perform a Field Inspection and it is found that it was not a factory error, the cost of the Field Inspection will be charged to you.

Your cooperation in the above procedures is needed and appreciated.

Thank you for choosing MIAMI FILTER, INC.!

WARNING – LIFTING LUG

On the top head of each VCOM-series filter vessel are two (2) Lifting Lugs. These lugs were

designed and installed to lift the filter vessel ONLY when it is in new condition and when it is completely empty. These Lifting Lugs were not designed to support a filter vessel when it is loaded with sand or water.

Failure to follow the above instructions could result in Lifting Lug failure and may result in serious personal injury, property damage, or fatalities.

When moving a loaded filter vessel, a professional crane operator should be consulted.

NEVER use the Lifting Lugs when attempting to move a loaded filter vessel.

ALWAYS REMEMBER – SAFETY FIRST!

TYPICAL FILTER ROOM LAYOUT FOR
HI-RATE PRESSURE MEDIA FILTER

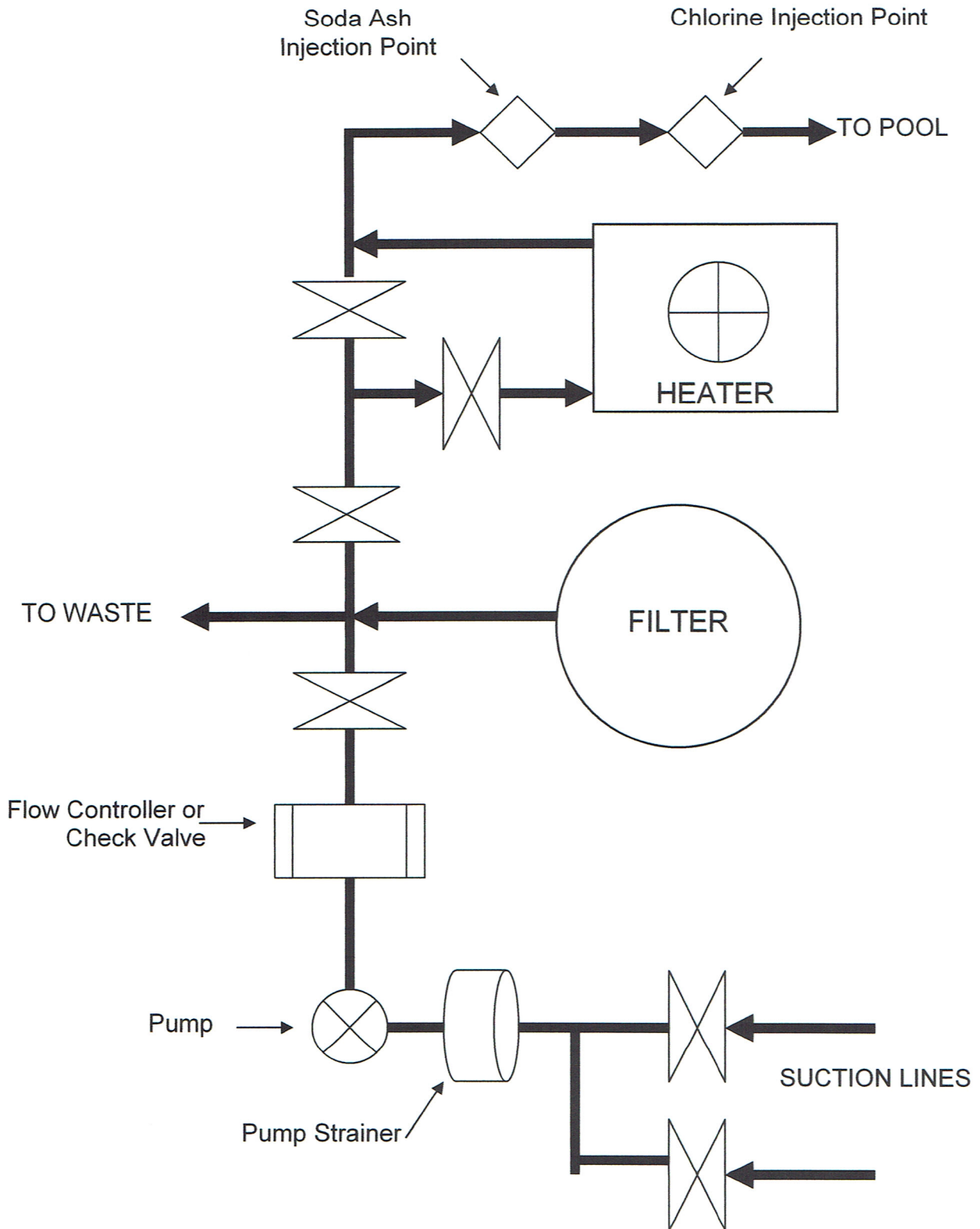

TANK INSTALLATION

All filtration systems including single, dual and triple systems are normally shipped without the face piping installed. It is recommended that the filter tank(s) be installed in the permanent operation position *before* installing the face piping. Standard filter tanks are equipped with non-adjustable strap or structural legs. Adjustable jacklegs are available as a factory option.

Before installing the filtration system, be certain the slab is designed and engineered to support the entire weight (with sand media and water) on the leg support areas. The face piping should be installed only after the filter(s) is in its permanent position(s). The correct amount of bolts and gaskets to mount the face piping are supplied in the accessory box. All system face piping should be installed with the backwash sight glass (pre-taped) located as close as possible to the top tee fitting. See installation on page 11.

On single lever units, the linkage is designed to be installed on the right hand side of the manifold (left side installation available upon request). On dual units, be certain the tanks are level and aligned before installing the face piping. Failure to do so could result in face piping stress cracking due to misalignment and excessive torque. On standard face piping the plumbing connections are as follows:

1. Top Flange = Waste Line (backwash)
2. Center Flange = Influent (from pump)
3. Bottom Flange = Effluent (return to pool or process)

When installing face piping to the filter tank, use the torque sequence shown below to avoid cracking the flanges.

Flange Size	Recommended Torque (Ft-lbs)	Flange Size	Bolt Holes	Bolt Diameter	Bolt Length (min.)	The following tightening sequence is suggested for the flange bolts.
1/2 - 1 1/2	10 – 15 Ft-lbs	1/2	4	1/2	2	<p>CAUTION: UNNECESSARY OVER-TORQUE WILL DAMAGE THE FLANGE</p> <p>A neoprene full-face gasket, 1/8" thick is recommended. More resistant gasket materials should be used in systems handling highly aggressive chemicals.</p>
2 – 4	20 – 30 Ft-lbs	3/4	4	1/2	2	
6 – 8	33 – 50 Ft-lbs	1	4	1/2	2 1/4	
10	53 – 75 Ft-lbs	1 1/4	4	1/2	2 1/4	
12	80 – 110 Ft-lbs	1 1/2	4	1/2	2 1/4	
12-24	110 Ft-lbs	2	4	5/8	3	
Bolts and Gaskets are not furnished. Actual field conditions may require a variation in these recommendations. If higher torque is used, extra care is required to prevent damage to the plastic components. These torques are based on the use of two flat washers and a 1/8" thick full-face neoprene gasket.		2 1/2	4	5/8	3 1/4	
		3	4	5/8	3 1/4	
		4	8	5/8	3 1/2	
		5	8	3/4	3 3/4	
		6	8	3/4	4	
		8	8	3/4	4 1/2	
		10	12	7/8	5	
		12	12	7/8	5	
		14	12	1	5	
		16	16	1	5	
	18	16	1-1/8	5		
	20	20	1-1/8	6		
	24	20	1 1/4	8		
Based on use of two standard flat washers, standard nut and a 1/8" thick gasket.						

TANK INSTALLATION (cont'd)

After placing tank(s) and installing face piping, the following accessories should now be installed.

1. **SINGLE LEVER CONTROL:** If the single lever control was ordered as an option, the control handle should now be installed. The control handle was removed and strapped to the linkage to avoid damage during shipment. To install control handle, remove the two 3/8" x 3" shoulder bolts from the control clevis (mounted on third valve from top). Insert control handle into clevis until all pre-drilled holes in linkages, clevis and control handle are aligned. Before replacing shoulder bolts and tightening the linkages, the smooth shoulders of bolts must be coated with graphite grease or equivalent to protect surfaces during movement. For further information, see single lever control illustration in the manual.
2. **VALVES (Automatic air relief valve and emergency high pressure relief valve):** All necessary fittings are supplied to install both valves. Both valves are to be installed on 3/4" F.I.P. coupling welded in the center of the top head using supplied tees and bushings. See illustration below for proper installation positions. The automatic air relief valve will automatically open to bleed out any air that is in the system and it will automatically close when it detects water. The small cap on top of the bleeder should be left slightly loose to allow the valve to function properly. The high-pressure relief valve is supplied in the event the internal tank pressure exceeds the design pressure. Standard tanks are designed for a 50 PSI working pressure. Because normal operating pressure may fluctuate, the emergency valve will open at 75 PSI. If the valve opens because of a high-pressure condition, it must be manually reset by pushing the small lever downward. Assemble as per illustration below:

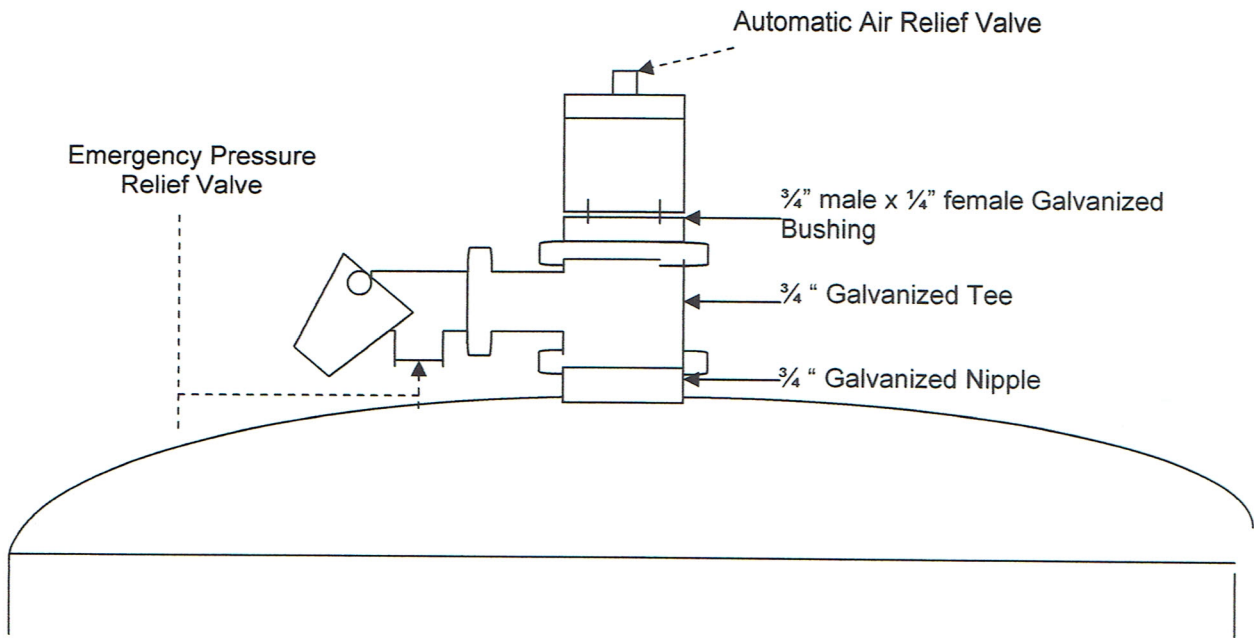
TANK INSTALLATION (cont'd)

3. **GAUGE PANEL AND TUBING INSTALLATION:** All components to install and tube the gauge panel assembly are supplied in the accessory box. To install gauge panel, first mount gauges in the panel and secure with a 2" flat bar brace across the back of both gauges. Lightly snug flat bar against back of gauges using $\frac{3}{4}$ " nut and $\frac{3}{4}$ " threaded rod (supplied). Attach the gauge panel assembly to the mounting bracket using the same $\frac{3}{4}$ " threaded rod and the second $\frac{3}{4}$ " nut (supplied). Attach the gauge panel assembly to the upper tank flange using the mounting bracket and two of the tank flange bolts.

CAUTION: Do not over tighten the pressure gauge support bar lock nut. Hand-Tighten Only! Too much force on the pressure gauges may crack the glass face on the pressure gauges.

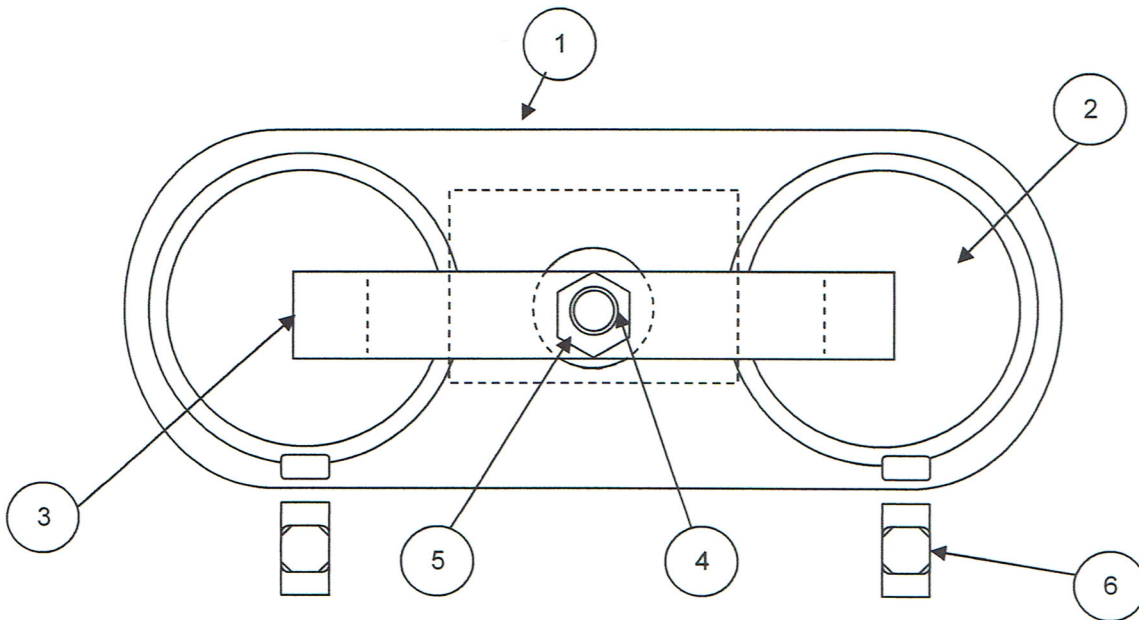

Differential Gauge Panel #15160		
Reference Number	Quantity	Description
1	1	Gauge Panel
2	2	0 – 60 PSI Pressure Gauges
3	1	Support Bar, Stainless Steel
4	1	$\frac{3}{4}$ " I.P.S. x 3" Threaded Rod
5	2	$\frac{3}{4}$ " I.P.S. Galvanized Lock Nut
6	2	$\frac{1}{4}$ " I.P.S. x $\frac{1}{4}$ " Tube Compress Fitting

TANK INSTALLATION (cont'd)

The Influent and Effluent gauge panel and tubing may now be installed. In the packing crate, locate two ¼" female compression fittings. The tubing will be cut from the roll supplied in the packing crate. Install one ¼" female compression fitting onto each gauge.

When installing the fitting, hold the gauge with a wrench, not by the glass. Connect the gauge marked "Effluent" to the ¼" compression fitting previously installed on the effluent manifold. Connect the gauge marked "Influent" to the ¼" compression fitting previously installed on the influent manifold.

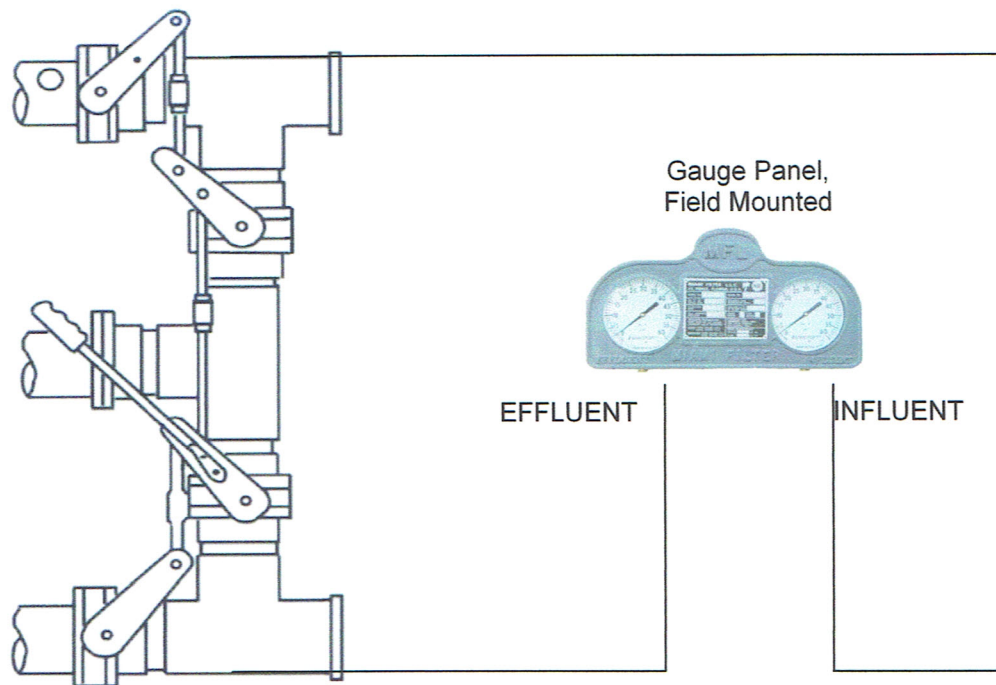
GAUGE PANEL TUBING CONNECTION DETAIL

MIAMI FILTER INC.
TANK INSTALLATION (cont'd)

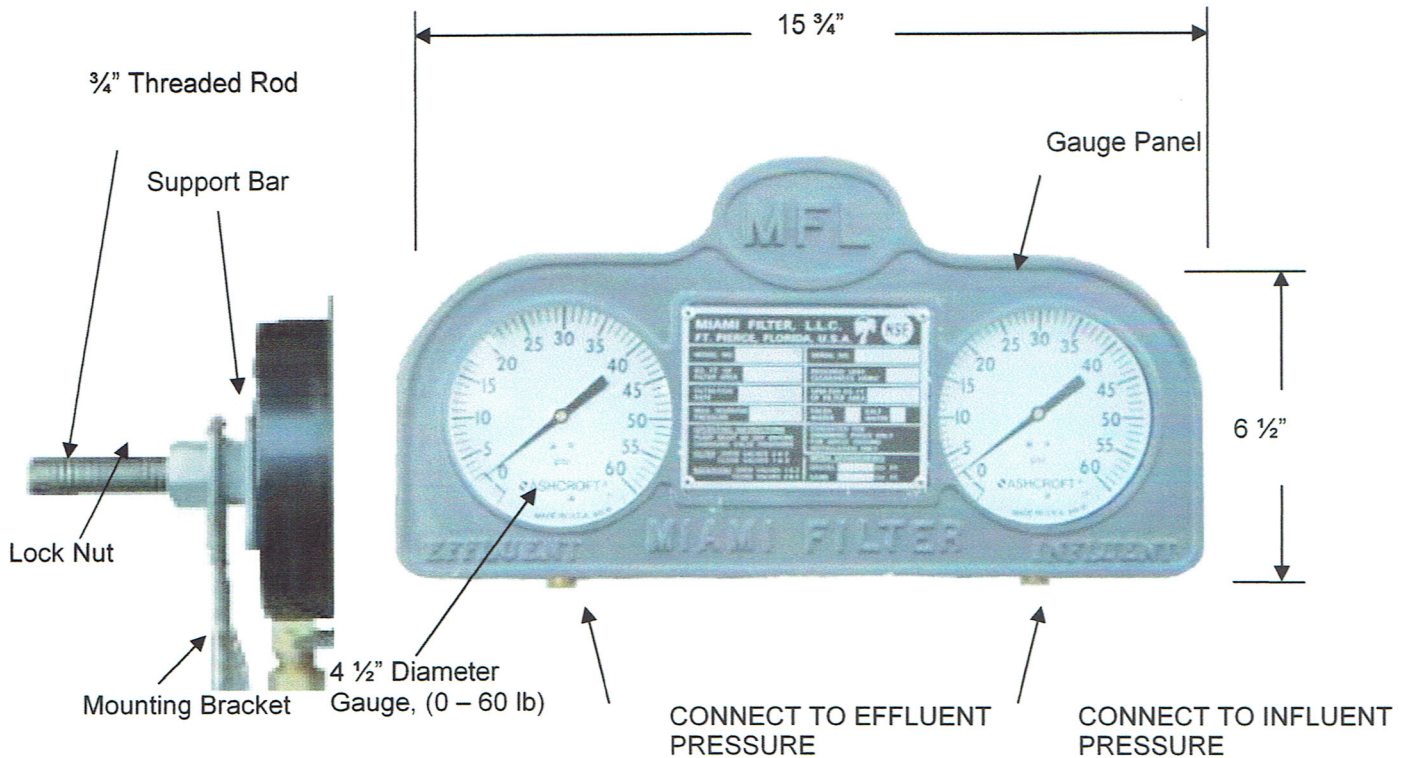

Filter Gauge Panel:

Gauge panel consists of two 4 1/2" diameter pressure gauges mounted in cast aluminum support panel. A 3/4" threaded rod and lock nuts are provided for the mounting of the panel. The panel has the words "Effluent" and "Influent" integrally cast under each gauge respectively.

Pressure gauges are typically 0 – 60 PSI reading with a 1/4" MIPS bottom connection.

SIGHT GLASS INSTALLATION

The backwash sight glass may now be installed. On some units the sight glass is factory installed on the upper tee on the manifold. On larger units, the sight glass and a section of pipe with a 1 1/2" threaded port is supplied. For field installation, the sight glass assembly should be installed as close as possible to the filtration system and may be installed in the horizontal or vertical position. Note the position of the diverting baffle in the diagram below.

CAUTION: DO NOT EXCEED 50 PSI.

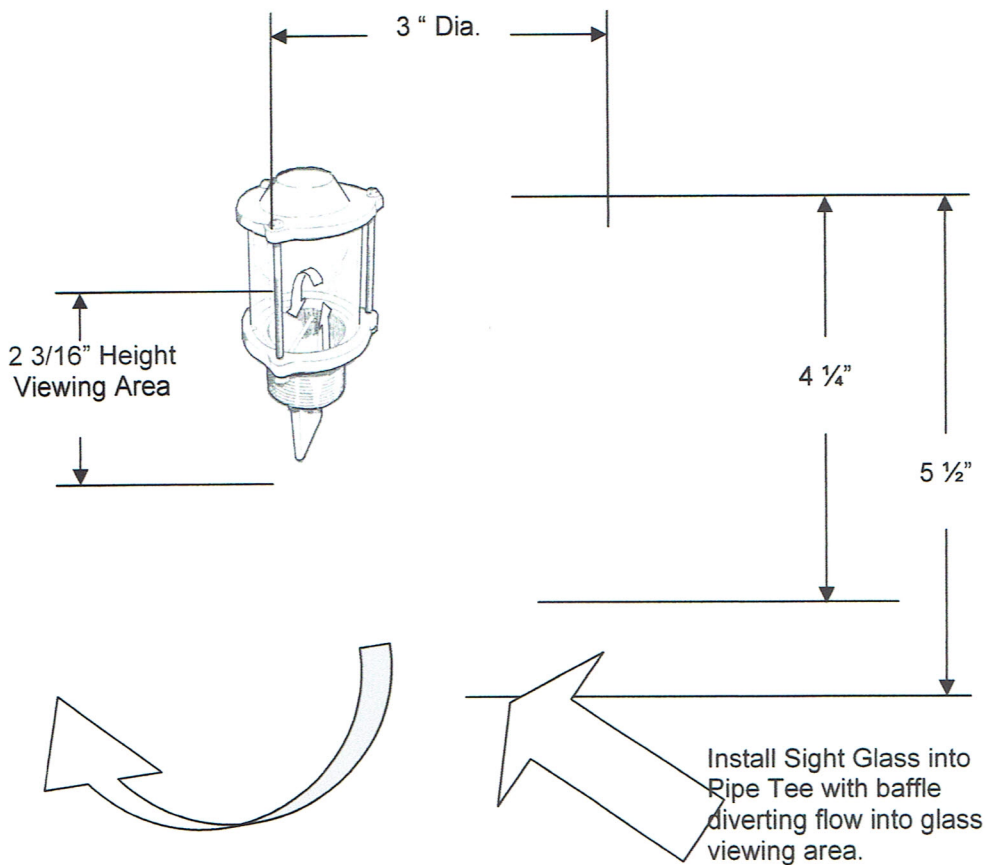

SIGHT GLASS

ADDING MEDIA TO A SAND FILTER

The filter media should consist of washed, clay-free gravel and sand. The gravel should be 1/8" x 1/4" and the sand should be #20 or 0.45 to 0.55mm type. Care should be taken when adding the media so that the lower lateral collection system is not damaged. All filtration systems are shipped with the internal piping installed and braced for support. Plastic shipping supports can remain in place and do not require removal.

IMPORTANT: Before adding media, the internal plumbing should be inspected for damage during shipment – *this is a very critical step*. Be sure to repair any damaged internal plumbing prior to loading media.

Fill the tank with water to approximately one foot above the lower collection system plumbing. After adding water, carefully pour in the required amount of gravel through the manhole. After gravel is added, level the surface through the manhole using a shovel, rake or 2 x 4 board. After loading and leveling the gravel, the sand should be installed in the same manner. After all media is loaded and leveled, the manhole cover and gasket should be installed and tightened. **NOTE:** The manhole is connected by a safety chain to prevent it from falling onto the internal piping while media is being loaded.

ANNUAL MAINTENANCE AND INSPECTION

It is good maintenance to inspect and clean the sand at least once a year by skimming the sand bed with a rake or loosening by stirring the surface of the sand, then backwashing. If necessary, accumulations of hair or other foreign material that will not backwash can be removed by skimming about 2" of sand off the surface and replacing with #20 filter sand. This will ensure effective operation for the following season. Occasionally, sand may cake or solidify due to hard water conditions. If this occurs, Hydrochloric Acid (also called Muriatic Acid) and agitation will loosen up the sand. Water conditions in the pool should be adjusted to prevent calcification.

After 6 or 8 weeks of service, a marked improvement in length of cycle and flow rate will be noticed. This is due to the natural alignment of sand particles caused by backwash.

OPERATING INSTRUCTIONS**VCOM-SERIES BUTTERFLY VALVE UNITS 2 ½" THRU 10" WITH MANUAL CONTROL**

IMPORTANT: ALWAYS TURN OFF PUMP WHEN OPERATING VALVES OR CLEANING PUMP STRAINER.

1. INITIAL START UP; NEW POOL

VALVE POSITIONS: Open valves # 1 and # 2. Close valves # 3 and # 4.

PURPOSE: To remove dirt and debris from pipes.

EXPLANATION: When plumbing is attached as per illustration, water will pass from pump directly to waste, permitting thorough cleaning of all suction pipelines. Draw water from one suction line at a time (at least 1 full minute for each line), then clean pump strainer and repeat with all suction lines open until strainer remains clean – this will indicate that the pipes are clean.

2. BACKWASHING

VALVE POSITIONS: Open valves # 1 and # 3. Close valves # 2 and # 4.

PURPOSE: To clean sand and gravel and remove trapped impurities.

EXPLANATION: When plumbing is attached as per illustration, water will pass from pump to the bottom of the filter bed and scrub the media. This operation should be performed at least once a week for a period of 3 to 5 minutes or until sight glass (located in the waste line) shows reasonably clear water. Heavier bather load may require more frequent backwashing until the particles of sand align themselves.

3. FILTERING

VALVE POSITIONS: Open valves # 2 and # 4. Close valves # 1 and # 3.

PURPOSE: To filter pool water

EXPLANATION: As pool water is forced through the sand bed from top to bottom, turbidity (cloudiness) and suspended matter is filtered from the water by getting caught in the media. As more dirt and suspended matter fill the spaces between sand particles, water flow will be reduced. The water pressure above the sand bed will increase and the pressure below the sand bed will decrease, eventually requiring a backwash. Differential pressure can be noted on the gauge panel.

CAUTION: DO NOT CHANGE VALVE SETTINGS WHEN PUMP IS OPERATING.

ILLUSTRATION OF TYPICAL VALVE NEST
 (Shown here in "BACKWASH" Mode)

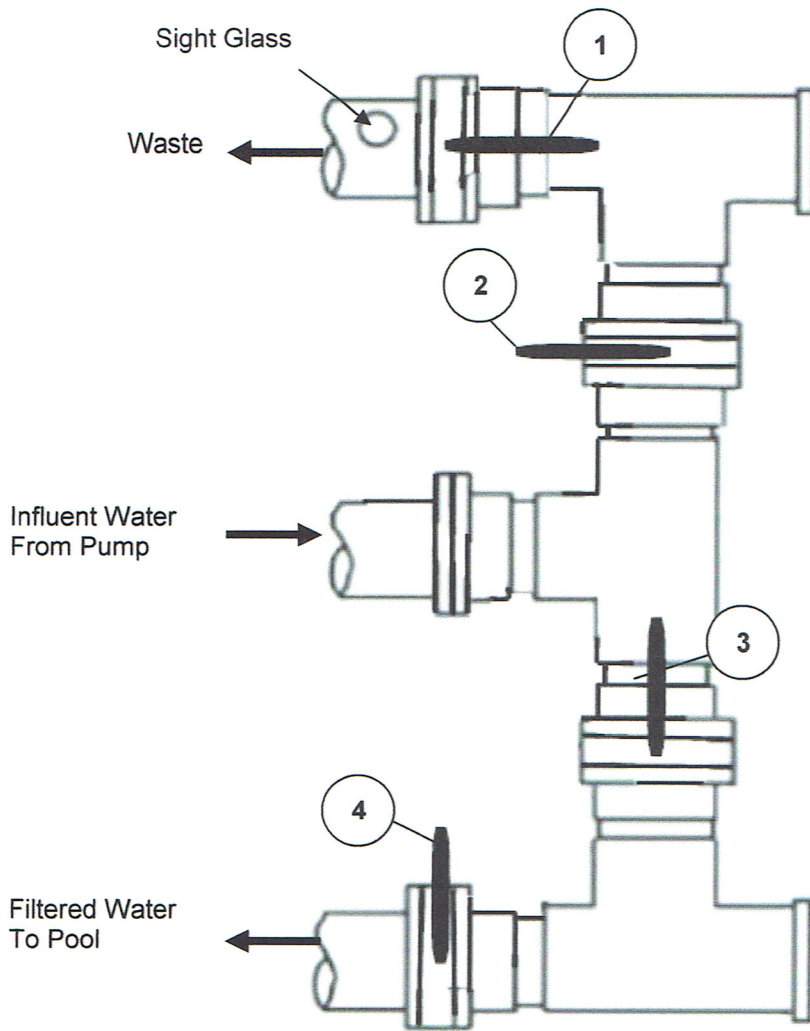

Legend: Valve Positions

1		CLOSED
	—	OPEN
2		OPEN
	—	CLOSED
3		OPEN
	—	CLOSED
4		CLOSED
	—	OPEN

OPERATING INSTRUCTIONS
SINGLE LEVER VALVE CONTROL UNITS

NOTE: Single lever operating restricts valve functions to “Filter” and “Backwash” modes only. On filters equipped with a single lever control, the operating sequence is as follows:

FILTRATION: Valve handle pushed upward as far as possible and with the supplied Lock pin inserted.

BACKWASH: Remove Lock Pin and pull single lever valve downward as far as possible until resistance is felt. Hold in the backwash position approximately 3 to 4 minutes or until the backwash sight glass appears reasonably clear.

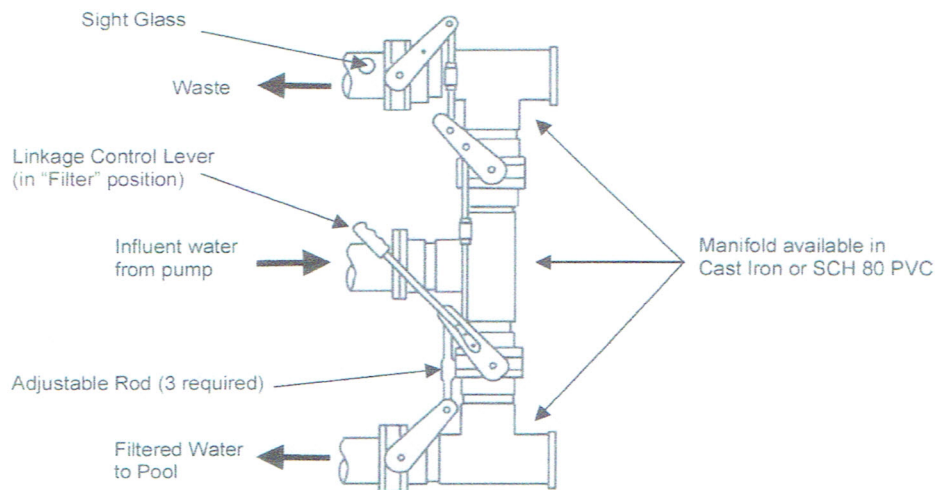

NOTE: When the single lever control is placed in the “FILTER” position, the supplied lock pin **MUST** be inserted in the pre-drilled holes located in valve and clevis # 1. If this procedure is not followed, pump vibration could cause the single lever control to move from the “Filter” position to the “Backwash” position, resulting in massive water loss.

PROCEDURE FOR ADJUSTING LINKAGE: All butterfly valves supplied with the system have a slot on the end of the stem or shaft indicating the position of the disc.

To adjust linkage, remove the respective clevis, bearing, bolt and nut. Place the indicator mark in desired position. Loosen the respective jam nut. The linkage may now be extended or retracted to the necessary length into the adjustment coupling.

Replace the bearing bolt and nut. The assembly is now ready for operation.

OPERATING INSTRUCTIONS
SINGLE LEVER VALVE CONTROL UNITS (Cont'd)

INSPECTION AND MAINTENANCE: All moving parts on the single lever control should be inspected monthly for fatigue or stress fractures. This is because chemical conditions of water can sometimes cause corrosion. If corrosion occurs on the butterfly valves, more torque will be required to operate them. This higher torque requirement will result in a heavier load upon the single lever control assembly, especially on the shear pins that connect the clevis to the butterfly valves. These pins should be monitored for signs of corrosion or fatigue and should be replaced as necessary. All moving parts on the linkage should be greased or coated with protective spray monthly.

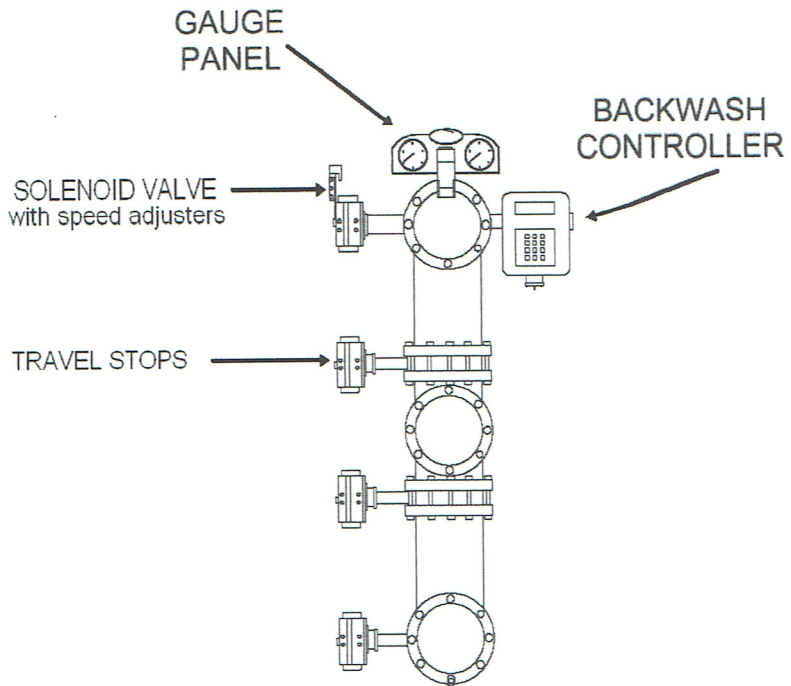

AUTOMATIC OPTION

AUTOMATIC OPTION

DRAIN AND WINTERIZING PORTS

Located on the bottom head of all VCOM-series filter tanks are two ports as follows.

ONE 3" MEDIA DRAIN PORT: this port is used only when necessary to drain all the media out of the filter tank.

ONE 1 ½" WINTERIZING DRAIN PORT: this port is screened on the inside of the filter and is used to drain the water completely without draining any of the media.

CAUTION: Before removing the drain or winterizing plugs, ensure that the pump is off and bleed all pressure from the filter system. To bleed air pressure, open manual or automatic bleeders and check pressure gauges to verify that there is no pressure left in the system.

DANGER: FAILURE TO BLEED PRESSURE FROM TANK BEFORE REMOVING EITHER PLUG CAN RESULT IN SERIOUS INJURY OR FATALITY, as the plug can pop out with very high velocity if the tank is still under pressure.

REMEMBER: SAFETY FIRST

EMERGENCY RELIEF VALVES

Supplied with each Miami Filter unit is a ¾" Pressure Relief Valve (PRV), included in the components box. This valve should be installed at the top center coupling on the top head. The PRV was designed strictly as an automatic emergency safety device. It should never be used as an operating control. The valve is ASME-rated and has been pre-set by the factory to open at 75 PSI. Repair or alteration of this valve in any way is prohibited.

CAUTION: If the PRV has to be replaced for any reason, ensure that the pump is off and bleed all pressure from the filter system. To bleed air pressure, open manual or automatic bleeders and check pressure gauges to verify that there is no pressure left in the system.

DANGER: FAILURE TO BLEED PRESSURE FROM TANK BEFORE REMOVING PRV CAN RESULT IN SERIOUS INJURY OR FATALITY, as the PRV can pop out with very high velocity if the tank is still under pressure.

FINAL PAINTING OF VCOM-SERIES TANKS

All standard VCOM-Series Filter tanks are coated with high solids Zinc paint. To activate the corrosion warranty, the tanks should be top-coated with a durable acrylic enamel, polyurethane, or epoxy paint.

Paint will help protect the exposed steel surface by preventing corrosive agents from coming in contact with the surface of the filter vessel.

REQUIRED QUANTITY OF PAINT

Theoretically, 1 gallon of paint will cover 1,600 square feet of surface with 1 mil (0.001) inch thick coat when it is *wet*.

The *Dry Thickness* is determined by the solids (non volatile) content of the paint, which can be found in the specifications on the label, or in the supplier's literature. For example, if the content of solids (by volume) is 60%, then the maximum dry coverage to maintain a dry film thickness of 1 mil will theoretically be $1600 \text{ sq ft} \times 0.60 = 960 \text{ sq. ft. per gallon}$.

.TROUBLESHOOTING GUIDE

There are no moving parts inside any Miami Filter vessel, which eliminates the need for frequent maintenance.

MOST COMMON PROBLEMS

There are two common problems that can occur with a filter vessel;

1. MEDIA DISCHARGED INTO POOL

CAUSES: A. Underdrain damaged or incorrectly installed.
B. Incorrect media used (i.e., media is too fine).

SOLUTION: A. Remove media (using dump port), inspect underdrain and repair if necessary and re-install media
B. Check media size. If incorrect size was used, remove (using dump port) and replace with proper grade.

2. POOL WATER NOT CLEARING UP (i.e., remains cloudy or dirty)

CAUSES: A. Incorrect media used.
B. Flow rate in excess of 20 GPM.
C. Problem with pool chemistry.
D. Mud ball.
E. Problem with original water source.

SOLUTION: A. Inspect media grade. If incorrect, remove and replace with correct grade.
B. Check flow rate and adjust if necessary.
C. Consult local water chemist.
D. Consult factory service representative.
E. Special pre-treatment or special post-treatment (after filling) of pool water may be required. Consult local water chemist or factory representative.

PROCEDURE FOR ADJUSTING LINKAGE

All butterfly valves supplied with the system have a slot on the end of the stem or shaft indicating the position of the disc.

To adjust linkage, remove the respective clevis, bearing, bolt and nut. Place the indicator mark in desired position. Loosen the respective jam nut. The linkage may now be extended or retracted to the necessary length into the adjustment coupling.

Replace the bearing bolt and nut. The assembly is now ready for operation.

TROUBLESHOOTING GUIDE (Cont'd)

PROBLEM: FREQUENT BACKWASH INTERVALS	
PROBABLE CAUSES	SOLUTION
A. Backwash flow or duration not adequate.	A. Re-adjust backflush flow and/or increase duration of backflush.
B. Insufficient media depth.	B. Add media to recommended level.
C. Incorrect media used – too fine.	C. Replace with recommended media
D. Pressure differential switch set too low.	D. Re-adjust pressure switch to 15 PSI higher than clean bed differential.
E. Higher concentration of contaminants in water source.	E. Reduce flow rate
F. Pool chemistry not adequate in preventing algae growth.	F. Maintain proper pool chemistry or consult pool service technician.

PROBLEM: CONSISTENTLY HIGH PRESSURE DIFFERENTIAL – SYSTEM WILL NOT BACKWASH	
PROBABLE CAUSES	SOLUTION
A. Incoming air pressure below 50 PSI – automatic backwash valves cannot activate (automatic models only)	A. Correct low air pressure condition; supply 50 PSI to microprocessor stager.
B. Media level too high, causing inadequate restrictive backwash flow.	B. Remove media to recommended level.

PROBLEM: SAND LOSS TO WASTE	
PROBABLE CAUSES	SOLUTION
A. Backwash rate is too high.	A. Reduce backwash flow rate.
B. Improper sand size.	B. Replace with recommended grade.

TROUBLESHOOTING GUIDE (Cont'd)

PROBLEM: CONTINUOUS BACKWASH FLOW TO WASTE	
PROBABLE CAUSES	SOLUTION
A. Obstruction inside valve preventing valve from closing waste port.	A. Remove obstruction.
B. Damaged valve seat.	B. Replace valve seat.
C. Single lever control not in the "Filter" position.	C. Return single lever control to "Filter" position and secure with lock pin.

PROBLEM: MEDIA SAND APPEARS DOWNSTREAM	
PROBABLE CAUSES	SOLUTION
A. Incorrect media used – too fine	A. Replace with recommended media.
B. Underdrain system broken or damaged.	B. Repair or replace.
C. Air in filter(s) causing bed disruption.	C. Check Air Relief Valve operation. Replace if necessary.
D. Excessive flow through filter	D. Reduce flow rate.

PROBLEM: SYSTEM NOT BACKWASHING	
PROBABLE CAUSES	SOLUTION
A. Inadequate air pressure to actuator (Automatic Models only).	A. Supply minimum 50 PSI air pressure to actuator.
B. Butterfly valve leaking internally.	B. Replace butterfly disk seat.
C. Power to microprocessor disrupted.	C. Check and/or restore power to microprocessor.

MIAMI FILTER, INC.
7384 COMMERCIAL CIRCLE
FORT PIERCE, FLORIDA 34951
Ph: 772-466-1440 Fax: 772-466-0364
www.miamifilter.com

LIMITED WARRANTY FOR VCOM MODELS

This filter system was factory inspected before shipment. To the original purchaser of this system, MIAMI FILTER, INC. warrants this product to be free of defects in material and workmanship for a period of one (1) year. Thereafter, the filter vessel and PVC internals carry a five (5) year warranty on a prorated basis.

The manufacturer's obligation under this warranty shall be limited to the repair or replacement (at the manufacturer's option) of any part that, upon examination by the manufacturer proves to be defective in materials and/or workmanship under normal usage. All such repairs or replacements to be performed by the manufacturer upon return pre-paid to the manufacturer.

This warranty is expressly conditioned upon the correct installation and application of the product in the manner recommended by the manufacturer, where installation and application is the responsibility of the purchaser.

Parts which fail or become defective during the warranty period, except as a result of freezing, negligence, improper installation, use, or care, shall be repaired or replaced at the manufacturer's option, without charge, within 90 days of the receipt of defective product, barring unforeseen delays.

MIAMI FILTER, INC. shall not be responsible for cartage, removal and/or re-installation labor or any other such costs incurred in obtaining warranty replacements.

The forgoing warranty does not apply to components manufactured by other manufacturers. For such components, the warranty established by the respective original equipment manufacturer (OEM) will apply.

Some States do not allow limitations on how long an implied warranty lasts, or the exclusion or limitation of incidental or consequential damages, so the above limitations or exclusions may not apply to you.

This warranty gives you specific legal rights and you may also have other rights that vary from State to State.

The remedy provided by this warranty shall be exclusive.

Respectfully,

Shane Mulvey
COO, Miami Filter, INC.

OPERATIONS DAILY LOG

OPERATING LOG FOR: _____ WEEK ENDING: _____

	PRESSURE		pH	Chlorine PPM	CHEMICAL ADDITION (LBS)			Backwash Time	TEMPERATURE			Flow Rate	Filter Rate	Bather Load	
	Influent	Effluent			Acid	Soda Ash	Chlorine		Air	Water					
SAT	AM														
	PM														
SUN	AM														
	PM														
MON	AM														
	PM														
TUES	AM														
	PM														
WED	AM														
	PM														
THUR	AM														
	PM														
FRI	AM														
	PM														

PACKING LIST

VCOM-SERIES VERTICAL TANKS WITH PIPING

Customer:		
Filter Type:		
Quantity:		
ITEM	Required Per Tank	Total Shipped
Instruction Manual	1	
0 – 60 PSI Pressure Gauges	2	
GAUGE Mounting Panel with Data Plate	1	
GAUGE Panel Mounting Brackets	1	
Poly tubing 1/4"	2	
Poly Tubing Female Connector	2	
Ply Tubing Male Connector	2	
Backwash Sight Glass 1 1/2"	1	
Flange Gaskets – Size _____	_____	
Hex Head Bolts – Size _____	_____	
Hex Nuts – Size _____	_____	
Washers – Size _____	_____	
Tee with Nipple 3/4"	1	
Automatic Relief Valve with Busing	1	
Pressure Relief Valve (PRV) 75 PSI	1	
Actuators	4	
Compressor	_____	
Other(Specify)	_____	

Packed By: _____ Date: _____

Tank Serial Numbers: _____

PLEASE REPORT ALL SHORTAGES PROMPTLY

Notes:

FilterMinder

Users's Manual

Rev 2

December 10, 2009

Table of Contents

	Page
FilterMinder Capabilities	3
Backwash Sequence	3
Front Panel Features	4
Access Control	5
Operation	6
Backwash Now	6
View Count	6
View Alarms	6
Contrast Adjust	6
Pump/Heat Control	7
Set Auto Mode	7
Manual Only	7
Time Interval	7
Inlet Pressure	7
External Switch	7
System Setup	8
Interval Setpoint	8
Pressure Setpoint	8
Set Zero Pressure	8
Baseline Pressure	9
Backwash Duration	9
Interfilter Delay	9
Valve Shift Delay	9
Cool Down Delay	9
Surge Delay	10
Number of Filters	10
Valve Shift Mode	10
System Status	10
Field Wiring Details	11
Power	11
Fuse	11
Pressure Sensor	11
Pump, Heater and Priority Valve	11
Relay Contacts	13
Hardware Specifications	14
Electrical Specifications	14
Environmental Specifications	14

FilterMinder Capabilities

A Pool's filter system is often the most overlooked part of a pool, yet a poorly maintained filter can cause water purity problems, increased energy usage and premature pump failure.

The FilterMinder is designed to monitor filters for proper operation and then clean these filters as needed to assure proper filter system performance. The FilterMinder does this by measuring either the time since the filters were last washed or differential pressure across the filters and then automatically sequencing valves and relays as necessary to perform a complete backwash of single or multiple filter systems. Initiation and execution of this backwash sequence can be totally automatic, requiring no operator intervention.

If fully automatic operation is not desirable, the FilterMinder can be configured to only monitor the filter system and display its status. The bar graph indicator on the FilterMinder can then be used as a visual indication of when a backwash is required and pool maintenance personnel can initiate the backwash sequence from the keypad (semi-automatic operation). Once initiated, the backwash will advance automatically to assure that all valves and relays are sequenced correctly and proper timing is executed to assure a complete backwash of all filters. This frees maintenance personnel to perform other pool maintenance tasks while the filter system is backwashing.

Backwash Sequence

Once a backwash operation is initiated, FilterMinder first turns off the heater and any other device such as a chemical feeder that is attached to the Heat relay. The controller waits for the heater to cool off and all chemicals to flush into the pool and then shuts off the Pump relay. The Valve 1 output is now energized. The controller then waits for all diaphragm valves fed from the Valve 1 actuator to fill. The Pump is then turned on and backwash of the first filter begins. When this filter is clean, the Pump relay and the Valve 1 output are turned off and the controller waits for all diaphragm valves to return to their normal position in preparation for backwashing of the next filter. If desired, the controller can be programmed to pause at this point to allow waste water to disburse before moving on to the next filter (this is called the Interfilter delay). If this option is chosen, the pump will turn back on during this delay to resume filtering while waiting for effluent to drain. When it is time to advance to the backwash of Filter 2, the Pump relay is again turned off, the Valve 2 output is energized and the backwash sequence continues as it did for Filter 1. Filter systems containing up to 3 filters can be backwashed in this manner. After the last filter in the system is backwashed, the Pump and Heat relays are energized to resume normal pool operation until the next backwash is required. If there are less than 3 filters in the system, the Valve 3 output is energized for each filter backwash period and can be used to run a pressure boost pump or electrically actuated priority valve

In addition to the above standard sequence, FilterMinder can be configured to leave the pump and heater on through the backwash operation. Many operators feel that this modified sequence reduces wear on the pump associated with starting and stopping.

Front Panel Features

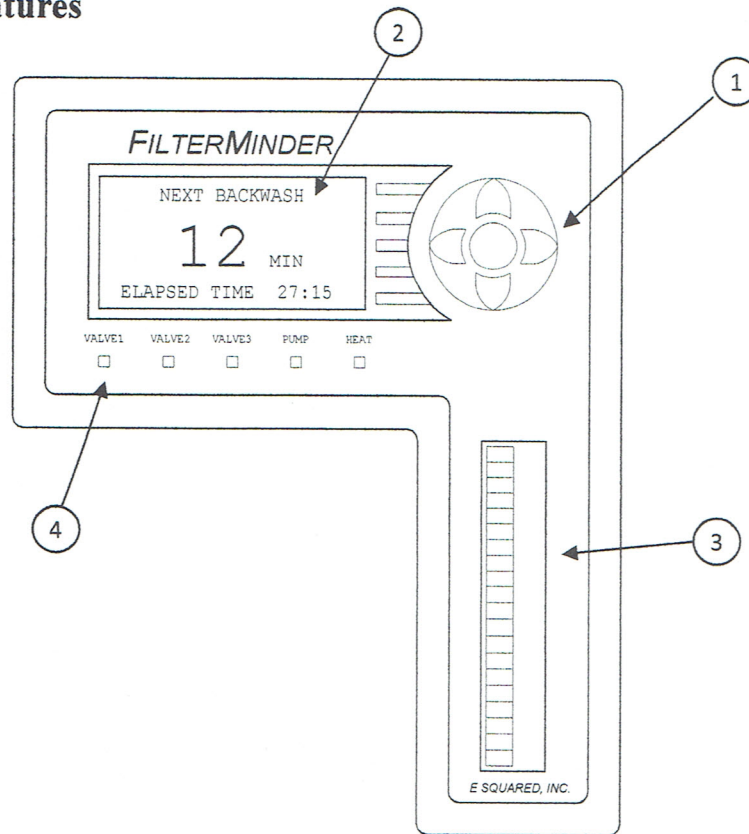

Figure 1

- ① The key pad contains five keys for navigating the menu system and modifying system parameters. Press the center “Select” key to enter the menu system. The “Up” and “Down” keys can now be used to scroll through the menu to the desired function. Then the Select key can be pressed again to select this function. Once selected, the parameters of interest can be modified using the Up and Down keys. On numeric parameters, these keys can be held down to increase or decrease automatically. Once the desired value is reached, the Select key can be used to save the new value and return to the menu. Similarly, the “Left” and “Right” keys can be used to navigate the menu system. The Right key will take you forward one level in the menu system and the Left key will take you back.
- ② The 128 x 64 pixel LCD display provides easy to read information about the current system status and provides a helpful interface for changing system parameters. Important values are displayed in large characters for easy viewing from a distance. Where appropriate, brief instructions are presented to the user. The display is transreflective for easy viewing in bright sunlight and contains a backlight for viewing in dim ambient lighting.
- ③ The bright 20 element LED bar graph provides a graphical representation of filter system capacity. A new, clean filter will show as empty (no bars lit). As the filter accumulates particulates, the bar graph display increases until the filter reaches capacity (all bars lit). The first 16 bars are green to show normal operation. The last four bars are red to indicate that the filter needs to be backwashed, or will soon be backwashed if automatic backwash is selected.
- ④ These Five Status LEDs provide information on the state of the Pump, Heater, Valve actuators and any other device connected to the Valve3 output.

Access Control

The FilterMinder enclosure contains relays that can switch high currents at up to 250 volts. The latches on this enclosure are designed to accept a padlock to prevent unauthorized access.

WARNING

It is expected that some form of lock be used for safety as well as security and that access to the wiring inside the enclosure be limited to qualified service personnel.

Since the FilterMinder display and keypad are accessible from the outside of the case, some further means of preventing inadvertent or unauthorized operations of the controller is required. Three different levels of security have been provided. These security levels are set via two switches inside the case. These switches are located on the back side of the enclosure door just above the wiring connector.

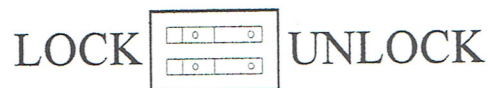

Figure 2

The first level of access allows all operations to be performed from the keypad. All parameters can be viewed and changed and backwash cycles can be initiated as desired. This level of access is selected by placing both switches in the UNLOCK position.

The second level of access allows backwash operations to be performed from the keypad and allows all parameters to be viewed, but does not allow the operator to change any of these parameters. Attempts to save altered parameters will result in the message “MEMORY IS LOCKED”. This level of access is selected by placing the top switch in the UNLOCK position and the bottom switch in the LOCK position.

The third level of access does not allow any operations from the keypad. The parameters can be viewed, but attempts to save will result in the message “MEMORY IS LOCKED” and attempts to execute a backwash or manipulate the pump or heater will result in the message “FRONT PANEL OPERATIONS ARE CURRENTLY LOCKED OUT”. This level of access is selected by placing both switches in the LOCK position.

If a Remote Access package has been installed, all functions can be accessed remotely regardless of security switch settings. Remote access relies on Password protection to prevent unauthorized access from the web interface. See the Remote Access Package documentation for details of this capability.

Operation

Press the center of the keypad to enter the operations menu.

BACKWASH NOW

This selection allows you to start a backwash from the keypad. The lower line on the display tells you that the FilterMinder is currently **FILTERING** pool water. Press the Select key once to start the backwash cycle. The system will now advance through the backwash cycle automatically, displaying the current stage of the backwash at the top of the display and counting down the seconds until the next stage at the bottom of the display. If you wish to abort this stage and move on to the next, press the Select key to advance. If you wish to terminate the backwash cycle and return to **FILTERING**, press the Down key to point to **CANCEL** and then the Select key to execute this request.

VIEW COUNT

FilterMinder keeps a log of the number of backwash cycles that have been completed. This count is useful to verify that a unit that is configured to backwash based on pressure settings is not backwashing too frequently. Excessive backwash operations could indicate a problem with the filter system or could be an indication that the trip pressure is set too low or that the surge delay needs to be increased. The log can be cleared to zero from this screen if desired.

VIEW ALARMS

The controller has a safeguard built in to prevent excessive discharge of pool water.

When backwash is initiated by differential pressure, if the setpoint is set too close to the normal operating pressure, the FilterMinder will perform one backwash cycle after another. This situation has the potential to empty large quantities of pool water out of the waste line while never addressing the actual problem. In situations like this where less than five minutes elapse between subsequent backwash operations, after three backwash cycles the Pump and Heat outputs are turned off and a message is displayed indicating why the pool was shut down.

If this happens, navigate the menu system to the **VIEW ALARMS** screen. The current alarm status will be displayed. Select **YES** to clear the alarm flags. The Pool will then re-start automatically.

CONTRAST ADJUST

The LCD display used in the FilterMinder is designed to provide excellent readability in both dim and bright ambient light situations and over all specified operating temperatures. The user has the ability to maximize this readability by adjusting the bias voltage of the LCD for maximum contrast in their particular installation. Use the Up and Down keys to adjust the display for the best viewing, then press the center Select key to save this new bias voltage in nonvolatile memory.

PUMP/HEAT CONTROL

The Pump and Heat output relays can be turned on and off as desired from this screen. Interlocks are provided to prevent thermal stress on the Heater. The Heater cannot be turned on unless the Pump is running. The Pump cannot be turned off if the Heater is running. After the Heater is turned off, a sufficient "Cool Down" interval must elapse before the Pump can be turned off. Messages indicating these interlocks are displayed if a disallowed operation is attempted.

SET AUTO MODE

Four different choices are available for backwash cycle initiation:

MANUAL ONLY With this selection, backwash operations will only commence if initiated from the BACKWASH NOW screen.

TIME INTERVAL With this selection, filters will be backwashed periodically based on a user selected period of time. Selection of this mode will automatically advance you to the INTERVAL SETPOINT screen so that the currently configured backwash interval can be viewed and adjusted. The interval selected is the number of seconds from the start of one backwash cycle to the start of the next backwash cycle. When in this mode of operation, the bar graph indicates the amount of time remaining until the start of the next backwash. Each illuminated bar indicates that 5% of the time remaining until the next backwash has elapsed. When all bars are lit, a new backwash operation will be initiated automatically.

PRESSURE CHANGE As the filter bed becomes clogged with debris from the pool, the pressure differential between the inlet and outlet of the filter increases. This decreases the flow through the filter and puts additional strain on the pump motor. By setting a trip pressure slightly above the normal operating pressure differential of a clean filter system, the filters will be cleaned automatically as needed to maintain this normal filter differential. Selection of this mode will automatically advance you to the PRESSURE SETPOINT screen so that the currently configured trip pressure can be viewed and adjusted. Be careful to select a trip pressure sufficiently above the normal operating filter differential to balance water usage with the desire for a clean filter system. When in this mode of operation, the bar graph indicates the current pressure difference between the inlet and outlet pipes of the filter system as a percentage of the difference in pressure between a clean new filter and the configured trip pressure. A quick glance at the bar graph will let you know how dirty the filter system currently is.

EXTERNAL SWITCH If you desire to connect the FilterMinder to a set of relay contacts controlled by a facility monitor or SCADA system, this other system can be used to trigger a backwash using this mode of operation. Disconnect the differential sensor wires at the three terminals marked Com, Sensor and +5 VDC and connect the switch or dry relay contacts between the Sensor and +5 VDC terminals. The SURGE DELAY is still in effect

for the EXTERNAL SWITCH input, as is a 10 second de-bounce timer. Set SURGE DELAY to zero seconds if this input is coming from anything other than a differential pressure switch and assure that the switch remains closed for a minimum of 10 seconds to initiate a backwash. When EXTERNAL SWITCH is selected for the auto mode, the bar graph display will illuminate briefly when the external switch is closed but otherwise will be inactive (no bars lit).

In any mode of operation, backwash can still be manually triggered from the Remote Access package, if installed. Also, backwash operations can always be initiated from the keypad unless front panel operation is locked out by the LOCK/UNLOCK switches inside the enclosure.

SYSTEM SETUP

All time intervals and many other operating modes and parameters can be configured using this sub-menu. These parameters have been grouped here because once the system is configured, it is not generally necessary to access these parameters in the course of normal pool operations.

INTERVAL SETPOINT This parameter is also available from the SET AUTO MODE menu if TIME INTERVAL is selected. The value selected is the number of minutes from the start of one backwash cycle to the start of the next. Valid values range from 5 to 9999 minutes (6.9 days). The interval should not be too short or it will trip the WE ARE BACKWASHING TOO OFTEN alarm message. To select an appropriate value, perform a backwash cycle. Then, using some means of measuring filter system inlet pressure, measure the amount of normal pool operation time required to increase this pressure by about 10 PSI. This should provide a reasonable starting place to set the interval setpoint.

PRESSURE SETPOINT This parameter is also available from the SET AUTO MODE menu if INLET PRESSURE is selected. The value selected is the filter system inlet pressure that must be met or exceeded for a SURGE DELAY period of time to cause a backwash cycle to be initiated. Valid values range from 0 to 50 PSI. The trip point should not be too close to normal operating pressure or it will trip the WE ARE BACKWASHING TOO OFTEN alarm message. A value between 5 and 10 PSI above the pressure observed on a clean filter is usually acceptable.

SET ZERO PRESSURE Small differences in location between the inlet and outlet pressure sensing ports on the system piping can result in a small head pressure being indicated by the filter differential displayed on the FilterMinder. A system variable called "offset" can be adjusted from this screen to set the filter differential reading to zero. To make this adjustment, turn the pump off to stop water flow through the filter system. Then use the Up and Down keys to find what value of offset results in a pressure reading that bounces equally between 1 and 0. Then find what value of offset results in a pressure reading that bounces equally between 0 and -1. Set the offset to half way between these two values. This value will be saved permanently when you exit this screen. Values

between 200 and 700 are allowed, which should provide an adjustment of +/- 5 PSI. If more range than this is needed to achieve a display of 0 PSI, there may be a problem with the pressure sensor.

BASELINE PRESSURE The bar graph is used to indicate the current health of the filter system. To provide an accurate indication, FilterMinder must be told what minimum inlet pressure to use as a reference or baseline. Valid values range from 0 to 50 PSI. This parameter should be set at the lowest pressure achieved with clean, new media in the filter system. As the media ages and gets contaminated or ground down from usage, the pressure observed just after a backwash operation will be found to increase, indicating that the media is starting to wear out. Observing the bar graph immediately after a backwash cycle will provide a visual indication of the health of the media. If five or more of the bars are still lit even when the filters have just been cleaned, the media should be evaluated to determine if replacement is in order.

BACKWASH DURATION This is the amount of time in seconds that each filter will be flushed once the valves have moved fully into the backwash position. Valid values range from 0 to 1800 seconds (30 minutes). To select an appropriate value, start a backwash operation and if possible, view the water being discharged out of the waste line. When the waste water starts to flow clear, sufficient time has been allowed for the backwash. If waste water cannot be observed, 180 seconds is a reasonable starting value for this parameter. Try experimenting with shorter values until the filter inlet pressure no longer returns to the base pressure after a backwash operation.

INTERFILTER DELAY If the waste water system is not able to handle large flows continuously, the FilterMinder can be configured to delay between backwashing of subsequent filters in a multiple filter system by return to normal filtering of pool water between backwashing of individual filters. The duration of this inter filter dwell time can be set via the Interfilter Delay. Valid values range from 0 to 9999 seconds (6.9 days). Since the heater is not operational during this inter filter dwell time, the delay should be kept to a minimum and for most systems can be left at 0.

VALVE SHIFT DELAY When a backwash operation is initiated, the Valve actuator associated with the filter being backwashed is energized. Water or air starts to flow into the diaphragm actuated valves that must be shifted to accomplish the backwash. Some time is required for the control sections of these valves to fill up before the flow through the filter is reversed for backwash. We call this the Valve Shift Delay. This delay varies depending on the size of the valves used and the supply pressure and type of the control media. Values range from 0 to 180 seconds. A typical value would be 60 seconds for a single 8 inch valve. This value can usually be determined by listening to the sound of the valves. They tend to be rather noisy while shifting positions.

COOL DOWN DELAY Pool heaters rely on the flow of pool water past the heat exchanger to keep temperatures from becoming too great. Thermal safeties are employed to

automatically turn off the heater when the internal temperatures become too high, but use of these safeties results in unnecessary thermal stress on the heat exchanger. The best approach is to turn off the heater in advance of shutting off the water flow and then allowing sufficient time for the heater to cool off before shutting off the water.

FilterMinder takes this latter approach. Values range from 0 to 600 seconds (10 minutes). This same delay can be used to disable chemical feed systems to allow all dispensed chemicals to be flushed into the pool before backwash operations divert flows to the waste line.

SURGE DELAY In many installations, events other than backwash operations can cause momentary fluctuations in the pressure at the inlet to the filter system. It is undesirable to have these fluctuations inadvertently initiate a backwash operation. If a pressure sensor is used, the FilterMinder averages readings from this sensor over a 10 second interval to prevent wild fluctuation of the displayed value. In addition to this averaging, the system can be configured to verify that the inlet pressure remains above the selected backwash trip pressure for an extended period of time before the decision to backwash is made. This period of time is called the **SURGE DELAY** and has values ranging from 0 to 180 seconds.

NUMBER OF FILTERS The FilterMinder can be configured to manage systems containing from 1 to 3 filters.

VALVE SHIFT MODE Most diaphragm actuated valves can be shifted while the circulation pumps are running but many operators prefer to shut the pump off while shifting valves to reduce stresses on the system (and noise). Other operators don't like to cycle the pumps any more than necessary and wish to leave them on while shifting valves. The **VALVE SHIFT MODE** allows the user to configure FilterMinder to do either. If the **TURN PUMP OFF** mode is selected, the pump relay is de-energized each time a valve is moved and remains off for the duration of the **VALVE SHIFT DELAY** before coming back on. If the **LEAVE PUMP ON** mode is selected, the pump relay remains energized all of the time. Regardless of which **VALVE SHIFT MODE** is selected, the heater relay is always de-energized and the system waits for a **COOL DOWN** period before moving any valves at the start of a backwash cycle and the heater relay remains off until all valves have returned to their normal Filter position.

SYSTEM STATUS

This screen allows the user to manipulate the state of the output relays and to see the states of the LOCK/UNLOCK switches. If your system is equipped with a rotary stager valve, the Valve 1 output is used to energize/de-energize the stager valve motor. When energized, you should be able to see the states of the CAM and HOME microswitches change as the motor rotates. Valve 1, Valve 2 and Valve 3 can be opened and closed from this screen. The pump and heater relays can be manipulated from the **PUMP/HEAT CONTROL** screen and are not included here.

FIELD WIRING DETAILS

All field wiring connections to the FilterMinder are made to screw terminals inside the enclosure. Wires should be routed through the two cable glands on the bottom of the enclosure and the clamping nuts should be tightened to 16 in-lbs. to effect a water tight seal around the wires. If possible, run all low voltage wiring through one gland (24VAC power, pressure sensor and remote interface cable, if used) and all high voltage wiring through the other (pump, heat and aux).

POWER

The FilterMinder is supplied with a cube style plug-in transformer that is rated at 120VAC 60 Hz input at 0.50A maximum. The output of this transformer is rated at 24VAC with 50VA maximum. If desired, an alternate supply may be substituted, but the supply must be U.L. Class 2 rated. The output terminals of this transformer should be connected to the two euro style clamping terminal contacts pointed to by arrow 1 in Figure 3 and identified as terminals 7 and 8 on the terminal block. Polarity is not important. If wire other than that supplied with the FilterMinder is used, strip the wire 5/16". Loosen the terminal screw until some resistance is felt indicating that the clamping mechanism is completely open. Install the stripped wire end into the terminal until it stops. The terminal should then be tightened to a torque of 56 in-oz. to secure the wire.

PRESSURE SENSOR

The FilterMinder comes with a differential pressure sensor installed on the bottom of the case. The filter inlet should be plumbed to the port on the left and the filter outlet should be plumbed to the port on the right. This sensor has been pre-wired to the terminals identified by arrow 2 in Figure 3 and marked as Com, Sensor and +5 VDC on the Wiring Label inside the case. If using an external trigger to initiate backwash operations, this sensor should be disconnected and the dry contacts of the external trigger wired between the Sensor and +5 VDC terminals. Tighten these terminals to 56 in-oz. Either an external switch or the pressure sensor can be used, but both cannot be connected at the same time. Attempts to do so will permanently damage the pressure sensor.

PUMP AND HEATER

The relay identified by arrow 3 in Figure 3 is for controlling the pool Heater. The relay identified by arrow 4 is for controlling the main circulation Pump. These relays are energized when the controller wishes to have the attached device running. Select the NO or NC relay contacts as appropriate for your particular installation requirements. For example, when the FilterMinder wishes to have the pool's main circulation pump running, it will energize the Pump relay and an electrical connection will be made between the two bottom screw terminals of this relay socket (see section on RELAY CONTACTS).

VALVE 1, VALVE 2, VALVE 3

The terminals identified by arrow 5 in Figure 3 are for controlling backwash valve actuators. These terminals are in pairs with the left terminal of the pair providing 24 VAC power (always) and the right terminal of the pair connecting this circuit to AC Common when active. A 24 VAC solenoid coil or relay coil can be connected between these two terminals and the solenoid or relay will be activated when the associated red LED under the display is illuminated. A maximum load of 300 MA (7 VA) can be powered from each of these terminal pairs.

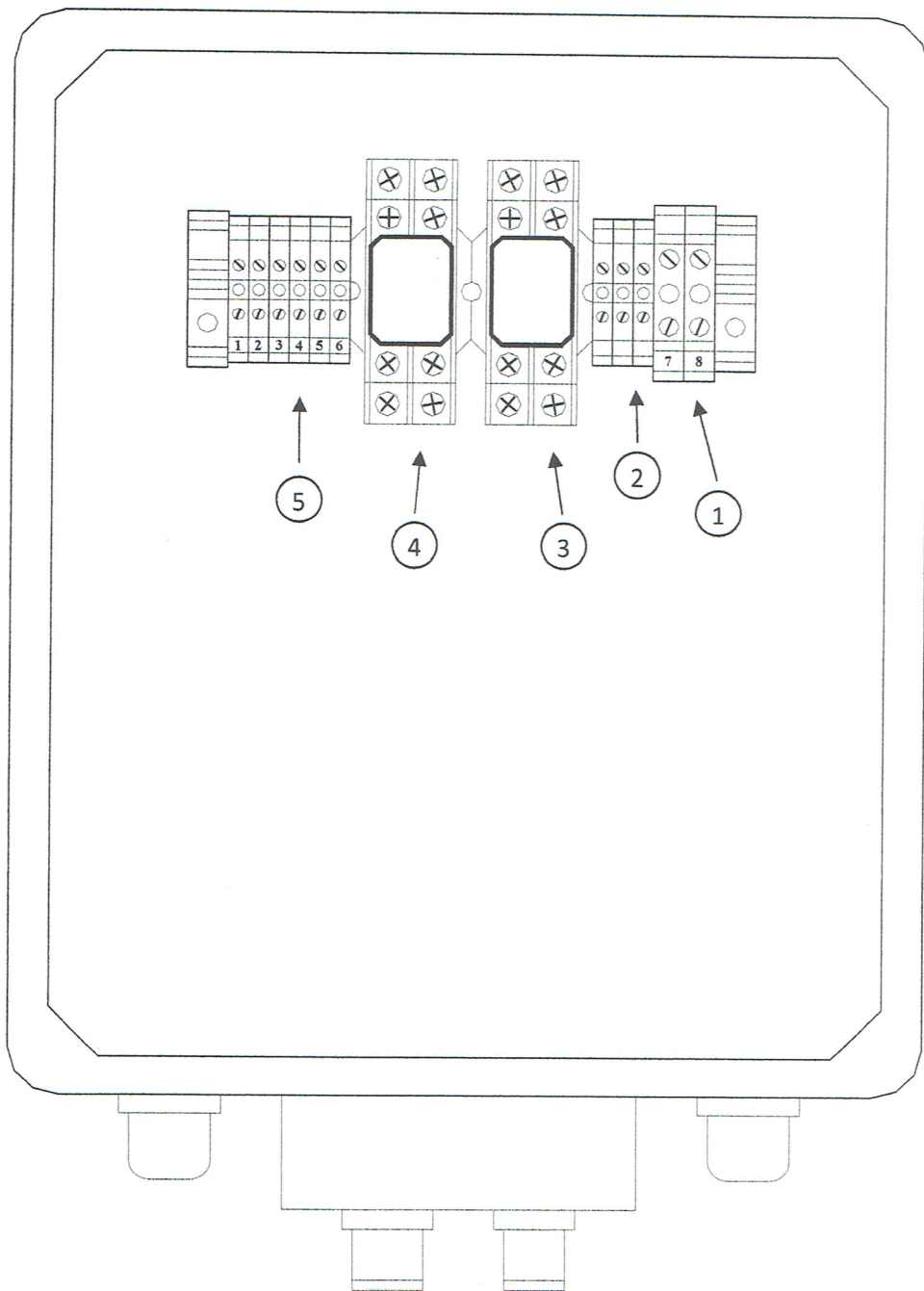

Figure 3

RELAY CONTACTS

Each relay contains two Form C contacts (both NO and NC poles available) rated at 10A 240VAC pure resistive load each contact.

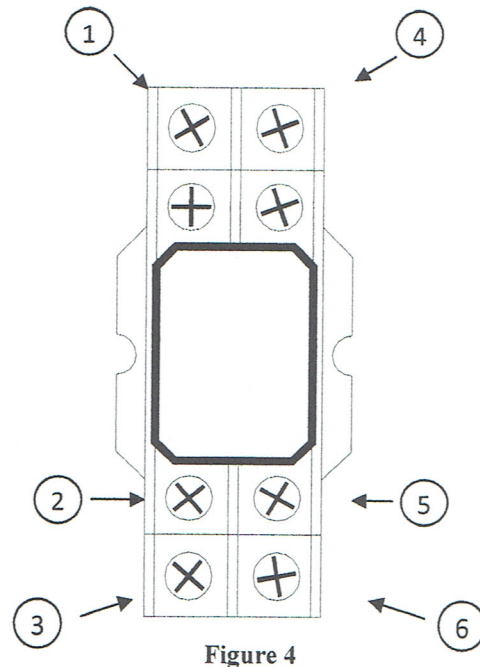

Figure 4

For section A of this relay, the terminal identified as item 1 in figure 4 is the Common contact, the terminal identified as item 2 is the Normally Closed (NC) contact and the terminal identified as item 3 is the Normally Open (NO) contact.

For section B of this relay, the terminal identified as item 4 is the Common contact, the terminal identified as item 5 is the Normally Closed (NC) contact and the terminal identified as item 6 is the Normally Open (NO) contact.

The relays come pre-wired with the two Common terminals (marked 1 and 4 above) connected to each other with a jumper. In this configuration, the relay can be used as a single Normally Closed switch by connecting the load in series with terminals marked 2 and 5 above, or as a single Normally Open switch by connecting the load in series with the terminals marked 3 and 6 above.

As an alternative, this jumper may be removed and a jumper placed from the Common contact of the relay to the terminal marked Hot (terminal 8) on the terminal strip. The relay now will source 24 VAC out of the NC contact when de-energized and out of the NO contact when energized.

These terminals are clamping style connectors. Strip the wire 5/16". Loosen the terminal screw sufficiently to open the clamping mechanism and provide clearance for the wire. Insert the wire until it stops against the back of the terminal. Clamp the wire by tightening the terminal screw to 10 in. lbs.

System Hardware Specifications

Electrical Specifications

Input Power:	Outlet Mounted Transformer Input: 120 VAC 60 Hz 0.50 Watts Max. Output: 24VAC 50VA UL Class 2 rated
Valve Outputs:	24 VAC, 300 MA each output. Power is Sourced continuously from terminals 1, 3 and 5 And returns are sinked to Com when energized
Relay Contacts:	10A 250/120 VAC or 30 VDC resistive, 7A 250/120 VAC or 30 VDC general purpose, 1/6 HP at 120 VAC or 1/3 HP at 240 VAC Normally Open and Normally Closed contacts are both available.
Pressure Sensors:	0 – 50 PSI Differential 100 PSI maximum pressure.

Environmental Specifications

Temperature:	0 to 50 Degrees C (32 to 122 Degrees F) Operating.
Humidity:	0% to 90% Relative Humidity (non-condensing)
Enclosure Sealing:	NEMA 4 (Hose Down) with access door closed.