

# Vapor Tight High Bay

## Applications

- Food Processing Facilities
- Refrigerated Storage
- Parking Garages
- Breweries and Bottling Facilities
- Livestock Facilities

## Certifications

- Tested/Certified by NSF International
- UL Wet Location
- NEMA 4X
- IP66/IP67
- ROHS



## Features

- Designed for tough environments
- Weatherproof enclosures
- T5 or T8
- Easy to clean and service
- Variety of lamp combinations (3,4,5,6)
- Impact resistant lenses
- Stainless steel hardware
- Simple mounting system—no holes to drill!



Proudly made in the U.S.A



## Mounting Options

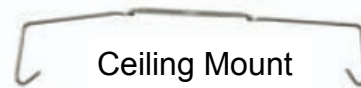

Cable Mount

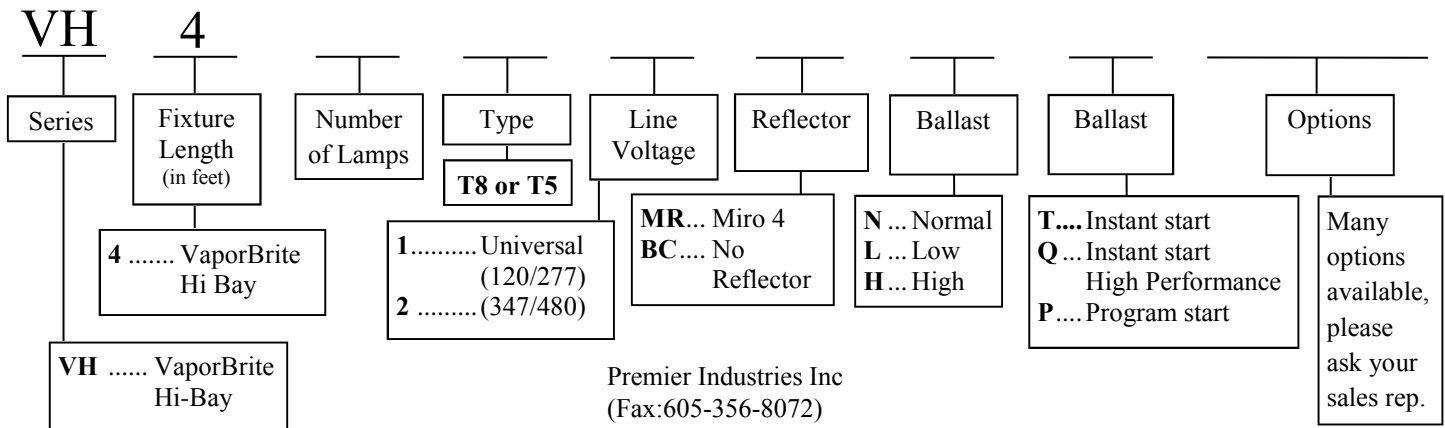

Wayne:712-251-7186 Korey:712-223-7859 Sheena:712-212-1432

Email: wayne@premierindinc.com sales@premierindinc.com; sheena@premierindinc.com