

Owner's Manual

**AMC**

360

460

560

Snell

## SPECIFICATIONS

## AMC360

Frequency Response ( $\pm 3\text{dB}$ )	65–20,000Hz
Recommended Amplifier Power	10–100 watts
Nominal Impedance	8 ohms
Sensitivity [1 watt (2.83v) at 1m]	90dB
Tweeter	1" (25mm) soft dome
Bass Unit	5 <sup>1</sup> / <sub>4</sub> " (135mm) copolymer
Crossover Frequency	3500Hz
External Dimensions (HxW)	9 <sup>1</sup> / <sub>2</sub> x 6 <sup>3</sup> / <sub>4</sub> " (241 x 171mm)
Mounting Hole Cutout (HxW)	8 <sup>3</sup> / <sub>4</sub> x 5 <sup>3</sup> / <sub>4</sub> " (223 x 146mm)
Mounting Depth (from surface)	2 <sup>5</sup> / <sub>8</sub> " (67mm)
Shipping Weight	9 lbs. (4Kg)

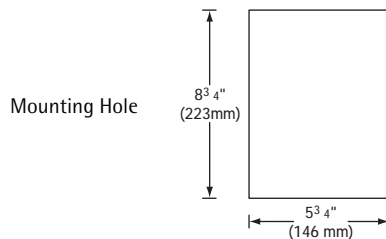
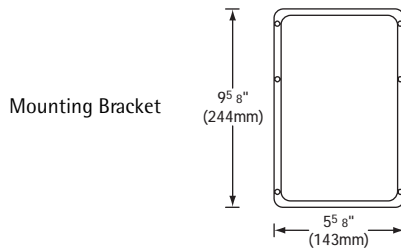
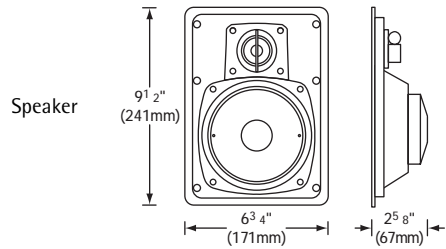

**AMC460****AMC560**

57–20,000Hz

48–20,000Hz

10–125 watts

10–150 watts

8 ohms

8 ohms

89dB

89dB

1" (25mm) soft dome

1" (25mm) soft dome

6<sup>1</sup>/<sub>2</sub>" (165mm) copolymer

8" (200mm) copolymer

3400Hz

3200Hz

10<sup>9</sup>/<sub>16</sub> x 7<sup>3</sup>/<sub>4</sub>" (268 x 197mm)12<sup>3</sup>/<sub>8</sub> x 9<sup>9</sup>/<sub>16</sub>" (315 x 243mm)9<sup>7</sup>/<sub>8</sub> x 7<sup>1</sup>/<sub>8</sub>" (251 x 181mm)11<sup>7</sup>/<sub>16</sub> x 8<sup>1</sup>/<sub>2</sub>" (290 x 216mm)3<sup>1</sup>/<sub>8</sub>" (79mm)3<sup>5</sup>/<sub>8</sub>" (92mm)

11 lbs. (5Kg)

13 lbs. (6Kg)

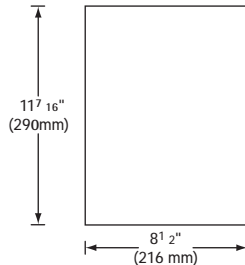
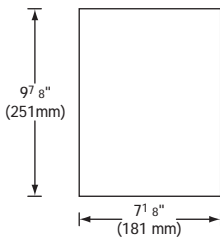
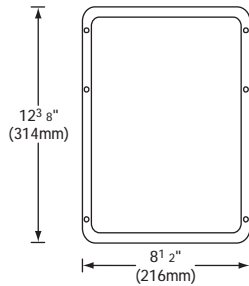
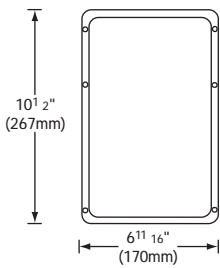
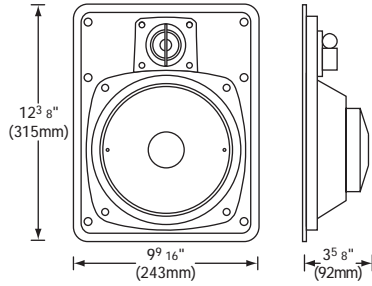
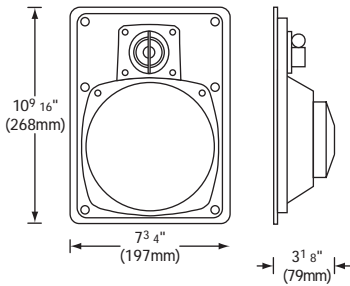

## INTRODUCTION

---

The AMC 360/460/560 in-wall speakers are designed to be as accurate, clean and musical as our free-standing speakers. The unobtrusive, flush-mount design makes them ideal for installation in walls or ceilings of rooms where space or decor make conventional speakers undesirable or inappropriate. They can also be used for front and/or rear channels in a home theater system.

The front surface has a matte white finish. The speaker can be installed as is, or can be painted to match the room environment by using the supplied painting mask. The epoxy-painted, galvanized steel speaker grille is removable.

The smooth, detailed sound of the AMC in-wall speakers comes from two highly refined driver elements: a powerful, long-excursion copolymer bass unit and our 1-inch (25mm) soft dome tweeter. The silk-like fabric dome delivers a remarkably accurate response for outstanding clarity and articulation. The tweeter and bass unit are mounted close together in a point-source configuration for excellent imaging and extremely broad, uniform dispersion. This is important, because wide dispersion gives you the flexibility to install the speakers where they look the best (high on the walls, for example), yet still project a smooth, natural sound throughout the listening area.

Complex, high order crossovers ensure seamless integration of the woofer and tweeter and a perfectly balanced character. In production, Snell's unique hand-tuning gives an incredible  $\pm 1$  dB match to the Master Reference. The AMC in-wall speakers are perfect for any application – main speakers, surround use or background music.

## INSTALLATION INSTRUCTIONS

---

**NOTE:** This manual assumes the installer possesses skill in the proper use of hand and power tools, a knowledge of local building and fire codes and a familiarity with the environment behind the wall or ceiling in which the speakers will be installed.

Examine the contents of the package and verify that it contains the following:

<u>Quantity</u>	<u>Description</u>
2	AMC Series Speakers
2	Mounting Bracket
2	Barrier Cloth
2	Painting Mask
2	Metal Grille
1	Template
1	Owner's Manual/Installation Instructions
1	Hardware Package*

Hardware package\* contents:

12	8-32 x 2" screw
----	-----------------

## WHERE TO PLACE YOUR SPEAKER SYSTEMS

### Effects Of The Wall

The wall or ceiling into which the AMC in-wall speaker is placed becomes its acoustical enclosure. A large part of the system's acoustical performance is dependent on that enclosure. Generally, large volumes will ensure full bass extension. Whenever possible, avoid placing the speaker at either end of along column such as that created between wall studs, the footer, and the header. Placement at the ends of such a tunnel will create a "closed-end tuned pipe" that can greatly reduce the bass. Rather than having hard surfaces behind the speakers that will cause reflections, lightly fill the volume behind the system with fiberglass or other sound-absorptive material.

- ▶ Ensure adequate rear volume (0.5 cubic feet or better).
- ▶ Avoid placing the system at the extreme end of the chamber formed by 2x4 framing.
- ▶ Fill the volume behind the loudspeaker with acoustically absorptive material.

### Stereo Image

The distance between the speakers determines the width of the stereo image. If the speakers are placed too close together, the image will be too narrow; too far apart and the blend will suffer, creating a "hole in the middle."

We recommend an angular separation between 45 degrees and 60 degrees (when viewed from above). This is equivalent to a separation between the speakers that is about 75% to 100% of the distance from the listener to either of the speakers.

Creation of "virtual images" (sounds between the speakers) requires precise placement. The distance from the left and right speaker to the listener location should all be as equal as possible. Use a tape measure when selecting installation locations to check the loudspeaker-to-listener distance. Ideally, the front channel speakers should be installed at the same height as the ears of a seated listener. Try to keep the front channel tweeters within two vertical feet of that height. When properly placed, your speakers will create a continuum of virtual images from left to right, with a convincing illusion of sound outside, in front of, and behind the speaker systems.

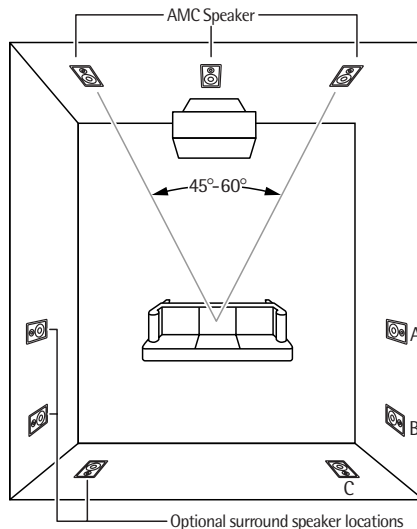

### Using As a Surround Speaker

The compact size and neutral tonal quality of the AMC speakers makes them perfect for the surround channels of a home theater system. The best locations for speakers used for surround sound are directly to the side of the listeners (A) or somewhat behind the listeners (B). If these locations are not practical, then the rear wall (C) may be use, or even ceiling mounting is acceptable. Surround speakers should be placed above the level of your ears when you are standing. Never locate a surround speaker so close to a listener that attention will be drawn to them.

## PAINTING THE SPEAKERS

---

If you intend to paint the speakers, it's best to do so before installation.

1. Remove the speaker grille. Carefully pry at each corner with an awl or small screwdriver.

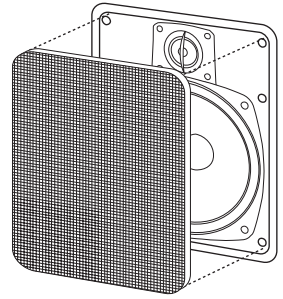

2. Place a strip of wide masking tape over each of the holes in the paint shield. Place the paint shield on the front of the speaker. Press on the tape to hold to seat the paint shield in position on the front of the speaker baffle.

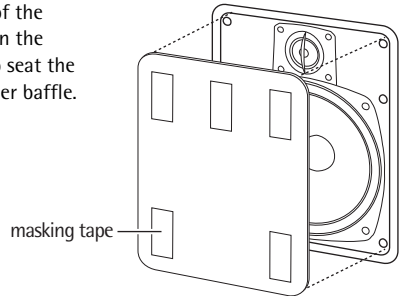

3. After painting, carefully remove the paint shield.

4. When painting the grilles, be certain that the paint does not fill the perforated holes in the metal. If using spray paint, use two thin coats.

If using house paint or other canned paint, thin the paint to avoid filling the holes.

Be sure to use appropriate exterior paint for outdoor applications.

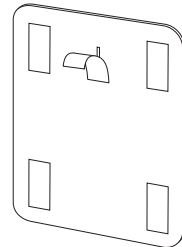

## PREPARING FOR INSTALLATION

---

Map out the wiring paths from the speakers to the amplifier. We recommend 16-gauge wire for runs up to 25 feet, and 14-gauge or thicker for longer runs. Be sure the speaker wire does not rest or rub against any sharp or pointed objects.

One solution for running wires is to drop wires from the mounting location to an available wall plate near the floor. Your system wires can run around the perimeter of the room at floor level, into the wall plate and then invisibly up to the speaker.

The speakers should be mounted on a flat surface to form a good seal between the speaker flange and the mounting surface.

Each speaker is 8 ohms nominal. When connecting more than two speakers per amplifier channel, you should use series/parallel wiring or line transformers. In all cases, make certain that the total impedance does not fall below the amplifier's minimum rating. If you are not sure, contact your Snell Acoustics dealer.

## YOU WILL NEED

1. A utility knife, electric jigsaw or other means of cutting a hole in the mounting surface.
2. Phillips and flat-blade screwdrivers.
3. A wire cutter or stripper for preparing the speaker wires.
4. An awl or small screwdriver to remove the speaker grille.

With the hardware supplied, the speaker can be installed in existing walls and ceilings from 3/8" (9.5mm) to 1 1/2" (38mm) thick. For thinner walls, you will need to use spacers (not provided) for the mounting bracket. In walls greater than 1 1/2" (38mm) thick, you will need longer screws.

## Installation

1. Using the *inside edge* of the template, mark the outline of the installation hole and cut it out.
2. Run wire from the amplifier to the cutout. Allow an extra foot of wire at the cutout. Strip 1/2" (12mm) off wire, and tightly twist the wire strands.
3. Remove speaker grille. Carefully pry each corner with an awl or small screwdriver.
4. Prepare the speaker/bracket assembly for installation as shown. For new construction, an optional bracket (Model NCB5 for the 360, NCB6 for the 460, Model NCB8 for the 560) is available from your Snell Acoustics dealer.

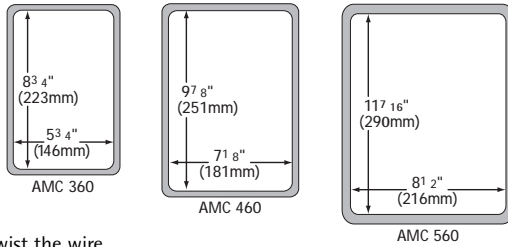

**WARNING:** To prevent electrical shock hazard, always switch off the amplifier or receiver when making connections to the speaker.

**IMPORTANT:** Typically, one side of the wire is smooth. Connect this side to the - (black) speaker terminal. The other side has a rib or stripe. Connect this to the + (red) speaker terminal. Connect wire at the amplifier in the same way. Failure to do so will result in degraded sound.

6. Install speaker according to diagram below.

**IMPORTANT:** Do not overtighten screws. Doing so will break the frame and/or make it impossible to insert the grille.

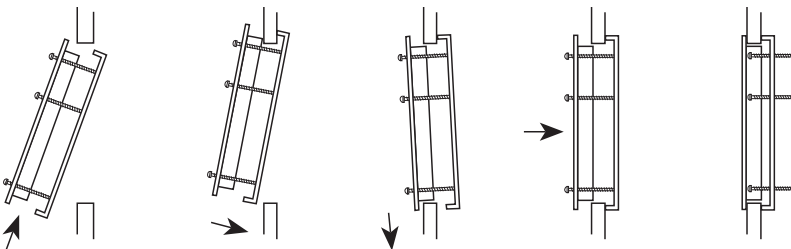
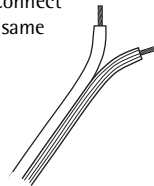
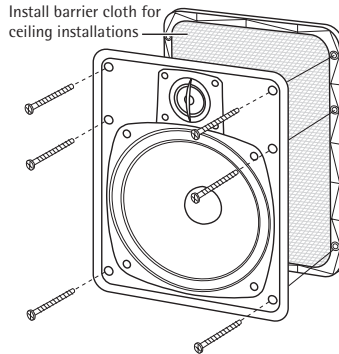

## LISTENING LEVELS AND POWER HANDLING

---

The power recommendation for the system assumes you will operate the amplifier in a way that will not produce distortion. All speakers can be damaged by even a modest amplifier if it is producing distortion. If you hear a gritty noise or other signs of strain, turn down the volume. Prolonged or repeated operation of your speakers with a distorted signal can cause damage that is not covered by the warranty. It is especially important that you do not overdrive the bass capability of smaller speakers. Watch for noises, such as pops, caused by the music's bass line. Use of the loudness control and/or full bass boost at louder volumes is likely to overdrive the woofer. Use such controls sparingly.

## LIMITED WARRANTY

---

For five years from the date of purchase, Snell Acoustics will repair for the original owner any defect in materials or workmanship that occurs in normal use of the speaker system, without charge for parts and labor.

Your responsibilities are to use the product according to the instructions supplied, to provide safe and secure transportation to an authorized Snell Acoustics service representative, and to present proof of purchase from an authorized Snell dealer in the form of your sales slip when requesting service.

Excluded from this warranty is damage that results from abuse, misuse, accidents, shipping, repairs, or modifications by anyone other than an authorized Snell Acoustics service representative. This warranty is void if the serial number has been removed or defaced.

This warranty gives you specific legal rights, and you may also have other rights that vary from state to state.

### If Service Seems Necessary

Contact the dealer from whom you purchased the speaker system. If that is not possible, call us at 978-538-6262, or write to:

Snell Acoustics  
300 Jubilee Drive, POB 3717  
Peabody, MA 01961-3717

We will promptly advise you of what action to take. If it is necessary to return your speaker system to the factory, please ship it prepaid in the original factory packaging. Please note that Snell Acoustics will not be held liable for shipping damage due to improper packaging. After it has been repaired, we will return it freight prepaid in the U.S. or Canada.

# Snell

300 Jubilee Drive, POB 3717  
Peabody, MA 01961-3717  
phone: 978-538-6262  
fax: 978-538-6266  
email: [info@snellacoustics.com](mailto:info@snellacoustics.com)  
[www.snellacoustics.com](http://www.snellacoustics.com)