

## Sivoia® QS

wiring and  
programming  
guide

# Sivoia® QS Wiring and Programming Guide

---

*Sivoia* QS Drives are available for control of Draperies, Roller Shades and Tensioned Shades. *Sivoia* QS Shades and Draperies can be controlled as part of a QS System, incorporating *GRAFIK Eye* QS lighting controls, or as a *Shades/Draperies only* System, without lighting controls.

*Sivoia* QS Drives and Keypads are powered from a 24 V<sub>DC</sub> power supply. All drives, power supplies, keypads and other control devices are linked together with the same four wire communication link. This link provides 24 V<sub>DC</sub> to all components.

The Shades/Draperies can also be operated via an infrared Hand-Held Remote Control. These can be used in either a *GRAFIK Eye* QS Integrated System or *Sivoia* QS Standalone System. The IR remotes can move the Shade or Drapery to the open and close limit. They also provide the additional functions of storing and recalling a favorite preset, and setting open and close limits remotely.

---

Wiring

QS link power supply .....	3
Smart panel - one shade per output .....	4
Smart panel - two shades per output .....	5
Smart panel - three shades per output .....	6
GRAFIK Eye QS integration .....	7
Wire length chart .....	8

Setting limits

From the drive .....	9
From a keypad .....	12

Verifying communication

From the drive .....	10
From the smart panel .....	10

Programming

Assigning shades/draperies to keypads .....	11
Storing presets from a keypad .....	13
Individual level adjust .....	14

Restoring defaults

Drive .....	15
Keypad .....	16

Troubleshooting

Troubleshooting Chart .....	17
-----------------------------	----

# 1

## System Wiring Overview: QS Link Power Supply

**Example:** Powering one shade / drapery drive unit  
(max of one shade / drapery drive unit per output of a power supply)

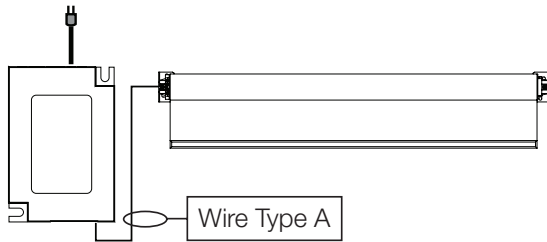

**Example:** Powering keypads

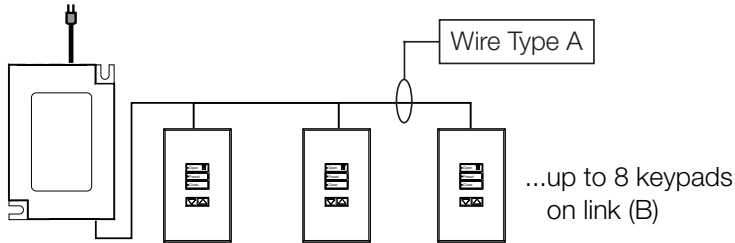

**Example:** Connecting to a *GRAFIK Eye*® QS (**Note:** *GRAFIK Eye* QS powered from line voltage)

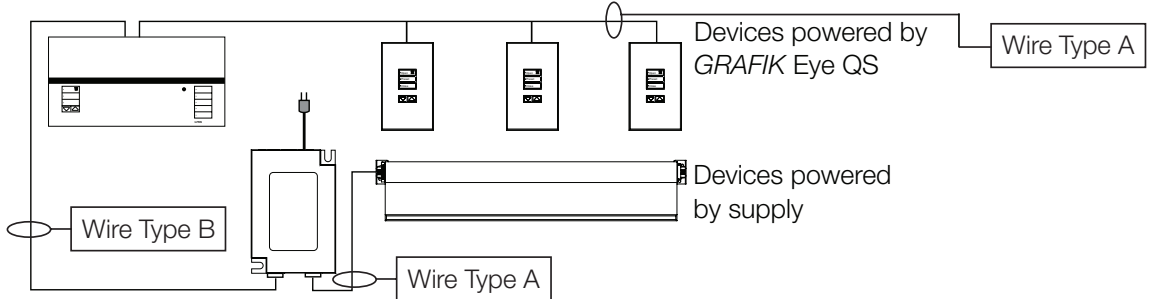

**Example:** Connecting to a *GRAFIK Eye* QS (**Note:** *GRAFIK Eye* QS powered from line voltage)

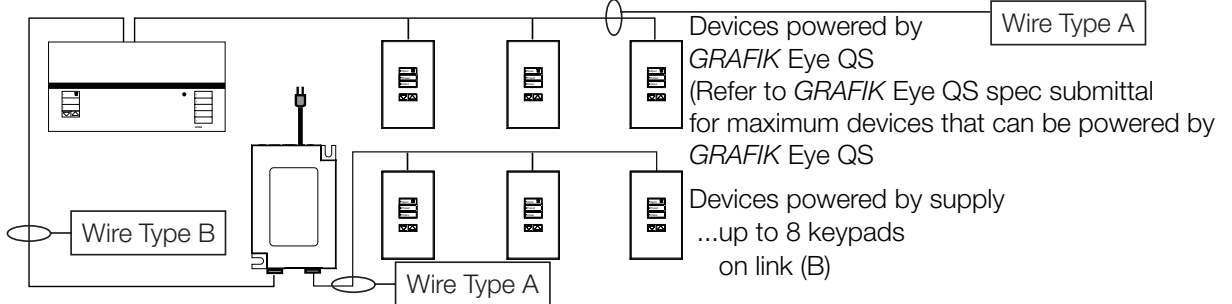

### Wiring Type Key

**Type A** Power and communication link (4 conductor)  
Provides power and communication to QS shades or keypads  
12-26 AWG (4-0.15 mm<sup>2</sup>) standard, twisted/shielded

**Type B** Communication link (3 conductor)  
Communications used to connect power supplies to each other or to *GRAFIK Eye* QS  
12-26 AWG (4-0.15 mm<sup>2</sup>) standard, twisted/shielded

Refer to wiring guide on pg 8 for wire gauge based on distance.

**Note:** Secondary wiring must be of type CL2, CL2P, CL2R, CL2X or other cable with equivalent or better electrical, mechanical, and flammability ratings in accordance with local and national electric code.

# 2

## Sivoia QS System Wiring: Smart Panel power supply, single shade per output

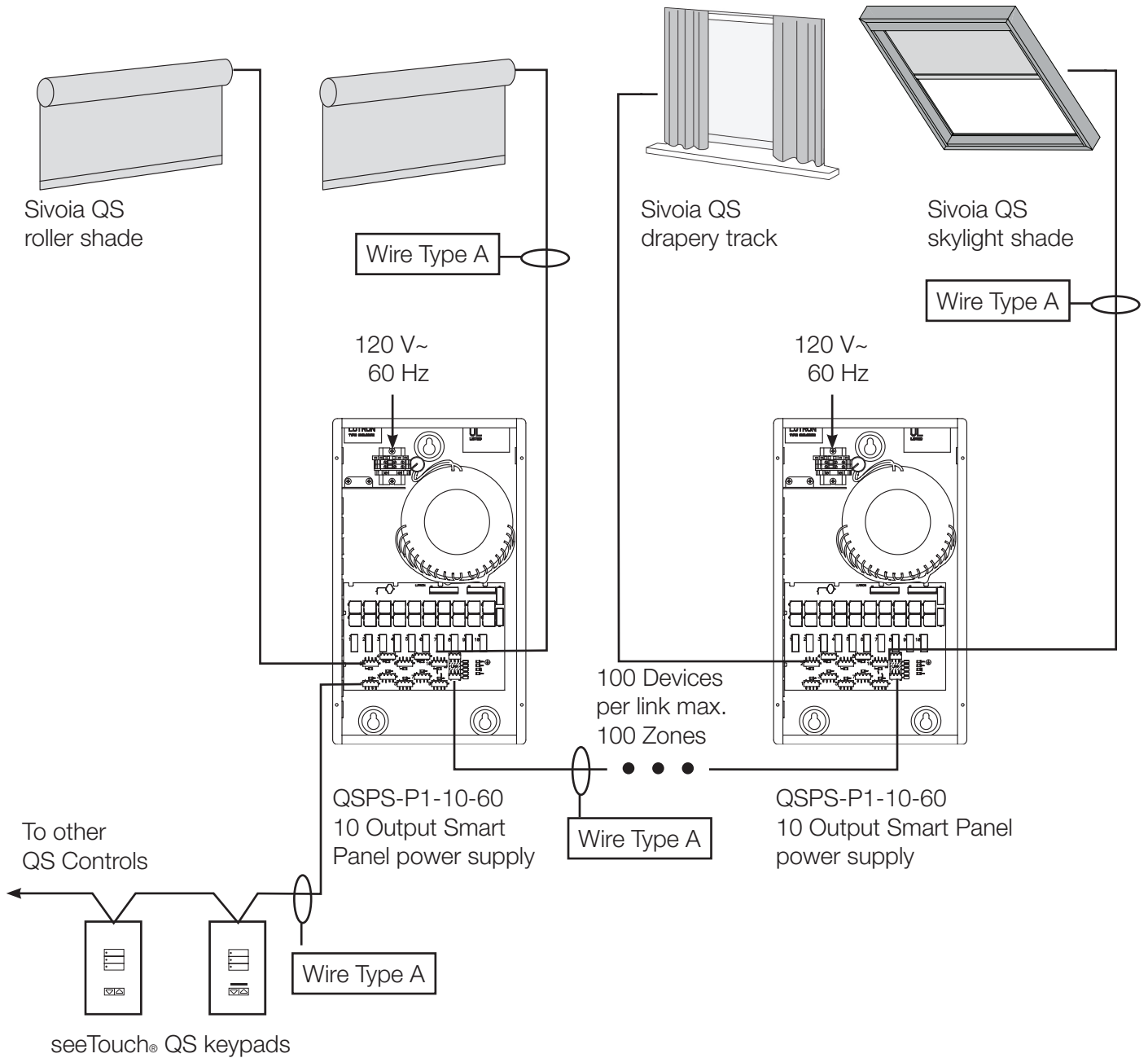

### Wiring Type Key

#### Type A

Communications Link: 4 Conductor (twisted and shielded), listed for application  
 Refer to wiring guide on pg. 8 for wire gauge based on distance  
 Maximum comm. link: – Up to 2000 ft (600 m) connecting all QSPS-P1-10-60 panels

**Note:** Secondary wiring must be of type CL2, CL2P, CL2R, CL2X or other cable with equivalent or better electrical, mechanical, and flammability ratings in accordance with local and national electric code.

# 3

## Sivoia QS System Wiring: Smart Panel power supply, two shades per output\*

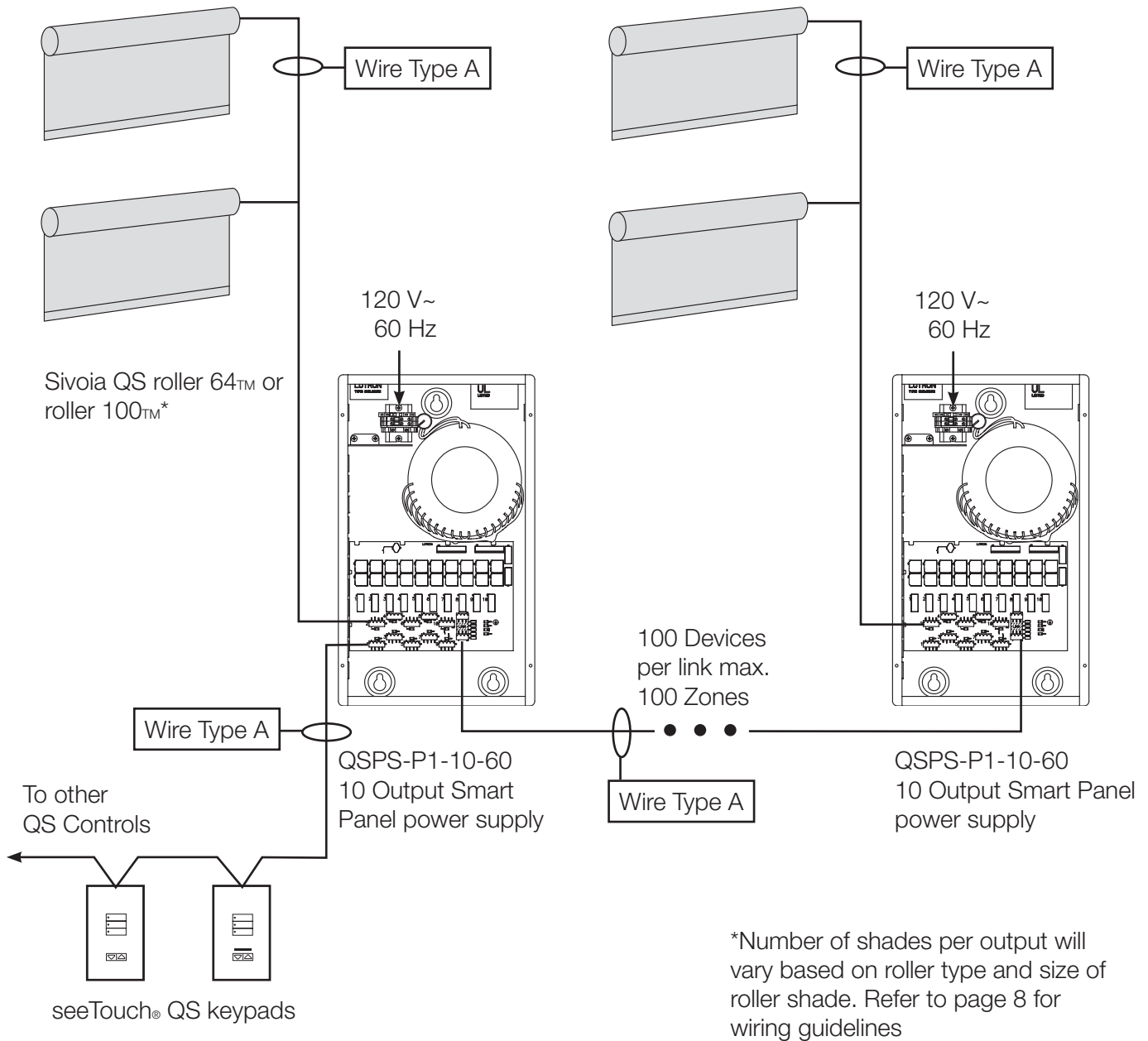

### Wiring Type Key

#### Type A

Communications Link: 4 Conductor (twisted and shielded), listed for application  
 Refer to wiring guide on pg. 8 for wire gauge based on distance  
 Maximum comm. link: – Up to 2000 ft (600 m)  
 connecting all QSPS-P1-10-60 panels

**Note:** Secondary wiring must be of type CL2, CL2P, CL2R, CL2X or other cable with equivalent or better electrical, mechanical, and flammability ratings in accordance with local and national electric code.

# 4

## Sivoia QS System Wiring: Smart Panel power supply, three shades per output\*

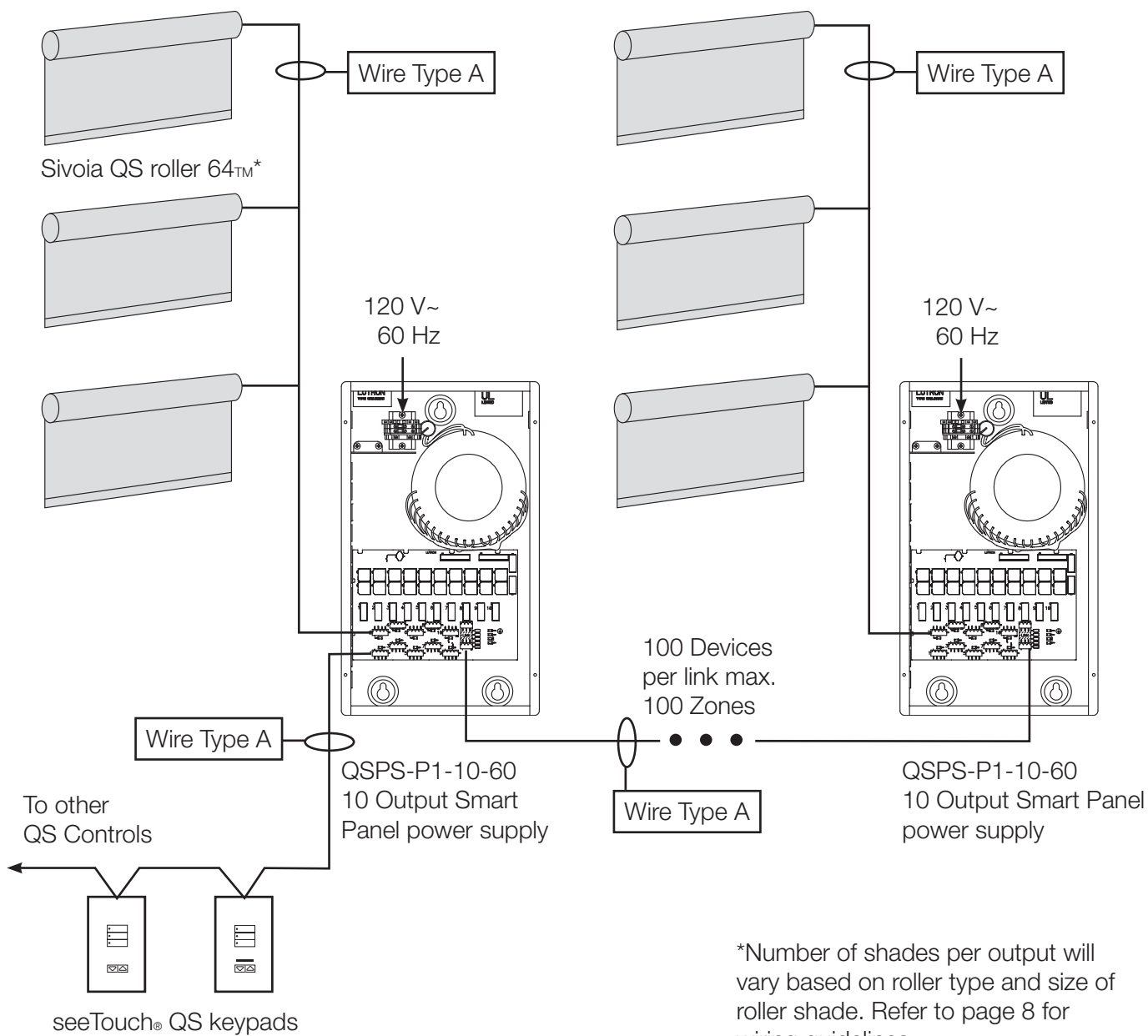

### Wiring Type Key

#### Type A

Communications Link: 4 Conductor (twisted and shielded), listed for application  
 Refer to wiring guide on pg. 8 for wire gauge based on distance  
 Maximum comm. link: – Up to 2000 ft (600 m)  
 connecting all QSPS-P1-10-60 panels

**Note:** Secondary wiring must be of type CL2, CL2P, CL2R, CL2X or other cable with equivalent or better electrical, mechanical, and flammability ratings in accordance with local and national electric code.

# 5

## Sivoia QS with GRAFIK Eye® QS System Wiring: Smart Panel power supply, single shade per output\*

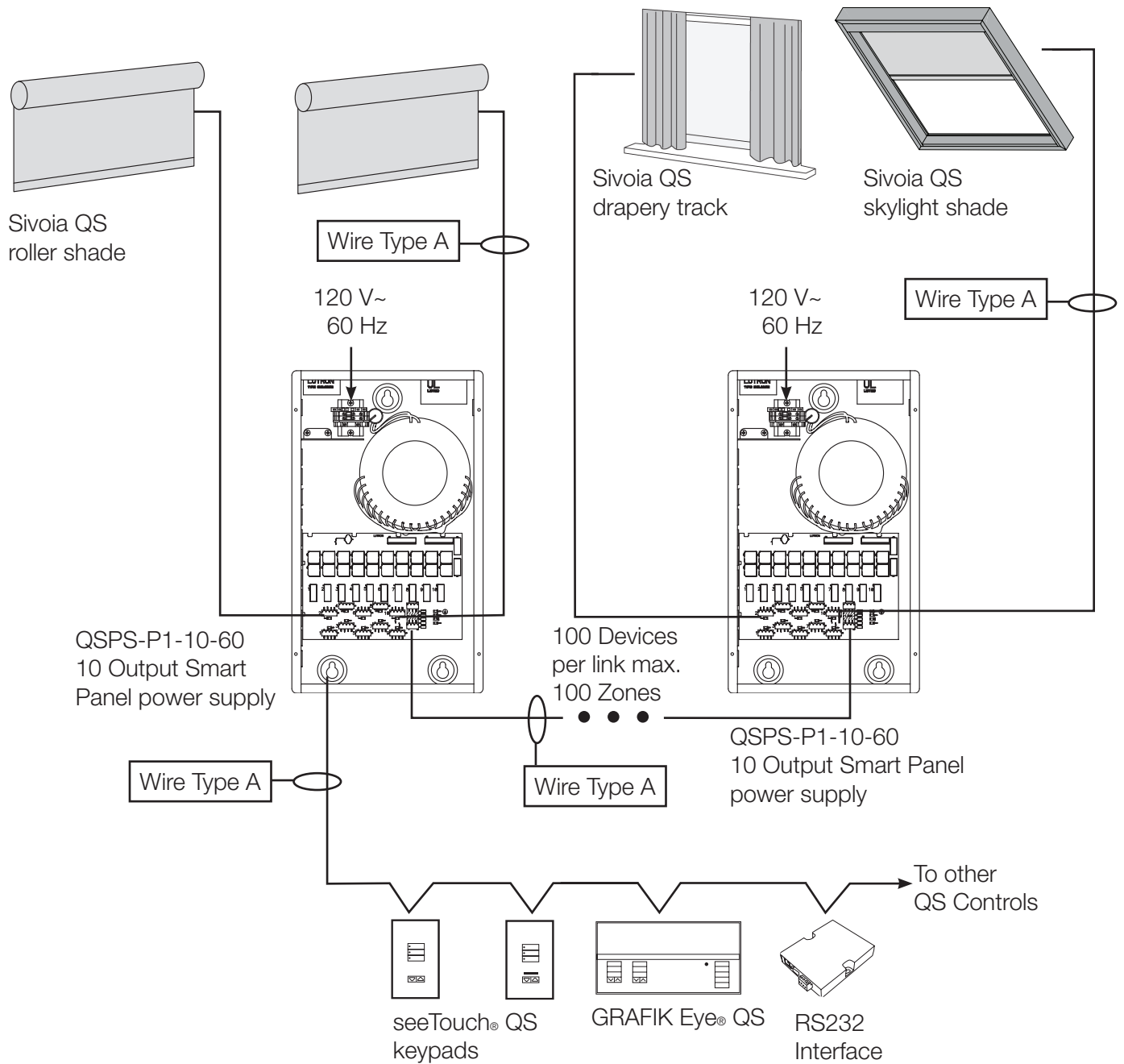

### Wiring Type Key

#### Type A

Communications Link: 4 Conductor (twisted and shielded), listed for application  
 Refer to wiring guide on pg. 8 for wire gauge based on distance  
 Maximum comm. link: – Up to 2000 ft (600 m)  
 connecting all QSPS-P1-10-60 panels

**Note:** Secondary wiring must be of type CL2, CL2P, CL2R, CL2X or other cable with equivalent or better electrical, mechanical, and flammability ratings in accordance with local and national electric code.



## Wire Length Chart

### QS Smart Panel Power Supply Wiring Guide

#### Link Rules

- Maximum of 100 devices (such as GRAFIK Eye® QS, seeTouch® QS keypad, smart panel power supply, or Sivoia® QS shade/drapery drive unit)
- Maximum of 100 zones (such as Sivoia QS shade/drapery drive unit, or a lighting zone on a GRAFIK Eye QS)
- Maximum 2000 ft. (600 m) of cable connecting all smart panel power supplies
- Maximum 2000 ft. (600 m) of cable to devices wired from each smart panel power supply
- Only use cable with at least one twisted/shielded pair for communications

Use this chart to determine the number of shades and/or controls that can be run from one output on the Sivoia QS Smart Panel power supply, depending on the size of the shade. Then, verify the maximum cable length for the output configuration, based on the wire gauge that will be used.

Maximum devices per one output		Maximum distance per one output based on wire gauge		
Shades + Controls		12 AWG 4 mm <sup>2</sup> QSH-CBL-L-500 QSH-CBLP-L-500	16 AWG 1.5 mm <sup>2</sup> QSH-CBL-M-500 QSH-CBLP-M-500	18 AWG 1 mm <sup>2</sup> GRX-CBL-346S-500
None	Up to 8 seeTouch QS keypads	1200 ft (350 m)	500 ft (150 m)	300 ft (90 m)
1 Sivoia QS shade/drapery drive unit	Up to 1 seeTouch QS keypad	500 ft (150 m)	200 ft (60 m)	125 ft (35 m)
2 Sivoia QS roller 64, ≤ 30 sq ft (2.75 sq m) each	None	200 ft (60 m)	75 ft (20 m)	50 ft (15 m)
3 Sivoia QS roller 64, ≤ 20 sq ft (1.80 sq m) each	None	200 ft (60 m)	75 ft (20 m)	50 ft (15 m)
2 Sivoia QS roller 100, ≤ 50 sq ft (4.6 sq m) each	None	200 ft (60 m)	75 ft (20 m)	50 ft (15 m)

### QS Link Power Supply Wiring Guide

#### Link Rules

- Only use cable with at least one twisted/shielded pair for communications
- Total length of power supply link (A) wire plus device link (B) wire in entire system must be less than 2000 ft. (600 m)

Use this chart to determine the number of shades and/or controls that can be run from one QS Link power supply. Then, verify the maximum cable length for the output configuration, based on the wire gauge that will be used.

Maximum devices from one QS Link power supply		Total wire length based on wire gauge		
Shades + Controls		12 AWG 4 mm <sup>2</sup> QSH-CBL-L-500 QSH-CBLP-L-500	16 AWG 1.5 mm <sup>2</sup> QSH-CBL-M-500 QSH-CBLP-M-500	18 AWG 1 mm <sup>2</sup> GRX-CBL-346S-500
None	Up to 8 seeTouch QS keypads	1200 ft (350 m)	500 ft (150 m)	300 ft (90 m)
1 Sivoia QS shade*/drapery drive unit	Up to 1 seeTouch QS keypad	250 ft (75 m)	100 ft (30 m)	50 ft (15 m)

**Note:** Secondary wiring must be of type CL2, CL2P, CL2R, CL2X or other cable with equivalent or better electrical, mechanical, and flammability ratings in accordance with local and national electric code.

\* 2 seeTouch QS keypads may be exchanged for 1 control interface (QSE-CI-NWK-E)

# 7

## Setting Limits From the Drive

The open and close limits define the travel range of the shade or drapery. Limits can be set at the Drive, or from a keypad or an IR Remote previously assigned to that Drive. It is recommended that limits be set initially at the Drive.

### Setting Open Limit

**7.1** Tap Open Limit button. Green LED will turn on.

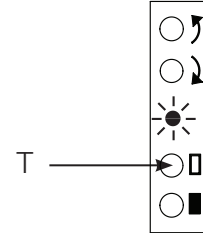

**7.2** Move the Shade or Drapery to desired Open Limit by pressing arrow buttons.

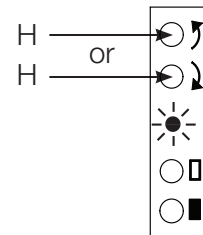

**7.3** Press and hold the Open Limit button until the Green LED flashes. Open Limit is stored.

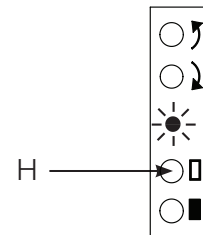

### Setting Close Limit

**7.4** Tap the Close Limit button. The Green LED will turn on.

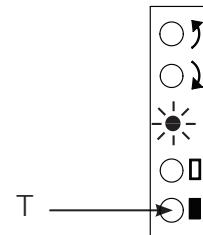

**7.5** Move the Shade or Drapery to desired Close Limit by pressing arrow buttons.

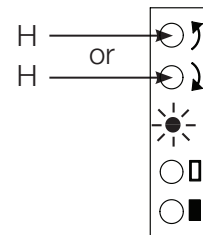

**7.6** Press and hold the Close Limit button until the Green LED flashes. Close Limit is stored.

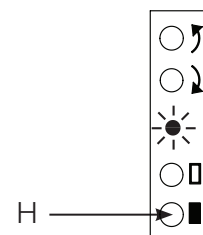

# 8

## Verify Communication

### From a Drive:

8.1

Press and hold Close (■) for 5 seconds,

8.2

Tap CCW (↶) to enter Link Diagnostics mode  
-All shades/draperies will wiggle\*

8.3

Press and hold Close (■) to exit Link Diagnostics Mode.

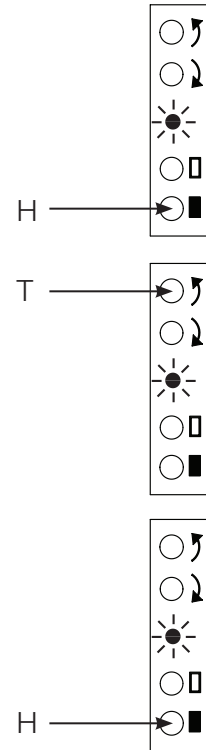

### From the Sivoia QS Smart Panel:

8.4

Tap Open, hold Open 5 seconds., tap Open, hold Open 5 seconds.  
- All shades/draperies will wiggle\*

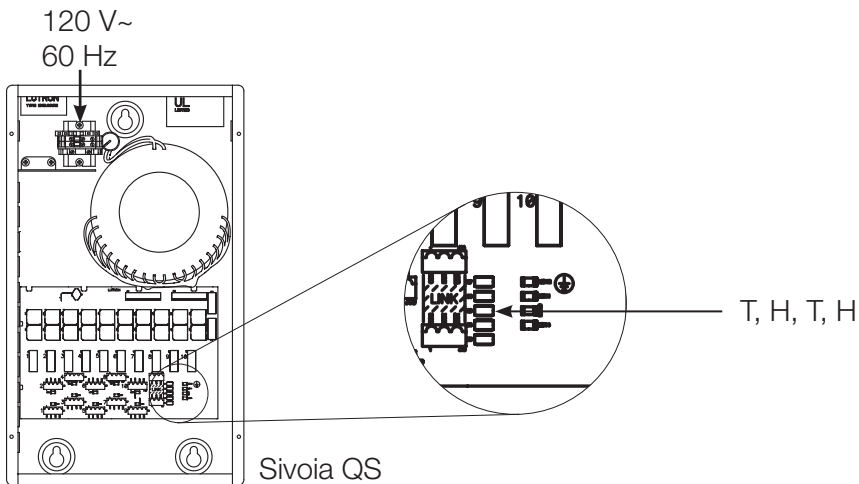

8.5

Press and hold Open 5 sec. to exit Link Diagnostics mode

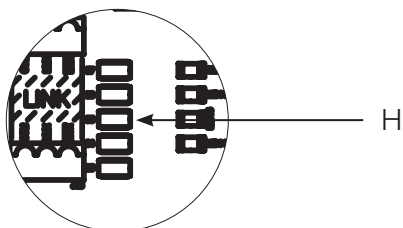

(\*) If any shade/drapery is not wiggling, check the wiring

# 9

## Assigning Shades/Draperies to Keypads

### 9.1

Press and hold Open and Close simultaneously for 5 seconds  
-Shades/draperies that are assigned will move to close (down)  
-Shades/draperies that are unassigned will move to open (up)

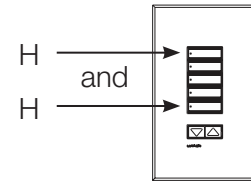

### 9.2

Tapping Open jogs “forward, Close jogs “backward”  
through the shades/draperies

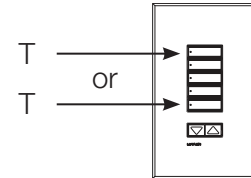

### 9.3

Tap the Lower (▽) to assign or Raise (△) to  
unassign a shade/drapery

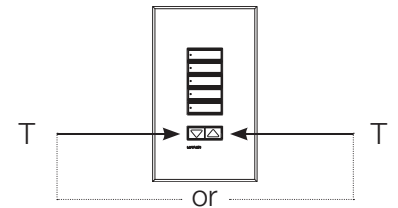

### 9.4

Press and hold Open and Close simultaneously  
for 5 seconds to exit

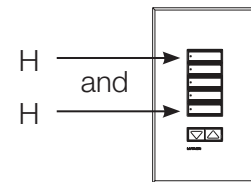

# 10 Setting Limits From a Keypad

**10.1** Press and hold Open and Raise (△) simultaneously for 5 seconds

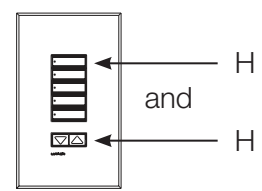

**10.2** Tapping Open jogs “forward, Close jogs “backward” through the assigned shades/draperies

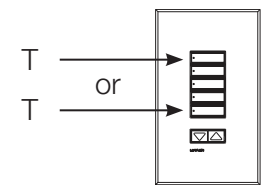

**10.3** Use Raise (△) and Lower (▽) to adjust shade/drapery position

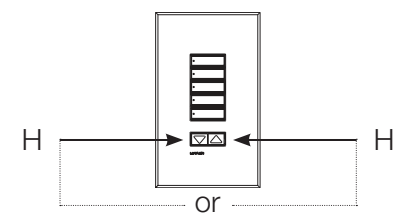

**10.4** Press and hold Open for 5 seconds to store the open limit or Close for 5 seconds to store the close limit

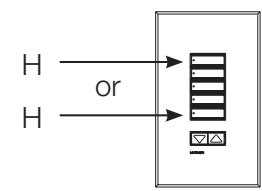

**10.5** Press and hold Open and Raise (△) simultaneously for 5 seconds to exit

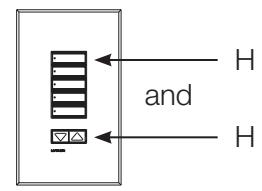

# 11 Storing Presets from a Keypad

11.1 Adjust the shade/drapery to the desired position using raise or lower buttons.

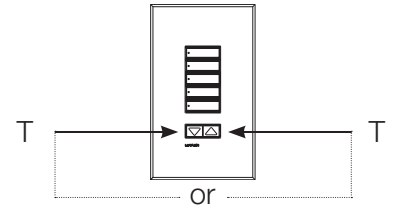

11.2 Store the current position of the shade/drapery by pressing and holding the desired Preset button for 5 seconds

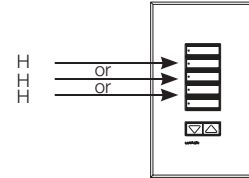

# 12 Individual Level Adjust

**12.1** Press and hold Open and Close simultaneously for 5 seconds  
 -Shades/draperies that are assigned will move to close (down)  
 -Shades/draperies that are unassigned will move to open (up)

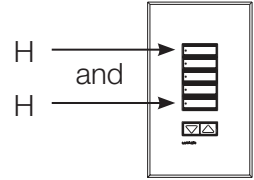

**12.2** Tapping Open jogs “forward, Close jogs “backward” through the assigned shades/draperies

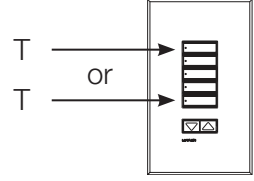

**12.3** Use Raise (△) and Lower (▽) to adjust shade/drapery position

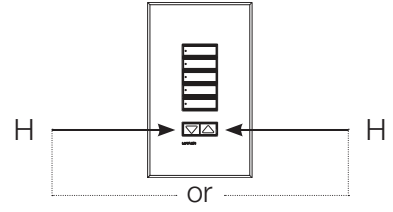

**12.4** Repeat steps 12.2 & 12.3 to adjust additional shades/draperies

**12.5** Store the current position of the shades/draperies by pressing and holding the desired Preset button for 5 seconds

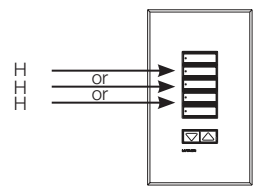

**12.6** Press and hold Open and Close simultaneously for 5 seconds to exit

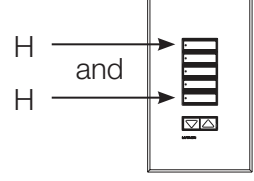

# 13

## Programming | Restoring Drive Default Settings

- Restoring a Drive to factory defaults will reset all keypad assignments but will not affect the open and closed limits.

### Returning a Drive to its Factory Default Setting

#### 13.1

Press and hold Close Limit button until LED flashes Green then turns on steady.

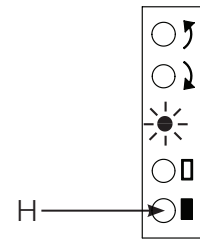

#### 13.2

Press and hold Open Limit button until LED flashes Green then turns on steady.

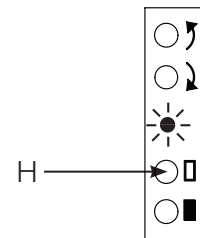

#### 13.3

Press and hold CW arrow button until LED flashes Green then turns on steady.

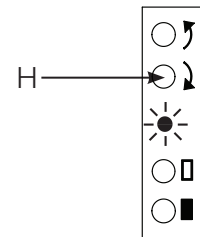

#### 13.4

Press and hold CCW arrow button until LED flashes Green then turns on steady.

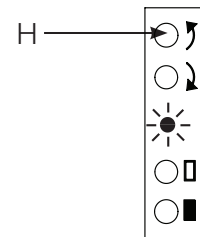



# 14

## Programming | Restoring Keypad Default Settings

### 14.1

Triple tap and hold the top button on the keypad.  
DO NOT release the button after the third tap.

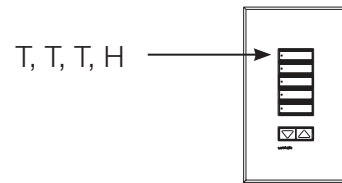

### 14.2

Keep the button pressed on the third tap until the LED next to the top button turns on solid (approximately 3 seconds).

### 14.3

Immediately release the button and triple tap it again. The LED next to the top button will flash quickly. When the LED stops flashing, the control has been returned to Factory Settings.

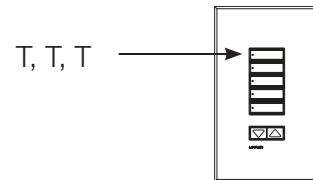

Symptom	Solution
<b>Drive will not move</b>	Drive is not powered - Check Drive power
	Fabric is obstructed - Free obstruction
	Drive not connected to keypad
<b>Drive does not fully open or fully close</b>	Limits have been set incorrectly - try using raise and lower buttons
	Fabric is obstructed - Free obstruction
<b>Drive opens when pressing close button, and closes when pressing open button</b>	Open and close limits have been reversed - Refer to "setting limits"
	Keypad wired incorrectly - Refer to wiring diagram
<b>Drive does not move smoothly.</b>	Check for binding of fabric
<b>Keypad will not operate drive</b>	Check that keypad is wired properly
<b>IR controls will not operate shade, keypads work properly</b>	IR transmitter does not have line of sight to IR receiver
	Out of range - Move to within 30 ft of IR receiver
<b>Tripping fuse or breaker in power supply</b>	Verify there is no obstruction in the path of the shade, drapery or carriers
	Verify the drapery stackback is not being over compressed
	Verify the Master Carrier is not driving into the idler end or adjacent Master Carrier

# Limited Warranty

## SCOPE

This limited warranty ("Warranty") covers the Lutron supplied (a) Sivoia Shade Systems ("Sivoia Shade Systems"), (b) manual shade system and (c) alternating current or a/c shade system (each of the foregoing being a "System"). Customer acknowledges and agrees that use of the System constitutes acceptance of all terms and conditions of this Warranty.

## LIMITED WARRANTY

Subject to the exclusions and restrictions described below, Lutron warrants that each System will be free from manufacturing defects from the date of shipment by Lutron for a period of (a) one year as to the wall controls, interfaces and system accessories of the Sivoia Shade System ("External Sivoia Components") and (b) eight years as to the other Systems and the electronic drive unit, shade fabric and shade hardware of the Sivoia Shade System. If any manufacturing defect exists in the External Sivoia Components, so long as Customer promptly notifies Lutron of the defect within the one year warranty period and, if requested by Lutron, returns the defective part(s), Lutron will, at its option, either repair the defective part(s) or provide comparable replacement part(s). If any manufacturing defect exists in any of the components of a System other than the External Sivoia Components, so long as Customer promptly notifies Lutron of the defect within the eight year warranty period and, if requested by Lutron, returns the defective part(s), Lutron will, at its option, either repair the defective part(s) or issue a credit to the Customer against the purchase price of comparable replacement part(s) purchased from Lutron as provided below:

Number of Years from Date of Shipment	Percentage of Cost of Replacement Parts Credited by Lutron
Up to 2	100%
More than 2 but not more than 5	50%
More than 5 but not more than 8	25%
More than 8	0%

Replacement parts for the System provided by Lutron or, at its sole discretion, an approved vendor may be new, used, repaired, reconditioned, and/or made by a different manufacturer.

## EXCLUSIONS AND RESTRICTIONS

This Warranty will be void, and Lutron and its suppliers will have no responsibility under this Warranty, if Lutron or its representatives cannot access any components of the System to inspect, diagnose problems with or repair the System or any of its components as a result of concealment or inaccessibility of such components within a building structure.

This Warranty does not cover, and Lutron and its suppliers are not responsible for:

1. Damage, malfunction or inoperability diagnosed by Lutron or a Lutron approved third party as caused by normal wear and tear, abuse, misuse, incorrect installation, neglect, accident, interference or environmental factors, such as (a) use of incorrect line voltages fuses or circuit breakers; (b) failure to install, maintain and operate the System pursuant to the operating instructions provided by Lutron and the applicable provisions of the National Electrical Code and of the Safety Standards of Underwriter's Laboratories; (c) use of incompatible devices or accessories; (d) improper or insufficient ventilation; (e) unauthorized repairs or adjustments or alterations; (f) vandalism; (g) an act of God, such as fire, lightning, flooding, tornado, earthquake, hurricane or other problems beyond Lutron's control; or (h) direct exposure to corrosive materials.
2. On-site labor costs to diagnose issues with, and remove, repair, replace, adjust, reinstall and/or reprogram the System or any of its components.
3. Components and equipment external to the System, such as, non-Lutron lighting and automation systems; building wiring audio-visual equipment; and non-Lutron time clocks, photosensors and motion detectors.
4. The cost of repairing or replacing other property that is damaged when any System does not work properly, even if the damage was caused by the System.

THIS WARRANTY IS IN LIEU OF ALL OTHER EXPRESS WARRANTIES. ALL IMPLIED WARRANTIES, INCLUDING THE IMPLIED WARRANTIES OF MERCHANTABILITY AND OF FITNESS FOR A PARTICULAR PURPOSE, ARE LIMITED TO EIGHT YEARS FROM THE DATE OF SHIPMENT, EXCEPT THAT SUCH IMPLIED WARRANTIES ARE LIMITED TO ONE YEAR FROM THE DATE OF SHIPMENT AS TO THE EXTERNAL SIVOIA COMPONENTS.

NO LUTRON AGENT, EMPLOYEE OR REPRESENTATIVE HAS ANY AUTHORITY TO BIND LUTRON TO ANY AFFIRMATION, REPRESENTATION OR WARRANTY CONCERNING THE SYSTEMS. UNLESS AN AFFIRMATION, REPRESENTATION OR WARRANTY MADE BY AN AGENT, EMPLOYEE OR REPRESENTATIVE IS SPECIFICALLY INCLUDED HEREIN, OR IN STANDARD PRINTED MATERIALS PROVIDED BY LUTRON, IT DOES NOT FORM A PART OF THE BASIS OF ANY BARGAIN BETWEEN LUTRON AND CUSTOMER AND WILL NOT IN ANY WAY BE ENFORCEABLE BY CUSTOMER.

IN NO EVENT WILL LUTRON OR ANY OTHER PARTY BE LIABLE FOR EXEMPLARY, CONSEQUENTIAL, INCIDENTAL OR SPECIAL DAMAGES (INCLUDING, BUT NOT LIMITED TO DAMAGES FOR PERSONAL INJURY, FAILURE TO MEET ANY DUTY, INCLUDING OF GOOD FAITH OR REASONABLE CARE, NEGLIGENCE, OR ANY OTHER LOSS

WHATSOEVER), NOR FOR ANY REPAIR WORK UNDERTAKEN WITHOUT LUTRON'S PRIOR WRITTEN CONSENT ARISING OUT OF OR IN ANY WAY RELATED TO THE INSTALLATION, DEINSTALLATION, USE OF OR INABILITY TO USE THE SYSTEM OR OTHERWISE UNDER OR IN CONNECTION WITH ANY PROVISION OF THIS WARRANTY, EVEN IN THE EVENT OF THE FAULT, TORT (INCLUDING NEGLIGENCE), STRICT LIABILITY, BREACH OF CONTRACT OR BREACH OF WARRANTY OF LUTRON OR ANY OTHER PARTY, AND EVEN IF LUTRON OR SUCH OTHER PARTY WAS ADVISED OF THE POSSIBILITY OF SUCH DAMAGES.

NOTWITHSTANDING ANY DAMAGES THAT CUSTOMER MIGHT INCUR FOR ANY REASON WHATSOEVER (INCLUDING, WITHOUT LIMITATION, ALL DIRECT DAMAGES AND ALL DAMAGES LISTED ABOVE), THE ENTIRE LIABILITY OF LUTRON AND OF ALL OTHER PARTIES UNDER THIS WARRANTY ON ANY CLAIM FOR DAMAGES ARISING OUT OF OR IN CONNECTION WITH THE MANUFACTURE, SALE, INSTALLATION, DELIVERY, USE, REPAIR, OR REPLACEMENT OF THE SYSTEM, AND CUSTOMER'S SOLE REMEDY FOR THE FOREGOING, WILL BE LIMITED TO THE AMOUNT PAID BY CUSTOMER FOR THE SYSTEM. THE FOREGOING LIMITATIONS, EXCLUSIONS AND DISCLAIMERS WILL APPLY TO THE MAXIMUM EXTENT ALLOWED BY APPLICABLE LAW, EVEN IF ANY REMEDY FAILS ITS ESSENTIAL PURPOSE.

THIS WARRANTY GIVES YOU SPECIFIC LEGAL RIGHTS. YOU MAY ALSO HAVE OTHER RIGHTS WHICH VARY FROM STATE TO STATE. SOME STATES DO NOT ALLOW LIMITATIONS ON HOW LONG AN IMPLIED WARRANTY LASTS OR THE EXCLUSION OR LIMITATION OF INCIDENTAL OR CONSEQUENTIAL DAMAGES, SO THE ABOVE LIMITATIONS OR EXCLUSIONS MAY NOT APPLY TO YOU.

## WARRANTY CLAIMS, TECHNICAL ASSISTANCE AND WARRANTY INFORMATION

Contact the Lutron Technical Support Center at the numbers provided below or your local Lutron sales representative with questions concerning the installation or operation of the System or this Warranty, or to make a warranty claim. Please provide the exact model number when calling.

USA and Canada (24 hrs/7days)

(800) 523-9466

Other countries (8 a.m. – 8 p.m. ET)

(610) 282-3800

Fax (610) 282-3090

<http://www.lutron.com>

## Worldwide Headquarters | USA

Lutron Electronics Co., Inc.

7200 Suter Road

Coopersburg, PA 18036-1299 USA

TEL: 1.610.282.3800

FAX: 1.610.282.3090

Technical Support: 1.800.523.9466 or 1.610.282.6701

Toll Free: 1.888.LUTRON

EMAIL: [shadinginfo@lutron.com](mailto:shadinginfo@lutron.com)

WEB: [www.lutron.com/shadingsolutions](http://www.lutron.com/shadingsolutions)

## Europe Headquarters | United Kingdom

Lutron EA Ltd

6 Sovereign Close

London, E1W 3JF, UK

TEL: +44.(0)20.7702.0657

FAX: +44.(0)20.7480.6899

Technical Support: +44.(0)20.7480.6899

FREEPHONE: 0800.282.107

## Asian Headquarters | Singapore

Lutron GL Ltd

15 Hoe Chiang Road

#07-03

Singapore, 089316

TEL: +65.6220.4666

FAX: +65.6220.4333

Technical Support: 800.120.4491

©2009 LUTRON Electronics Co., Inc.

P/N 045-314 REV. A