

4

3

2

1

- 1. CAD generated drawing - Do not update manually. This drawing to be used for reference only. Detailed model information is available from SolidWorks 3D files.
- 2. Decimal tolerances .X = ±.1 .XX = ±.01 .XXX = ±.005 unless noted.
- 3. Break all sharp edges to .01" unless noted.
- 4. Parts to have minimal burrs, sink marks and flash.
- 5. Material- Polypropylene 20% Glass Filled. Re grind allowed, 20-25% Max.
- 6. Color- Black.
- 7. EDM finish on all outer surfaces. No texture required on internal surfaces.

REVISIONS				
ZONE	REV.	DESCRIPTION	DATE	APPROVED
	A	Draft update and parting line change	7/11/2019	
	B	Update to Notes	7/11/2019	
A2	C	Update to draft (wall now 4 deg. for 8 deg. total) in side wall, snap shut off areas	9/6/2019	
	D	Part # added in title block	10/30/2019	
	E	Drawing Name Update	2/17/2021	

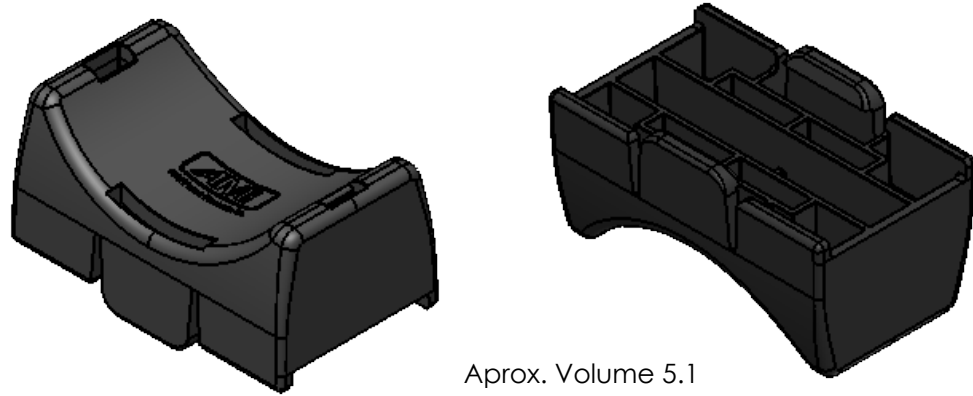

Aprox. Volume 5.1 cubic inches

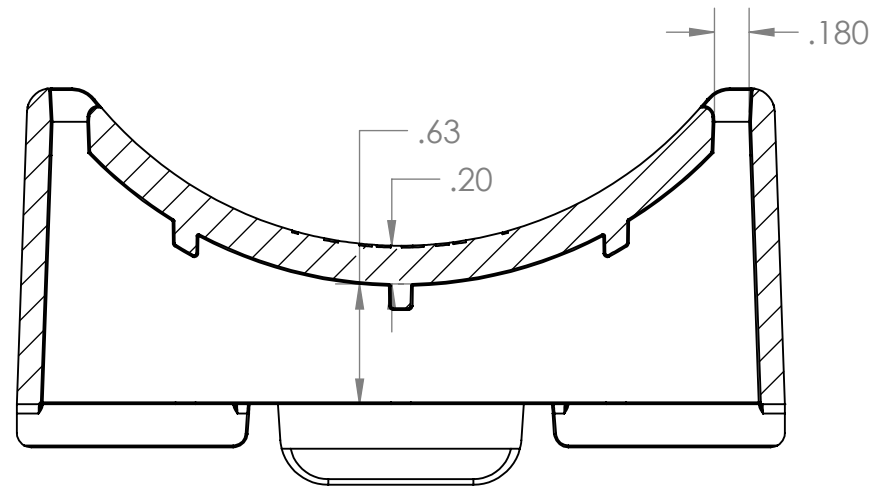
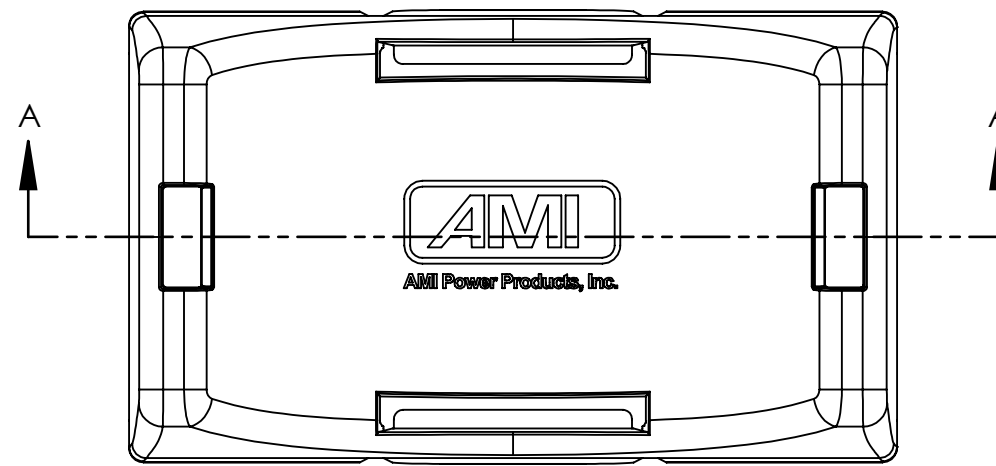

SECTION A-A

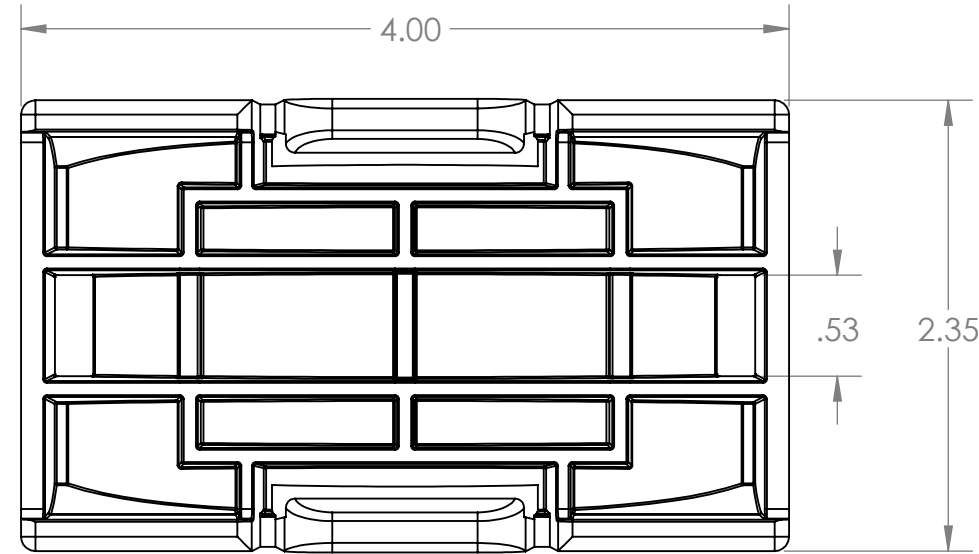
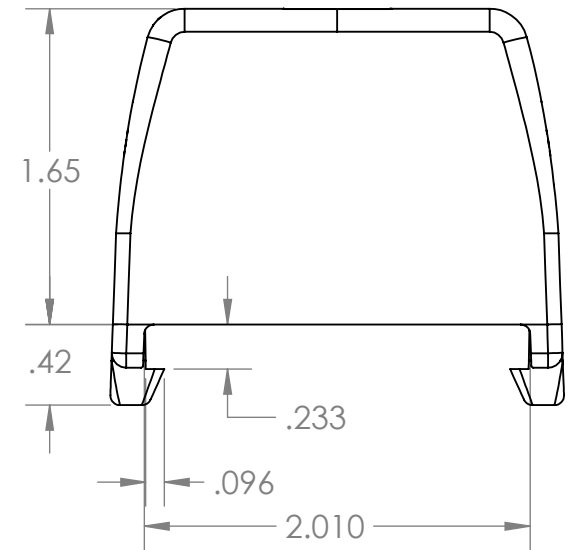
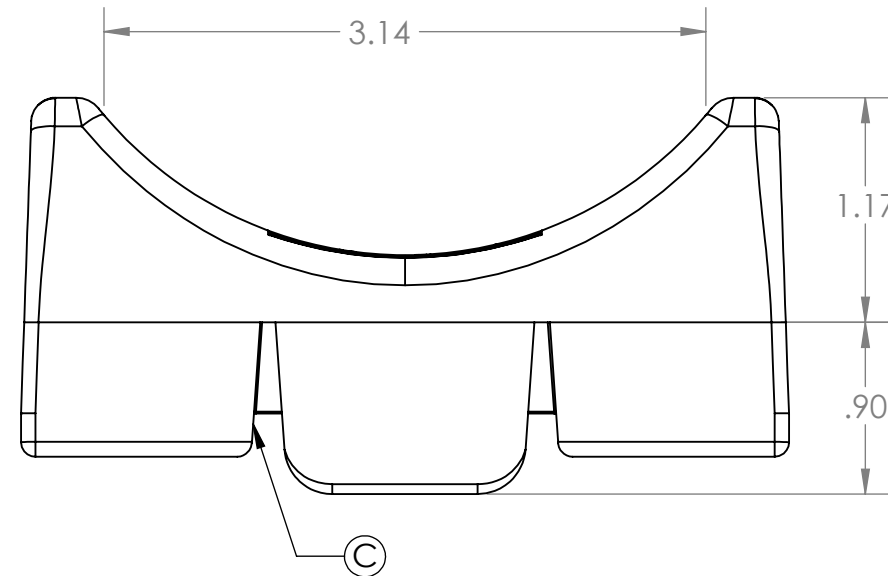

Poly Saddle is compatible with the following brackets/Cable Stanchions/Rack Arms

Hubbell / Chance
DU1S Series Brackets

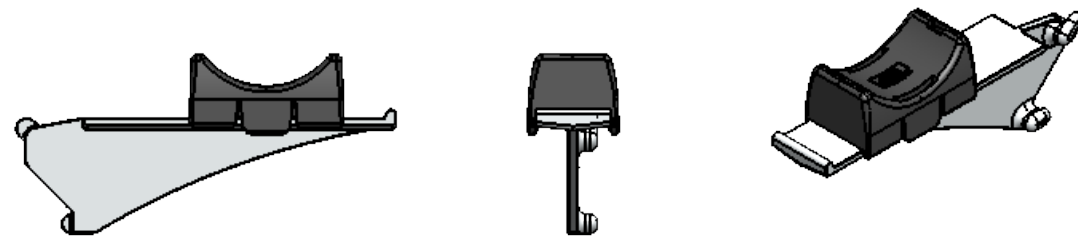

Saddle needs to fit over stock brackets. Will develop a test fixture for in process checks.

POLY-SADDLE



PROPRIETARY AND CONFIDENTIAL

SIZE B	DWG. NO. PCS-HD	
SCALE: 1:1	DATE: 2-17-2021	
		SHEET 1 OF 1

4

3

2

1