

FAMA.K/M
drawer systems

**FAMA pharmacy drawers -
highest quality to meet the greatest demands.**



Willach

Pharmacy Solutions

Modern pharmacies work with FAMA.

For more than 40 years Willach has been setting standards as the market leader in the production of pharmacy equipment. Europe's most modern pharmacies are using FAMA drawers instead of inefficient open-shelf storage. Willach's FAMA drawers provide the highest quality and precision with proven performance. Due to well thought-out design and advanced technology they can last a whole generation of pharmacists and even longer.

Benefits:

Professional appearance

The whole back-office work area becomes tidy, well organised and professional.

Space gain

Compared to open shelves, drawers achieve much higher storage density. That creates more space for additional work surfaces, consulting rooms or shelves for retail products.

Improved organisation

Product storage is clearly arranged so packs can be found more quickly. That saves time and minimises errors when dispensing packages.

Ergonomic work environment

The self-closing mechanism means that the drawer closes almost automatically. The integrated carriage step allows for easy access to the upper drawers.

Safely protected

The drawers can be locked to protect the medicines against unauthorised access.



FAMA.K

drawers

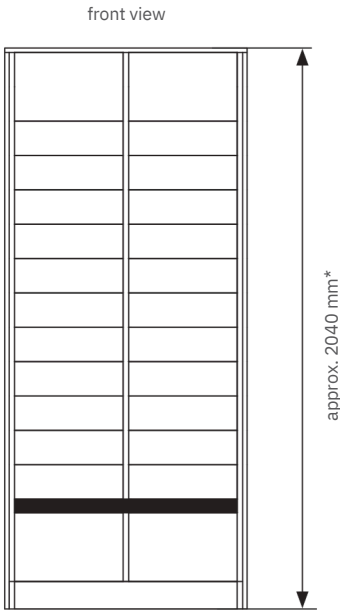

*also available in 1540 mm

Available depths:

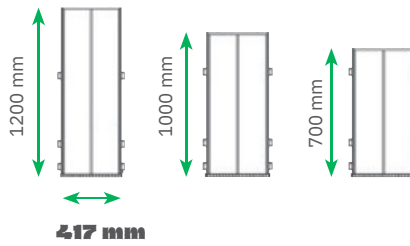

1 bay of FAmA full-height drawers

Standard configuration (example):

11 single-height drawers (125 mm)
2 double-height drawers (250 mm)
1 carriage step



FAMA.M

drawers

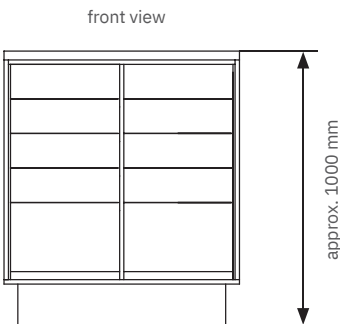

Available depths and widths:

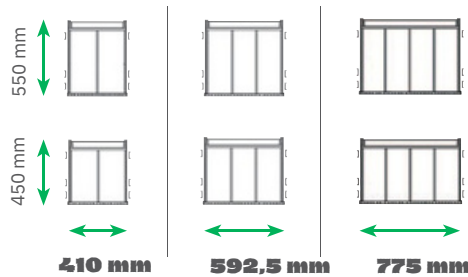

1 bay of FAmA underbench drawers

Standard configuration (example):

4 single-height drawers (125 mm)
1 double-height drawer (250 mm)



Effective organisation – well thought-out in the finest detail.

FamaK and M drawers are the ideal solution for quick access, great visibility, maximum use of space when stocking medicines and perfect ergonomic operation.

Optimum adjustment for different package sizes:
Cross dividers of heights 70, 105 and 140 mm.

FAMA.K
drawer

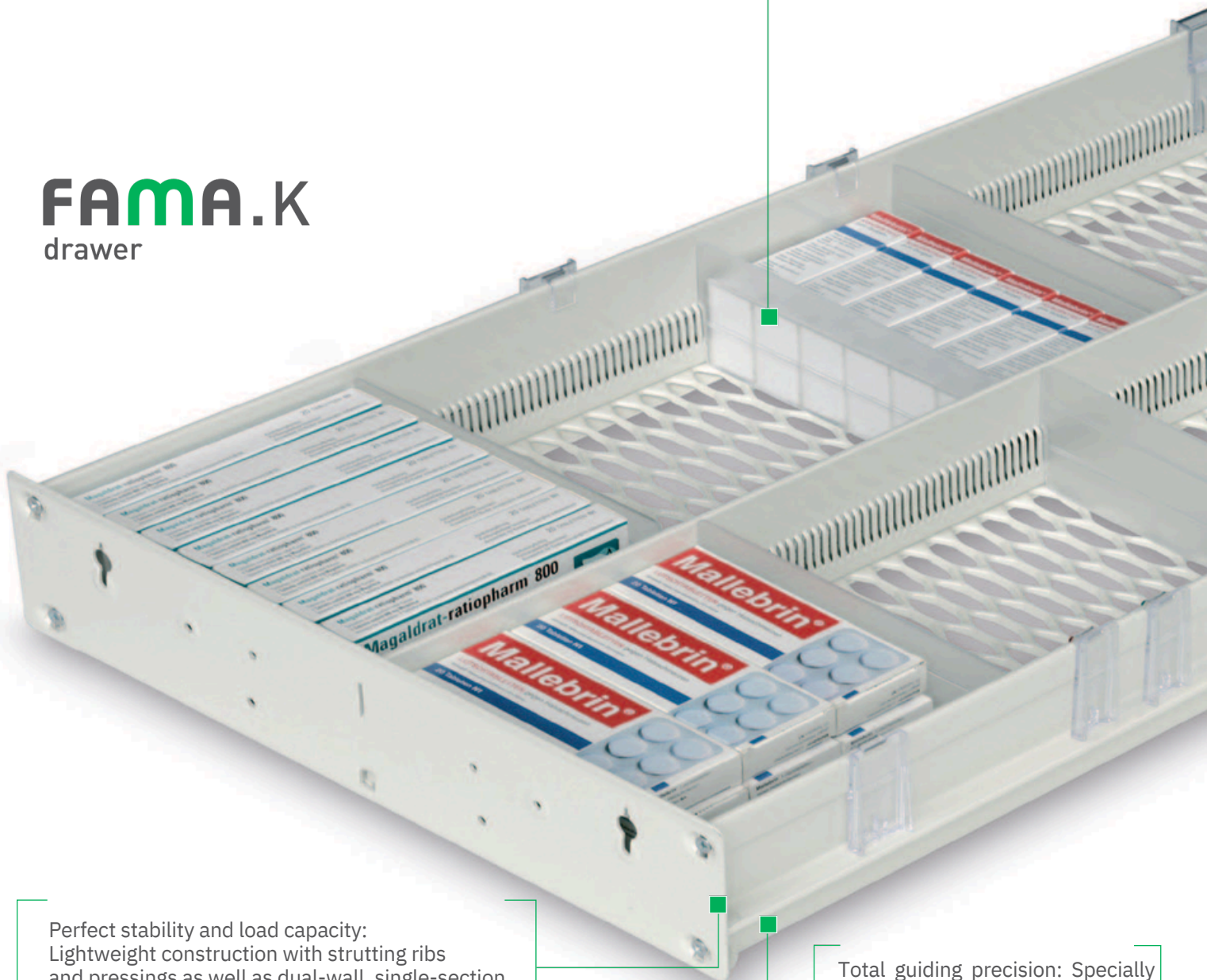

Perfect stability and load capacity:
Lightweight construction with strutting ribs and pressings as well as dual-wall, single-section sides.

High corrosion protection:
All cavities have been phosphatised or galvanised.

Outstanding surface protection:
Powder coating covers all edges, stops abrasion, prevents dust and provides easy care.

Total guiding precision: Specially shaped precision tracks on both sides of the running surfaces ensure FAMA drawers are easy to open and self-close smoothly.

Practical and hygienic:
The wire-mesh base lets
you see all the contents of the
drawer from below and makes
it considerably easier to clean.

Secure hold:
Rib-shaped slots for
cross and grid dividers.

Fast overview:
Grid dividers with integrated
label holder.

Safe identification of
packages:
Flush label holders enable
barcodes to be attached.

FAMA.M

drawer

Fast locating:
Card holders help you
find precisely the right
package.

Smooth running:
For silent operation,
plastic-sheathed steel
ball bearing rollers
run on powder-coated
surfaces.

Durable steel ball
bearings:
Dust-proof, sealed
and prelubricated on
both sides.

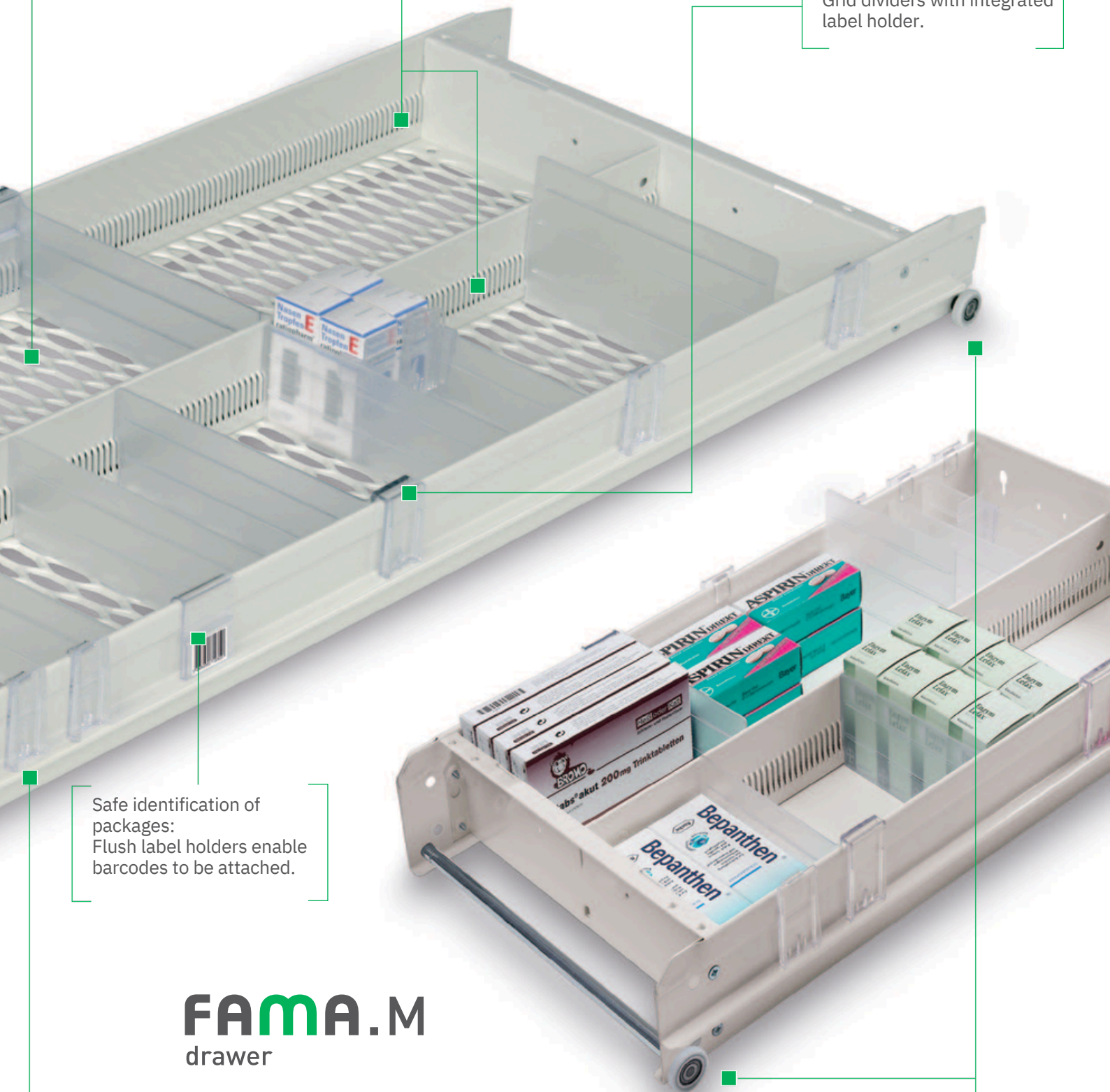

Intelligent design for the highest standards.

Specially designed running tracks enclose the left and right support rollers with an exact fit, ensuring that unique FAMA guiding precision. This means that the drawers open and self-close effortlessly.

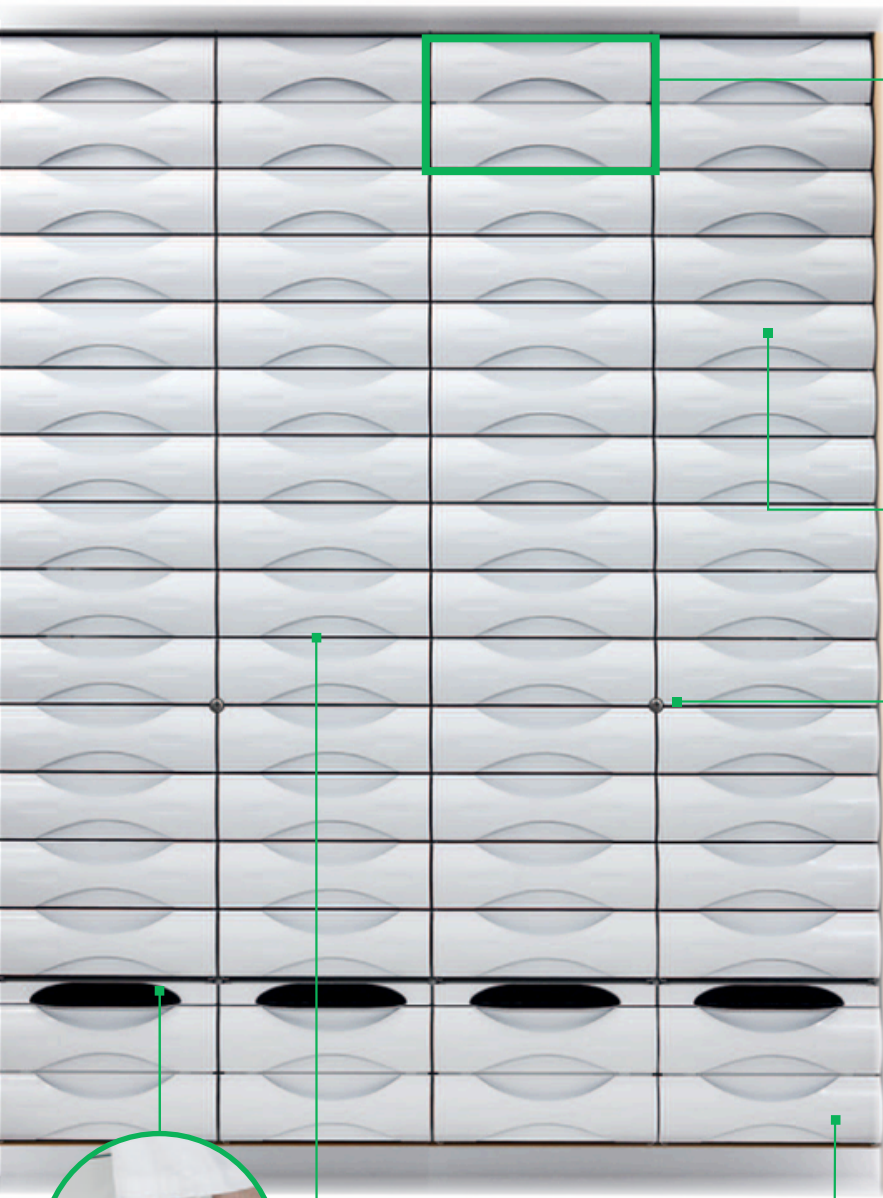

Bulk item double-height drawer

For storage of large and heavy packages and containers.

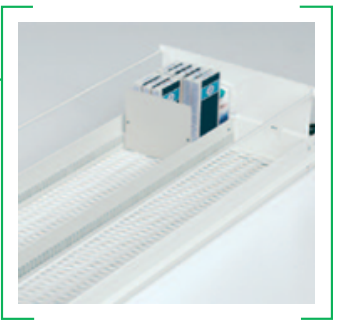

FamaVisionfronts

Available in 28 colours.



Lockable FAMA

drawers are also available with locks to prevent unauthorised access and to meet statutory requirements.



FAMA carriage step

Simple and safe access to the upper drawers.



Precision drawer-front alignment across all bays

Ensures a uniform and seamless look.

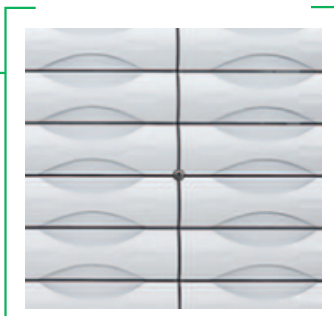

Easy-find product system

Ensures that medicines are easy to find.



Individual look in shape and colour.

It's your choice: there are 28 different colours for Fama Vision steel fronts*. Thanks to a clip-on mechanism, they are simple and cost-effective to fit. A clean joint pattern is guaranteed.

Alternatively, fronts made of wood or other materials can be fitted.

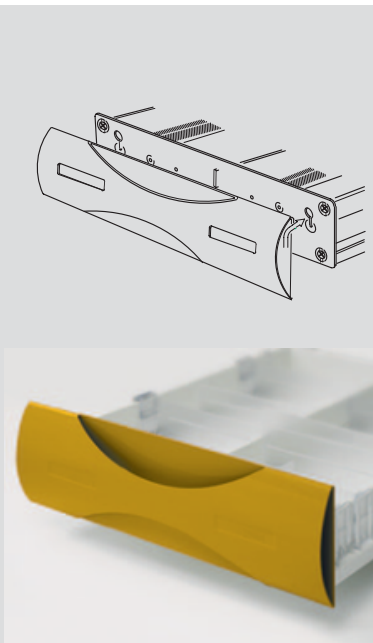

* Only available for c/c measurements 410 and 417 mm.

Standard

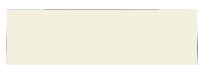

Willach white (R9002)



Signal white (R9003)

Standard Plus

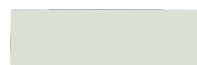

Willach silver grey metallic (R9007)

Special colours



Ivory (R1014)



Zinc yellow (R1018)



Melon yellow (R1028)



Pastel yellow (R1034)



Pastel orange (R2003)



Carmine red (R3002)



Ruby red (R3003)



Rose (R3017)



Traffic red (R3020)



Salmon pink (R3022)



Claret violet (R4004)



Signal blue (R5005)



Cobalt blue (R5013)



Pastel blue (R5024)



Yellow green (R6018)



White green (R6019)



Signal green (R6032)



Nut brown (R8011)



Window grey (R7040)



Blue grey (R7031)

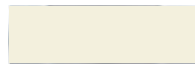

Cream white (R9001)



Pure white (R9010)



White aluminium (R9006)



Anthracite (W0001)



Anthracite grey (R7016)



Willach Pharmacy Solutions.

The right prescription for every pharmacy.

Willach is the market leader in Europe for medicine storage and dispensing equipment. With our FAMA drawer and shelving systems and CONSIS robotic dispensers we can provide a uniquely tailored solution for any type of pharmacy, and any size of pharmacy. All Willach systems are subject to rigorous testing and demanding quality standards at our product development and production facilities in Germany.

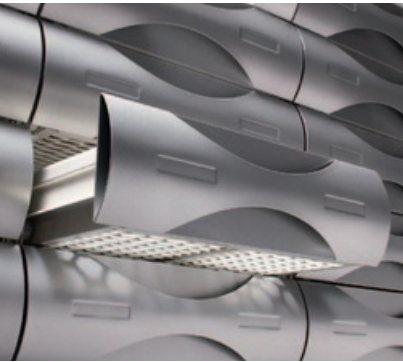

FAMA drawer systems

Fama large-capacity and underbench drawers provide fast access to packages, with good visibility, excellent space utilisation and ergonomically perfect operation. No other system offers you drawers which can store more packages in the same space.



FAMA shelving systems

Fama worktop and fast mover shelves were developed as a modular system to achieve the greatest possible flexibility. They can be precisely adapted to your individual requirements. Fama round shelves store fast moving items to provide direct access and can be flexibly configured.



Willach

UK Sales Office:
Willach UK Ltd
Concorde House
Trinity Park, Solihull
Birmingham B37 7UQ
United Kingdom

Phone +44 (0) 121 635 5025
info.uk@willach.com
www.willach.com

German Head Office:

Willach Pharmacy Solutions GmbH
Stein 2
53809 Ruppichterath
Germany
Phone +49 (0) 2295 9208 0
Fax +49 (0) 2295 9208 499
info@willach.com
www.willach.com

Willach Group

Represented in Saudi Arabia by



شركة السماعيل للصناعة
Alismail Industrial Co.

Alismail Industrial Co.
www.alismail.com