

# ARCHERY

U.S. OPEN  
First Report



New Game  
for Archers

Winning and  
Mental Control

Report on  
NFAA Board Actions

March, 1973 60¢





**EASTON X7® XX75® 24SRT-X®**

THE WORLD'S FINEST ARROW SHAFTS  
7800 HASKELL AVENUE, VAN NUYS, CALIFORNIA 91406 • (213) 782-6445

# ARCHERY



Official publication of the National Field Archery Association, Route 2, Box 514, Redlands, Calif. 92373. Phone (714) 794-2133. Published monthly by the National Field Archery Association

Dan Gustafson Editor  
Ruth Hathaway Advertising Coordinator

## NFAA OFFICERS

Ervin G. Kreischer, President  
827 Floretta Dr., N.W.  
Albuquerque, New Mexico 87107

John W. Durham, Vice President  
2604 So. 19th St.  
Ft. Pierce, FL 33450

E. Pat Winfield, Immediate Past President  
1123 Los Palos, Apt. 4, Salinas, California 93901

Wm. H. Wadsworth, Bow Hunting Chairman  
Boy Scouts of America  
New Brunswick, New Jersey 08904

Ervin W. Belt, Executive Secretary  
Route 2, Box 514, Redlands, California 92373  
(714) 794-2133

Subscription rates: \$5 per year in U.S.A., Canada and Mexico. Foreign subscriptions: \$7. Special rate to dealers (U.S.A. and Mexico only): \$2.50 per year per subscription in lots of five or more sent to one address. Order must appear on dealer's letterhead or order form. Single copy 60c.

Advertising rates on request.

Second class postage paid at Redlands, Ca.; and additional mailing offices.

Articles, stories and club news must be submitted for publication showing name and address of the writer. All statements are those of the writers, and may not conform to the editorial policy or views of this magazine — or the editor. Deadline for copy: six weeks prior to the month of publication.

Postmaster: Please send Form 3579 to:  
National Field Archery Assn.  
Rt. 2, Box 514, Redlands, Calif. 92373

MARCH, 1973 VOLUME 45, NUMBER 3

COVER: The only event in which you can win a genuine silver dollar, is the annual Las Vegas Archers Silver Dollar Tournament. Shown are members of the club at their Cougar Canyon field range. They are: Gary Noe, Reba Noe, Al Rosencrans, and Dian Allen. —Photo by Roy Hoff

## Action Features

U.S. Open	8	by Dan Gustafson
Power of the Mind	16	by Freddie Troncoco
Bad Break Bowhunt	20	by Richard Schreiber
Instinctive Shooting	24	by Bob Walker
Biography of One Bowhunter	40	by Dick Sage

## Archery Personalities

Archery Forum	4	by Durwood Nails
What's Your Problem?	6	by Freddie Troncoco
Strictly for Bowhunters	18	by Dick Sage
Tales of the Feathered Shaft	38	by Roy Hoff

## NFAA Speaks

Points	26	by Erv Kreischer
Headquarters Report	28	by Erv Belt
Sectional Report	32	
Coming Events	45	

## Subscribe to Archery

Keep current with 12 issues of ARCHERY filled with technical tips, personality profiles, hunting hints and nationwide activities of bowhunters and field archers.

(U.S., Canada, Mexico) (Foreign)  
 \$5.00 per year       \$7.00 per year

Name \_\_\_\_\_

Address \_\_\_\_\_

City \_\_\_\_\_ State \_\_\_\_\_ Zip \_\_\_\_\_

Mail with check to:  
ARCHERY Rt. 2, Box 514, Redlands, CA 92373



# SAVE!

BUY FACTORY-DIRECT.....  
from world's leading manufacturer

All Sport  
and  
Event  
Figures  
Available

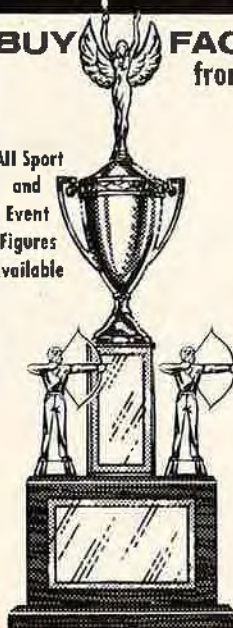

Assembled - ready to present

Wholesale low, low prices

Artistic color combinations

Rush "PDQ" service

Distinctive designs

Satisfaction guaranteed

Highest Quality Sculptured and  
Enameled Medals For All Events

Beautiful Award Charms

Write for free catalog

**Trophyland USA Inc.**

DEPT. A, 7001 W. 20th AVE., P.O. BOX 4606, HIALEAH, FLA. 33014

## MULTI-FLETCHER

FLETCH 6 ARROWS IN ONE JIG  
AVAILABLE WITH STRAIGHT, RIGHT OR LEFT HELICAL CLAMPS

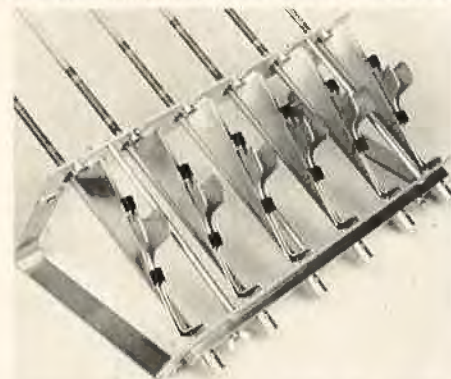

### BIG SHOOT TOMORROW/ FEATHERS SHOT UP?

No problem when you own a MULTI-FLETCHER.  
Fletch 6 shafts in 2 hours — be ready for that  
big tournament or hunting trip tomorrow.  
Select 3 and 4 feathers or 3-6 and 4-75°x105°  
Reversible Nock Receivers.

We also have the MONO-FLETCHER an economy model  
that fletches a single arrow, but still uses the fine  
clamp and nock receiver as our MULTI-FLETCHER.

See your dealer or send for brochures  
**J. G. GEBHARDT CO.**

RT. 1 BOX 90 QUEENSTOWN, MD. 21658

FORUM by DURWOOD NAILS

## A new game

SURELY you will agree that archery will someday evolve into a sport with many very interesting games. At present, the games are primitive and offer only one aspect of competition, that aspect being the archer's ability to hit what he is aiming at. Thus, there is limited interest.

One exception is that on a field range the archer's ability to shoot under varied conditions of terrain and distance for each target is tested.

The game outlined here offers three new aspects of competition normally found in more popular participant and spectator sports:

(1) The archer would have to make a decision before shooting each arrow, that is, which bull's eye to aim at commensurate with his ability.

(2) The shooter would be obliged to correctly assess his own ability in order to score the potential that he is capable of; an error in judgment would be costly.

(3) The competitor would have a chance to gamble and catch up, or fall further behind, as the case may be.

With this system of scoring, each and every target would be a challenge to all archers with no "easy" targets. It would allow the best archer to prove that he is best, or at least a better judge of his own ability. The scores of the weaker archers would not be so bad that the archer would feel hopeless and therefore lose interest.

This scoring system could not be adopted on the present field or hunter face; but the new target face would adapt itself well to the present field layout, or International field round or PAA round. Someday a system such as this will be used; the sooner the better.



Target face for hunter round*	Target face for field round	Diameter of target	Diameter of zero bull	Diameter of "1" bull	Diameter of penalty "3"
Birds	Birds	8	1	2	3
15-32 yds.	15-30 yds.	16	2	4	6
36-53 yd. Walk-up	35-50 yds.	24	3	6	9
up to 70 yds.	55-80 yds.	32	4	8	12

\*Reverse colors for hunter round

### Scoring is Negative

Study the target face. You will note that the scoring is negative; that is, the low score wins (negative scoring is simpler with less arithmetic, thus fewer errors and less lost time at the target scoring.) You will notice that a score of zero would be perfect (but, I believe, impossible). The "0" bull's eyes are protected by a "3" ring, which makes the penalty for missing costly. The "1" rings are larger, but are located on the bottom of the face where they are a risk to shoot at.

Four arrows would be shot at each target; and as at present, an arrow cutting a line would be scored in the most advantageous area for the archer. Scoring would be: "0," "1," "2," off-the-face: "3;" or penalty area: "3." The "0" ring would be exactly the same size as the present aiming dot on all our field faces today, with the "1" ring exactly twice that diameter. The hunter face would be opposite in color from the field face, but would have the same dimensions.

Animal round scoring would be: limit, three arrows; first arrow brain shot score "0," heart shot "3," hit "4;" second arrow brain shot "4," heart shot "5," hit "6;" third arrow brain shot "6," heart shot "7," hit "8;" miss would be "9."

In this game, whether shooting field, hunter, or animal, the archers must change positions on every target. That is, if you shoot first on target number "1," you shoot last on target number "2" — first on all the odd numbered targets — last on all the even numbered targets. The reason for this is that if the scoring is close the pressure of deciding which bull to shoot at (or how much to gamble) is much greater on the archer who shoots first.

### Par Values

Par values should be established for all different divisions at some time in the future but, to begin with, a par value is not really necessary, as its only purposes are to simplify scoring and to establish a standard of proficiency. For that very reason it would be better to wait and let experience show us what the par values really are. If a par value is demanded now, my hazardous guess is that they would be in the neighborhood of the figures on the chart. They are based on shooting four arrows at each target.

The hunter round face would be exactly like the field face except that the colors of the bulls and X's would be reversed. The dimensions for the field and hunter faces at specific distances are also shown below.

TARGET	SUGGESTED PAR VALUES					
	men FS	wom FS	men BB	wom BB	men BH	wom BH
Field birds	3	4	3	4	5	6
Hunter birds	3	4	3	4	5	6
15 yd. Field	2	3	2	3	4	5
15-14 yd. Hunter	2	3	2	3	4	5
20 yd. Field	3	4	3	4	5	6
19-17 yd. Hunter	3	4	3	4	5	6
25 yd. Field	4	5	4	5	6	7
23-20 yd. Hunter	3	4	3	4	5	6
30 yd. Field	5	6	6	7	7	8
28 yd. Hunter	4	5	4	5	6	7
35 yd. Field	3	4	3	4	5	6
32 yd. Hunter	5	6	6	7	7	8
40 yd. Field	4	5	4	5	6	7
36 yd. Hunter	4	5	4	5	6	7
45 yd. Walk-up	4	5	4	5	6	7
40 yd. Hunter	4	5	4	5	6	7
45 yd. Field						
44 yd. Hunter	5	6	6	7	7	8
50 yd. Field	6	7	7	8	8	9
48 yd. Hunter						
55 yd. Field	4	5	4	5	6	7
53 yd. Walk-up Hunter	6	7	7	8	8	9
60 yd. Field	5	6	6	7	7	8
58 yd. Walk-up Hunter	4	5	4	5	6	7
65 yd. Field	6	7	7	8	8	9
64 yd. Walk-up Hunter	5	6	6	7	7	8
80 yd. Field	6	7	7	8	8	9
70 yd. Hunter						
<b>Total Field</b>	<b>60</b>	<b>74</b>	<b>66</b>	<b>80</b>	<b>88</b>	<b>102</b>
<b>Total Hunter</b>	<b>60</b>	<b>74</b>	<b>66</b>	<b>80</b>	<b>88</b>	<b>102</b>



### Hit and Miss

Freddie:

Could you please advise a 47-year-old woman how to keep from hitting her bow arm. I try to roll my shoulder, but can't seem to get the arm out of the way. Any tip you can give would be appreciated.

Also, do you know where I could get a sight scale ruler to set up sights if one distance is right?

Lucy Rollins  
Lancaster, S.C.

•The problem you describe has many possible causes. I sincerely recommend seeking professional advice by visiting your local pro-shop and having an instructor watch you in an effort to correct your particular problem.

You may try raising the fistmele or brace-height of your bow. I had to raise the fistmele on my wife's bow up to 10 1/4" before we accomplished complete string-clearance of her arm. This and rolling the elbow tip outward before drawing and execution of each shot solved her problem.

According to some information obtained from fellow archer John Williamson, you may write to Sherwood Schoch for this information. His address is: 26 N. Washington St., Boyertown, Pa. 19512.

### Sight Unseen

Freddie:

When shooting the field round with a peep-sight, it's impossible to shoot from 15 yards to 80 yards without moving the peep or your anchor. I've tried the slotted peep & one with two holes, but found them inaccurate!

Is there a technique or trick that pro's like yourself use? Any help would be greatly appreciated. My equipment is as follows: 70 in. HC-300, 35 lbs., 29 in.; X-7's 1816; Berger Button; weighted tips; 3 in. feathers; and a rope release.

Frank Yodice  
Bronxville, N.Y.

•I recommend using a small (outdoors - .50, indoors - .70) single-hole peep-sight for maximum accuracy.

The problem you describe can be conquered by establishing a fairly solid under-the-chin anchor while sighting in and locating position of peep-sight while shooting from a distance of 80 yards to begin with. You will thus be required to pull-up into your chin slightly tighter at 15 yards if you choose to take this alternative.

Should you establish your anchor point and locate peep-sight at close yardages, you will find it necessary to open your mouth slightly in order to view front-sight through peep-sight at long yardages. This factor is further augmented by the use of extended sight bars on long extensions which open up your sight markings adding to the existing problem.

By mounting your sight on the face of the bow, the inside portion of handle facing you at full-draw, the sight markings will be much closer together minimizing this phenomena.

I prefer sighting in and properly locating your peep-sight at mid-ranges of 40-50 or 60 yards. Do not overlook the fact that only one arrow is shot from each distance of 70 and 80 yards per each 14 target segment of a field round.

### Tackle Technicalities

Freddie:

I have a 45 to 60 lb. Jennings Compound bow which I bought last year from my good friend Ron Carlson in St. Paul. I had a lot of trouble getting good arrow flight and grouping so I sent the bow back to Ron a couple of times and he set it up to where I shoot my regular average, about 295 indoors.

Outdoors I shoot around 530 to 540. I would like to give you in detail exactly what I shoot and maybe you could help me for the outdoor season this year. Here is what Ron has set up for me and what I now am shooting:

Right-hand Jennings Compound, 45 to 60 lb. which is set at 45 lb. and breaks to 35 lb.;

I have a 14 strand string with No. 18 mono-serving, nocking point is 12 in. above 90°;

Berger Button and Carlson wire rest;

Jennings stabilizer 28 in. with 3 oz. weight;

I shoot X7-1814 and X7-1816 at 28 1/2 in. I use regular points 1/4 in. Bjorn nocks.

I shoot with one of Pete Shepley's new plastic releases with a brass pin in it, and rope, similar to the one you showed in one of your articles.

I shoot Pete's rubber vanes, the PF-230, indoors on my X7-1816, 28 1/2 in. arrows. Outdoors I would like to shoot the PF-180, would they work? My bow is set up to shoot X7-1814 at 28 1/2 in. long. The arrows fly beautiful and group real well indoors.

For the outdoor season this year, should I shoot the X7-1814 at 28 1/2 in. long with regular points and PF-180 vanes which are 1 3/4 in. long? Or do you think it would be better to stick to X7-1816 at 28 1/2 in. and use PF-230 rubber vanes?

I think that the X7-1814 might not fly as well through the wind as the X7-1816. Could you suggest what size shaft to shoot outdoors? Last year I was shooting X7-1816 with PF-230 and they flew and grouped real well, but everybody that shoots a compound around here says to use the 1814 and PF180 instead of 1816 and PF 230. What do you think?

I used to shoot one of Pete's plastic releases, the Model - S Hook. You pull with two fingers and trigger with the third one, but I broke five this year already indoors. I talked to Pete and he sent me the one with the brass pin and rope.

Also, Ron set the tiller on my bow at 10 in. on the top limb and 9 7/8 in. on the bottom. Everybody that I see shooting around here uses only 9 1/2 in. or 9 3/8 in. Do you think that's too much of a tiller on a compound?

Oh yes, do you know where I can get a release like the one Vic Leach was shooting two years ago when he won the Nationals? It had a little wire or pin in it. Could you get me one?

Ted Wiktorek  
West Allis, Wisc.

•Knowing my good friend Ron Carlson set your compound bow up, I personally guarantee he won't steer you wrong. The set-up you describe sounds good to me.

Using a release, I believe you could adequately get by with the smaller PF-180's since the arrow does come out of the bow straighter with virtually no paradox. The spine matching factor is also reduced which would allow you to possibly shoot the 1814's.

By the description of your scores, I'd say you are shooting very well and should concentrate solely on your shooting form.

The release used by Vic Leach was a "Frank Ketchum" brass-ledge release. Vic simply added a two-piece of surgical gum-rubber tubing and slipped it over the triggering end of the release. You may order one from: Bonnie Bowman Archery, 2007 High St., Alameda, Calif. 94501 or Frontier Archery, 3440 La Grande Blvd., Sacramento, Calif. 95823. Note: Vic Leach works at Frontier.

### Compound Query

Freddie:

I am planning on buying a compound bow in the near future. I would like your opinion on which one is the best, "Jennings" or "Olympus"?

Harold King  
Staten Island, N.Y.

•Not having tried the Olympus Compound, I do not believe I could fairly give you an honest answer.

I do know that Jennings has put together quite a few compounds and has, in my opinion, gained tremendous insight and developed several technological improvements of the bow. Jennings is, for example, perfecting an all new metal handle which will be placed on the market very soon.



**GOT A PROBLEM?**

**WRITE FREDDIE**

1851 Orange Avenue  
Monterey Park, California 91754

Record-breaking  
WINNER OF  
**2 GOLD  
MEDALS**

Sweeps 4 out of 5  
Archery Medals in  
the Olympics!

**PRO MEDALIST T/D**

A masterpiece of skilled engineering craftsmanship... with every detail diligently planned for total accuracy! The Pro Medalist Take-Down Bow brings you the ultimate design, backed by 20 years of traditional quality and proven consistently through the years as the "World's Most Accurate Bow."

Sculptured, lightweight magnesium handle comes in 3 sizes and provides for a full range selection of weights and stabilizers to improve your shooting skill. Exclusive, patent-pending limb mounting system has precision-machined bearing surface. Easy, snap-in, snap-out limbs lock in position to insure perfect, solid alignment every time without rattle or squeaks. No tools required. Interchange limb lengths, convert from Hunting to Tournament bow with just a snap. Proven, super-flex, action-powered limbs deliver smooth, quiet speed with a consistent accuracy that will amaze you.

Join the list of champions — see your authorized Hoyt Dealer, or write for information.

**HOYT**

11510 NATURAL BRIDGE ROAD, BRIDGETON, MISSOURI 63042





TOP FOUR archers in the men's unlimited division were Gene Parnell, Ellis Gibson, Blair Peterson and Mike Binney. If Mike is the only one who looks relaxed, it may be because the others were contemplating the sudden-death shoot-off ahead of them which broke their three-way tie at 898.

## THE \$21,000 U.S. OPEN

New faces and more ways to win at Las Vegas

AMONG the individuals who are the "organization men" in our sport — people like manufacturers, club and association officers, tournament promoters and sponsors — there is hardly a man whose heart is not warmed by the sight of new faces in archery.

The 1973 U.S. Open was a heart-warming experience, in many ways, but particularly because 638 archers toed the line, over 200 more than attended last year.

What was it that brought this encouraging turnout of shooters to Las Vegas? No one could pinpoint a single cause, but the advance publicity, aimed more at attracting the average shooter than courting the pro, must have helped boost attendance. Like the fellow at the crap table said, there were lots of ways to win.

Wider distribution of the prize money down through the flights, for example, enabled Dave Matlo, of Grand Junction, Colorado, to finish 102 points behind the high scorer with a respectable 796 and still pocket \$100 for his first place finish in flight 8.

For the barebow shooters, there was recognition in the form of

their own purse to shoot for, while NFAA members turned out in unexpected numbers to hold their own successful \$1,000 money shoot. The two team events presented two additional opportunities to take cash home, and the bonus awards of 25 silver dollars were given for everything from recording a Robin Hood to being the best dressed left-handed archer, an honor which fell to Don Kouns, of San Jose, California, who looked even better posting a 300 score.

It was a tournament that gave the guy who pays the freight, the average shooter, his due.

Did this democratic format shortchange the pros? Admittedly, first place money totalled less than half of last year's winner's purse — \$500 rather than \$1,250 for the top unlimited and limited ment, and \$250, down from \$500, for the women. The pros also felt the effect of the most obvious new "face" at the Open, the Las Vegas round target, which, as antici-

*Biggest bow case was one category for which there was no bonus award given, but John Lirou probably would have won.*

pated, reduced the floor of 300's posted in previous years to more of a trickle with inside-out scoring. Still, there were a half-dozen or so 300's shot into the 3 in. bull of the 16 in. multi-colored face, admirable shooting considering liners didn't count.

With six arrows per end and six minutes to shoot them, some pros felt the pressure of the clock, but the tournament did move along at a good pace. That, of course, is the



purpose of time limits, and while imposing them can be a delicate matter, they appear to be necessary. There undoubtedly is no way to please all of the shooters all of the time, but if you are attempting to be democratic, you try to satisfy most of them.

No archers there could have been more satisfied than three pros who, incidentally, fall into that category of new faces at Vegas. Gene Parnell, Ellis Gibson and Blair Peterson finished an exciting shoot-off in that order to command the top of the men's unlimited rankings. These men accounted for four 300's, four 299's and a single 298 score to finish the three rounds in a three-way tie at 898. Quick addition shows that Blair Peterson had to combine his 298 with two perfect 300's to reach that total.

We heard no complaints about the amount of their winnings from these gentlemen. Certainly no one can walk away from any archery tournament today a significantly richer man in terms of thousands of dollars; the real thrill and enrichment comes from competing with the best at a well-run tournament, and winning.

Just who came out on top in the shoot-off was determined by an official ALOA test face with a three-inch gold further divided into a one-inch center, scored 10 points, a two-inch ring, scored 9 points, the three-inch ring, good for 8 points, and so on. Predictably, only one six-arrow end with 60 points possible was needed to determine the first place winner, yet the shoot-off had all the elements of tension, concentration and spectator interest as the resolution of a four-way tie last year. For the clincher, even the shoot-off was scored *inside-out*.

Gene Parnell, the cool cowboy from Wyoming, put on a display of incredibly tight group shooting into the one-inch ten ring. Parnell scored 56 out of 60 for the end, giving him a victory by a two point margin over Ellis Gibson.

Judging from the performances of Gibson and Peterson, we'll be seeing more of these fine competitors. Gibson's rise in archery has been meteoric and only slightly flawed by two miscues at the Open. Ellis, who resides in Little



Above: "Gentleman Jim" Pickering poses with an example of his fine shooting which brought him first place in the men's limited division. Right: Officials carefully check scoring on the ALOA test face used in the shoot-off between Parnell, Gibson and Peterson. Below: Top three archers in the women's unlimited division, Darlene Collier, Mary Lynn Snyder and Eva Troncoso, check scoreboards at the end of the final round.







Rock, Arkansas, did not attend the 1972 U.S. Open because at that time he had little interest in archery. It was only a year ago that a friend sold Gibson his wife's bow and included some lessons in the bargain. After just two months of shooting experience, Gibson won the championships of both Arkansas state associations with 556's and was on his way to Vegas, now equipped with a new Carroll bow.

During the shoot-off we observed Gibson removing his arm guard and tossing it in back of the line. He had just dropped an arrow as a result of hanging up on his arm guard for the second time in the tournament. The first incident cost him a 300. A bad break, but one that doesn't detract from a stunning performance by this newcomer. For frosting on the cake, Gibson scored a Robin Hood on the next-to-last arrow of the first round on his way to a 300.

Blair Peterson is another young man who has it all together despite a minimum of "big-time" tournament experience. An Army officer from Fort Ord, California, Peterson is a study in concentration, and the only shooter to record two 300's this year. Peterson bought his bow, a Bear takedown, at last year's Bear Valley money shoot in California to take advantage of the Team Bear competition. That purchase paid off at the Hawaiian Open where his bow and shooting brought him a second place slot in the Team Bear standings and \$175. But the real pay-off came in Vegas; with this great performance behind him, Blair promises to be a strong contender in the future.

And what of the strong contenders of past U.S. Open tournaments? Well, the foursome that shot clean through the regular rounds last year, Ken Ostling, Bill Mills, John Williamson and

*Top: Pat Norris, Jim Easton, Joan and Terry Shoofey (Misses Archery and Slingshot) during a lighter moment at the Open. Center: Gary Lyman demonstrates the new Carroll Compound Bow and Gary Henspetter takes aim at one of the cleverly-designed targets used in the slingshot competition. Below: A full house watched three shooters under pressure at the shoot-off.*

Rich Slagle, shot admirably this year but dropped a collective 74 points. Indeed, there was no lack of talent and experience on the line, and flights 1 and 2, someone remarked, looked like a listing of who's who in archery.

One man who has long occupied a spot at the top of that list shot his way skillfully and smoothly to victory on the men's limited side of the ledger. "Gentleman Jim" Pickering, of Salt Lake City, Utah, a veteran shooter and archery personality who always seems to turn in a consistently excellent performance, posted scores of 292, 288 and 293 to capture the limited division championship, with his Carroll bow, naturally.

It was not an easy win, however, with Woodside, California's Duane Chaney equalling Pickering's first day 292 and staying right on his heels just two points behind after the second round. Chaney's strong challenge weakened a bit during the final round as he slipped back three more points to wind up with a 868 total.

Meanwhile, coming up strong was Rod Schooler, of Klamath

Falls, Oregon, who strung together steadily improving scores of 288, 289 and 291 to pull up in a tie with Chaney for second place honors. Sacramento, Californian Roger Erlandson, of Frontier Archery, overcame a 282 first round score by posting a strong 288 and 294 to make his bid and take fourth.

Over in the women's unlimited competition, the situation was dominated by some familiar and pretty faces. Darlene Collier and Mary Lynn Snyder picked up their battle where they left it last year, but this time Darlene, the NFAA women's freestyle national champion from Moab, Utah, finished on top with 884.

In the first round, Darlene and Eva Troncoso split the lead with excellent 295's, while last year's winner, Las Vegas archer and hometown favorite, Mary Lynn Snyder, stayed close with a 291. On the second day, Mary Lynn caught fire with a 297 to bring her within one point of Darlene and one point ahead of Eva. Going into the final round, then, it was anybody's contest, but at the end,

Collier had recorded a 295, while Snyder and Troncoso posted 291's.

Eva, incidentally, back in the midst of competition after a long lay-off, shot a beautiful 299 in the ALOA team competition as a member of the Arizona Archery Enterprises Plastifletch entry. Louie Snyder, of Las Vegas, and Jacqueline Sizemore, of Long Beach, California, also finished in the money, both turning in 870's to tie for fourth place.

A tight, two-way contest for honors in the women's limited division saw Midge Killian of Portland, Oregon open a one-point edge over LaVonne Hagemeyer, of Edina, Minnesota, in the first round. Midge shot a 273 and followed up with a 272 on the second day to lead LaVonne by two points. But the final round saw LaVonne turn things around by besting Midge's 262 with a 269 effort to insure first place by five points.

Speak of first place finishers—perhaps the most renowned archer in the world in that category added yet another title to his long list by taking the amateur men's title. Olympic gold medal winner

**FACTORY**

## SCRATCH and DENT SALE

(ONCE EVERY 3 YEARS)

### P.O. CEDAR-F. GLASS-ALUMINUM

HUNTING TARGET

These are high grade arrows being sold at ridiculous prices because of slight damage in production or top grade arrows of discontinued colors or models.

### EVERY ARROW A GOOD SHOOTER

(We destroy all arrows that will not shoot true)  
(or that are badly damaged)

**CEDAR \$3<sup>75</sup> doz. - F. GLASS \$5<sup>50</sup> doz. -  
ALUMINUM \$7<sup>00</sup> doz.**

When ordering give 1st, 2nd, 3rd choice of bowweight and length.  
(Many have F. Points or B.H.A. already installed)

**POSTAGE AND HANDLING EXTRA:**  
(1 doz. \$1.05) (2 doz. \$1.60) (3 doz. \$2.10) (4 doz. \$2.60) (5 doz. \$3.10)  
(6 doz. \$3.55)

## M. J. LOG CORPORATION

1444 JANIE ST.  
BILLINGS, MONT. 59101 - (406) 252-4213



From left, Don and Darlene Collier, Eva Troncoso and Joe Johnston watch the shoot-off during the tense final moments of the tournament.

## ASK JOE

a conversation with the tournament director

*Situation Wanted: Non-English-speaking person desires four days work at U.S. Open in Las Vegas. No knowledge of archery, but willing to learn.*

WE HAVE a position for such a man. He need only learn one phrase in English and we'll put him to work in the tournament information booth. He must be able to answer all questions by saying, "Go see Joe Johnston."

We had a few questions, so we did go to see the tourna-

ment director, who might be described as a man in front of whom the buck often stops. Johnston seemed generally pleased with the tournament — with attendance up 200 from last year, you'd expect him to be — but he already has some changes in mind for Vegas '74.

Example: a main consideration will be some type of stronger program for the top shooters apart from the regular tournament. Currently, the ALOA event consists of four-man teams usually sponsored by various archery houses or manufacturers. Next year's Open

may experiment with two-man teams. Johnston explains why: "I think two-man teams would be easier to get because frequently there are two good shooters coming here from a given area. By putting substantial money into building up a strong two-man evening event, I think we could come up with more people shooting it and hotter competition. The rest of the tournament would remain strictly flights as it was this year."

Will the time limit be subject to change? "We tried to reach a norm to please the majority," he points out. "Seven minutes may be too quick for 50 people, but it may slow 600 people down. Therefore the six minute limit is the logical way to go — and we did. I feel we have to keep the time limit down to fit the majority."

Concern with the majority of archers showed up repeatedly in the format, and in the cash awards. "We did not gear the tournament to the sophisticated shooter who requires more attention for the benefits we

Schettler, of Escondido, and Phyllis Long, of La Puente, took the third and fourth slots with 813 and 805.

Miss Brown also won the Junior Olympic Intermediate Girls competition with a 1066, while Micael Drabek, of Phoenix, Arizona, tied with Gary Riley at 1070 to win the Intermediate Boys title. For the Junior Boys, another Arizonan, Bill Miller of Glendale, won with a 1014, and Heidi Allison, of San Gabriel, California, topped the Junior Girls with a 992.

Cadet winners were hot-shooting Christopher Powers, of Cincinnati, Ohio, who scored a high 994,

*Entertainer Jan Murray, who was appearing at the Desert Inn hotel, watches Olympic gold medalist John Williams. After asking John about the function of the "aerials" on his bow, the well-known comedian turned serious for a lesson from pretty Joan Shoofey, Miss Archery. The Desert Inn staff was most cooperative in helping promote the Open and accommodating the archers.*

get from his being here. Last year we concentrated most on the money in the top championship flights; this year we put more emphasis on the everyday shooter — and there was a very favorable difference in attendance."

Were the bonus awards successful? Johnston thinks so: "We gave away something like 150 lb. of silver dollars. People up and down the line were saying that they might never win another dime, but they were going to keep those silver dollars. I feel this approach was successful."

What about the inside-out scoring, the Vegas Round? "We didn't have any 900's, obviously." Is that necessarily good? "From the standpoint that were a number of top shooters who were, say, five points out after two days, yet didn't feel that they were out of the running," says Johnston. "Last year, with the real top shots shooting nothing hut perfects, shooters who dropped a couple of arrows felt they could never catch up because the top shoot-

ers would continue to shoot perfect. With this round, it was tight enough that the top men might not shoot another perfect — in fact, they didn't. So shooters, a few points out still felt they had a chance. It kept a lot of people competitive."

Johnston thinks it behooves everyone in archery to build a game for archers. An experienced tournament promoter, he has explored archery's possibilities as a spectator sport. His conclusions: "The only way to draw spectators to an archery tournament is to have a spectacular tournament. Let's face it — we can't have it. To sit here and watch someone shoot six arrows is great. But

back to Tempe. Olympian Williams joined with Lambert, Schone and Rolf to capture the amateur men team title with a 2217, and as titles go, the International Has Beens and Will Be's, who were Cook, Hammer, Wilson and Brown, posted 2006 points to win the amateur women's.

As for the open team part of the tourney, California Groves —

Langston, Colombo, Elinbury and Taylor — edged out the Easton Aluminum team composed of Cavallin, Miller, Ostling and Quarles, to win the ALOA top money of \$400 by a three-point advantage of 2373 points.

you'll never get people to sit and watch the archers shoot sixty. We create problems by trying to create things for spectators when we'll never get them anyway. People say we need television coverage. But a sport that is bigger than archery and has a tremendous following, is skeet shooting. Yet I have never seen skeet on television, nor are rifle and pistol shooting televised. Spectators never attend these events in significant numbers."

Johnston explains that archery does need publicity, however, the key is not to attract spectators, but to attract participants. "We are trying to build interest in participating. The area set aside by the Las Vegas Archers here, where people who had never shot could pick up a bow, probably did more for the sport than the actual tournament. Several hundred people were introduced to archery there. What we can hope is that the publicity generated by this tournament will attract people with an interest in shooting."

Cavallin, incidentally, made his first appearance as a pro at a major tourney since he took the

Continued on page 46

**"The key is not to attract spectators, but to attract participants"**







In the winner's circle...

## Gene Parnell

The Sharpshooter from Gillette

GENE PARNELL has been pulling a bowstring for nine years, but the 39-year-old welder from Gillette, Wyoming, was virtually unknown when he appeared at the U.S. Open. There, the "cool cowboy" captured the men's title in a dramatic three-way shootout, and rocked the archery world.

Gene's national triumph came on the heels of a banner year for the bowman. During 1972, he swept the Wyoming archery tournaments, claiming all three of the state's top titles — indoor, field, and target. He was also 1971 state target champ. Then, too, Gene won the Wyoming state-mail-in tournament with an average of 299 over a ten-week period.

Relative newcomer he may be, but Gene has had winning ways ever since he picked up his first bow, at age 31, back in New Mexico in 1963.

Gene started untutored and unknowing, but with an urge to shoot that prompted him to buy his first bow, an inexpensive fiberglass model.

Hunting was what Gene had in mind, and he started by bagging a hear cub. He also began some back-yard plunking and soon progressed to field tournaments around his area of New Mexico. It wasn't long before he was hooked. The more he shot, the more interested he got. He was one of the founding fathers of an archery club in his home town of Artesia, New Mexico.

By 1966, Gene's skill — the man was still without benefit of les-

sons — had progressed to the point that he was able to win the Class B Barebow division at the New Mexico Field Archery Association Target Championship. The archer took his trophy using a 49 lb. hunting bow; a little unorthodox, but successful.

A year later, Gene was at the top of the heap in New Mexico, champion of the Class A Freestyle division in the New Mexico State Target Tournament. By that time Gene had given up his hunting bow, but the new model he'd ordered still hadn't arrived when the tournament rolled around. He won the shootin' match with a borrowed bow.

On Sunday afternoon during the tournament came one of New Mexico's famous rain showers. It just poured for an hour and a half, and all of Gene's feathers fell off; so he borrowed arrows to finish the day. He stayed up half the night fletching arrows so he could shoot the final day, and his efforts paid off in victory.

In 1968, Gene's job took him and his family — wife, Yvonne; daughters, Genie and Diana; and son, Ross — to Seattle. It was in Washington that Parnell got his first real guidance from bow and arrow expert, Terry Call, the bow manufacturer whose product Gene used to win the U.S. Open.

Armed with a new Spartan II, 34 lb. bow, Gene started hitting his targets with more consistent accuracy, and his scores soared accordingly.

In June, 1970, Gene shot his first

perfect 14 field round. After that, everything started clicking. That same month, the vacationing Parnell family stopped at the Northwest sectional in Billings and Gene neatly copped the fourth place trophy and took it back to Washington. Moving to Wyoming in July, 1970, Gene waited a month and then shot his way to a second place finish in the state field championship in Casper.

The mythical archer Cupid must have been looking over Gene's shoulder on Valentine's Day of 1971, because that was the date he shot his first perfect 300. It became the first of many perfect rounds over the next couple of years; they became so numerous, in fact, that the Parnells have lost count.

The honors mounted rapidly. Parnell won the March of Dimes traveling trophy in Rapid City, South Dakota in March, 1971, shooting 299 out of 300. He came in second in the state indoor in March, 1971, in Casper, Wyoming with a score of 585, then went on to win several tournaments around the state. He shot the first 300 ever recorded in Wyoming's state indoor championship in April, 1972.

Gene's first national competition was the National Field Archery Championship in 1971 in Cedar City, Utah. But Lady Luck wasn't exactly with him. He finished a respectable 53rd out of 145 shooters, in Class A Freestyle, but he was destined for greater distinction.

There were to be no other national events until 1973 for Gene, but he did enter the first Rocky Mountain Archery Association tournament held at Denver, Colorado in early December, 1972. It was Gene's first pro shoot. He was a little apprehensive before the tournament started, but at the end of the second practice, he realized it was just a matter of shooting one arrow at a time. He placed second, one point off first place, with a 597.

His next big challenge was the U.S. Open and his performance there is now history.

Indoors, Parnell shoots a 29 lb. Spartan II bow equipped with stabilizer and Chek-It sight with scope. He shoots 1814 X-7's, 28 1/4 in. long, with two-inch Flex-Fletch vanes and quarter-inch Bjorn Nocks. Gene shoots with a release most of the time, a homemade device he designed. Like many hobbyists, Gene builds much of his equipment, makes his own bowstrings and does all of his own work on his arrows.

Parnell also gained experience and knowledge in bow manufacturing working part-time for Spartan Archery Company in Seattle, experience which has been put to good use in tournaments.

A natural shooter, Parnell offers this advice to budding archers: "Stress quality not quantity. Three hours of concentrated practice is far more valuable than eight hours of setting bad shooting habits." Adhering to this principle, the marksman is able to turn out amazing 300 scores practicing an average of only twice a week, about three or four hours at a time.

Since there is no archery center in Gillette, Gene and his shooting partners make use of high school gyms or a backyard target tacked to a few bales of hay. Archery is a family sport for the Parnells. "After all," teases Gene, "what tougher practice conditions could a man face than teaching his wife to shoot?"

Gene may be a newcomer to the national scene, but the cool Wyoming cowboy we watched on the shooting line in Las Vegas is confident he will remain a champion.

## U.S. OPEN SCORES

		Amateur Men			
Name	State	1st rnd	2nd rnd	3rd rnd	Total Prize
1. Williams, John	Ft. Myers, VA	291	292	291	874
2. Rabsca, Don	San Bernardino, CA	292	287	285	864
3. Riley, Gary	Cedar Rapids, IA	290	282	286	858
4. Erlandson, Kevin	Elk Grove, CA	280	288	288	856
5. Folds, Rudy	Vista, CA	272	290	283	845
6. Woody, Ken	Des Moines, IA	280	282	280	842
7. Gorman, Charles Jr.	Glassboro, NJ	280	281	280	841

		Amateur Women			
Name	State	1st rnd	2nd rnd	3rd rnd	Total Prize
1. Brown, Jody	Terrace Park, OH	276	277	279	832
2. Jurn, Carol	Tempe, AZ	274	268	278	820
3. Schettler, Barbara	Escondido, CA	270	269	274	813
4. Long, Phyllis	La Puente, CA	264	271	270	805
5. Plants, Judith	Tucson, AZ	270	271	258	799
6. Cook, Vicki	Crystal, MN	253	265	267	785
7. Smith, Janice	San Bernardino, CA	268	257	257	782

		CHAMPIONSHIP FLIGHT Unlimited Men				
Name	State	1st rnd	2nd rnd	3rd rnd	Total	Prize
1. Parnell, Gene	Gillette, WY	299	300	299	898	\$500
2. Gibson, Ellis	Little Rock, AR	300	299	299	898	\$250
3. Peterson, Blair	Fort Ord, CA	300	298	300	898	\$200
4. Binney, Mike	Phoenix, AZ	297	300	298	895	\$137.50
5. Langston, Tommy	Escalon, CA	299	298	298	895	\$137.50
6. Fulkman, Ron	Fontana, CA	297	298	299	894	\$ 87.50
7. Riggins, Ed	Phoenix, AZ	298	299	297	894	\$ 87.50

		Unlimited Women				
Name	State	1st rnd	2nd rnd	3rd rnd	Total	Prize
1. Collier, Darlene	Moab, UT	295	294	295	884	\$250
2. Snyder, Mary Lynn	Las Vegas, NV	291	297	291	879	\$125
3. Troncoso, Eva	Mont. Park, CA	295	292	291	878	\$ 75
4. Sizemore, Jacquie	Long Beach, CA	290	293	287	870	\$ 55
5. Snyder, Louie	Las Vegas, NV	288	291	291	870	\$ 55
6. Eastman, Betty	Pocatello, ID	283	292	293	868	\$ 40

Continued on page 44

### The Original ALLEN COMPOUND Bow with KNOCK DOWN POWER No Other Bow Can Approach



Mr. Howard Benson, McConnelsville, Ohio

Mr. Howard Benson reports "The Allen Compound Bow came thru like a Champ! I made a shot from about 12 yards slightly quartering away. The arrow entered the Bear's back 6 inches below the spine between the 2nd and 3rd rib. It went thru like a hot knife thru butter and out into 6 inches of sand underneath the bear. Leaving the arrow on the ground the bear took off like a shot for 150 yards, then rolled into a ravine stone dead. Needless to say I am real pleased with the performance of the Allen Compound Bow. It's performance on the Bear indicated that the Compound Bow had a lot more power than the conventional bow."

#### CHOICE OF MODELS

Custom BOW	\$195 <sup>00</sup>	40-50 lb. HUNTER	\$100 <sup>00</sup>
Ladies and Junior	\$100 <sup>00</sup>	50-60 lb. HUNTER	\$135 <sup>00</sup>

Allen's Patent No. 3,486,495  
Licenses are available to manufacturers

Write today for literature and information on models and prices

**ALLEN COMPOUND BOW**  
805-B LINDBERG BILLINGS, MO. 65610  
Telephone - 417 744-2925



Cliff Adams, Trenton, Mo., and 400 lb. bear he shot with Allen's Compound Bow



**Attention! Bow & Arrow Fishermen  
use AL'S FISH-SLICK**



**NO FUSS! NO BOTHER!**  
Shoot with the retractable fishing point with  
the moving barb — 5/16" inside diameter.

**\$1.95 each or 3 for \$5.60**

AT YOUR DEALER OR ORDER DIRECT

**JOSEPH A. BERTE**

7828 W. Lorraine Place - Milwaukee, Wis. 53222

DEALER INQUIRIES WANTED

**We do make very accurate and high quality  
BOW LAMINATIONS**

We have a stock of the best quality hard maple and a hard maple assembly called "Superflex Action-wood," "S.A.," for short. Much of the hard maple is a kind of specially kiln dried wood we have found. It makes excellent bow laminations. The "S.A." maple is very dry, stable and excellent for bow making. Many of the best bowmakers, all over the world, use it in preference to any other wood. Write for price list. We maintain a stock of finished laminations to help us fill orders promptly.

A bow can be no better than the laminations which go into it. We can supply some colorful woods suitable for handle use. We have standard Bo-Tuff (in white, black and forest green). Also Urac glue and bow making instructions.

**THE OLD MASTER CRAFTERS COMPANY**  
130 Le Baron St., Waukegan, Ill. 60085

**CLUB AND ASSOCIATION  
EMBLEMS REPRODUCED**

We are specialists in producing Club Emblem Dies, authentic in detail and club colors. Just send us a rough sketch with size and colors desired. We will gladly advise you as to the least expensive way to produce it.

**64-PAGE CATALOG**

Medals, Pins, Charms, Keys,  
Trophies, Plaques, Jewelry.

Write for Catalog A-71



**MINERO-NEWCOME AND CO., INC.**

251 WASHINGTON ST., JERSEY CITY, NJ 07302

**W-A ARROW NOCK LOCKS**



Arrow Nocked  
Instantly and  
Stays Nocked!

Patent No. 2777437

- Increase accuracy because arrow is always instantly nocked and will stay nocked in the same position on the bow string
- Holds arrow firmly at any desired tension.



Eliminates  
Archery Glove  
by using  
4 Nock Locks  
below Nock  
and 2 above  
the nock

Manufacturers also of W-A Bow-Tip  
Protectors and W-A Brush Knocks!

Write for FREE information.

**WILSON-ALLEN CORP.**

Box 202 WINDSOR, MO. 65360 Tel. 816 647-3125

At the U.S. Open

# The Power of the Mind

Observations on the winning attitudes of champions / by Freddie Troncoso

**THE POWER** of the human mind is such that almost any person can set out and accomplish most any goal providing he makes up his mind and convinces himself he can do it.

What is the difference between a champion and the low scoring middle-class shooter? The sole difference lies within a six-inch span between the ears and is labeled mental control. Success consists of harnessing the power of the mind coupled with an intent and earnest desire to win!

In January I had the pleasure of attending the 1973 U.S. Open Archery Tournament held at the Las Vegas Convention Center.

Driven to the ranks of spectator and/or occasional shooter by a back injury several years ago, I was able to carefully watch and observe the effects of emotional and physical stresses a major tournament of this type creates and how these factors affect shooters of various abilities regardless of shooting methods.

The tournament, under the capable direction of Joe Johnston, went off like precise clockwork. By way of contrast, the erratic vibrations of pressure and emotion emanating from the shooting line were far reaching enough to be sensed and experienced by shooters and spectators alike.

The Las Vegas tournament was climaxed with an exciting three-way shoot-off for first place. All three top contenders, Blair Peterson, Ellis Gibson and Gene Parnell, tallied a 598 out of a possible 600 points scored *inside-out!* The sponsors of the tournament adapted this new and more difficult method of scoring in an effort to curtail the occurrence of mass-perfect scores.

The inside-out scoring simply implies that the arrow must be entirely *within* the higher scoring area, without touching the next lower scoring ring to count as a five. If the arrow shaft barely touches the lower scoring ring, it counts the lower value.

Gene Parnell emerged the winner after shooting six of the deadliest-centered arrows at the new ALOA "par" face I have ever seen shot! I would like to mention the ALOA "par" face has a 1 inch ten-ring, a 2 inch nine-ring and a 3 inch eight-ring which is the maximum size of the gold! Gene totalled a difficult-to-beat 57 out of a possible 60 points scored *inside-out* to win this shoot-off! What factor allowed Gene to perform with machine-like precision during such mental duress? *The Power of the Mind!*

### A Study in Contrast

Two weeks following the tournament, one of my personal friends and fellow archers stopped by to dis-

cuss the tournament. I asked how he enjoyed it, and his reply follows in his own words:

"Freddie, the tournament was great but I never recall having spent three more miserable days in my entire life. I was so nervous I could hear my own knees knocking together and my heart pumping so hard I thought it was going to jump out of my chest. I went to Vegas to win, or at least shoot my average. Instead, I fell totally apart like a cheap watch and lay there in a heap while people walked over me, unable to get up for love nor money!"

The difference in performances of these two archers can be attributed solely to mental control and lack of confidence. *The Power of the Mind* can work for you or against you.

Man has invested more time and money in an effort to study the human mind during the last decade than at any other time in history. Science has made tremendous advances and discoveries concerning human behavior dealing with the self-image.

The self-image simply refers to a mental picture of the type of person you perceive yourself to be. You may see yourself as a success or failure, good-looking or disfigured, dumb or inadequate. The things people say to you and the events that happen in your life also help you to make an assessment of yourself. However, the assessment need not be totally and completely correct. It may be completely erroneous and incorrect!

This self-image evaluation can make you a success or a failure. It can make you a good archer capable of shooting high scores or a mediocre or low scoring archer. I have repeatedly heard archers say, "I'll never be a good shot, I'm only here for a good time" or "I'll never break 250 indoors, I'm too old to keep up to the younger champions." Baloney! These archers are mentally defeating themselves!

Every act man performs should be directed toward the successful accomplishment of a particular goal. Man is by nature *goal orientated*. The archers who say they cannot do better also have a goal in mind. This goal is the successful achievement of failure.

*Author's wife, Eva, back after a decade's lay-off from archery, powered her way into the top three women's standings in Vegas.*



### Successes

All learning is accomplished by remembering your successes and forgetting your failures. It is this knowledge that will enable us to improve our archery. If you have experienced shooting top scores in practice and at local tournaments, there is no sound reason for falling apart at a major tournament.

Think back for a moment to the time you were learning to shoot a bow, drive a car, or any other activity requiring muscle coordination. As you learned to perform one of these acts, you remembered your successful performances and forgot the times you failed, did you not? The sole purpose of practice is to learn a muscular skill both physically and mentally.

Once the mechanics of a particular skill are mastered, one should be able to proceed "automatically" such as one does during the process of walking. If you think of going to the next room to get a dictionary, you do it without giving any thought to the mechanics of walking. In other words, you proceed automatically with solely the goal of picking up the dictionary in your mind. The same parallel exists while learning the fundamentals and mechanics of shooting.

Once you learn how to shoot, your entire mental efforts should be concentrated entirely on aiming and holding the pin dead center-of-center as best as humanly possible. If you have not mastered the basic fundamentals before going to a major tournament, do not go there expecting to find or master same during the tournament.

### Control is Practiced

As I walked up and down the shooting line at Las Vegas, I watched shooters in *all* divisions mentally fighting the inner involuntary urge to release. To my amazement, several world renown name archers flinched and let down which, in my opinion, reflects common sense and mental control.

How do these archers acquire the mental control and get over the nervousness of being watched, you ask? The answer is many hours of practice, many hours of competing in league play and, above all, attending as many major tournaments as possible. If you really want to win, you have to shoot, shoot, and shoot, creating your own tournament conditions if necessary.

The aspiring champion must mentally acclimate himself to being watched and shooting under pressure by developing concentration to such a degree where he only sees the target and the target alone! It takes a champion an average of two years of intense shooting to become tournament hardened and get rid of "butterflies" or tournament jitters. Remember all good shooting is practiced and all practice should be conducted as if one is competing in a major tournament.

There are no short cuts to success, only hard diligent work and a desire to succeed. If you possess these qualities, anyone can turn the trick providing you let *The Power of the Mind* work for you!



## Check your equipment choices

THE HUMAN animal is usually so bound by external circumstances and habit that he finds it hard to think objectively. The bowhunter, as a case in point, often rationalizes his choice of equipment because he hasn't tried, or can't afford, something new on the market. Those of us who have been bowhunting for many years have a third hangup, sentimentality.

In order to come up with a really objective (but personal) appraisal of the best bowhunting gear, here's what I assume has occurred.

First, all my existing archery and hunting equipment has been totally destroyed.

Second, some benefactor has offered to underwrite the cost of an entire outfit, including clothing, with no ceiling on cost.

In other words, I could buy whatever I wanted in the way of bowhunting gear regardless of cost. The only criteria would be to get what I really wanted and thought best for the job. To begin this shopping spree I've prepared a list of what I'd select. Here's that list sorted into three categories — basics, accessories, clothing. The list represents what I'd pick for myself if presented with this Utopian situation.

### The Bow and the Arrow

The bow would be a compound how, adjustable in the 55 to 70 lb. range, no question about it. I've been using one for five months (at this writing) and it is to me at least, without any question, a superior hunting bow. Here are some of my reasons:

- At a given peak draw weight the arrow has a flatter trajectory and better penetration;
- At full draw it can be held longer;
- It is short, sturdy, quiet, and it can be taken down.
- Replacement parts permit repairs in the field.

What more can a bowhunter ask? It isn't as pretty as a recurve, that's for sure; but as someone else has noted "beauty is in the eye of the beholder." To me that arrow streaking silently from the bow is beauty enough. After all, the archer should respond more to the flight of the arrow which he sees than to the bow which he doesn't see when he shoots.

Aluminum arrows would be my clear-cut first choice. I'd pick the toughest, hardest shaft made with an anodized green finish for camouflage purposes. The business end would be equipped for changeable points — matched field, blunt and broadhead. The other end would have pinch-type nocks to grip the string and a four-fletch of red and yellow feathers, 5x9/16 inches, angled on a straight pitch of 3/32 inches. Four dozen would be the minimum number for year-round use. In addition, I'd want four to six dozen "throwaway" shafts for fun shooting. Other



Author Sage, well-equipped for a bunny hunt.

than having them reasonably matched, the specs on these "fun" arrows would not be too critical.

### The Accessories

Since accessories have already been defined as excluding only the bow, arrows and clothing, a lot of ground has to be covered. Eliminating mention of incidentals like wax, glue, extra strings, etc., let's further break this group into archery accessories and hunting accessories. First, the archery items:

- Bow quiver that attaches as an integral part of the bowhandle.
- "St. Charles" type back quiver.
- Camouflage paint job on the bow and the quiver.
- Adjustable "pressure point" with teflon button for the bow
- "Spare parts" kit for the bow including cables, pulleys and an extra bow limb
- Rigid bowcase capable of holding the bow with the bow quiver attached
- Four dozen changeable broadheads with razor-type inserts
- Arrow straightener
- Fletching jig handling six arrows at once
- Side quiver for practice use
- One arrow case to hold one dozen arrows
- Two arrow cases, each for two dozen arrows

The principal hunting accessories would be:

- Lightest, most compact 7x35 binocular made
- Wrist compass
- Bustle pack with canteen
- File and a sharpening stone
- Waterproof match safe and whistle
- Folding knife with a 4" blade

### The Wardrobe

The hunting clothing list could go on and on, so only the critical items in a well-balanced wardrobe are listed:

- One pair canvas-faced brush pants
- Two pair medium weight, hard weave, wool pants — forest green
- Two pair cotton camouflage pants
- One pair lightweight rain pants, forest green or camouflage
- One light weight wool shirt
- Two medium weight wool shirts
- One down vest
- One tight weave, wool "jack shirt", forest green
- One lightweight, tough poplin jacket, forest green
- One lightweight rain jacket with front zipper and hood, forest green or camouflage
- One cotton camouflage jacket
- Two sets medium weight, waffle weave long johns
- Six pair rag wool socks, nylon reinforced, ten inch height
- Six pair light weight wool socks, nylon reinforced, ten inch height
- One pair lightweight 6" hiking shoes (not Vibram soled)
- One pair medium weight 6" hiking shoes (with Vibram soles)
- One pair leather top, rubber bottomed 12" "shoepacs"
- One pair cold weather "shoe pacs" with felt liners
- Two hats for mild and cold weather, "Jones Style" camouflage
- Two pair of gloves (wool with leather faces).

The foregoing, then, is what I'd buy if I were starting from scratch with an unlimited bankroll. No item was included not deemed important to the type of hunting I do, but no item was excluded nor was any "second-best" choice made. I estimate the outfits listed would cost close to \$1200.

Not surprisingly, a check of my tackle closet shows many of the above-mentioned items are already in place. My binocular is a bit heavier than desired but still highly serviceable. I don't have a spare bow limb, but I do have a spare bow; my arrow inventory isn't up to par as far as aluminum arrows are concerned. While none of these deficiencies are critical, I am on the way to rectifying the latter two.

The purpose of the foregoing drill is two-fold. First, it's a list developed from extensive personal bowhunting experience and as such, it should be helpful to the archer contemplating new equipment or an extended hunting trip. Second, developing such a list is one way of really thinking objectively about the subject.

You need the best equipment you can get for serious bowhunting, yet you'll often try to save a few bucks and settle for a second-rate item. This very item, however, could make or break a hunting trip costing as much as the entire outfit. Should it fail at a critical moment it would be hard to forgive yourself.

I'd be willing to hunt anywhere in North America with the equipment listed, confident of being able to hunt effectively and comfortably. You should make your own list to be sure you haven't been fooling yourself about your tackle. It could add enjoyment to your trips and put a trophy on the wall.

## BRUSH BUTTONS®

Brushproof Any Bow

Dampen String Noise

SUPERS . . . . \$1.00 Per Pr.

STANDARDS . . . .90 Per Pr.

## STRING SILENCERS

KILBEAD'S®

Kills String Noise

\$1.00 PER PR. Convert high frequency noise into a whisper instantly.

## NOCK LOCATORS

TRUESPOT®

"Instant Mount"

\$1.00 Per Pr.

Large or small string size

Spots your arrow exactly — every shot. Will NOT roll string. Gives extremely accurate "Hair Trigger" release. Arrow may be slipped up or down until it seats in notch. Mfg. of light weight SOLID NYLON. Can be used over and over.

No sticky compressible rubber surfaces here!

## FEATHERS

Lowest Price.

WRITE FOR PRICES and SAMPLE

Highest Quality Fastest Service

Will NOT squash or deform on draw.

Will NOT move when properly installed.

Shield Style  
Parabolic Style

Full Length or Die Cut

Archery Necessities & Accessories  
**TRUEFLIGHT**  
MANUFACTURING COMPANY, INC.  
MANITOWISH WATERS, WISCONSIN 54845



Across Colorado  
in pursuit of  
the wiley muley  
and Lady Luck  
by Richard Schreiber



# Bad Breaks on the Best of Bowhunts

THE MULE deer was about 250 yards away but he was loping toward me completely unaware. Crouching down with raised bow I waited as an eternity seemed to pass before the forked buck was close enough for a shot.

Close enough, then still closer he came; in my mind I wanted to shoot but the fingers wouldn't respond. Thirty yards, twenty-five, twenty and still no response from my fingers, they seemed to know the closer the shot the better.

Suddenly the deer pulled to a halt at ten yards. Two aspens made a nightmare of this dream-like situation, for all that showed were the deer's floppy ears. Slowly I leaned to the right hoping for a standing shot around the trees.

Our eyes met and he bolted; swinging broadside he started to go around me. My release and the arrow's flight seemed perfect, but the brief moment of perfection was rudely interrupted by a loud smack as the broadhead hammered into an aspen.

I had blown my first shot at a mule deer. Little did I realize that this memory would haunt me throughout the coming year until I could return for another reenactment.

My interest in a western hunt had been aroused by a friend just back from bowhunting in Colorado. It would be so easy, hadn't he said; "the shots are longer, but they're open." Three Colorado



Above: One of many ideal tree blind sites, this one near a waterfall. Below: Some stillhunts end with everyone walking up to the vehicles. Plenty of rests are in order at the high altitudes.



bow seasons have since passed and each year I've marveled at the splendor of an August sun poking its crimson rays between mountain peaks early on opening day. A great many shots that seemed plenty clear have been lofted, but this mythical "open shot" certainly has eluded me. I have had undeflected arrows but they were beyond my 50 yard accuracy range.

## All the Excuses

On closer mule deer shots I have just about used up all possible excuses. The one excuse that I haven't and hope never will use is the easiest to avoid, equipment failure. A flatter shooting bow than my 48 lb. Bear Grizzly might have helped, but the confidence I have developed in it has been borne out by the seven whitetails it has taken.

The first year in Colorado I hunted with Bob Morrison and his associate, Jerry Byrum. For two days I hunted seeing only does and fawns. Mostly I just walked around and admired the mountains.

My first big chance for a mule deer was the one mentioned above. We had been moving along a mountainside on an organized stillhunt. The drivers were spread out at fifty to sixty yard intervals, while standers were positioned at known crossings. The drivers moved slowly, two or three steps at a time, at each pause looking around through the trees as far as possible, eyes straining for the motion of an antler tip, a tail flicking, an ear twitching, or a flash of brown.

Many times you can spot mule deer several hundred yards away when you know what to look for. The concept of looking past the trees was a hard one for this white-tail hunter to grasp after being used to seeing deer at 70 yards.

My one miss had been the big event of the first year, but by mid-winter the memory of it was working on me. When three friends and I heard that Jerry Byrum was outfitting on his own we knew he was our man. His hard work, bowhunting knowledge, and willingness to go all out for his hunters had thoroughly impressed the three of us who had hunted with him the year before.

We sent our letter to Jerry, asking for brochures and in a few days we were all studying his different types of hunts. Due to lack of storage space, we decided on the regular hunt. We supplied our personal gear, license (non-resident \$25), and sleeping bag, while Jerry supplied the guide service, tents (with plywood floors, it turned out), cots, and prepared meals. The economy hunt includes only meals and guide service.

Our \$50 deposit was sent in, then it was wait, practice, and talk about the hunt. We read and re-read the brochures, underlined the things that interested us: elevations 7,000 to 9,000 ft.; temperatures from 25° at night to 75° at mid-day; shots from five to 50 yards — and most important

— approximately 35% of the heads in the Boone and Crocket record book came from Colorado.

The weeks dragged but finally we found ourselves in Jerry's secluded camp in the Grand Mesa National Forest. The first day's sunrise was great, but the buck browsing 50 yards away distracted me immediately. It was feeding and slowly angling away. Things were perfect for a stalk. The breeze was in my face and the deer was oblivious to my presence, oblivious until a sudden wind shift. I should have noticed the change and tried a 45 yard shot, but the buck ran off with my bow undrawn.

The second day we were making a little push before taking evening stands. The bobbing of antlers 20 yards below me on the mountain caught my eye. Thick brush screened the deer's body, so I paralleled the deer's movement until a clear path through the brush appeared. I drew back partially and waited. The deer made the opening and quickly turned toward me.

## No Spot

The antlers waved over its spine and its nose was down over its chest. It came on. A perfectly centered hit on its tilted head would probably glance off. There was *no spot*, wouldn't you know it.

The deer came closer, unaware that I was near, but a pine branch now screened the big four-pointer. When it reached the branch I decided to release. The deer was milliseconds from the release instant when it whirled and took off. I panicked and blew a wide open running shot at 25 yards. Had I frightened the deer by blinking in anticipation of the shot? Had the deer winded me, or had I moved an elbow? I'll never know.

The whole week was one of "I didn't's." I didn't stay in line on one push and a big buck went through the vacated hole. I didn't swing wide enough as end man on another drive and only a glimpse of two bucks breaking out of our pincer action was my reward.

The "I didn't's" were again evident on the last afternoon. I decided to resist the temptation of the ever-present hot coffee in

camp to try a stillhunt on my own while the others rested before going on our last chance stands. Jerry dropped me off, agreeing to pick me up in two hours.

Two hundred yards into the quakie (aspen) and pine-blow-down mixture, I moved out a big deer that didn't seem too alarmed. Hoping it might pull the not unusual trick of out-flanking and getting above me to look me over, I decided to beat it at its own game if such were the case.

I raced as fast and as quietly as possible uphill to a nearby crest of land. Near the top the path was blocked by a blowdown. Plowing through it would be too noisy, so a detour was the only answer. Off



Bill Pazen with his record book buck.

the path going was slow, I didn't get around fast enough. Topping out I saw the approaching deer spin into thick cover too fast for a shot.

Moving on into a park-like little valley of scattered quakies with a few pines and knee-deep grass I accidentally walked up on the biggest buck I was to see on the whole trip. He was laying under a spruce. At 15 yards he came boiling out heading straight away with the tree as a shield. Stepping clear, I shot. The "buck didn't" follow the lead; at the last second he veered to the right.

Rain was starting to fall just as Jerry picked me up. Jerry had his poncho on one of the few times I've ever seen him wearing it because usually some forgetful hunter gets it. The rain turned into a downpour lasting until dark washing out our last chance stands and





Bill Pazen (left) and his deer with Norm Moss helping to hold the 33 in. rack for comparison with Bill's bow. Jerry Byrum (kneeling) anxiously waits to get the deer out of the Bronco and into cool shade.

my second year of hunting mule deer.

A third consecutive Colorado hunt was in jeopardy due to job changes and school conflicts until a lucky meeting at the Milwaukee Sport Show with Norm Moss, whom I had met the first year in Colorado. Norm and two friends needed a fourth man to share expenses. With Norm's pickup camper giving extra storage space we decided on Jerry's economy hunt.

#### New Area, New Chance

Jerry had switched camp to the Uncompahgre National Forest. His summer scouting had turned up an area loaded with deer and better suited to bow-hunting than the Grand Mesa area. He told me my thoughts of trying more of the stillhunt-stalk type hunting would be well suited to the area. I could just picture myself spotting a mule deer several hundred yards away, then putting on the old storybook stalk.

Standing and then stillhunting back to camp was on the agenda for me opening day if it ever stopped raining. On Friday afternoon Jerry had to go back to Grand Junction to pick up some late arriving hunters. One hour before daylight on Saturday morning Jerry still wasn't back in camp. The all night rain had made the mountain roads a quagmire.

The rain stopped though and the stars were starting to poke through when I began walking to my stand. Jerry and his assis-

tant, Bob Hughes, met me just outside camp. The late arrivals had not shown up, and Jerry and Bob had been on the road and in the ditches all night trying to get back to camp.

I drew a blank at the waterhole stand and decided to follow the plan of hunting back to camp.

I drew a blank at the waterhole stand and decided to follow the plan of hunting back to camp. Just when I was beginning to think there were no deer on the mountain, a doe appeared out of nowhere ahead and above me. Up popped a buck's head and I was in business. The fuzzy antlered 4x4 was completely unaware of my presence, but the doe was suspicious. The two deer fed slowly along with the wary doe gazing my way occasionally. My scent was rising so I dropped back to get above and behind them.

The doe suddenly ran into thicker cover lower on the mountain but the buck kept on feeding. By the time I worked my way above him, he had opened up a big lead. Seeing a little ridge to use for cover I went into action cutting down the distance. Slipping up the ridge I peeked over. He was gone, just disappeared. Although I looked, and looked, and looked, he had simply vanished.

I met the others at camp. They were on their way to set up the second stillhunt-drive of the day. I was selected to be one of the standers. Forty minutes passed and nothing, when a high-racked buck and a doe raced past me at

70 yards. I lobbed an arrow but was behind the running deer. Later I learned that several hundred yards away Bill Pazen, one of the foursome I came out to Colorado with, was shooting a record book muley about the same time I was missing the long shot.

Next day I was on my own again. The only action was a small buck that jumped the string and I was nearly back to camp when I saw a deer on the side of a ridge. I decided to try a stalk even though I could not identify it. The ridge turned out to be a hogback. I made it to the top and looked over the side, nothing. I zigzagged back and forth carefully looking over each edge. At the last hidden point not 20 feet away a doe was browsing on twigs. My heart dropped, but just as it did a buck walked out 30 yards away almost straight down.

I drew back and waited for the buck to clear an obstructing bush. The arrow was just right but for one thing, it hit a dead branch that came out of nowhere. The arrow plowed into the path under the buck sending him up the trail at a fast trot.

I drew another arrow just as the buck turned and starting walking back toward me and the now fleeing doe and another previously unseen deer. The buck decided this was wrong; whirling, he started going away again.

#### Another Branch

I released and wouldn't you know it, another branch. The arrow charmed away missing by several yards beyond and behind the deer. The buck now hit a higher gear but as he did he turned away from the last arrow's sound. Broadside up the hogback he came passing me at 55 yards. I got off two more shots, both high.

It started to rain just as I arrived at camp; soon marble size hail was falling. The only one in camp was Jack Johnson, Jerry's cook. He had the usual hot cup of



Horses were available and a great help for packing and getting into deep canyons.

coffee ready. Two cups, two cookies, and three apples later it was still raining. I took a nap. The rain was stopping just as other hunters began straggling into camp.

The vehicles were having a tough time of it on the greasy roads and many of the hunters decided to walk to camp even though it was six steps and scrape mud all the way.

Only five shots had been fired all day and I had taken them all. Spirits were down until supper, Jack's chicken, potatoes, green beans, and tossed salad supper had done their job. The campfire that night under a star spangled sky never felt better.

My first night on stand had been exciting. There were from six to thirteen bucks in a large meadow by my waterhole. Due to the rolling terrain I never had more than six bucks in view at one time so some were possibly counted twice.

The second evening found me on my portable stand where the deer had entered the meadow. The wind was cold and blowing hard. Three deer came out at dark but the

gloom and distance prevented identification.

The third night's weather was perfect, exactly like the first evening when I had seen all the bucks. I checked my watch, it was time for the deer to show up. Within minutes two small bucks were working their way up the trail. Just right, the smaller deer had preceded the larger ones the first evening. I had decided not to let them get out of range, for if nothing else showed behind them I would attempt a shot at them.

The deer seemed to nibble on leaves as they kept glancing back just as before. My heart was racing, I had to force myself to be calm and think, *pick a spot*.

The unbelievable happened, the deer turned at 50 yards and staying in the cover of the trees they paralleled the meadow and disappeared. The reason for their strange behavior appeared, I almost cried. Another bowhunter, one not from our camp, came out to the meadow's edge right under my stand. I never said a word and he didn't see me or the deer by the way he acted.

The last chance for a deer was before us. The drivers had a long walk to set up the hunt. On the long ones Jerry usually takes volunteers to drive so if you're not in fair shape you can elect to take a stand. I knew the 3¼ miles a day I had worked up to while running all summer had paid off. The last day had found me very tired and much less alert in other years.

The last push was minutes old when I caught a flash of brown below me in the underbrush. Five bucks crossed an opening. The last and largest stopped with only his front shoulder exposed. At 60 yards the shot seemed to be engulfed in the trees. The cowap that echoed back up the mountain sounded real good. Wrong again, the arrow was deep in a rotting stump.

Moving slowly down a point of land I glanced back in time to see a rack of velvet poke up through the brush. His body was hidden though he was only 12 to 15 yards away. He was going to drop out of sight any second when his outline became clearly visible. I drew quickly and shot. The fates were against me, another miss. Al French, my other hunting partner, had hit a nice four-pointer right in an antler. The buck had taken off like a streak.

The third year's hunt was over. I've been learning more every year about mule deer and maybe, just maybe, year number four won't need any excuses.



## PATCHES

Since 1941, we have offered fine embroidered emblems at low prices. For quotation, send sample or sketch and indicate quantity required.

FRANK J. WAHL COMPANY  
Box 219-FA, Teaneck, NJ 07666

## PACIFIC ARCHERY

Finest quality Port Orford Cedar arrow shafts.  
Hand spined. State size.  
Wholesale price list on request.  
P.O. Box 209,  
North Bend, Ore. 97459

MID-NOX - FEATHERS - PORT ORFORD CEDAR SHAFTS  
CARLISLE LEATHER - BOWSTRINGS (Large Stock)  
EASTON SHAFTS - MICRO-FLITE SHAFTS - BIGAME  
BROADHEADS (Fit 5/16" or 11/32") - HI PRECISION  
BROADHEADS - X-7 SHAFTS & ARROWS (to X-7 dealers only)

## WEST VIRGINIA ARCHERY SUPPLY

616 Chestnut Street, South Charleston, W. Va. 25309  
Phone: Code 304, Number 768-6091



# How to shoot instinctively—and win

Bowhunter Bob Walker bares all the scientific secrets of champions in his humorous explanation of the gap system.

WELL, the proverbial cat is out of the well-known bag. Probably a large percentage of archers at one time or another have wondered how in the world those of us who shoot instinctively can hit anything.

Questions have been asked: "How do you aim? What is your aiming point? Where do you hold?" Now I felt very smug and secure in the misbegotten notion that we knew a secret that freestylers — stringwalkers are also freestyle, whether they know it or not — did not know. Not so at all. Was I ever wrong!

Last summer, on one of our local ranges, I overheard an otherwise well-informed young man (with a strange looking tab on his hand) lightly dismiss the phenomenal accuracy of our NFAA National Bowhunter Champion with a wave of the hand and the sage comment, "Oh, he just uses a gap system".

You can imagine my dismay — he knew! So, since the secret is out, I shall explain this system, and we can all shoot well.

The beauty of the gap system is its utter simplicity. A knowledge of high school trigonometry is all you need to use it. No sophisticated physics or angular velocities or anything like that is required; just plain old horse sense. Ready? Here we go.

First step: measure your arrow from nock to tip, and the distance from your eye to the nock at full draw. See the diagram below, with my measurements as an example.

Bowhunter Champion Cal Vogt: "Is that how he does it?"

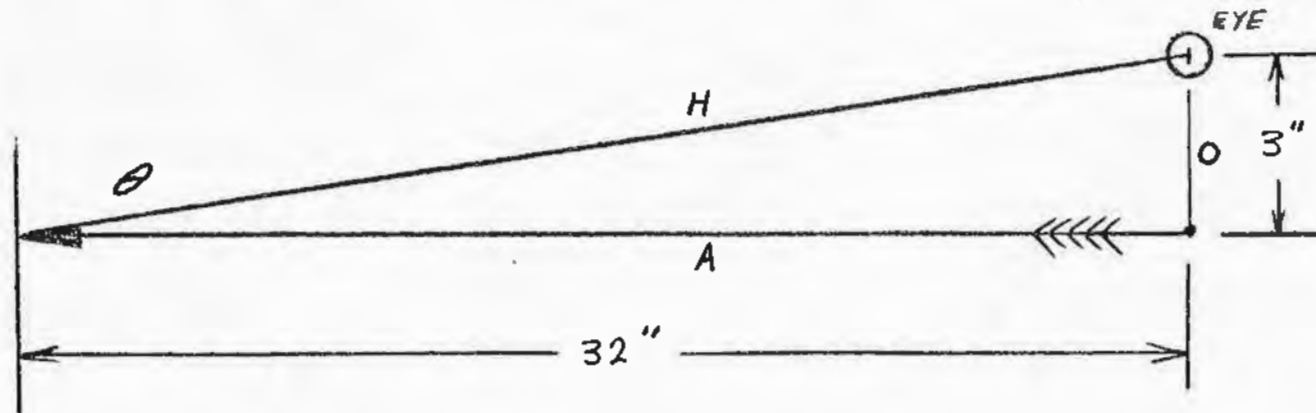

Note the lines forming a right triangle and side designations. We know two sides,  $\theta$  and  $A$ . Therefore, from elementary trig, we can determine angle  $\theta$  by  $\theta = \text{Arctan } \theta/A$ . In the example this angle measures 5 degrees and 21 minutes, and by simple conversion we know that this is about 5.35 degrees. Calculate your own angle and store this figure in your mental memory bank as you will use it often.

We shall now extend these lines to the target as shown below in the second diagram which is expanded and obviously not to scale for purposes of illustration.

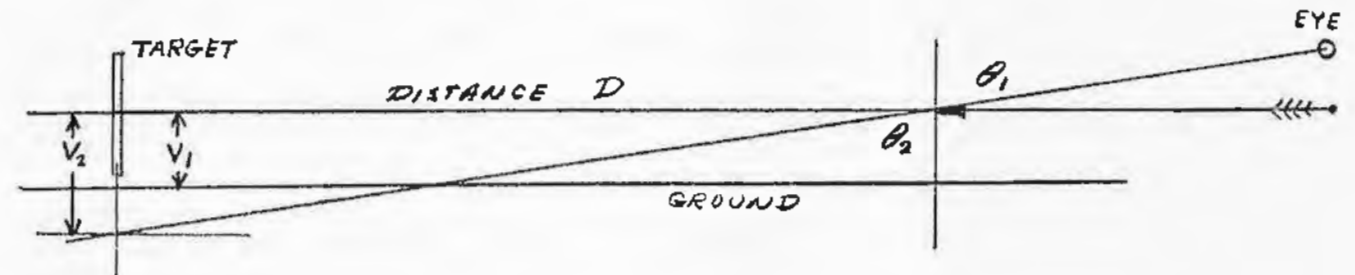
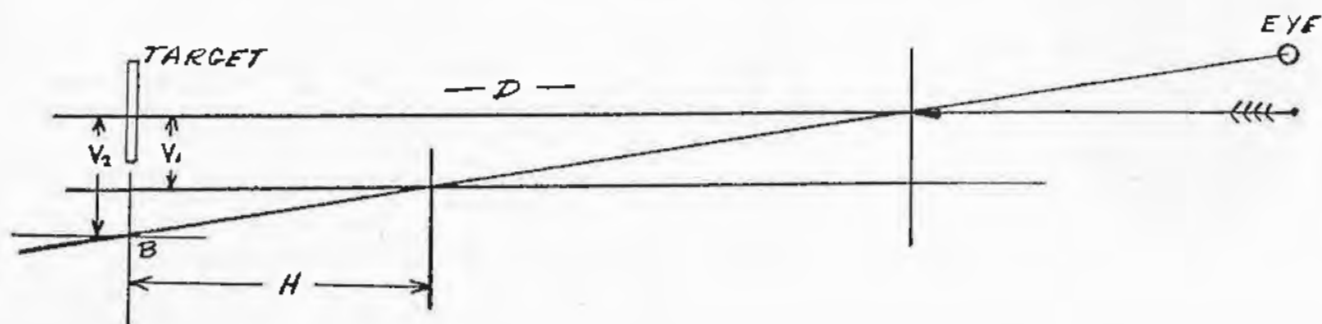

Since the below ground gap is known (13 ft. 4 in.), and we know that included angles of a right triangle must equal 180 degrees, angle  $B$  can be found by subtracting your angle (the one you memorized) from 90 degrees (distance  $D$  and the target plane  $V_1$  are, of course, the other 90 degrees). From our example 5.35 degrees from 90 leaves us with angle  $B$  being 84.65 degrees. Now we have two known values and since  $H = (V_2 - V_1) \text{ Tan } B$ , we arrive at horizontal distance, or valid gap. Prior to some minor corrections (for trajectory, horizontal plane disparity, and wind)  $H = 141 \text{ ft. } 7 \text{ in.}$  (approx) target to point of aim.

By now some questions may have arisen concerning trajectory allowance (always subtract) and the fact that the center of the target is not always on the same horizontal plane as your arrow (correction may be plus or minus). Do not despair. These miniscule thorns in your side will be taken care of by your mental logic system in a very short time. The ability to start with a known gap is most important (answers for all conditions are calculable, of course, but the equations are somewhat beyond the scope of this article).

So there you have it, the gap in a nutshell. Simply determine target distance, quickly calculate your horizontal gap, judge that distance from the target, place your arrow tip on that spot (you must watch this point carefully, never mind the target, you can see it when you pull your arrows), make your final minor corrections and zip into the five ring it goes. Calculations need take no longer than counting servings, and if your shooting partners get impatient, give them this article to read.

Champions are just men like everyone else, and if this system seems momentarily tiresome, notice sometime how quickly, easily and effectively the remarkable Cal Vogt does it. Even in the dark! All we bowhunters do it, don't we? So I'm often told.



"Now to allow for horizontal plane disparity..."



**NATIONAL FIELD  
ARCHERY  
ASSOCIATION**



Route 2, Box 514  
Redlands, Calif. 92373  
(714) 794-2133

**NFAA OFFICERS**

**Ervin G. Kreischer**  
President  
827 Floretta Dr., N.W.  
Albuquerque, New Mexico 87107

**John W. Durham**  
Vice President  
2604 So. 19th St.  
Ft. Pierce, Florida 33450

**E. Pat Wingfield**  
Immediate Past President  
976 W. Alisal, Apt. 2  
Salinas, California 93901

**Wm. H. Wadsworth**  
Bow Hunting Chairman  
Boy Scouts of America  
New Brunswick, New Jersey 08904

**Ervin W. Belt**  
Executive Secretary  
Route 2, Box 514  
Redlands, California 92373  
(714) 794-2133

**BOARD OF DIRECTORS  
COUNCILMEN**

*New England:*  
**Bradlee V. Starrett**  
460 Massachusetts Ave.  
Lunenburg, Massachusetts 01462

*Southeastern:*  
**Ramsey Cutshall**  
1000 E. Church St.  
Greenville, Tennessee 37743

*Mid-Western:*  
**Bennie Mooer**  
2600 Williams  
Great Bend, Kansas 67530

*Great Lakes:*  
**Roland Mantzke**  
1260 Constellation Drive  
Aurora, Illinois 60505

*Southern:*  
**Gene Colteaux**  
Rt. 4, Box 86  
Longview, Texas 75601

*Northwestern:*  
**Jerry L. Brabec**  
4548 Stone Ave.  
Billings, Montana 59101

*Southwestern:*  
**George Chraft**  
6113 Fairwood Cr.  
Las Vegas, Nevada 89107

*Mid-Atlantic:*  
**William E. Boyle**  
Ontario St. Extension  
Canadaigua, New York 14424

**POINTS** / by **ERV KREISCHER**

# Enthusiasm over

*Good news for archers from Washington,*

**E**VENTS of the first two months of 1973 have brought cause for enthusiastic optimism! At the top of this list of events is the decision by the United States District Judge, Charles R. Richey, to dismiss the suit brought by the Humane Society of America against the Secretary of the Interior and the International Association of Game, Fish and Conservation Commissioners.

The suit asked a permanent order enjoining the Defendant Secretary from conducting three public deer herd reduction hunts in the Great Swamp National Wildlife Refuge of New Jersey, the Eastern Neck National Wildlife Refuge in Maryland, and the Chinoteague National Wildlife Refuge in Virginia.

The hearing began on February 7th. A prepared statement by the defendant refuted the charge that it is improper to allow public hunting as a recreational activity within a National Wildlife Refuge and asked the judge to dismiss the suit. Judge Richey agreed and dismissed the action on February 8th.

What does this mean? It means we have won *round one!* It is likely there will be an appeal. It is also likely other test cases will be filed

in other areas of the nation in situations which appear vulnerable. In the meantime, we've got to keep our powder dry and our Defense Fund, up!

Having pledged the total amount to assist in the Washington hearing left the fund depleted; but, not for long! To demonstrate how serious your NFAA Bowhunting and Conservation Committee is in this cause, they pledged \$500.00 to the National Bowhunting Defense Fund and passed around a collection plate during the banquet program at the recent NFAA Board meeting in Portland, which gathered another \$350.00.

But, this is only the beginning! The following day brought a motion to transfer to the Defense Fund money which is being held in a Headquarters building fund. It was unanimously approved by your Board of Directors. Should the individual contributors to this building fund agree, it would add a sizeable amount to the Defense Fund.

Contributions from state associations, clubs and individuals are being received at Headquarters in each mail delivery. This is a tremendous tribute to the NFAA and demonstrates that we are,

## Bowhunter Defense Fund Grows

At the recent National meeting in Portland, Oregon, Bill Wadsworth, Chairman of the Bowhunting Committee and Dr. Jim Shubert, a member of that committee, contributed a total of \$500.00, which represented a portion of their travel expense refund. In addition, members in attendance at the annual banquet, contributed a total of \$350.00.

Other contributions received to date from individuals, clubs and/or Associations are:

Illinois Bowhunters \$168.00; Virginia Bowhunters Assoc. \$100.00; Rochester Bowhunters Club, \$100.00; Auroraland Archers \$25.00; Sioux Whasky Bowhunters \$25.00; Ervin G. Kreischer \$20.00; Bill Wadsworth \$20.00; Robert H. Puhl \$10.00; L. Scott Keller \$7.00; Arnold Silva \$5.00.

A sincere thanks from the National Field Archery Association, its officers, and especially the Bowhunters, to these contributors. The fund at present, which includes that portion allocated from the Bowhunter Membership fee stands at \$1,871.00.

# recent events

*Las Vegas and Portland*

indeed, ready and willing to stand up and be counted!

The 1973 Las Vegas Open was one of the finest indoor events I have been privileged to attend. Attendance was up more than 200 entries over 1971 and 1972. The \$1,000.00 Special Award Fund for NFAA members was our first involvement in this fine event since we gave up managing the tournament, back in 1962.

This \$1,000.00 award was made possible because several NFAA members deposited that amount to guarantee the award. Confidence in their belief that NFAA members would support this promotion was substantiated. The event showed a profit of more than \$100 which was donated to the NFAA. This promotion by our members, in behalf of the NFAA, is one of the most refreshing assurances I have witnessed in modern times. I offer my personal appreciation to those members who donated their time and risked their money!

The eighth annual meeting of the NFAA Board of Directors was held February 2, 3 and 4 at Portland, Oregon, and has to be one of the finest on record. I left Portland with more enthusiasm than I had brought. I got the feeling that most of the Directors and Councilmen shared my emotions. Since details of the newly adopted programs and changes will appear in other articles, I will comment only briefly on items I consider to be highlights.

1. A NFAA Professional Division was established. Archers of this division will compete for cash prizes and will not be in contention for titles or trophies of other divisions. There is much enthusiasm for the division and more than 80 members have already joined its ranks.

2. A travel fund was included in the budget to provide finances to send our top man and woman barebow archers to compete in the In-

ternational Field Archery Association World Championships which will be held in England during July. The selections will be announced at a later date.

3. The Board re-affirmed its stand in regard to shooting equipment regulations, i.e., compound bows are legal in all divisions and release aids, in freestyle only. This decision recognizes that in some areas of our nation the freestyle division may include both finger shooters and release shooters, and may be predominantly one type or the other. In areas so desiring, a flexibility is provided which allows splitting the division and creating a separation for finger shooters. It is likely such arrangement will be established at the national and sectional tournaments this year.

4. The Amateur Bowhunter Division was re-instated at the National and Sectional level.

5. A motion to restrict all NFAA Amateurs to FITA shooting rules and equipment failed to pass.

6. The Youth Division was changed to include all young archers, 16 years and below. A Cub Division was created for those 11 years and younger. Shooting distances for Cubs are limited to 30 yards.

7. A 15 target field, hunter, and animal round, experimental in Ohio for several years, was adopted as an additional round. It changes our 80 yard walk-up target to a 65 yard walk-up, and adds a 30 yard walk-up. At present there is no provision to use scores of this round for establishing a handicap to be used on regulation 14 target courses and vice-versa.

In conclusion, it is my observation that the actions of your Board of Directors are positive, creative and enthusiastic. Most important of all is the absence of action to outlaw or alienate any segment of archery. This has to be a new high for our beloved sport.

## BOARD OF DIRECTORS

**Paul E. Murphy**  
607 W. Lake Dr., Bessemer, AL 35020

**C. C. McConnell**  
P.O. Box 3717, Kona, AK 99611

**Terry Hardesty**  
105 Rife Dr., Apt. #3, Rogers, AR 72756

**Thomas A. Fisher**  
310 N. Cnsmon Rd., Mesa, AZ 85207

**Pat Norris**  
2007 High Street Alameda, CA 94501

**Cecil Barrett**  
2514 Linda Lane, Colorado Springs, CO 80909

**John E. "Ed" Little**  
35 Virginia Ct., Uncasville, CT 06382

**Edward P. Goffinet, Jr.**  
2403 Annwood Drive, Wilmington, DE 19803

**Dr. Jack L. Barra**  
9801 Baymeadows Rd. #22, Jacksonville, FL 32216

**Janis Beverly**  
1434 E. Lamar St., Americus, GA 31709

**James Archuleta**  
1302-A Ala Moana Blvd., Honolulu, HI 96814

**Jack W. Fisher**  
Rt. #1, S. Meridian Rd., Kuna, ID 83634

**Roland Mantzke**  
1260 Constellation Dr., Aurora, IL 60505

**Robert M. Tinkey**  
305 W. 3rd St., Ligonier, IN 46767

**Ray H. Barnes**  
728 14th Ave., Coratville, IA 52240

**James Morgan**  
2304 College, Topeka, KS 66611

**Giltner Meeks**  
Rt. 2, Box 222, Dry Ridge, KY 41035

**Harold Barnette**  
8814 Cogh Lane, Shreveport, LA 71106

**Carroll Frost**  
RFD 1, Lincolnville, ME 04849

**Paul J. Double**  
Rt. 1, Box 36-B, Freeland, MD 21053

**Robert Tate**  
17 Killredge St., Beverly, MA 01915

**David Colter**  
Rt. 1, Schoolcraft, MI 49087

**John O. Larson**  
755 Mohican Lane, St. Paul, MN 55118

**Alton Dunnaway**  
5127 Mallox St., Jackson, MS 39209

**James Schulz**  
906 Divarsey Dr., St. Louis, MO 63126

**Doug Newbury**  
233-2nd St., NW, Grcal Falls, MT 59404

**Jack Hurst**  
5106 N. 93rd Ave., Omaha, NE 68134

**Marlene Crim**  
929 Spruce Cr., Las Vegas, NV 89106

**LaVern Lavole**  
73 Palm St., Nashua, NH 03060

**Paul Torre**  
138 Reldyes Ave., Leonia, NJ 07605

**Joe Beggs**  
105 E. Gladden, Farmington, NM 87401

**Herold A. Converse**  
183 Ballard Ave., Rochester, NY 14626

**Derrill F. LeCroy**  
1428 Mariborough Rd., Fayetteville, NC 28306

**Robert Gangl**  
St. Anthony, ND 58566

**Robert J. Breneman**  
723 Vine St., Coshocton, OH 43812

**Wilbur Corley**  
212 S. Ferrdue, Claremore, OK 74017

**Fern Epperly**  
1800 Lakewood Ct. #8, Eugene, OR 97402

**John Henneberry**  
South County Tr., West Kingston, RI 02892

**William A. Shain**  
101 Shady Lane, Clemson, SC 29631

**Alvin E. Meisehelmer**  
214-2nd Ave. SW, Watertown, SD 57201

**Jerry Wise**  
301 Chickamauga Rd., Chattanooga, TN 37421

**Joe Butts**  
5775 Sunset Rd., Fort Worth, TX 76114

**Ray Howard**  
942 Statice Ave., Sandy, UT 84070

**Michael Silvchak**  
RFD, East St., E. Clarendon, VT 05759

**William K. Bolt**  
9345 Linton Hall Rd., Bristolow, VA 22013

**Roland Haggard**  
7316-141st Ave., NE, Redmond, WA 98052

**Harmon Eugene Brown**  
Rt. 1, Box 19, Cameron, WV 26033

**David Hackett**  
Rt. 4, McDonald Dr., Lake Geneva, WI 53147

**Tom Prosser**  
Box 80, R.F.D., Lovell, WY 82431

**Jim D. Carper**  
36th AMS-CMR Box 1009, APO NY 09132

**Bill Sadvar**  
44th Ord (BM) (GS) APO SF 96331



**YOUR** National Field Archery Association Officers and Board Directors, as a result of their recent meeting held in Portland, Oregon on February 2nd, 3rd and 4th, made a number of decisions. Following is a summary of the majority of these decisions. The complete official minutes of the meeting are still to be completed and distributed.

1. Voted NOT to accept the proposal from Park Rapids, Minnesota to relocate the NFAA Headquarters in that city.

2. Agreed that nominations for President and Vice President will be accepted by the Board of Directors Council from any Board Member.

3. Approved having the NFAA Board of Directors Council approve all items of equipment prior to their allowance in NFAA competition with the effective date and implementation not to exceed one (1) calendar year from the conclusion of this meeting.

4. Approved the following budget for 1973:

EXPENSE	
Salaries	\$35,500
Adv. and Promotion	5,000
Insurance	3,000
Legal and Auditing	1,000
Mailing and Shipping	6,000
Office Supplies	5,000
Repairs & Maintenance	1,000
Taxes - Payroll	3,000
Taxes - Property	1,700
Telephone	2,000
Travel - Directors	5,000
Travel - Councilmen	2,200
Travel - Officers	1,500
Travel - Sectional Council	1,000
Travel - Bowhunter Council	900
Utilities	1,000
Equipment Purchases	2,000
Interest	200
Game Awards	1,300
Archery Magazine	75,500
IFAA	1,000
<b>TOTAL EXPENSE</b>	<b>\$154,800</b>

INCOME	
Merchandise	\$13,500
20 Pins - Field	2,400
20 Pins - Hunter	1,200
15 Pins - International	500
Annual Tournament	5,500
Sectional Tournaments	3,000
Indoor Program	4,000
Membership Dues	38,000
Course Approvals	2,600
Club Insurance	3,000
State Affiliation Dues	1,000
Rent	1,260
Archery Magazine	
Subscriptions	51,000
Advertising	28,000
<b>TOTAL INCOME</b>	<b>\$154,960</b>

Councilman Bill Boyle's committee works out the budget printed above. This committee sees to it that all necessary services are provided for NFAA members.

## Your Board of Directors

*A summary of decisions made in Portland which*

5. NFAA Bowhunter Membership shall be included for the purposes of membership voting as covered in Article V, Section B of our Constitution.

4. Agreed to allow a maximum number of archers in a group to be six. Reference Article VII, Section G, Paragraph 1, Page 19 of our By-laws.

7. Modified Article VII, Section D, Paragraph 1 (e), page 18 of the By-laws to read: "No mechanical device will be permitted other than one non-adjustable draw check and level mounted on the bow, neither of which may extend above the arrow."

8. Professional Division accepted within the NFAA under the following conditions:

• **CODE OF ETHICS.** The NFAA Pro Division member shall conduct himself in a manner (inclusive of dress) that will bring respect and honor to the National Field Archery Association.

• **MEMBERSHIP.** Archers eighteen years of age and over, and a NFAA member in good standing, shall be eligible for membership.

• **STEERING COMMITTEE.** Proposals concerning this division will be administered by a committee consisting of eight members, one elected from each of the eight NFAA Sections. This member to be elected by the pro division members of that section at the annual Sectional Tournament. The members of the committee shall serve a two-year term with four members to be elected each year. The committee will elect a chairman from within to chair the meetings of said committee. The chairman of the Pro Division would attend the annual Board of Directors meeting with the status of Council Member, with any expenses incurred to be paid from funds in the Pro Division.

• **DUES AND FEES.** The annual dues for this division will be \$50.00, payable January 1 of each year to NFAA Headquarters, which is in addition of the applicable NFAA membership dues paid through the members' state



## Takes Action

*will shape the NFAA's future*

association. Members who fail to pay their pro division dues by January 31 will automatically be dropped from the Pro Division. The following guidelines will be used in disbursing membership dues:

National Championship Prize Fund	\$15.00
Sectional Championship Prize Fund	10.00
Tournament Guarantee Fund	10.00
NFAA administration cost	5.00
Emergency Fund	
Chairman Expense Fund Patch	10.00
	<b>\$50.00</b>

• **TOURNAMENT SANCTION.** Tournament sponsors wishing sanction of their tournament by this division shall furnish the chairman of the Pro Division a letter of guarantee verifying an obligation to make payment of the advertised purse. Sanction fee would be \$15.00; \$10.00 of which will be added to the Pro Division tournament guarantee fund and \$5.00 to the NFAA treasury. This division may furnish a consultant for advisory assistance for said sanction fee if requested. Any sanctioned tournament means the purse is guaranteed.

• **EQUIPMENT RULES.** Participants in tournaments sanctioned by this division will abide by the equipment rules of the National Field Archery Association.

• **TOURNAMENT COMPETITION.** Members of this division will not compete for awards other than money and/or merchandise in tournaments below the state level. At the NFAA National and Sectional Tournaments the Pro Division Member will be required to compete in the Pro Division. At the State Championship he will be required to compete in the Pro Division, if one is available. However, members are encouraged to support all types of tournaments

by purchasing a score card for the regular registration fee.

9. The following Bowhunting Committee recommendations were approved and accepted:

• NFAA select a Bowhunter Team to represent the NFAA at the Douglas, Wyoming National Bowhunt. This team made up of three NFAA members in good standing. Persons shall be nominated by a Director or Councilman and shall be selected by the NFAA Bowhunting and Conservation Committee by lottery at the annual meeting. As an urgency measure, the 1973 team shall be made up of Directors and/or Councilmen. The following selections were made for 1973: John Durham, John Larson and Bill Bolt. The three alternates selected were: Paul Murphy, first alternate; Terry Hardesty, second alternate; and Max Tinkey, third alternate.

• **BOWHUNTER BONANZA** - NFAA to sponsor a Bowhunter membership campaign with the prize to be a one week hunting trip, such trip to be under the supervision of a regular licensed guide, etc. It is open to NFAA members and to be included in the drawing, your name and address should be placed on the back of each new Bowhunter Membership application that you may have sponsored. Drawings will be made each year at the annual meeting. For 1973 the drawing will be made on July 1, 1973.

• **BOWHUNTING FOR DEER BOOK** to be made available (details forthcoming in the next issue of Archery)

• **NATIONAL BOWHUNTING RENDEZVOUS** to be back in Georgia again.

• **ART YOUNG AWARDS** revised according to Article XVI of NFAA By-laws, which follows. An \* in the left hand margin indicates where a change occurred.

### ARTICLE XVI ART YOUNG AWARDS A. GAME AWARDS OF THE NATIONAL FIELD ARCHERY ASSOCIATION

1. There shall be two. The "Art Young Big Game Awards" and "Art Young Small Game Awards."

2. **PURPOSE:** The purpose of the Art Young awards is to promote interest in hunting with the bow and arrow, to encourage good sportsmanship and to give recognition by the organized field archers to their members who obtain game with the bow.

3. **RULES:**  
(a) All animals must be taken in accordance with the laws of the State, Territory, Providence, or County, whichever is appropriate, and in accordance with the rules of fair chase.



Councilman George Chraft reports the recommendations of his Pro Division committee, which are reprinted on these pages.

\* (b) In order to be eligible for awards, all animals must be reported within 90 days of the date taken. A handling fee of 50 cents must accompany each application.

(c) The hunter must have taken possession of the animal to receive credit for the award.

(d) It shall be the responsibility of the hunter himself to know the legal status of the species hunted. National Headquarters is responsible only to the extent of verifying whether a species is, or is not protected, since this is the basis of acceptance.

(e) Animals specified as big game by the NFAA are not eligible for credit in the Art Young



## DIRECTORS' ACTIONS Continued

Small Game Awards system.

- (f) Members who willfully take game out of season, take protected animals or otherwise violate game laws, falsify a claim or deliberately witness a falsified claim shall be expelled from the NFAA and all its programs. An expelled member may petition the NFAA for reinstatement after one year. The Bowhunting and Conservation Committee shall rule on the petition.
- \* (g) An additional award shall not be given for game previously accepted under a prior awards system. (People who had amassed a combination of seven or more pins under the old program as of July 1, 1973, and have so requested by January 1, 1974, shall be allowed to continue the old program. The same animals used in claiming any portion of the old Master Bowhunter Award may not be used again for awards in another program.
- (h) Any game taken from areas where they are officially designated as "rare" or "endangered shall be ineligible for awards.
- ### B. ART YOUNG BIG GAME AWARDS
- #### 1. DEFINITION OF BIG GAME:
- (a) All species of American bears. For lack of confusion the "Alaskan Brown Bear" will be considered a grizzly (now so recognized by most modern taxonomists).
- (b) Big cats including mountain lions or cougars.
- (c) The deer family including elk, moose, caribou, and various species of native deer.
- (d) All other native hoofed animals including proghorns, sheep, goats, and javelina.
- (e) All feral (gone wild) swine (boars), sheep and goats if recognized as "game" by the local conservation department.
- (f) Any animal considered big game by the local county or province.
- #### 2. ELIGIBILITY.
- Eligibility for "Art Young Big Game Awards" is limited to members of the NFAA



Directors Jerry Wise and Paul Murphy listen to various sides expressed on an issue before the Board.

### GAME:

- (a) Any animal recognized as small game by the local conservation department in the area taken.
- (b) Any small mammal, bird, fish, or poisonous reptile generally recognized as a nuisance or harmful, but not necessarily defined as game by law.

\*2. **ELIGIBILITY:** This shall be the same as for the "Art Young Big Game Award". If several species are taken within such a 90 day period, they may be held and reported at one time. However, no species may be reported more than 90 days after taking.

### \*3. AWARDS:

- (a) The Art Young Small Game Arrowhead Pin shall be given upon taking the first six species of small game.
- (b) For each additional four species taken by a member, an additional award in the form of a bar with the number 4 shall be presented to the hunter. There shall be no limit to the number of bars which may be earned, but all game must be legally taken.
- (c) A separate patch shall be made available for each species taken.
- (d) A particular species may not be claimed more than once by any bowhunter participating in Art Young Small Game Program, except in states which have fewer than 3 species designated legal small game for bowhunting. At least one of the animals claimed must be considered "game" by the local conservation department.

\*4. **AWARDS:**

(a) Art Young Big Game Pins shall be given for only the first example of each species taken according to the NFAA rules.

(b) Cloth patches for additional examples of each species taken with the bow and arrow according to the NFAA rules will be awarded.

(c) The Art Young Big Game Award shall be given when one adult big game animal is taken according to NFAA rules. Awards for additional big game animals shall be in the form of certificates. Additional animals claimed under this program may be of the same or may be of different species.

### \*D. BOWHUNTER AWARDS:

1. There shall be three classes of Bowhunter Awards.
- (a) Bowhunter pin
- (b) Expert Bowhunter Pin
- (c) Master Bowhunter Medal
- #### 2. ELIGIBILITY:
- (a) A person may be awarded

Next month, watch these pages for President Kreisler's keynote address, plus more highlights of the Board of Directors' meeting...

the Bowhunter Pin when he has earned the Art Young Small Game Arrowhead Pin and one four bar and two Big Game arrowhead Pins.

(b) A person may be awarded the Expert Bowhunter Pin when he has earned the Bowhunter Pin plus one additional four bar and one additional Big Game Arrowhead Pin.

(c) A person may be awarded the Master Bowhunter Medal when he has earned the Expert Bowhunter Pin plus three additional four bars and three additional Big Game Arrowhead Pins.

### \*3. CLAIM OF AWARDS:

(a) All applications must be made to the NFAA Headquarters. Verification that all species, to the best of his knowledge, were legally taken must be made by another NFAA member. No applica-

tion will be accepted by NFAA without such verification.

### E. DIAMOND BUCK AWARD:

1. The Diamond Buck Award will be given for the largest example of mule deer, white-tail deer, and black-tail deer based on antler measurements. The antlers must be scored by Pope and Young Club or Boone and Crockett methods and verified by one of these club's official measurers. Applications shall be available from NFAA Headquarters and from Section Officers of the NFAA in charge of bowhunting.

### F. APPLICATION DISAPPROVAL

1. In the event an application is disapproved, the hunter has the right to petition the NFAA Bowhunting and Conservation Committee. The petition must be in writing and must state the facts of the claim. It shall be the responsibility of the review com-

mittee to study the applicable game laws and the petition and made a recommendation to the Bowhunting and Conservation Committee. The Chairman shall appoint the three-man committee to rule on the claim to act on the claim within 60 days.

2. The results of the petition shall be kept confidential, but the ruling shall be sent in writing to each member of the committee, the NFAA Headquarters and the petitioner.

10. The Amateur Bowhunter Division was re-instated at the Sectional and National level.

11. The 15 target field, hunter and animal round was adopted as an additional round.

12. A change in the youth division was made to include all young archers, 16 years and below. A Cub Division was included for those 11 years and younger.

13. St. Louis was selected as the sight for the 1974 annual meeting.

## How to join NFAA's new pro division

If you are considering turning professional and your philosophy lies within the scope of the NFAA, you may join the NFAA Professional Division by completing this application and forwarding it along with \$50.00 to NFAA Headquarters, Route 2, Box 514, Redlands, California 92373 (see page 28 of this issue for details of NFAA legislative action on the pro division).

### NFAA PROFESSIONAL DIVISION APPLICATION

Name \_\_\_\_\_

Address \_\_\_\_\_

City \_\_\_\_\_ State \_\_\_\_\_ Zip \_\_\_\_\_

Date of Birth \_\_\_\_\_ Social Security No. \_\_\_\_\_

Current NFAA Membership State Assoc. \_\_\_\_\_

Male \_\_\_\_\_ Female \_\_\_\_\_





## NorScope 560

PRECISION SIGHT

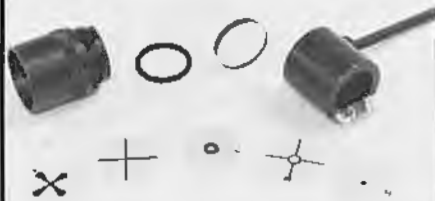

\* SPECIALLY ground glass OPHTHALMIC LENS insures better aiming and crystal clear sighting image. (Any type or style of peep sight should be used.)

\* MACHINED of highest QUALITY aluminum, the NorScope 560 sight screws apart to clean lens or change sight reticle. Anodized for NO GLARE with a tapered front lens cover — like a fine rifle scope.

\* 8/32 Windage screw is parallel to MACHINED SLOT for BUBBLE LEVEL, and fits almost all sights. Our unique design completely eliminates the sight body from rotating on the windage screw. Result: GREATER ACCURACY.

\* CLEARER — LARGER IMAGE of target increases your CONFIDENCE and ACCURACY. Scopes are now being used by almost all top contending champions.

\* Ten separate aiming reticles available in both clear and amber give you plenty of selection other than the common dot.

\* A BONNIE BOWMAN PRODUCT insures you of uniform quality in all sights.  
DEALER INQUIRES WELCOMED

only **\$17.50**  
with three aiming reticles

spare reticles  
3 for \$1.00 or 45c each  
Order Right or Left Hand  
**BONNIE BOWMAN**  
**ARCHERY**  
2007 High Street, Dept. A3  
Alameda, CA 94501  
Telephone: 415-521-4411

## SECTIONAL REPORT

### GREAT LAKES by ROLAND MANTZKE

#### Illinois

An unofficial count showed that 2,746 Illinois whitetail were taken during the second half of the shotgun deer season. This brings the unofficial hunting bag total taken to 10,284 deer in 1972, 97 fewer than during 1971's record harvest.

The largest buck taken during the second gun season was 246 lb. field dressed; the largest doe came from Adams county, and we might make note of this for next year. The largest amount of deer were harvested in Ogle County; second Joe Daviess; third Cass. Chuck Maloney scored again with a Pope and Yount mountain lion taken in Utah.

Congratulations to Gary Kupczyk for shooting a perfect 864 Chicago Round on December 14 at Golden Arrow club lanes. I think Gary should be complimented on this feat. Although we can't class it as an official state record, it definitely is a score that will be hard to beat. I might add Gary was shooting a finger tab. Good shooting for a 20-year-old.

#### Indiana

Eagle Creek Archery Range will host the Great Lakes Sectional. The four star range is located in Eagle Creek Park, the nation's largest and one of the most comprehensive municipal park and na-

## SECTIONAL REPORTERS

NEW ENGLAND (Europe, CT, ME, MA, NH, RI, VT.), Phyllis B. Butters, 23 Walnut St., Danvers, MA 01923; MID ATLANTIC (DE, MD, NJ, NY, VA, WV), Jerry Ebert, 519 Sandy Place, Oxon Hill, MD 20021; SOUTH-EASTERN (AL, FL, GA, KY, MS, NC, SC, TN), Adelaide L. Wise, 301 Chickamauga Rd., Chattanooga, TN 37421; SOUTHERN (AR, LA, OK, TX), Ann Sparks, 1506 Marion, No. Little Rock, AR 72114; MID WESTERN (IA, KS, MN, MO, NE, ND, SD), Doris McGowan, 1290 34th St., N.E., Cedar Rapids, IA 52402; GREAT LAKES (IL, IN, MI, OH, WI), Roland Mantzke, 1260 Constellation, Aurora, IL 60504; NORTHWESTERN (AK, ID, MT, OR, WA, NY), Janice Berry, Route 2, Box 207, Forest Grove, OR 97116; SOUTHWESTERN (AZ, CA, CO, HI, NV, NM, UT, Okinawa), Marlene Crim, 929 Spruce Circle, Las Vegas, NV 89106;

ture preserves. The park belongs to and is maintained by the City of Indianapolis Department of Parks and Recreation.

The range is located in the southwest corner of the park, where there are two courses of 28 double-butted targets located mostly in woods with a few in the open. The area is hilly and rough in spots, but thanks to bridges and steps in these areas, the going is easy. The range is a challenging one and should be enjoyed by all.

A large barn, on the grounds, serves as the club house, shelter and also houses the food concession. Camping at the range is adequate and is strictly primitive with portable toilets and water at the barn or a water tanker if available.

### MID-WEST by DORIS MCGOWAN

Some complaints have reached me on the news of this area. My main sources of news are state publications and individual clubs who report. It was said not so much club news is needed, but news of higher level. What is this area made up of—clubs? I thought so. When they take the time to send news, I feel it should be used.

If a higher level is desired by you, the reader, kindly send some material so we can use it. Perhaps each state could co-ordinate what they will want to read about. I will send in what you want. May I hear your comments?

#### Iowa

The Waltonians annual Silver Broadhead will be held May 20 at Enders Field north of Cedar Rapids. This is their big event of the year. A bowhunters shoot has been added the past two years and will be going strong again.

Genuinely sterling silver broadheads are mounted on jewelry etc. and given to each class winner. There is lots of good food, lots of

camping area and a good well. Folks from far and near are invited to come and shoot — only \$3.00 for adults and \$7.00 maximum family. We appreciate those who come faithfully year after year and the new ones who have joined in more recently. Without you, there would be no shoot.

Des Moines archer, Linda Marten, was the women's professional winner at the Phoenix Open. Her scores were 29% and 292. Capital City hunters scored well with 40 per cent success. Sixty Des Moines Archers accounted for 21 deer and three elk. About 50 youth are taking part in the JOAD program on Friday nights, sponsored by the Waltonian Archers.

#### Kansas

Muriel Elchuk becomes the new state secretary. Her address is 1606 Marland, Hutchinson, Kansas 67501. Muriel is an accomplished archer and will make a very welcome addition to the executive board.

The Emporia club starts the year with Bob Mundy as president. Thomas Cormack has been working with the Jr. Olympic Archery program which serves five to six hundred youths in the state. This year they experienced their first field tournaments. More volunteers are needed. This is an excellent promotional program for Kansas archers.

Chuck Grey assumes the presi-



Eleanor Mocsadlo, of Cleveland, — of the sport. With her is Howard Myers, who is also wearing his Medal of Merit pin.

dency of the Salina Bowmen. Their club held the State Indoor, February 25; results as soon as received.

The Central Division will shoot a field and animal on May 6, while on June 10, the Western Division will have an International and hunter. Division shooting is a good way for area archers to gather and strengthen the state program.

#### Missouri

According to Paul Jeffries' hunting report, Frank Tolivar has a string of deer kills to be proud of, having just taken his 16th deer in 15 years.

Missouri Bowhunters are rallying to the problem of what is being said against hunting. Let readers in all parts of the country join to protect our sport and preserve what has always been a natural way of life.

The winning team of the last league from Ashland consisted of Rusty Phillips, Jim Lewis, Bill Cunningham, Rex Taggart and Robert Hagans. Dean Pridgen shot the high of 448 at Joplin's Indoor. Dennis McCommack had 439 by the old finger method.

It was interesting to read that the Bowmen of Springfield were reorganized after World War II

## THE FINEST FLETCHING EQUIPMENT FOR PERFECT ARROW MAKING

No other fletching equipment gives you all these features: 1. Dial your setting and you can fletch your arrows diagonally, straight, or true helical fletch right hand or true helical fletch left hand. 2. Spaces feathers or vanes 120°, 90°, 75°x105°, or 60°. 3. Precision die cast, form fitted thumb controlled clamps. 4. Knife edge on base of clamps eliminates build up of surplus glue. 5. Graduated scale on side of

clamp for spacing feathers or vanes accurately from nock. 6. Allows clear view of fletching work at all times. 7. New self-centering nock receiver fits all nocks. See the most advanced, versatile and accurate fletching jig in archery at your dealers or order direct. Jig with straight clamp \$25.00. Right or left hand true helical clamp \$27.50. (Specify)

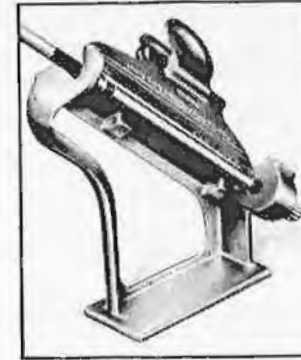
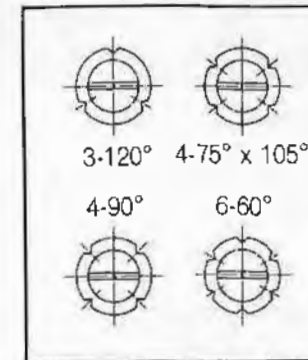
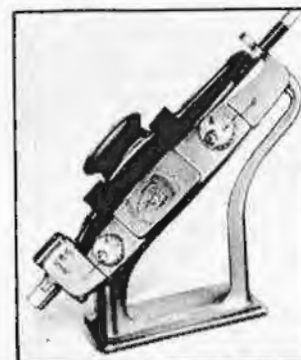

## THE BITZENBURGER DIAL-O-FLETCH

HENRY A. BITZENBURGER, ROUTE 2, BOX M-1, SHERWOOD, OREGON 97140





"Jim Bibb (Calif.) took this beautiful four point buck the last afternoon of his 1972 deer hunt in Colorado's scenic high country. Many other bucks were taken during this same season. Some larger, some smaller. For information on the upcoming 1973 season write or phone:

## Jerry Byrum GUIDE and OUTFITTER

POST OFFICE BOX 1503-A  
GRAND JUNCTION, COLORADO 81501  
TELEPHONE (303) 242-2479



### MAKE EVERY SHOT COUNT

Stable arrow right out of the bow. Shoot silently through the narrowest opening. Means better penetration. BERGER BUTTON. Now in mini length too.

Vic Berger, 1019 Garfield Ave., Springfield, Ohio 45504

## FREE DISCOUNT ARCHERY CATALOG

From The Nation's Leading Archery Distributor

- Guaranteed Service — All Orders Shipped the Same Day Received
- Guaranteed Selection: All the 1973 Top Lines
- Get Lowest Prices Possible

PHONE  
WIRE  
WRITE

FOR FREE ILLUSTRATED CATALOG

### ANDERSON ARCHERY CORPORATION

Box 130 Dept. A

Grand Ledge, Michigan 48837

517-627-4021

SATISFACTION GUARANTEED

IN BUSINESS OVER 20 YEARS

and were known as the Ozark Target Association. It was then that Norman, Jack and Bob Wilson joined the club and did so much through the years. A tribute to Norman Wilson and sympathy to his family was printed in the state Release. The Wilson Bros. manufacture one of the country's leading bows — the Black Widow.

Don't forget the state convention, March 25.

### MID-ATLANTIC by JERRY EBERT

With this issue the spring shooting season is upon us, and the results of last year's bowhunting accomplishments are in. Before going into the activities that lie ahead, let's review the bowhunting record of one club, Lincoln Park Archers of Towaco, N.J., whose members took one barren ground caribou, two black bear and 17 whitetail deer — more on this in the New Jersey column. During the 1972 New Jersey bow and arrow season, 1,459 deer were reported taken, with 371 harvested in Hunterdon County alone.

Will the secretaries of each state association please send me your 1973 shooting schedules. Here are a few shoots coming up: The West Virginia Indoor Championships will be held at New Haven on March 17 and 18, while that state's Open will be on May 27 and 28 at Rainelle. On May 27 also is the big Maryland Carling-Kernan Charity Shoot at the Carling Brewery in Baltimore. The Eutaw Forest Archers of Accokeek have scheduled their big Gold Cup Shoot for June 2 and 3. At their free bull roast last year, 250 lb.

of prime beef was consumed by the happy crowd.

### Maryland

Here are the results of the state elections: MAA president, Whitey Metheny; vice president, Pete Thompson; secretary, Margaret Mazzeo. Target division officers include Mark McCloy, director; H. A. Brown Dunning, deputy director; Gil Frey, national representative.

Indoor division officers are Jean McGeeney, director, and Jerry Ebert, national representative. Heading the field division are Larry Rice, director; Charles Baker, deputy director; and Paul Double, national representative.

The MAA meetings are now held with the semi-annual in May and the annual in November. The 1973 Broadhead Championship was awarded to Eutaw Forest Archers for September 9, and the Target Championship was awarded to Oriole Archers for September 23. The Target Division has established a non-conformist category for amateur and non-amateur shooters. The MAA council has changed the Indoor Division shooting rules to NFAA rules.

Allen Becker has been elected president of Mayberry Archers. Three cheers to out-going president Mike Weaver. Mayberry should have 14 targets lighted by now so look for some night shoots. Neal Blizzard will ramrod the Cumberland Bowhunters for '73. Don't forget Pikesville will host the Mid-Atlantic this year.

### New Jersey

Isadore Donatello and Walter Krom of Lincoln Park Archers scored on black bear in Maine. Walt's bear will make the Pope and Young records. Mr. M. Barone will make the records with a barren ground caribou taken in the Nagava Region of Quebec. John Lupi, N.J. State Bowhunting Champion, scored on deer in N.Y., N.J. and Pa., a first in the Lincoln Park Archers Club. Robert Drumm scored on largest deer in club in club. In the small game category, the awards go to Mr. H.

Shafner for carp and Mr. Walter Krom for woodchuck.

### West Virginia

The association held its annual meeting in Charleston and awards were presented to the current state champions. Recognition was given to clubs for their work in 1972 and Claude Davis was named bowhunter of the year for 1972. Host for Open Championship is Greenbrier Field Archers, Rainelle, on May 27-28; contact Mrs. Nott, Sandy Hgts. Addition, Pt. Pleasant, W.Va. 25550. Host for Target Championship is Princeton Archers Club, of Pipestem, on June 16-17; contact Dan Farley, 501 Hale Ave., Princeton, W.Va. 24740 or WVAA secretary, Nancy Nott.

Just received the sad news on the death of one of Archery's staunchest supporters for 17 years, Mr. Bob Kolb of Kolb's Arrow Shop. Bob never forgot a tournament or state shoot and will be missed by us all.

### SOUTHWEST by MARLENE CRIM

### California

Black Mountain Bowmen held their "Morning After the Night Before" shoot on January 7, with the following winners: Bill Dahl took first place in men's FS, AA class, followed by Rich McClintock and Carl Kelley, while Peggy Auser won the women's FS/A competition. Barebow winners were Jim Davis and Jeanne Molyneaux, and Marge Kelley took top

## P. O. CEDAR ARROW SHAFTS

Another Exclusive . . .

### DIAMOND Polished Arrow Shafts

P. O. CEDAR · SLOW CURED BILLETS  
DEPENDABLE QUALITY · DEPENDABLE SERVICE  
15 YEARS OF KNOW-HOW

Norway Archery

NORWAY, OREGON 97460

PRICE LIST FREE ON REQUEST TELEPHONE (503) 572-2950

## SWEETLAND ARCHERY PRODUCTS FROM TIP TO TRACER

### FORGEWOODS —

Bring down the big ones with the slender one!  
The Compressed Cedar shaft with amazing penetration!  
THREE GRADES TO CHOOSE FROM:

	Bare Shafts	Finished Arrows Less Points
SUPREME BATTLESHAFT	\$13.95	\$21.95
HUNTER over 29"	9.95	17.95
HUNTER 29" long	7.50	12.95
	6.50	12.95



### FUR TRACERS —

Simply cut off a small piece of our Fur Fletch on an angle so the ends overlap, strip off the paper backing and wrap the self adhesive on your hunting arrow, close to the fletch. They're wonderful in all kinds of shooting! Lower arrow shows how fur is used in target shooting.

\$2.50 for 1 Doz. 4-1/2" strips, \$18.00 per 100.  
Specify White, Red, Yellow, Blue or Orange.

SWEETLAND ARCHERY PRODUCTS  
1010 Arrowsmith Street, Eugene, Oregon 97402 (503) 345-0928



## BOW HUNTERS

We can't promise all our guests they will bag record-class muleys like these. We can promise you a real good hunt and a grand time during your stay on our 20,000 acres of prime deer country. In past seasons our hunter success has been excellent. The two beauties shown here were taken during our recent hunts. Plan now to join us in the high country of Western Colorado.

Write for information.

JOHN LAMICQ, JR.

478 29th Road, Apartment 2  
Grand Junction, Colorado 81501

NOTE: WE ARE NOW BOOKING ELK, LION, ANTELOPE AND BEAR HUNTS.







*Indiana archers mourn the passing of Don Seal, Mr. Archery in their state, who worked for over 25 years to promote the sport. He was the first representative to the NFAA, and also served as state field governor, state field president and Hoosier State Target Assn. president. The only Hoosier ever to receive the NFAA Medal of Merit, he was also a bowhunter and woodsman par excellence, taking Newfoundland moose and caribou, wild board, and over 20 deer in the Great Lakes states. His friend Guy Gustin recalls his unselfish attitude and his philosophy, which remains a tribute to the man: "May I always enjoy the chase more than the kill, the shooting more than the winning, and above either, the friendship of my fellow man."*

honors in the women's BH A class. Vern Roberts won the money shoot.

The Black Mountain Bowmen also want to offer congratulations to their member, Don Kouns, one of the few to shoot a perfect 300 on the first day of the U.S. Open at Las Vegas. Don also won \$25 for being the best-dressed left-handed shooter.

The California State Broadhead Championship will be held on the

San Jose Archers range over Memorial Day weekend.

#### Nevada

Archers in Las Vegas recently completed their Wednesday night indoor league. Teams winning top money were Van and Janae Marshall, first place; Larry and Marlene Crim, second; and a tie for third place between Mary Lynn Snyder and Lou Shine with War-

ren and Louie Snyder. High game and high series winners were Mary Lynn Snyder and Bob Hutto.

Congratulations to all our local archers who won money at the recent U.S. Open — especially to Mary Lynn and Louie Snyder who placed 2nd and 4th in the women's division.

#### Utah

The Timpanogos Archers announce the following newly-elected officers: Alvin Harward - president; Davain Johnson - vice president and Larry Hartley - secretary. Erma Nelson will be their reporter.

The Timp Archers got their 1973 season off to a good start with a successful indoor shoot held recently at the Armory at American Fork. Among the winners were Bob Jacobson, of Springvielle, who shot a perfect 300 to highlight the shoot. Placing second was Duane Johnson. First place for the ladies was Joyce Johnson in the AA class with Erma Nelson second. Men's BB and BH were won by Grant Draper and Eugene Halverson. Youth winners were Michelle Johnson and Rick Sorenson.

#### NEW ENGLAND by PHYLLIS BUTTERS

#### Connecticut

Many young archers in Connecticut are currently participating in the Pequot Junior Olympic Archery Program, sponsored by and conducted at Ed and Nan's Archery Lanes in Taftville. The program began about two years ago and approximately 75 youths are presently taking part. The Junior Olympic archers meet at the lanes each Saturday morning to shoot the required rounds for their respective achievement levels. The archers move up a step on the achievement ladder by shooting the required score for a given distance at a given target face. Robert Brown achieved the highest level of Olympian before he reached his eighteenth birthday last spring. These are the young archers who represent the future

best of luck in the continuation of

the program.

The Norwich Archery Club conducts an indoor league program at Ed and Nan's Archery Lanes on Tuesday nights. The members shoot the NFAA Indoor Round, and the following are the individual averages as of December 1, for those archers with a minimum of three scores: Ed Brown, 292; Chick Pierce, 289; Dan Watson, 288; Dave Goddard, 282; Mac Snelgrove, 278; Ed Little, 275; Frank Janus, 246; and Jean Goddard, 227.

On January 7, Art Hall of Hall's Arrow Indoor Archery Lanes in Manchester held a warmup shoot for the annual New England Open money tournament. Fifty dollars cash was guaranteed to the first place finisher in the warmup event, and Norm O'Kane of Manchester, the 1972 New England Open winner, won it with the highest score shot thus far this season in Connecticut—a 299. Norm's fantastic 299 score was a real heart-breaker, as he dropped that one arrow on the next-to-last arrow of the final end.

Also on January 7, Dick LaMar of LaMar's Archery Lanes in Bristol held his regularly scheduled monthly money shoot, with a total of 22 pros and 4 amateur shooters in attendance. More than half of the archers competing were from out of state, some coming from as far away as New York and New Jersey, but the Connecticut delegation managed to keep most of the money in their home state.

At Jim St. Pierre's Spitfire Lanes in East Granby on January 28, the Connecticut Barebow shooters made a serious threat on the egos of the Connecticut Freestylers as the halfway mark of the money shoot held there saw several barebow archers holding down the top spots in the competition. The second half and the conclusion of the round saw things turn around somewhat. The freestyle contingent managed to salvage the top two places through the efforts of Norm O'Kane and Ed Brown, who shot 295 and 294, respectively.

Barebow archer Joe Pewcio nailed down third place with his fine 293 score, and a score like that should give everyone something to think about for a while. Another fine effort came from Barebow

archer Jim English, who was only two points off perfect at the half but dropped a few more arrows on his way to the finish and didn't end up in the money.

#### Maine

Maine reporter Richard Dunham sends word that indoor programs are becoming active throughout the state. The big event on tap is the Indoor State Championship, to be held in Brewer on April 15. Awards will be given in each competitive division and thereafter all archers collectively will be placed in classes or flights according to the averages of their previous scores.

There will be 10 such classes, ranging from 0-150 to 285-300. This system was used in last year's event with much success and so will be repeated this year. The official round will be the PAA Indoor Round. The tournament also offers a Guest Division, and out-of-state archers and non-MSAA members are encouraged to join in the good times and good competition. Inquiries regarding the tournament may be sent to: Lois Dunham, P.O. Box 448, Belfast, Maine 04915.

Two of Maine's best, Ken and Jan Ulmer, are presently living in Georgia, but they'll be back to their home territory soon. Their plans call for them to travel to California in the spring, then back to Maine to hang their hats on a long-term basis. Ken and Jan ran an archery lanes and pro shop in Old Town, Maine, last season, and Jan made a fine showing for her state and New England when she placed second in the women's open division at the 1972 National Championship in Ludlow.

#### Massachusetts

Tragedy struck the Massachusetts archers on December 17 when the clubhouse of the Old Colony Sportsmen's Club, home of one of our most active member clubs, the Old Colony Archers, burned to the ground in a fire of undetermined origin. All that was left standing was the fieldstone fireplace as the fire raged through the building and the indoor range underneath it. Plans to rebuild the 25-year-old club are already

underway, but it may be some time before a final decision is reached.

The MFAA membership also would like to extend their sympathy and their encouragement for a speedy recovery to Chuck Schultz of Norwell, who is hospitalized in Salem, Mass. as the result of a heart attack. Chuck, who is one of the state's foremost Barebow archers, and his wife Nancy, a former National Barebow Champion, are both members of the Old Colony Sportsmen's Club. Our best wishes to you, Chuck, and we hope you're back on your feet soon.

Billy Hurd of the Danvers Fish and Game Club recorded a perfect 300 score on the NFAA Indoor Round in a shoot held at that club on January 28. Billy was shooting for the Danvers team in an indoor league match against a team of archers from Hudson, Mass. The indoor league was organized by Bill Gagnon of Northboro Fish and Game and Paul Hunt, a member of the Broken Arrow Archery Club, and the member teams began shooting the official matches shortly after January 1st. With several more weeks to go in the 12-week league, everyone should really have something to shoot for after that perfect score by Billy Hurd.



#### COLORADO

Three years of hunting the famous Bookcliff Mtns. have produced 56% kill on bucks Pope & Young heads taken. I furnish everything except license and sleeping bag. 7 days of hunting \$200.

For reference and full information write or call  
**Hollis Atwood, 419-30 Road**  
Grand Junction, Colo. 81501  
Phone 303-243-0279

# THE FAST ONE!



Fast. The Jennings Compound is the fastest shooting bow you'll ever hold. Accurate, more accurate than any bow in manufacture today, at any distance! Arrow flight trajectory so flat it's almost unbelievable. High-strength components and custom assembly make the Jennings Compound the Archer's ultimate bow. Send for your free brochure today. We'll show you how an arrow should fly.

Jennings **COMPOUND** bow

S & J ARCHERY SALES • 10945 BURBANK BLVD. • NORTH HOLLYWOOD • CALIFORNIA 91601



# Tales Of The Feathered Shaft

By Roy Hoff



## "THERE IS HONOR... EVEN AMONG THIEVES"

That was a statement I vividly recalled as I greeted Ted Marak during the recent Las Vegas Open. It was reminiscent of one of the most memorable hunting trips of my life.

There was a time when Ted and Dottie Marak were the Mister and Missus Archery in the Bowhunting fraternity of Las Vegas, Nevada. They were here, there and everywhere when promotion of our sport was needed. Ted was instrumental in the opening of Mt. Charleston Park, thirty-five miles northwest of Las Vegas, for bow and arrow hunting only. It was here we met and our friendship endured for many years, until that fatal day when Ted decided to become a drop-out and go into the "sport of kings," breeding and raising thoroughbred horses.

Now, after a lapse of more than ten years, I came face to face with what appeared to be a fine looking gentleman more than casually interested in the event in progress. Under an arm I could see a copy of Archery Digest, the book which explains all the how-to-dos in archery. He also had a fistful of literature and catalogs advertising the latest in archery tackle.

Ted was again hooked on archery and spoke enthusiastically of turning back the pages and taking up where he left off. It was a real joy to re-live our many previous exciting adventures deer hunting on Mt. Charleston. I'd like to tell you about one.

A group of hunters had gathered at Mt. Charleston Lodge to make final plans to reduce the deer herd. Ted was particularly concerned, considering tomorrow was the last day of deer season. His occupation was a dealer at the Golden Nugget Casino. Ted, exuding confidence, had boasted to a number of

fellow dealers about how he was going into the mountains and bag a buck with his bow and arrow. He was immediately challenged with "Betcha a double saw-buck you don't make out," came from one dealer. Another's reaction was, "I wouldn't mind having a bet like that myself." In a few minutes Ted called all bets which, if I recall correctly, totalled a hundred bucks.

Feeling sort of philanthropic, I took Ted to one side and suggested that he had about as much chance winning those bets as I would hitting a jackpot on a slot-machine. To sort of even the odds, I suggested that I'd join him on the morning hunt and see if I couldn't be helpful in winning his bet. Ted thought a minute and answered: "No dice, roy! You might not believe it, but there's honor — even among thieves! I'll get that buck all by myself or eat crow and pay my bets."

Next morning, before daylight, I parked my car near a cattle-guard where several times during the season I had seen a small herd of bucks crossing the canyon. Each time I was in the wrong place to get a shot or make a successful stalk. Today I would cash in on the knowledge I had gained. If everything went as planned, I would be able to spot the herd from my vantage point, observe the path they were taking, then sneak through the brush and ambush the biggest one.

An hour after I had taken my stand it was broad daylight. I had not seen a deer. I was becoming impatient and the idea of stalking up the bottom of the canyon was becoming more impressive by the moment.

Any such thoughts were immediately dissipated as I saw a car coming up the road. It was an MG sports car which, from the sound, had to be Ted's. I left my stand to inquire if he had seen anything. The look on his face indicated he most certainly had

seen something. He greeted me with: "I just killed a big three-plus-three point buck down in the bottom of the canyon. Now what do I do? I never have dressed a deer and I don't know which end to start on. How 'bout giving me a hand?"

To say I was delighted would be putting it mildly. We drove as far as we could through sagebrush, then hiked the rest of the way to the deer. It was a beauty, but being an ornery cuss, I chewed out our hero for not being more considerate. He had bagged his buck where the canyon walls were the steepest. It was, of course, a real pleasure to show off my ability in dressing a deer and mounting him on a sapling pole. Half way up those steep canyon walls, neither of us thought we'd make it to the top. But we did.

In a short time we were back at the Lodge with Ted's prize beauty. We found Tom Jennings (of recent compound bow fame) photographing a nice forked horn he had brought down during the morning hunt. Pete Larraby also greeted us with a broad smile. He had a nice buck hanging on our meatpole. It was the largest deer taken during the season. The beautiful set of antlers had four points on one side and three on the other.

After having lunch with this select — and lucky — group of bowhunters, several of us decided to try our luck in the Cold Creek area on the opposite side of the mountain. Two carloads of bowhunters made the fifty-mile drive. Upon arrival, the lead car suddenly stopped at the edge of a forest of junipers, and we knew the boys must have spotted some deer. Clyde Crowell and Bill Childs were hurriedly stringing their bows and motioning us to stop and take it easy. We joined them in a few minutes and found they had jumped a herd of about a hundred deer. "The woods are alive with deer," was the way one of the boys put it.

We hurriedly figured out a plan of attack and donned our gear. The boys who were there first fanned out and left in hot pursuit. We got back into our car, with me at the wheel. We drove up a Forest Service road paralleling the area. Every couple of hundred yards I dropped off an archer. First Harold Macquarrie, then my brother, Dr. Hoff, Dick Scott and Hugh Rich. It seemed like we had the area surrounded and there could be no escape. Well, I have news for you. None of us got a shot nor did we see hide nor hair of those deer. When I later saw Bill he gave as good an explanation as any when he said, "Musta crawled down their holes."

As darkness closed in we returned to the car, counted noses and prepared for the long drive to the Lodge. We soon were to have a rather unpleasant, and certainly unnecessary experience. We had to pass within a few yards of the local ranger station on our way to the main road and, as we approached, a bewhiskered and disheveled man ran out into the yard and started waving his arms. We stopped, naturally, wondering what might be the matter. We were greeted with, "Hey, you guys, I want to see your hunting licenses." He had a Forest Service badge pinned to his shirt and, of course, had the right to ask. We thought the demand was rather odd considering it was long after legal shooting time and all our tackle was locked up in the trunk of the car.



Opposite: Roy Hoff leads the way, helping Ted Marak carry his deer into camp. Above: Floyd (Pete) Larraby of Los Angeles bagged the biggest buck during the hunt. It was a four-plus-three point buck.

Most of the fellows piled out of the car and presented their licenses for inspection. I kept my seat at the wheel because of a couple of game wardens had joined the ranger and were asking me how hunting was. Our conversation was interrupted with, "Wassa matter with you? Why don't you get out and show your license?" the wardens grinned, probably wondering what my reaction would be. Perhaps I felt a little ornery or maybe I didn't like the insinuation. In any event here's what I said:

"I'm sorry, sir, but when a bowhunter is not hunting it doesn't occur to him to show his license. Not one of us is hunting. The legal deadline passed half an hour ago. However, I am not reluctant to show my license. If you'll step back to the rear of the car I'll be glad to oblige." I unlocked the trunk, took out my quiver, unzipped the pocket and produced the license with the following remarks: "You see, when we're not hunting, we have no use for this stuff and lock it up. It just clutters up the car. However, when I am hunting, I always carry this quiver of arrows with my license in the pocket. Here it is."

He examined it carefully and handed it back. He didn't say anything, but if looks could speak he probably said, "Smart guy!" It wasn't that. It was the unnecessary procedure he used. Earlier in the day, we had visited the camp of Erwin and Delmer Pletcher. They told us an unbelievable story of being harassed by the same fellow.

The Pletchers both were professional men; each with a dental office in Bakersfield, Calif. They were late leaving the office and after a 300-mile trip arrived at their camp site on nearby Cold Creek after midnight. They made no attempt to set up camp, merely dragging out the sleeping bags and preparing to get a little shut-eye before daylight. Before they could get into their respective sacks, here came the ranger and demanded to see their hunting licenses. Erwin said he was too tired to argue with the man, but he expressed an opinion which I'm sure you will agree: "I've heard of a lot of strange things, but I never heard of anybody hunting with bow and arrow from a sleeping bag!"



## Compare... Your King dealer did!

Quality sells.  
That's why leading archery  
dealers recommend King  
accessories like  
the handsome  
#409 quiver.

### FEATURES:

- New SCORE CARD pocket.
- Double leather-stitched  
hang straps with belt clips.
- Pencil pocket.
- Divider strap makes  
2-division quiver.
- Large zipper pocket (8" x 3 3/4" x 1 3/4").
- Black or Brown.
- Right or left hand.

### DIMENSIONS:

20" Long; top opening 4 1/2" x 2";  
bottom 3 1/2" x 2".



#409  
Dealer  
inquiries  
welcome.  
Write for  
folders.

# KING SPORT-LINE CO.

328 S. Cypress Ave., Alhambra CA 91801

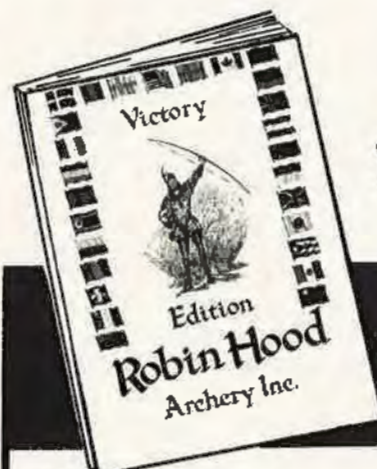

**FREE**  
WORLD'S LARGEST  
ARCHERY TACKLE  
CATALOG

**NEW**  
VICTORY EDITION

Compare our prices to any other manufacturer's. We do not have over-inflated prices. Check with your local dealer for our merchandise or send for our catalog.

MAIL THIS COUPON TODAY

**ROBIN HOOD ARCHERY INC.**  
215 Glenridge Avenue  
Montclair, N. J. 07042

Please reserve a FREE copy of your Catalog  
as soon as available.

Name .....

Address .....

City .....

State ..... Zip .....

Please print clearly

AM

## Chapter Four: Hunting Where They Almost Ain't

**BOWHUNTING** has been billed as the game of the dedicated sportsman who is more interested in the hunt than in the kill. To a degree this is true, but only to a degree.

If it were completely the case, bowhunters would be most prevalent in those areas where hunting is most enjoyable and stalking would be the predominant technique. We all know these latter two contentions to be untrue.

Bowhunters flock to those places where deer are abundant even though the area may be crowded. Bowhunters ambush deer from trees, a far more effective method than trying to sneak up on an alert whitetail or mulie in a noisy woods.

In other words, once having chosen to hunt with the bow, the average bowhunter tries everything he can to increase his chances of success. This leads to my conclusion that many bowhunters hunt with the bow because the bow season is open and the gun season is closed!

But bowhunters who feel this way don't, for example, take their bows into the Adirondack Mountains. For, by comparison with the bowhunting hot-spots of the East, the Adirondacks deserve billing as one "place where they almost ain't".

### More Enjoyment Than Success

I can list a variety of reasons why I spend some of my precious vacation days hunting in the Adirondacks nearly every fall but they all sum up to greater overall enjoyment in spite of less success. The possibility of encountering a bear also enters into the choice, but principally it is the ability to roam almost anywhere, encounter almost no one, watch the trout in their spawning colors in the small brooks, see a sky full of stars and free of pollutants, camp out and cook over a wood fire, and so many similar experiences that call one back each fall. The occasional successful encounter with a deer is simply frosting on the cake.

Actually, I consider we've had good luck bowhunting in the Adirondacks. Over the past ten years I've spent 37 days bowhunting on seven trips and taken two deer. In New Jersey I've taken 16 deer in about eighty days of hunting over twenty years. Mathematically, one can show that hunting success in New Jersey is 3.7 times greater than in the Adirondacks.

But, correcting to the last ten years to insure more comparable hunting and shooting abilities, the

## Biography of One Bowhunter



Continuing a book-length series by our bowhunter-in-residence, Dick Sage

factor in favor of Jersey is more like five to one. Still, I would find it a hard choice if I had to select one or the other location to hunt hereafter and forever. The truth is that I enjoy hunting in both areas — but for different reasons.

Wilderness hunting—and I believe the areas I hunt in the Adirondacks qualify for this description — requires a totally different approach than does the so-called "farm fringe" of New Jersey. For one thing there are fewer deer per square mile and deer sightings are related to density in an exponential manner.

For example, if a hundred deer per square mile produce twenty sightings per day, reducing the concentration to fifty per square mile very likely reduces the sightings to perhaps four or five rather than ten as might be inferred from the original 100 to 20 ratio.

A second major factor is the longer time required to learn deer movement patterns in these areas. My experience in a new area has consistently been increased sightings, and thus more shooting opportunities, at the end of each trip. The reason is clearly that we had located the animals and had a better idea how to get close. One should not overlook the tremendous advantage afforded in many populated areas by being able to easily locate deer concentrations by frequent trips, particularly at night by car. Those deer will not be far away the next morning. Such activities are next to impossible in a wilderness area and as a result it takes a long while to learn how to hunt any given location.

At least for an initial period the bowhunter is required to hunt by stalking until the whereabouts and habits of the local herd are reasonably established. Food concentrations such as orchards and winter wheat fields usually don't exist when you're

hunting well off the beaten path. The bowhunter must spend more time locating the areas where deer feed and bed before he can construct stands if he wishes.

### Corner Grocery

Also, the basic food of the wilderness whitetail is browse which is most prevalent in and adjacent to cut-over or burned-over locations. But in a remarkably few years the forest canopy is re-established and the low level growth subsides. When this happens, it is like closing the corner grocery store and the deer have to shop elsewhere for their meals.

One favorite spot of mine suffered this fate. Located in the triangle bounded by the Hudson and Boreas Rivers and the Minerva-Mink Pond road, it was cut over in the mid-1950's and by 1960 it was no trick at all to spot eight or ten whitetails in a day's hunting. One day I saw twenty-seven and while this may not seem exceptional for "farm fringe" hunters, I can assure you it was phenomenal in the Adirondacks.

We had a tent platform nearby and began an annual pilgrimage, initially with good success. But by 1967 the bloom was gone and in 1968 I saw nary a deer in two days of hard hunting. Clearly, the food supply had simply grown to a height where it was not as available to the deer and they had shifted to other feeding areas.

Now this doesn't mean there are no deer for there are. We see tracks and occasionally see one during our trips in to fish for trout in the Hudson. But the numbers have so decreased as to make bowhunting very non-productive. In spite of this I still try to hunt in there for a day or so each fall — deer



or no deer. It's fun just to be in that location.

How does one hunt these areas with any hope of success? Probably the most critical factor is proper mental attitude. The bowhunter must reconcile himself to two facts.

First, he must persevere in his hunting even though he sights few, if any, deer in the first few days. This is critical because otherwise, carelessness will creep in and deer that might have been seen will be prematurely spooked before the hunter is in sight range.

Second, he must be able to roam safely for considerable distances searching for deer signs which will clue him to the deer movement patterns. This roaming can be the key but it also can produce a lost hunter destined to spend one or even more nights alone in the woods. This last factor ties many bowhunters to the immediate vicinity of their camps and greatly reduces their chances of success.

It takes guts and ability to stay on stand at a good deer crossing until dusk knowing that camp is a mile or more away on the other side of a very dark cedar swamp. The usual result is that when the deer does arrive at the crossing, the hunter is well on his way back to camp. This may be wise but it is not very productive.

The wilderness bowhunter must also be much more careful not to overly alarm the deer in the area he hunts. You can literally spook a whitetail out of his usual haunts by the activities of maintaining a camp in an area where peace and quiet have previously prevailed. At best the local deer will become more nocturnal than would otherwise be the case. The reason, of course, is that such animals are simply not accustomed to strange noises and people and they react accordingly. In contrast, deer of the farm fringe experience frequent, even daily, encounters with man and his many activities. They are not unduly scared although they remain alert at a respectful distance until the disturbance is at an end.

#### Deer Less Alert

It is my opinion, however, that the wilderness deer is less alert than his country cousin who lives in the local farm woodlot. This may seem to contradict the previous paragraph but there is a fine line of distinction. While less alert the wilderness deer is nevertheless more disturbed once he is alerted and takes more drastic evasive actions.

Such deer can be stalked more successfully if seen before they are alerted. While they do not seem to recognize the human form as readily, particularly if it is not moving, they do seem more alarmed by noise. For these reasons I opt in favor of drab woolen clothing that is quieter in contrast to the less visible but noisier camouflage clothing which is my choice for farm fringe hunting.

When I think of wilderness hunting I think of a

**The wilderness bowhunter  
must persevere, roaming  
for considerable distances...**

most enjoyable week that I spent with two companions at Round Pond, almost in the shadow of the Adirondack's High Peaks region. The spark for this trip came from my son, who had worked summers at the Huntington Wildlife Forest just to the south. Particularly, it came from the extensive bear sign he had observed and we hoped for a crack at a bruin as well as at a whitetail.

There are only two ways to get in there, an eight mile hike from Long Lake or by plane. We chose the latter because Adirondack weather can be miserable and our "minimum" camp would have required at least two round trips in both directions.

Our camp was adequate but not fancy. We had two Baker tents, one for gear and a larger one for sleeping. We had a protective fly for the sleeping tent which proved a godsend when six inches of wet snow doused us on the fourth night.

Each morning we departed camp, lunches in our rump packs, with plans to assemble at some point for lunch and a comparison of notes. Although we hunted separately, we tried to coordinate our routes to avoid interference while still taking advantage of the others' presence as "silent drivers." At times we were three to four miles from our camp. Although we occasionally got misplaced, we always managed to meet when planned and return to camp before dark.

This was a fortunate trip because we got a pretty good feel for the deer locations the very first day. Still, it was four days before we managed to put any venison on the meatpole. We saw deer and had a reasonable number of shots and we also saw a bear and got a crack at that too. In my own case, I had several good opportunities.

Mainly, however, we'll recall the trip for instances others than our bowhunting success. The camp was secluded and quiet and the geese going south frequented the lake each night. We went to sleep hearing them talk to each other. We spent hours each evening in front of our fireplace, warm in spite of the cold and often wet weather. We ate good, slept good and generally had a ball. That we got a deer, and had a shot at a black bear, was simply the frosting on the cake.

#### Response to Weather

Weather is a primary variable in hunting wilderness areas for it is the thing to which animals do respond, usually in predictable ways once they are figured out. Each type of weather brings its own response, imposed on top of the usual seasonal, diurnal and other "regular" events in a deer's life. This problem of weather greatly complicates hunting strategy and can totally wipe out a hunt.

On the other hand, weather can be an invaluable aid once the reaction pattern is established. On the Round Pond hunt referred to earlier, the one deer taken was the result of correctly predicting the reaction of the deer to a sudden all night and early morning snow storm. Because other influences are lesser factors, the weather responses of wilderness game animals can be isolated and predicted more readily than in areas where more people are present



Author Sage checks a bear bait at Shining Tree Lake, Ontario, in 1968.

and events are more erratic.

It seems safe to say there is no easy sure way to hunt a wilderness area for the first time. The key is experience and that comes only from hours, days, even weeks afield in a particular location.

The more you know about the animal, the quicker you can become effective. But even the pro needs a day or two before he can begin to hunt a new area effectively. It is even hard to pre-scout many wilderness areas because seasonal factors can radically disrupt movement patterns of late summer and early fall. A good crop of beechnuts, or acorns, will cause the deer to completely revise their feeding schedules and locations.

I place a fair amount of stress on detailed study of a good topographical map of the area, preferably the 7½ minute series with a scale of about two inches to the mile. If you have a general knowledge of the forest cover, you can usually make some pretty fair guesses as to where deer may be bedding and feeding. At least it gives you a clue to work and in the bargain, you develop a keen awareness of the topography that allows you to hunt more freely with less concern about becoming lost.

#### Learning a New Area

Obviously one of the best ways to hunt a wilderness area is to do so with a partner or guide who really know what he's about. This is seldom done by spending a couple of days hanging onto the coattails of another hunter. Rather it requires time pouring over a topo map with each potentially promising area marked. It involves listening while the knowledgeable person explains his hunting techniques and recounts some of his local experiences. Then you go out alone and work these areas for yourself, for while others can assist, only you can learn how to really hunt a new spot.

I would consider bowhunting for whitetails with a guide to be pretty tough because so few guides have any appreciation of the limitations of the bow as a weapon. They can bring you to the area; they

can silent drive to move deer in your direction; they can keep you from getting lost, help you drag out your kill, and generally be an assistant; but the real tough part of bowhunting — getting close and making the shot — is up to the hunter himself.

I'm particularly leery of the value of guides in areas where the law requires you hire one. In many instances it's a "make-work" project and while the motives are nobile and the costs reasonable, the guides are often neither of these things.

I once hooked up with an outfit for a spring bear hunt that provided a father-son team that didn't know the area, nor did they know the first thing about spring hunting for bears. We actually got lost one day within a hundred yards of the logging road we walked coming in. Only by brute force did I convince the guide to go in the direction I knew to be right and he even continued arguing when we reached the road.

In spite of these things there are places where guides are needed and there are guides that can really help. Our Colorado bowhunt for mule deer was one of these situations and without doubt we greatly profited. But these guides used bows themselves and they knew what to do. We didn't tag each other all over the landscape. They took us to each area, explained the terrain and the expected deer locations and the probable behavior of the animals. The rest was up to us and they were available to help bring out the game if we succeeded.

Yet even with all this I find something is subtracted from a hunt where guides are used. The real satisfaction comes in solving the problems yourself, and in particular, going into a totally new and unfamiliar area and finding the key.

The problem is that this learning process takes time, often if not usually more time than the hunter can spare. As a result, when my time is limited and the trip costly, a guide is a necessary investment. But I still recall the low-cost eight or nine-day Adirondack wilderness hunts which were every bit as enjoyable, if somewhat less successful, as any other.





## GOT THE POINT?

If You Haven't —  
TRY SOME OF OURS!

The gun barrel bluing and close fitting shoulders will really SHARPEN up your arrows. A little more expensive, but a lot nicer.

25 styles and sizes to fit your every archery need.

### SWEETLAND ARCHERY PRODUCTS

1010 ARROWSMITH STREET  
EUGENE, OREGON 97402  
TELEPHONE (503) 348-0928

### NEW 1973 DELUXE KWIKEE KWIVER

light, compact, durable streamlined—good-looking on bow

- Permanently attached spring wire clip. • New propylene reinforcement plates guaranteed against breakage. • Riveted construction—strength without bulk.
- New G-3380 cores grip arrows firmly yet permit easy removal.
- Serrated bulldog grip on bow limbs.



Only \$3.95 at better dealers everywhere. Snap-on or off bow in a second.



**KWIKEE SILENCER**—Better than ever. 20% more sound absorption than any other silencer. Game will not flinch or jump at string twang. \$1.00 per pr.

**KWIKEE KWIVER** "the quality line"

KWIKEE KWIVER CO., 7202 Pencil Valley Road, Acton, Michigan

Limited Men						
1. Pickering, Jim	Salt Lake City, UT	292	288	293	873	\$500
2. Chaney, Duane	Woodside, CA	292	286	290	868	\$225
3. Schooler, Rod	Klamath Falls, OR	288	289	291	868	\$225
4. Erlandson, Roger	Sacramento, CA	282	288	294	864	\$150
5. Bennett, Harold	Trenton, MO	283	288	288	859	\$125
6. Blankley, Rod	Albuquerque, NM	283	283	289	855	\$100
7. Helgason, E.O.	Waseca, MN	290	286	272	848	\$ 75

Limited Women						
1. Hagemeyer, LaVonne	Edina, MN	272	271	269	812	\$250
2. Killian, Midge	Portland, OR	273	272	262	807	\$125
3. Jepson, Jean	Grand Island, NB	269	266	262	797	\$ 75
4. Kuhlmeier, Beryl	Des Moines, IA	264	274	248	786	\$ 60
5. Bourquin, Joyce	Mesa, AZ	262	252	253	767	\$ 50
6. Rhodes, Marion	Glendale, AZ	251	257	258	766	\$ 40

### BAREBOW BONUS MONEY

Men		
1. Gorr, Steve		\$150
2. Vogt, Cal		\$100
3. Hughes, David		\$ 75
4. Stuart, Gary		\$ 25

Women		
1. Girton, Susan		\$ 75

### JUNIOR OLYMPIC

Name	State	1st rnd	2nd rnd	Total
<b>Intermediate Boy</b>				
1. Drabek, Michael	Phoenix, AZ	536	534	1070
2. Riley, Gary	Cedar Rapids, IA	536	534	1070
3. Woody, Ken	Des Moines, IA	532	536	1068
4. Wilson, Barry	Phoenix, AZ	529	538	1067
5. Roles, John	Phoenix, AZ	534	532	1066
6. Losey, Rob	Lansing, MI	521	534	1055
7. Mercill, Mich	Jackson, WY	524	518	1042

<b>Intermediate Girl</b>				
1. Brown, Jody	Terrance Park, OH	532	534	1066
2. Thompson, Debby	Phoenix, AZ	502	490	992
3. Bartunek, Nancy	Grand Island, NB	471	480	951
4. Howell, Gail	Jonesville, MI	494	455	949
5. Cavanaugh, T.	Albuquerque, NM	406	432	838
6. Yorgason, Carol	Jackson, WY	428	452	880
7. Wallace, Roberta	Nogales, AZ		474	474

<b>Junior Boy</b>				
1. Miller, Bill	Glendale, AZ	514	500	1014
2. Allison, Brad	San Gabriel, CA	490	522	1012
3. Dolamore, Jim	Phoenix, AZ	508	496	1004
4. Bosley, Clyde	Phoenix, AZ	482	508	990
5. Slotta, Jeff	Phoenix, AZ	516	432	948
6. Wopschall, Wayne	Covina, CA	457	468	925
7. Sands, Steven	Phoenix, AZ	456	458	914

<b>Junior Girl</b>				
1. Allison, Heidi	San Gabriel, CA	498	494	992
2. White, Cheryl	Phoenix, AZ	456	480	936

## NOCK-RITE BOWSTRING ATTACHMENT

FOR FAST ACCURATE SHOOTING . . .

- Balanced three finger action
- Smooth arrow release
- Satisfaction guaranteed \$1.00

Available at archery and sporting goods dealers—archery manufacturers—jobbers—distributors—or write

**NOCK RITE COMPANY**  
3720 Crestview Circle  
Brookfield, Wis., U.S.A. 53005



## COMING EVENTS

### \* March 31-April 1

Valley West Archers will host their Golden Fleece open tournament beginning at 9:30 a.m. For more information, contact: Bill Miner, 21001 Plummer St., Chatsworth, CA 91311, telephone (213) 341-6384.

### \* April 14-15

The Indiana State Indoor Championships will be held at Ball State University in Muncie. Team championships will be held on Saturday and individual competition, on Sunday. Pre-registration deadline is April 1. Out of state visitors are welcome on both days. For more information, contact: Jim Carter, 2016 Medford, Indianapolis 46222.

### \* April 28-29

The 1973 Fresno Safari will include a guaranteed \$1,000.00 purse for archers wishing to shoot for money rather than trophies. Pre-registration fee is \$20.00 for the money shoot, postmarked on or before April 20. Cash awards will be \$800.00 to two places for men, \$200.00 paying to five places for women. Money shooters will be grouped together and assigned consecutive targets. Contact: Al Gean, 3323 E. Belmont, Fresno, CA 93702.

### \* May 19-20

The Virginia State Open Field Championship will be hosted by Wythe Bowhunters, Wytheville. They are located nine miles north of Wytheville on Rt. 21 and 52 off I-81, and four miles west of I-77 from Big Walker Mt. tunnel. The competition will be 28 field and 28 target. For more information, contact: Harold Street, Rt. 4, Box 133, Wytheville 24382.

### \* May 19-20

Rocky Mountain Archery Assn. will hold its target tournament at Black Otter Bowmen, Billings, Montana.

### \* May 26-27

The annual Safari, which has been the largest archery event in Arizona, will be hosted by Broken Arrow Bowmen in Tucson. For more information, contact: Severo V. Palma, 1362 W. Simmons Place, Tucson, AZ 85705.

3. Whaley, Mary Beth	Lakewood, OH	447	476	923
4. Franzen, Lori	Jackson, WY	422	468	890
5. Richins, Lynette	Jackson, WY	366	396	762
6. Clark, Carol	Jackson, WY	347	383	730
7. Webb, Paula	Phoenix, AZ	353	351	704

### Cadet Boy

1. Powers, Christopher	Cincinnati, OH	490	504	994
2. Wollman, Mark	Sherman Oaks, CA	468	500	968
3. Cooper, Randy	Phoenix, AZ	338	348	686
4. Kouns, Scott	San Jose, CA	208	255	463

### Cadet Girl

1. Baxter, Sue	Klamath Falls, OR	380	392	772
2. Miller, Deb	Glendale, AZ	360	334	694
3. Webb, Pamela	Phoenix, AZ	300	341	641
4. Allison, Jennifer	San Gabriel, CA	324	300	624

### NFAA Winners

Flight # 1		
	Score	Prize
Gene Parnell	599	\$150*
Ellis Gibson	599	\$100
Blair Peterson	598	\$ 80
Ed Riggins	597	\$ 51.66
Wayne Sanderson	597	\$ 51.66
Tom Langston	597	\$ 51.66
Mike Stratman	595	\$ 20
Ron Fulkman	595	\$ 20
Don Douns	595	\$ 20
John Taylor	595	\$ 20
Wes Hagemeyer	595	\$ 20
George Miller	595	\$ 20

Flight # 2		
	Score	Prize
Gary Henspeter	585	\$100
William Dahl	584	\$ 70
Larry Crim	583	\$ 50
Bob Dunsmore	583	\$ 50
Rich Doughty	582	\$ 32.50
Roland Harrard	582	\$ 32.50
Bob Trumble	581	\$ 25
Charles Martin	580	\$ 13.33
Donald Ross	580	\$ 13.33
Donald Engle	580	\$ 13.33

\*Winner in Shoot-Off



"Among other things March winds mean spring huntin' is just around the corner. Gettin' ready means Bright Way ground base feathers — they are die-shape."

FIRST IN  
QUALITY AND  
RESEARCH

**TEXAS FEATHERS INCORPORATED**  
BOX 1118  
BROWNWOOD, TEXAS 76801



## CLASSIFIED ADVERTISING

### FOR SALE

TROPHIES, medals, ribbons, figures, shirts, jackets, emblems. Discounts. FREE Cat. NFA73 C.E.T., 116 Springfield Ave., Granite City, Ill. 62040.

NOCKS: Compare ours with any on the market. New butyrate nocks 100 for \$1.50; 500 for \$6.00 or 1000 for \$10.00 postpaid. Sizes 11/32, 5/16, 9/32 and 1/4 inch. Colors: white, red, yellow, green, blue, orange, and black. For price list and sample nock send stamped self-addressed envelope. **Blue Cloud Archery Co.**, 242 Walnut St., Ft. Collins, Colorado.

YEW WOOD ENGLISH LONG BOWS. Recurved bows, custom made. Tested and proven by over 1,000 years of use. Also, roughed-out staves, ready to tiller, \$3.50 and up. **Don Adams Marine**, Rt. 3, Box 241, Veneta, Oregon 97487. Phone 1-503-935-1893. tf

TARGETS. Complete line, Fast service. All NFAA - Field, Hunter, Animal, PAA, Chicago, Flint, FITA, NAA 4-color. Deer Safari, Small Game, Heart, Poker, Wilma Tell Novelties. Card-board, paper. Free catalog. **Finnwood Products**, Dept. A, 516 Mill St., Cincinnati, Ohio 45215. Phone: 1-513-761-0198.

### U.S. OPEN Continued from page 13

NFAA National by storm as an amateur. Now stationed in the Philippines with the Air Force, Gale caught hops all the way back home to participate and shot an 891 to garner 13th place in the championship flight despite some problems with glance-outs, which plagued a number of archers.

Other NFAA champions, former four-time barebow winner David Hughes, who appeared to be joining the impressive Carroll Bows stable of shooters, and Cal Vogt, current national bowhunter champion, battled for their shares of the Bonus Barebow purse, but were edged by Steve Gorr, of Denver, Colorado, who took home \$150 with his 821 score. Vogt, with an 815, slipped in front of Hughes, with an 815, to take second place.

In all, there were about a dozen bowhunter class shooters who turned out for the tournament with heavy tackle in hand. Most expressed a desire to compete head to head with the barebow shooters next year.

It was home-town favorite and archery great Lou Shine who

Rates \$1.10 per line per insertion. Minimum three lines. (Count 36 letters and spaces to the line.)

SENSABOUT BOW TUNING. Complete Info, System, Experiments. Surest Way to Improve Score. Small booklet, big results—\$3 Postpaid. **Emery Loiselle**, 316(AM) Cambridge St., Burlington, Mass. 01803.

BOW HUNTERS! Black Copperhead Custom "Slicer" - "Ripper" and "Magnum" broadheads. Immediate delivery. Write **Bowhunting**, 15705 Schaefer, Detroit, Mich. 48227. tf

WANTED: Old Broadheads. Collector will buy or trade. Write: **Scott Shoewalter**, Box 219, Parden City, Kansas 67846

### EMBLEMS

EMBROIDERED PATCHES: Washable fast color emblems made-to-order in lots of 10 or more. 100 Archery designs with exact prices and full detail sent free to clubs. **Anthony Emblems**, Box 7068, Grand Rapids, Mich. 49510. tf

showed them how at the first U.S. Open Slingshot Tournament, held in conjunction with the archery championships and sponsored by Saunders Archery Company. The Lady Named Lou combined a day's practice with natural ability to put enough lead into the revolving "action targets" for 145 points, which netted her \$150.

Norm Ekdahl, of Concord, California, took the open male title with 280 points for \$300, and almost every archer found his way over to the slingshot lanes to see what could be done. Naturally, someone showed up with a sight and stabilizer mounted on their slingshot, and somehow that piece of equipment found its way into Roy Hoff's hands.

On the subject of new equipment, there were some significant introductions at the Open. Carroll Archery Products offered the first public showing of their new compound bow. According to Bob Carroll, the hunting model should be ready in sufficient numbers to insure 30 day delivery after March 1. Carroll pro Gary Lyman is probably shooting his own tournament model as we go to press, but it

"How to Make a Bow String" book free with J.G. Hook Spin server. Just send \$3.50 to J.G. Server, 251 Four Seasons Dr., Waterloo, Iowa 50701.

ARROWS! 1 Dz. Aluminum with changeable point inserts \$17.95. Field points or BHA'S \$1.50/Dz. Postage \$1.00. **Jungle Jim's Bow Hut**, P.O. Box 1048, Slidell, Louisiana 70458.

ARCHERY DEER HUNT on the Book-cliffs with Gene and Harley Peters. 80 years combined guide experience. Box 1208, Craig, Colo. 81625.

FOR SALE TO HIGHEST BIDDER BEFORE MAY 1st, 1973. The following books, all in A-1 condition: **Archery the Technical Side**, Vol. 33 by Hickman-Nagler-Klopsteg, 1947 orig. **Turkish Archery and the Composite Bow** by Paul E. Klopsteg, 2nd edition, 1947. **Target Archery**, Robert P. Elmer, 1946. **Hunting With the Bow and Arrow**, Saxton Pope. **Introduction to Archery**, Marvin T. Schmidt. **Field Archery Technique**, Albert J. Love. **Shooting the Bow** Larry C. Whiffen. **Archery - The First Chapter**, Olive Besco Layer. **Archery Official Handbooks**, 1945-46, Sixth Edition, 1953, Ninth Edition, 1956-57. Send your bid to: **Bernie Dresden**, Box 703, Zapata, Tex. 78076.

may be as late as May before the magnesium-handled tournament bow production is sufficient to begin meeting demand. Jennings Compound also chose the Open to introduce a new lifetime metal handle which features hardwood grips and reduces their total bow weight to 3½ lb.

Last, but far from least, the Open was the meeting site for members of what was to become the NFAA professional division, as reported on elsewhere in this issue. So, along with the introduction of what we hope becomes a traditional NFAA money shoot at Las Vegas, it was a very successful tournament for NFAA members, as it was for all who attended. A tip of the hat to sponsors Easton Aluminum, Shakespeare Archery, Saunders Archery, Bow and Arrow Magazine and the Desert Inn for a job well done.

**JOIN THE NFAA  
THROUGH YOUR  
STATE ASSOCIATION**

# THE COOL COWBOY BLEW THEIR MINDS IN LAS VEGAS

Gene Parnell, that cool cowboy from Wyoming, put together a 898 out of 900 scoring inside-out on the difficult Las Vegas round. Then he topped it off with 56 out of 60 in the most spectacular shoot-off Vegas has ever seen.

You may not shoot these scores your first pro tournament but we guarantee the advanced design of the **Spartan II** will meet any test the serious shooter demands.

It's that simple. When people who love archery make a bow, they build it to last through win after win. Let this be the year the **Spartan II** does it for you!



**Spartan  
Archery Co.**

2465 4th Ave. No.  
Seattle, Washington 98109

1973 Champion, Gene Parnell, won't shoot any bow but a **Spartan**. "The best shooting bow on the market."



# MILETRON

**50% MORE AIMING POWER!**



***Aiming Power  
To Help You  
Shoot Better  
Than Ever  
Before!***

At the Las Vegas Open, January 1973, the Miletron Scope Sight came in 1st, 2nd and 3rd! It has also chalked up wins of 1st and 2nd at Las Vegas '72, 1st place Fresno Safari '72, 1st, 2nd, 3rd, Las Vegas '73, 1st place Bear valley '72, and many, many more wins in state and local tournaments!

It's exclusive magnifying aiming system incorporates a **specially ground and polished glass lens!** (Not plastic, which scratches and blurs aiming.) Now — you can see the target, aiming dot and recessed bubble — **all at the same time!** And best of all — **the Miletron is complete and ready to use!** No parts to assemble, nothing to rattle or unscrew. The Miletron is constructed of highest quality aluminum and stainless steel. The Bubble level is recessed for maximum visibility in any lighting condition. Fits most all sight bars and its unique design allows instant locking adjustment. Insist on the winningest sight of them all — the Genuine Miletron Scope Sight.

**NFAA APPROVED**

**MILETRON  
PRODUCTS**

The Miletron Scope Sight is sold at leading Archery Pro Shops everywhere.  
Distributed by Easton Aluminum Inc., 7800 Haskell Ave., Van Nuys, Calif. 91406