

March 2025

www.nmra-scwd.org

Volume 56 No. 7



Superintendent
Art Dawson sends his
apologies as there will
be no column this
month because of his
severe winter cold!

Next SCWD Meet
Verona Senior Center, Verona
March 2, 2025 at 1 PM

Next BOD Meeting:
March 11, 2025 at 7 PM
ZOOM Meeting



Next Youth Group
Verona Senior Center, Verona
March 8, 2025 1 PM



Youth Group

Steve Preston, Chair



Not much new happened at this month's youth meeting. The kids did make good progress on their dioramas, and as you can see, they are coming along nicely. I and the rest of our team look forward to seeing what they'll be like when they are done.

Thanks Phil Hottmann for your time.

See you all next month.

Steve Preston
Youth Group Chair and
SCWD Membership Chair

Clinic Column

Bob Wundrock

Thanks to Keith Kohlmann and Phil Hottmann for their excellent clinics at the February 2nd meet.

Look to see Keith's modules at our Mad City show.

I'm still viewing some of the YouTube videos that Phil mentioned during his clinic.

One static grass technique that Phil didn't mention could be rubbing your shoes on a carpet before grass application. (Ha!)

On March 2nd we'll have two Wisconsinites doing presentations.

Our first clinician will be Craig Wright from Fitchburg. Craig will present "Modeling the Prototype (D&RGW), the Influences, the Design and the Results." His clinic will feature his Sn3 layout is intended to help inform layout visitors of the where, when, why, and how the layout came about.

His layout is on the layout tour for the day.

Our second clinician is retired architect, Jim Coady from Hudson. He will present "Wrong Island Rail Road, the 'Route of the Streaking Commuter'!"

Jim got back into model railroading after a long hiatus around 2005 and in retirement decided to build a layout that emulated what was his daily work commute for many years from Port Washington Long Island to New York City. The railroad was operational and presentable a year later. His clinic is about that journey.

See you virtually.

Bob



Modeling Project

Mike Vivion

This is just a reminder to all who signed up to participate in this year's modeling project that you have approximately one month to complete your project. Please plan to bring your finished project for popular-vote judging to our April 6th meeting.

Mike Vivion
Modeling Project Chair

FROM the NMRA Please Keep in Touch



Please make sure the NMRA has your current contact information. You will not be able to access the full range of NMRA benefits unless we can reach you.

- Please visit nmra.org/members
- Use your email address and password to log in.
- If you have not yet registered, or forgot your password, there are buttons for that. Take a moment to easily correct any problems.
- Once logged in, click on Member Info (top right corner).
- Make sure your information is correct.
- If not, please go to:

nmra.org/request-membership-info-changes

to submit a request for changes to be made.

Thank you!

For those members that participate in the listserv emails from Steve Lanphear, please remember to send him your new email if you change it! Changing your email with the NMRA does not change it on the listserv. His email is:

Steve Lanphear
SCWD listserv Coordinator
scwdmemberlist@mhtc.net



Layout Tours

Phil Hottmann

Well, it was just about 2 years ago that we last visited John Krueger's Great Northern layout. Surprisingly, even though a lot of work has been completed, a lot of it was not very visible. Almost all the work was done at an upper level about 72" off of the floor. This is going to be an incredibly large layout when completed! Can't wait to see more of the work completed and maybe someday doing some operations. Thanks to John for opening!



For March we will be visiting Craig Wright's "S" gauge layout(s). You probably have seen his narrow gauge layout in the past, he now has a standard gauge layout that as far as I know is not connected to the other. Not sure if that is the eventual plan. Craig will also be giving one of the clinics at the meeting, so that should add a lot of interest to the tour. I'm looking forward to this visit!

Phil

Contest Column

Dave Down, Chair

March is soon upon us, and if I was really into March our contest would probably be Irish Railroads. But no, we're not doing that. The March contest theme is **Open Freight Cars with Loads**. The categories are A - flat cars, B - Hoppers (open) and C - Gondolas. This is a chance for you to show off some of the interesting loads your railroad is hauling.

Also, looking ahead, in April we will have models for the modeling contest, so there will be no contest for the popular vote contests. There will be no contest in May since we will be having a joint meeting with the NMRA division in Rockford. They came here last May and they brought many contest entries. Hopefully we will have a good representation from our division. If you are planning to get involved in their contest, the theme is **Open Loads**.

February's contest was **Track Maintenance Equipment**. Here are the results.

February 2 Popular Vote Contest Results — Track Maintenance Equipment

- A. Maintenance of way rail cars
- B. Speeders or inspection vehicles
- C. Specialized equipment - rail grinders, tie replacers, etc.
- D. Other - anything that does not fall into categories A, B & C

Models

Cat. A Maintenance of way rail cars

1st Don Swinton: Flat Car and Caboose



Cat. B Speeders or inspection vehicles

1st Don Swinton: 2 man Hand Car

2nd Dave Casey: CNW #9 Speeder

2nd Dave Casey: CNW Ford rail pickup



Cat. C Specialized equipment - rail grinders, tie replacers, etc

1st Dave Casey: CNW #11989 Jordan Spreader

2nd Dave Casey: CNW #6415 Russell Snow Plow

3rd Don Swinton: Santa Fe Crane and service car



Cat. D Other - anything that does not fall into categories A, B & C

1st Dave Casey: CNW #9050 Transfer Caboose

2nd Dave Casey: CNW #X2636 Scale Tester



Photos - Prototype

Cat. PB Speeders or inspection vehicles

1st: John Haverberg: Westley Peats Speeder

2nd Dave Down: Museum Speeder - Heber, UT

3rd Dave Down: Gandy Dancer - Railroad Museum, Ogden, UT

Cat PC: Specialized equipment - rail grinders, tie replacers, etc

1st Dave Down: Rail Grinder - Provo, UT

Dave



Annual Election of the SCWD Board of Directors

April 6, 2025

Candidates in Alphabetical Order

Chris Bradley

I have been interested in model railroading for almost 40 years, since I was 10 years old. My father had just purchased a new AHM Locomotive (C&NW SD40) from our local Woolworth. That prompted him to bring out a train set that he got a couple years earlier. It was Tyco's "Steel Hauler" set. I received my own Life-Like train set the following Christmas. Yes, I think I still have most of these pieces in my collection. My father, brother and I were pretty happy just setting up and taking down various ovals on the floor for a couple of years. A trip to our local train show introduced us to the world of model railroading and layouts. From there we started visiting our local hobby shop "The Owl's Roost". In the basement was the local Club's modular layout that had become permanent. That led us to joining the Kankakee Model Railroad Club. This allowed us use of the layout on Saturday mornings.



My first layout was just a 4x6 sheet of plywood with a grass mat on it. I have had and been part of various layouts and modules over that time period. I have also contributed to many fellow model railroader's layouts along the way. I am in the finishing stages of the room that will house what I think will be my 7th layout.

I enjoy being a member of the SCWD and being a part of the meetings. I have been an active official member of the NMRA for the last 3 years. Previously, I had attended SCWD meetings sporadically over the last 17 years prior to that. I have also been a participating parent member and presenter of the Youth Group for the last 10 years. Other model railroading club experience includes being part of the Kankakee Model Railroad Club for about ten years in the 1990's, until other more grown up things became center focus for a few years. I got back into the hobby in 2002, the year after my wife and I bought our first home. This last year I was asked to be a part of the SCWD Board of Directors. I am looking forward to continuing in the role as a Board Member should you choose to keep me on the Board.

Thank you

Art Dawson

Like many others I had an HO train loop on a sheet of plywood when I was young, and mine had a slot car track in the middle of it too! As a child, my family road the Empire Builder out to Seattle (dome cars and all) with my two brothers and I dressed in red polo shirts. All mom had to do was ask any car attendant were we were, and they knew.



After forays into model airplanes, rockets and cars, then school, girls, and work followed by family took up all my time until my son was old enough to show some interest. By then I had learned that my grandfather and great-grand father worked on the section gang for the Nickle Plate in central Illinois. I've been hooked on that prototype ever since. As my son got old enough, we joined the SCWD youth group and participated in the show for a couple of years and attended meetings. When Hank Brown decided he was burnt out as Show Chairman, I asked what was involved one meeting, and if you knew Hank, he talked me into taking over as chairman. The rest was history as I had that role for 20 years.

Being back in the area for a few years now, and working the show office for the last two years, I decided it was time for the next step and agreed to run for the SCWD Board last year. I got elected, and have been honored to serve as your Superintendent. I will do my best to support the division going forward if re-elected.

Candidates continued next page

Dave Dingman

Interest in model and prototype railroading survived many challenging tests during the time following childhood/teenage fascination as college, multiple moves and work all limited participation to reading Model Railroader magazine, sporadic railfanning and going to model railroad shows. Repeated visits to the Mad City Model Railroad Show helped re-ignite my passion for model railroading.



I joined the SCWD and NMRA in 2016 to expand my knowledge of model railroading. Since becoming a member of the SCWD, I have become the AV Chair and have also been the Ticket Master for the Mad City Model Railroad Show for the last four shows. It has been my honor to have served on the SCWD Board of Directors (BOD) for the last four years. I would like to continue serving on the SCWD BOD for the coming year.

Dave Down

Hello SCWD members. My name is Dave Down and I am running for re-election to our Division's Board of Directors. I have been interested in model railroading starting with my first train when I was 8 years old. I had a large American Flyer set which was big enough to run around both our living room and parlor. My father also introduced me to HO trains when I was 12 when he gave me a refrigerator car (which I still have). While I was in college my parents moved and had an auction, which was the last time I saw the American Flyer. After that time I was pretty much a closet model railroader until I approached retirement.



During the next 45 years I read magazines, acquired some engines and cars, and started work on a couple different layouts. Work took me on the road and gave me too many chances to procrastinate, so when I approached retirement I set a goal of becoming a model railroader for real. I decided to become a member of the SCWD in the fall of 2015 with the goal of meeting and getting to know people who have already had success in the hobby, and to find which aspect of the hobby will give me the most satisfaction. As a result, I have acquired a model railroad layout based on the Soo Line (Bill Ehlert's Rugby Junction).

I believe the SCWD is most successful when it provides modelers the opportunity to find and develop their interests. For some, it is operations, for others it is modeling engines or rolling stock, and to others it is modeling scenes, and some just like to collect railroad artifacts and models. Personally I find myself drawn to railroad stations and to railroad history. It is my goal to help the SCWD continue to encourage modelers find their interests and expand their interests and skills in the hobby.

Sean Hadfield

Like so many others, I got my first train for Christmas around the age of six. This was the 1970's, and it was an HO scale Lifelike ACL 4-6-2 with 2 circus wagon flatcars and 2 Rivarossi old-time coaches. I still have those, and I've continued collecting for the next 50 years.



I went on to become a civil engineer, probably because I love creating layouts so much.

Originally from Chicago, I first joined the NMRA in Glenview at the now-defunct North Shore and Western Division, when my wife and I bought our first house nearby. Later when we moved to Madison and started raising kids, I would occasionally check in at SCWD meetings and Region conventions.

Now a full member again, I chaired the Rail School for 2025 and helped at the Show Office at the Mad City Train Show the same year.

I am now running to become a first-time member of the SCWD Board of Directors, to help in keeping this beneficial and vibrant organization running along.

Candidates continued next page

Bob McGeever



My wife and I have been rail fans all our lives. I got interested in model trains as a kid when my dad gave me and my brother his childhood Lionel train set. I spent the first 30 years of my married life intending to build a model railroad. My boys and I went to the train show every couple of years and dreamed of what we could do with half the basement. Time passed, the boys grew up and I found I finally had the time to build a model railroad.

I started the planning a layout about 12 years ago. I'm working in N scale using the WSOR as my prototype. It supports my interest in lots of local freights in limited space, it runs through the town I live in, and I really like the color scheme on their locos. After we retired and added to the house, I had twice as much basement to fill. The expanded layout has almost all the track installed. I have developed an operating system using JMRI Ops Pro. Some of the scenery is done. I have lots of structures to complete. But it runs!

I joined the NMRA in 2010 to learn from other people with more experience. I have had the honor of serving on the BOD since 2011 as the Clerk and the Superintendent. I currently serve the SCWD as Paymaster and as the Train Show Committee Chair.

Steve Preston



Thank you all for voting me in on the board for the past several years. I have had the opportunity to see what goes on in our organization and I am proud to have been part of such an important role in our division. I hope you will keep having confidence in our board's leadership, and trust. I will continue to serve and help our division grow, given the opportunity.



It's banquet time!

May 9th 2025

To be held at the:
American Legion Hall
207 Legion Street
Verona, WI 53593
Cocktails at 6pm



Dinner will be served starting at 7pm — so don't be late.

Reservations must be received by May 1st

Cost of meal: SCWD/NMRA members, \$15.00

Non-NMRA attendees, \$25.00

Children 12 & under, \$5.00

Name:

\$

Note: If you are an NMRA member, your spouse, child over 12 or significant other is the same price as you.

If more than 4 then add to a separate piece of paper and send it along with your reservation.

Address: _____

City: _____ WI Zip _____

Send your reservation to:

Art Dawson
16317 W. Union Rd.
Brooklyn, WI 53521

Amount enclosed: \$ _____ Checks should be made payable to the SCWD



SCWD 2025 Annual Summer Picnic

Saturday, July 12, 2025



For the past several years, except for 2020, the SCWD has held a catered picnic at Little Amerricka Park in Marshall. The SCWD Board has agreed to do so, again, this summer on Saturday, July 12. Reservations have been made with the amusement park for use of their Blue Rose Pavilion and catering is being provided by Angelo's, used in 2024. The park opens at noon and closes at 5 pm. Lunch will be served starting at 12:30 pm. As was done in 2019, 2022, 2023, and 2024 the Board has decided to defray part of the catering cost by charging a \$5.00 fee for each attendee, six years old and above. Five and under get the meal for free. Railway equipment can be viewed for free, but train and other rides require purchased tickets from the Park. SCWD members and their families, Youth Club members and their families and other invited guests, approved by the Board, can attend the picnic. To determine the food quantities for the caterer, you will have to sign up and pay by July 1, 2025. Please indicate ages for kids under 12 to help in planning for quantities for kid's meals. Little Amerricka is located on STH 19 on the east edge of Marshall. Parking directly at the Blue Rose Pavilion can be reached off Box Elder Rd. intersecting USH 19 just east of the Park's regular entrance.

Added Attraction Roy Grant will have his N-scale, Omaha Western layout open from 10 am to noon on July 12th. The layout in his house was on display prior to the 2017 picnic. He has now rebuilt the layout into a separate building. His property is about 2 miles west from the first intersection north of I-94 on STH 73 at West Medina Rd. The address is 1465 West Medina Rd., Deerfield, WI 53531.

SCWD 2025 Annual Picnic Sign-up and Payment Sheet

SCWD Member and Family Attendee names and ages for those under 12 years old

Cost(each):

Total Enclosed \$ _____

Please print and fill out the form and send with payment (cash or checks - payable to the SCWD) by 7/1/25 or bring the sign-up sheet and payment to me at a future SCWD monthly meeting. My address is:

John Haverberg, 4797 Delmara Rd, Middleton, WI 53562

Any questions, contact me at E-mail address: haverdj@tds.net, Phone: 608-836-7963.



Congratulations to our Train Show Layout Winners



Best in Show Santa Fe All the Way Modular Layout



1st Place G Scale/Hi-Rail Badgerland S Gaugers



**2nd Place
G Scale/Hi-Rail
Dave Schoedel Layout**



**3rd Place
G Scale/Hi-Rail
WisLUG**



**1st Place
HO Scale
Midwest Mod-U-Trak**



**2nd Place
HO Scale
Kettle Morraine Ballast
Scorchers Railroad Club**



**3rd Place
HO Scale
Milwaukee Operators
Organization**



**1st Place
N Scale
MODUTRAK N Scale**



**2nd Place
N Scale
Capital city "N" Gineers**



**3rd Place
N Scale
Milwaukee-N-Southeastern
Model Railroad Club**



**1st Place
Z Scale
WIZ KIDZ**



**2nd Place
Z Scale
The Royal Train**



**Many thanks to the 2025 Layout Judging Committee
Dr. Bill Clancy (not pictured) and Ken Hojnacki Co-Chairs
Keith Thomsen, Phil Hottmann, Larry Goss, Marc VanCleven, Al Potts, Ken Hojnacki,
Sean Lamb and Ron Halvorson**

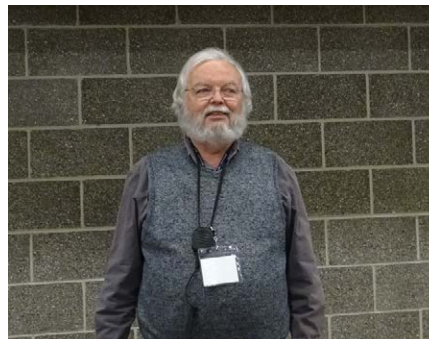
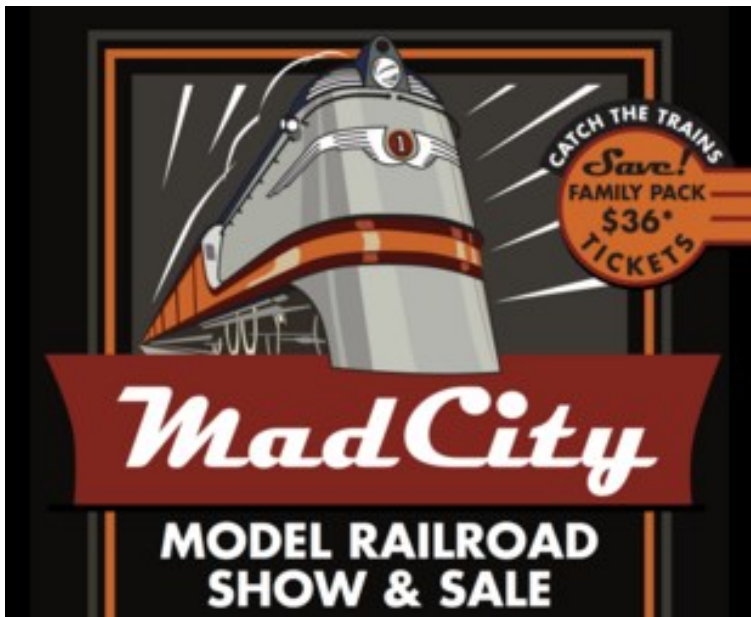

Bob McGeever
Train Show
Chairman



Dave Down
Volunteer
Chairman



Steve Preston
Youth Group
Chairman









**Many thanks to the
Company Store for all their
hard work for the SCWD!**



Some of the (very happy) Train Set Winners

Photographs by Mike Vivion



A Puzzle for You

You like trains, or train watching, but have you ever wanted to go to an OPS (Operating Session) and run trains on someone else's layout, but were afraid you wouldn't know what to do?



Model Railroad Operation is a fun and interesting role-playing game where the players (operators) use model trains to simulate the movements of the prototype railroad. Operators fill the roles of railroad employees like engineers, conductors, yardmasters, dispatchers, and more. Many of our SCWD members participate each month at multiple layouts to enjoy this fun and stimulating practice of critical thinking and problem solving in the context of railroad operations.

Now, there is a way for you to get your feet wet in this critical thinking and problem-solving railroad environment in the privacy of your own home through the use of railroad switching puzzles.

In July 2020, a group of SCWD members started a project to introduce more of our members to the enjoyment of railroad operations, or as our wives call it, playing trains. Some of us have been engaged in operating sessions for 20 years or more, and would like to get more of you involved.

The project involves getting one to solve a series of train switching puzzles (on paper, or your computer) in the least number of moves possible. You can then submit your solution to see if yours was done in the least number of moves.

Beginners can start with **3 introductory puzzles** to show the kinds of skills used in railroad switching operations. Then, you can advance to a series of more advanced puzzles written and based on actual SCWD member area layouts. Or, if you have already been to an OPS session, you could do an introductory puzzle, and jump right into the more challenging ones.

Join the SCWD listserv now and begin learning what this is all about!

Email Steve Lanphear at scwdmemberlist@mhtc.net to be added to the list and start receiving your puzzles now!

Happy Railroading!
Steve



Enjoy receiving interesting rail photos, model railroad tips, Operating puzzles, and challenging Mystery Photos??

Join The 120+ SCWD members and members from other Midwest Regional Divisions who are participating in the SCWD listserv. You can expect 5 - 10 photos of railfan photos or model railroad photos or other items per week on average, as well as SCWD announcements, monthly Mystery Photo contests, Modelers Corner, and OPS Corner Puzzles. The listserv has been running this since April 2012, and it has been quite popular.

The listserv is a one-way email broadcast to you, not a social media type service. The emails are sent in bulk, but as a BCC: type email.

Please save this email so you know how to get a hold of me. So, if you would like to try out this FREE member service, just send me your **Name** and **email address**, and **City/State** to the address below. You may drop out at any time by sending an email stating such to the same address below.

Steve Lanphear
SCWD listserv Coordinator
scwdmemberlist@mhtc.net



OPS Puzzles

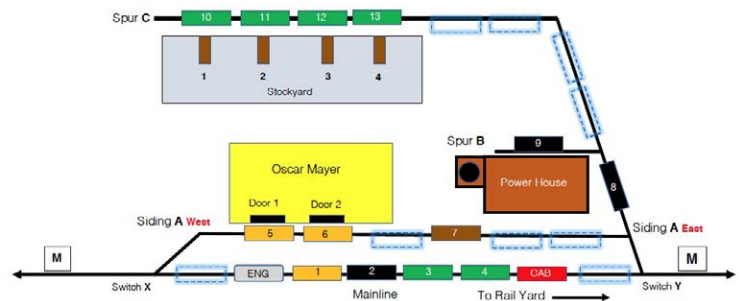

OPS Puzzles have arrived! We now have a section on the SCWD Website that has all 11 puzzles that we have published on the listserv, including the handouts and diagrams. You can start from the beginning, or pick and choose which puzzles you would like to try.

www.nmra-scwd.org/ops-puzzles.html

Steve Lanphear and the Puzzle Development Team.

Verona Senior Center
108 Paoli Street
Verona, WI 53593

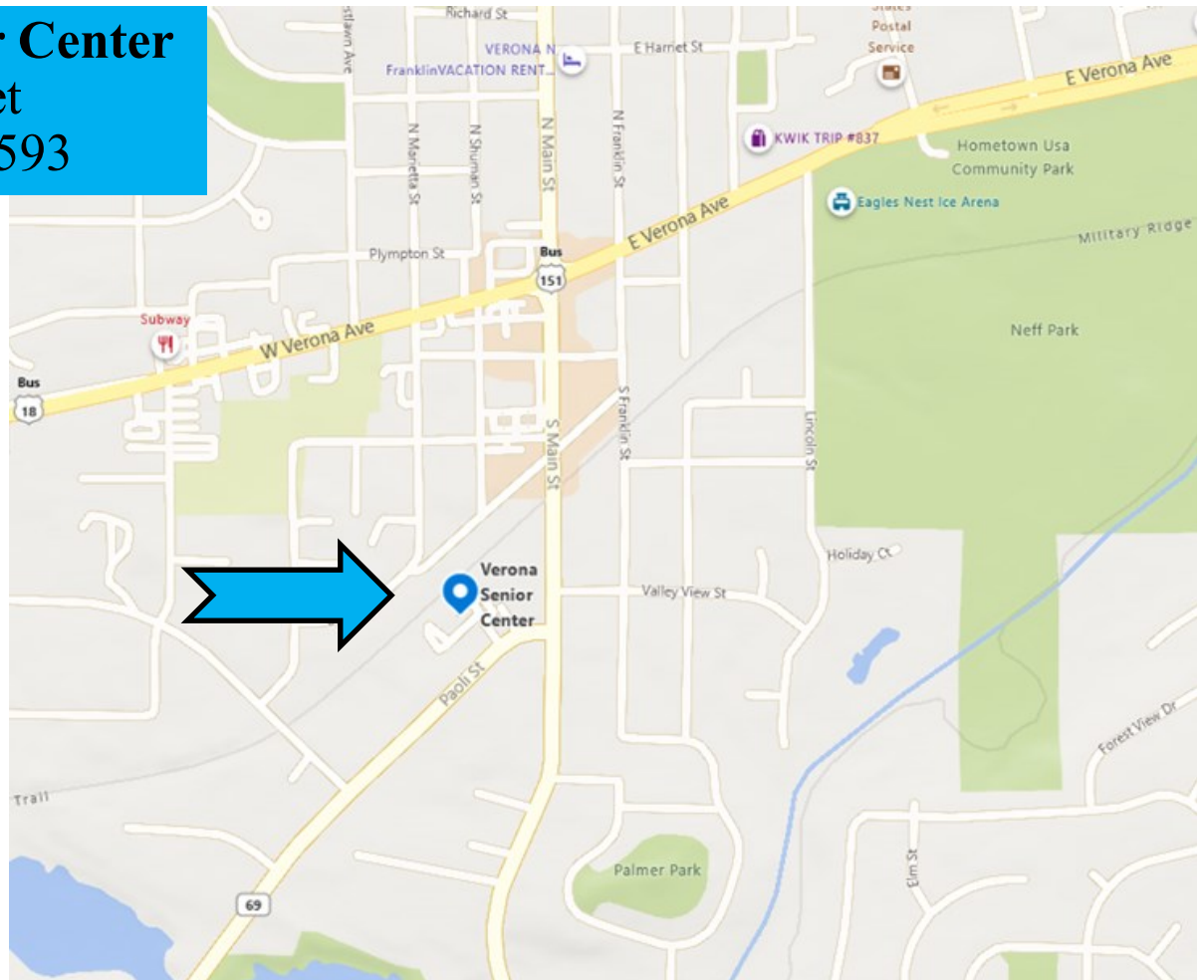



NMRA NEWS



July 14 – 19, 2025
www.nmra2025.org

**Big 2 day
National Train
Show!**

**NMRA National
Convention**

STATION No. VI

**2025
NMRA**

Novi, MI

CELEBRATING 90 YEARS

STATION No. VI NMRA National Convention

Barrie Hensel

Station No. VI publicity chairman

Hello NMRA members! The 2024 NMRA National Convention is complete and the 2025 National convention

– **STATION No. VI** –

is heading down the track at full steam ahead!

Registration is open and we already have over 100 registrations.

Go to

[**nmra2025.com**](http://nmra2025.com)

to see all of the event details and the registration page.



**Minutes SCWD Board Meeting
6:30 PM, 14 January 2025
via Zoom meeting**



The meeting of the South Central Wisconsin Division Board of Directors was called to order at 6:32 pm by Superintendent Art Dawson. Art Dawson, Bob McGeever, David Down, David Dingman, Phil Hottman and Steve Preston were present.

Minutes

Motion by McGeever, second by Hottmann to approve the minutes of the SCWD Board Meeting held on December 10th, 2024. Motion carried.

Paymaster Report

Bob McGeever presented the highlights of the December Paymaster Report. Motion by Hottmann, second by Preston, to approve the Paymaster Report as presented. Motion carried.

Committee Reports

Picnic – John Haverberg has contacted the caterer from the last picnic. Update next month.

Achievement Program - Nothing to report.

Advertising - Nothing to report.

Bad Order - Articles have to be submitted for the newsletter by January 17th.

Clinics – Phil Hottmann is presenting one of the clinics in February.

Contests - Model and Photography – Updates in Bad Order.

Modeling Project – Nothing to report.

Door Prizes – Nothing to report.

Layout Tours – John Krueger is scheduled for February. Craig Wright is scheduled for March. John Shaffer and Bob McGeever are possibilities for April 2025.

Membership - Steve Preston one new member has signed up. He reported some members in the 30/60 day windows for renewing their NMRA membership.

Spring Banquet - Nothing to report until after Rail School in January.

Publicity – Nothing to report.

Rail School - January 5, 2025 – Had approximately 40 guests at Rail School this year. Steve Preston reported signing up three new Youth Group members during Rail School.

Rail Show - The *57th Madison Model Railroad Show and Sale* will be held on February 15 - 16, 2025. Vendor table reservations are currently about budgeted amount. Show floor planning is underway.

Youth Group – Three new members joined during Rail School.

Website – Planning for transition to new web site host postponed until after Rail Show.

Old Business:

Nothing to report.

New Business:

Phil Hottmann asked if current BOD members would be running for re-election at the April meeting. Phil will be checking with SCWD members about filling the vacancy on the BOD.

Adjournment:

A motion was made by Preston, second by Down, to adjourn the meeting. Motion carried. The meeting was adjourned at 6:57 pm.

David Dingman - SCWD



MADISON HOBBY STOP

6622 Mineral Point Road, Madison, WI 53705

Ph: 608-829-3820 • Fax: 608-829-3852 • www.madisonhobbystop.com

Hours: Monday – Friday (10 am – 8 pm) and Saturday (10 am – 5 pm)

Model Railroading • Plastic Model Kits • Rockets & Accessories • Pine Car •
Paints • Tools & more!



**Now that Winter is finally here,
there is more time to keep working on the layout.**



For all the supplies you need, I have most in stock always or can order.

**Huge used collection of HO items just came in from a
longtime friend and customer, including brass steam, brass cabooses,
dcc locomotives, 200+ freight cars and kits, 100+ built up buildings,
people and vehicles.**

We are now closed on Sunday until late November.

Thank you for your continued support.



**Preorders are 25% off regular price except
Walthers Proto which is 20% off**

New/old consignment coming in weekly, stop in for best selection

**Remember, most model railroad items are 20% off
with a valid NMRA or other club id card**

Excludes discounted or sale items, magazines, and consignments

Gift Certificates Available

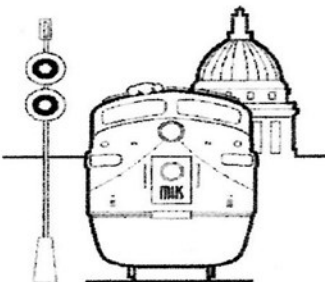

Madison Hobby Stop
Chris Roosli, Proprietor

The Hobby Depot

Brian Stackpole, owner



See us on the web at: www.hobbydepotmonroe.com



835-17th Street
Monroe, Wisconsin 53566

Phone: 608-325-5107

Call ahead to be sure we're open!

email: hobbydpo@tds.net

TRAINS & MORE

South Central Wisconsin Division of the National Model Railroad Association

Publishes eleven issues yearly of the

BAD ORDER

Official Mailing Address:
BAD ORDER
3940 Trempealeau Trail
Verona, WI 53593

Photos in the Bad Order, unless otherwise noted,
are by Kathy Clancy

Deadline for submissions: **14th of the month
prior to publication.** Email Bad
Order Editor at SCWDKATHY@AOL.com

Place your ad here!!!

Contact
Kathy Clancy
Bad Order Editor
SCWDKathy@aol.com



If you change your
email address

Don't forget to notify the NMRA and
Kathy Clancy
Bad Order Editor

Thank you!

Railroad Collectibles

Wanted to Purchase:

Annual Passes-Card size-Pre 1830
Annual Reports
Brochures-Railroad Brochures, Folders, Booklets
Calendars-Pre-1980 Railroad Issued
Depot Related Items: Telegraph-Telephone-Signs-
Ticket Dater Machines-W/Brass Die Insert
Diagram Books-Locomotive-Freight-Passenger
Dining Car China-Silverware-Holloware-Glassware
Especially With Railroad Name, Initials,
Logo
Engineering Data Books-Track Charts-Blue Prints
Great Lakes Car Ferry and Passenger Lines-
Passenger Service Memorabilia
Fred Harvey Restaurant Items-Dishes, Glass, Silver,
Paper and any Miscellaneous Items
Locomotive Builder Plates
Miscellaneous-Many more items not mentioned
Publications-RR Historical Societies-RR Employee
Magazines
Signs-Porcelain or Metal with Railroad Logo
Step Boxes-with RR Name/Logo
Timetables-Public and Employee Railroad Sched-
ules
Wax Sealers-From Railroads or Express Companies
Model Railroad Items: HO Gauge-Brass Equip-
ment O Gauge (2 Rail 1/4" scale), Brass
Equipment, Kits, Passenger and Freight

NOT BUYING:

No Model Railroad Magazines
No Insulators, Date Nails, Tokens, Post Cards,
Watches or Belt Buckles

RAILROAD RELICS
LARRY BUNCE
201 NORTH KERCH ST.
BROOKLYN, WI 53521
(608) 455-4233

EMAIL: rrrellmb@charter.net or
rrrellmb@gmail.com

****BUY**Shows-Ebay**SELL**

PLEASE PATRONIZE OUR AREA HOBBY STORES

The Hobby Depot – 835 17th Street – Monroe WI
Madison Hobby Stop – 6622 Mineral Point Rd (inside Clock Tower) – Madison WI *

* = Train Show Ticket advance sales

SCWD 2025-2026 Meeting Schedule

Regular Meeting

March 2, 2025
April 6, 2025
May 4, 2025 at Rockford

BOD

March 11, 2025
April 15, 2025
May 13, 2025

Youth Group

March 8, 2025
April 12, 2025
May 10, 2025

A Word about Constant Contact e-mail

Each Constant Contact e-mail includes links to update or unsubscribe your e-mail address. **Please do not use these links.** If you unsubscribe using the Constant Contact link, your e-mail address will be removed from the NMRA membership database, from the Midwest Region e-mail database and probably from your Division's records. If you get an e-mail that you don't want, just hit the delete key. Furthermore, if you use the update link, your change may not be timely posted to the NMRA membership database.

If you need to change your email address with the NMRA please follow these directions:

The direct way is to log on to the "Members" page of the NMRA website, choose the "View your NMRA membership" box on the right side of the screen, scroll down to the bottom of the page and select "Update". Enter the new email address in the appropriate box and click "Submit".