

## Research Article

### RFID Based Attendance System using IoT

B. Nandhakumar, K. Naveen kumar, M. Vijay, A. Sriram

*Department of Electronics and Communication Engineering, Arasu Engineering College,  
Kumbakonam – 612501. India.*

\*Corresponding author's e-mail: [contactsriramnow@gmail.com](mailto:contactsriramnow@gmail.com)

#### Abstract

In classrooms, time is wasted in roll calls as it is done manually. In this proposed system, authorized student is given an RFID tag. Thus, the data stored in this card is referred as the identification/attendance of the person. Once the student places the card in front of the RFID card reader, it reads the data and verifies it with the data stored in the microcontroller from 8051 family. If the data matches, then it displays a message on the LCD confirming the entry of that student else displays a message denying the attendance. The status of a student's attendance can be retrieved from this system by pressing the status button interfaced to the microcontroller. Hence, a lot of time is saved as all the students attendance is directly stored in the data base.

**Keywords:** Internet of Things; Radio frequency identification; Microcontroller; Attendance system.

#### Introduction

The concept "Internet of Things" (IoT) has recently attracted growing attention from both academia and industry. IoT is a scenario where devices (even animals or people) are provided with unique identifiers and the ability to automatically transmit data over a network without requiring human-to computer interaction [1]. IoT is a scenario where devices (even animals or people) are provided with unique identifiers and the ability to automatically transmit data over a network without requiring human-to computer interaction. RFID forms an essential block of IoT where RFID devices are wireless microchips used for tagging objects for automated identification [2].

Student attendance is an essential part of daily teaching. Traditionally, teacher bears the mission of calling the class names. Consequently, this consumes time, also does not have any flexibility in generating reports or statistics. To get rid of manual attendance process, represented by paper sheet signature, researchers have proposed many technologies that include barcode based attendance system, face recognition, and fingerprint identification. However, these systems suffer from some hindrances and difficulties [3]. The most common method of tracking student attendance system is to take a roll call or signing the

attendance sheet which is done manually. For a classroom of larger strength, both the methods are cumbersome. The roll call method is easily prone to fake attendance in a classroom of large size and it also takes a longer time to call the names of all the students [4]. The significant problems also arise when it comes to the transformation of the paper-based data to an electronic form to be used in student electronic records for calculating the total attendance at various levels (e.g. subject, study program, faculty or university) [5].

In addition to all the aforementioned disadvantages, the most common disadvantage is that all these methods need extra equipment. The proposed system has been developed to address these disadvantages. The main advantages of the proposed system are flexible usage, no equipment costs, no wasted time, and easy accessibility [6]. The classroom attendance system is based on face recognition technology, combined with RFID technology. It realized the identity confirmation of the students in the class effectively. Through the real-time test of the algorithm, it fully meets the requirements of the attendance time in the class, reduces the attendance cost of the classroom, and effectively solves the problem of signing and other issues [7]. For web-server platform, XAMPP software is used. XAMPP is the software that has

complete PHP, Apache, and MySQL web development environment. XAMPP software is a free and open source web-server for local development of web-based applications. SQL is a special-purpose programming language designed for managing data held in a relational database management system. The MySQL tool in XAMPP is PHPMyAdmin. To store the unique ID in the student card, MySQL is required. In MySQL, four tables have been created, that consists of staff table, student table, student attendance table and student marks [8].

### Proposed system

Figure 1 is the block diagram of our project RFID Based Attendance System using Arduino, RTC & LCD Display. Here Arduino UNO acts a central processor for controlling all other components as input/output unit. We have used 5 volt power supply to power all the components used in this project. RFID Reader module is interfaced with Arduino to read the data from RFID Card/tag. Real Time Clock (RTC) Module DS3231 is used to display the current time and date on the LCD as well as arriving and leaving time of the users. LCD displays every output like current date & time, information of users, no of staffs present or absent and menu options from 1 to 4. Red & Green LED is used for the indication of arriving and leaving. Similarly buzzer produces sound whenever the interrupt is detected. The very important part of this block diagram is EEPROM part. EEPROM stands for Electrically Erasable Programmable Read Only Memory. It stores the data whenever the users swap the card over RFID reader.

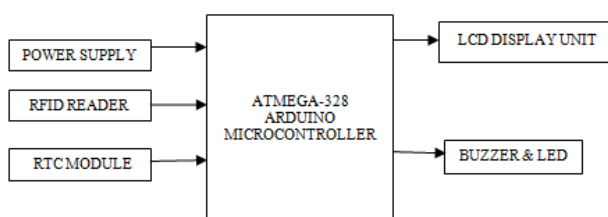

Figure 1. Input and output interface of the Arduino system

### Arduino Uno

The Arduino Uno is open source microcontroller board based on the microchip ATmega328P microcontroller and developed by Arduino. The board is equipped with sets of digital and analog input/output (I/O) pins that may be interfaced to various expansion boards (shields) and other

circuits. The board has 14 digital I/O pins (six capable of PWM output), 6 analog I/O pins, and is programmable with the Arduino IDE (Integrated Development Environment), via a type B USB cable. It can be powered by the USB cable or by an external 9-volt battery, though it accepts voltages between 7 and 20 volts. It is also similar to the Arduino Nano and Leonardo. The hardware reference design is distributed under a Creative Commons website. Attribution Share Alike 2.5 license AM.

### EM-18 RFIR reader module

The EM-18 RFID Reader module operating at 125kHz is an inexpensive solution for your RFID based application. The Reader module comes with an on-chip antenna and can be powered up with a 5V power supply. Power-up the module and connect the transmit pin of the module to receive pin of your microcontroller. Show your card within the reading distance and the card number is thrown at the output. Optionally the module can be configured for also a weight and output.

### RTC module (DS3231 or DS1307)

Real time clock is used to keep record off time and to display time. It is used in many digital electronics devices like computers, electronics watches, date loggers and situation where you need to keep track of time. RTC has a CMOS battery. Using DS3231 IC as the main component, several manufacturers developed DS3231 RTC Modules with all the necessary components. Almost all the modules available today consist of an additional IC, 24C32N (or something similar). This secondary IC is an EEPROM IC of 32Kb size. Since both RTC and EEPROM ICs are interfaced through I2C Protocol, you won't need any extra pins as both these I2C Devices can act as slaves while a microcontroller acts as a master. Since RTC is all about maintaining time irrespective of the power supply, you can connect a 3V CR2032 Lithium Battery to the RTC IC to keep the clock ticking. In the DS3231 Module, there is a provision for you to connect a battery using the battery holder provided on the back.

### PIN of DS3231 RTC module

As mentioned earlier, DS3231 IC and 24C32 EEPROM IC are the main components on a typical DS3231 RTC Module board. Apart from that, there are a few other components like

Power ON LED, few resistors, capacitors, a battery holder and pins for connecting with

microcontroller. Figure 2 shows the components and pins on the DS3231 RTC Module.

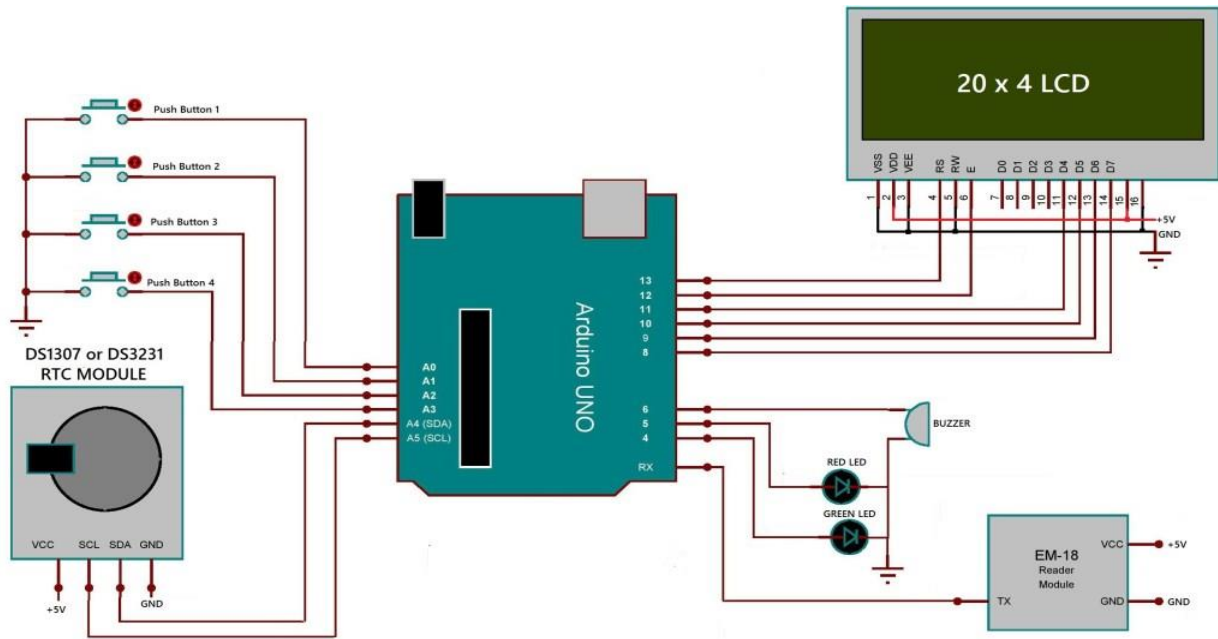

Figure 2. Circuit connection of the project

**Flow chart functionalits**

Flow chart of the reader and receiver module of the Proposed framework is shown in figure 3.

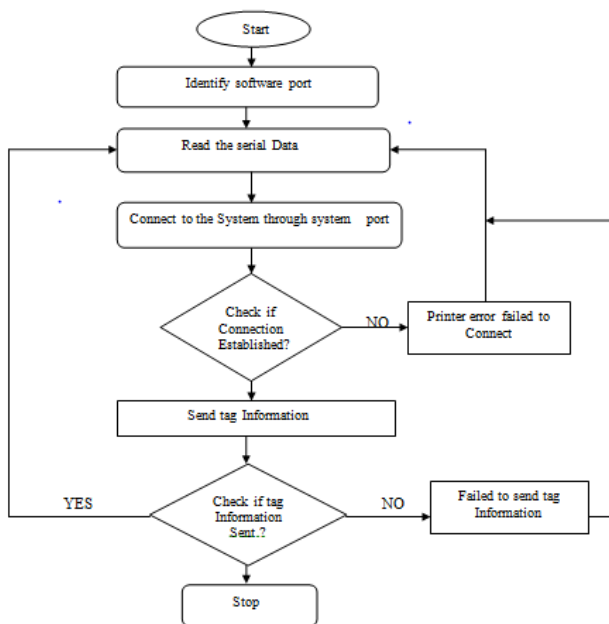

Figure 3. Flow chart of the reader and receiver module

**Proposed framework of the project**

The front end of the software is developed using the Tinder Module in Python. The backend is developed using MySQLite3 and open source cloud API. The proposed framework will include aspects of engineering from data collection and aggregation, analysis, data processing, the

necessary actions would be performed on the database, and the result is displayed on the screen. When the attendance button is pressed, it takes the user to the Attendance Page. We have used threading programming in Python to enhance the execution performance of the software.

**Results and discussions**

In this section, we identify some limitations and discuss future plans for our system. For this prototype, due to laboratory limitations, we invited just five volunteers to participate in our experiments and evaluated the system performance on this basis. However, when the number of people is increased, the detection accuracy may be affected. This is because the more people there are; the more likely they are to have similar body features, which will require that we obtain more refined features. In addition, real-time capability may also be a key consideration for further enhancing the robustness of our system. The figure 4 shows the experimental working of the circuit and also its gives the real time output of our project.

**Conclusions**

Our goal is to develop a secure, portable and ready to deploy RFID-based attendance. The system provides a practical and efficient solution for monitoring student attendance on a large

scale. The proposed attendance monitoring system uses the concept of IoT to log and fetch data on the server/cloud and make it available for the user anytime and anywhere. For future work, we would also like to give access to students about their attendance, so they can log in and check their attendance remotely. We would integrate the entire system with a mobile phone application so that all functionality is on the mobile itself. Also, we would like to integrate this system with Canvas or Blackboard using XML interface.

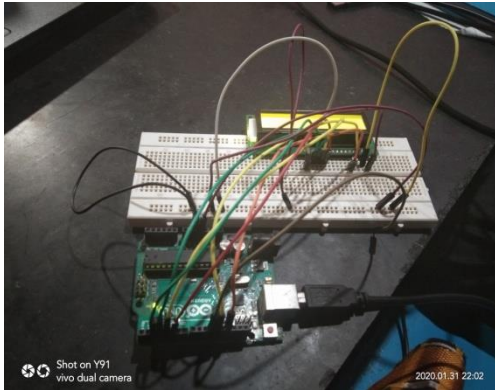

Figure 4. Experimental results

### Conflict of interest

Authors declared no conflict of interests.

### References

- [1] Sri Madhu BM, Kavya K, Devansh. IoT based automatic attendance management system, IEEE International Conference on Current Trends in Computer, Electrical, Electronics and Communication, September 2017.  
DOI: 10.1109/CTCEEC.2017.8455099
- [2] Qianwen M, Fu X, Haiping H, Lijuan S, Ruchan W. Smart Attitude Algorithm with Parrite RFID Tags. IEEE Conference 2018.
- [3] Hassan S, Ertan Z, Ghassan AH. New anti-collision protocol for RFID – Based Student Attendance system. 2nd International Symposium on Multidisciplinary Studies and Innovative Technologies (ISMSIT). October 2018.  
DOI: 10.1109/ISMSIT.2018.8567278
- [4] Faisal RB, Khoirun N, Roudhotul AS et al. Implementation of RFID Attendance System With Face Detection Using Validation Viola-Jones and Local Binary Pattern Histogram Method. International Symposium on Electronics and Smart Devices (ISESD). October 2019.
- [5] Nguyen HK, Chew MT. RFID – Based Attendance management System, 2nd Workshop on Recent Trends in Telecommunications Research (RTTR) Palmerston North, New Zealand. 2017.
- [6] Sri vignesh PSS, Bhaskar M. RFID and Pose Invariant Face Verification Based Automated Classroom Attendance System. International Conference on Microelectronics, Computing and Communications (MicroCom). January 2016.
- [7] Wenxian Z, Qinglin M, Ran L. Design of Intelligent Classroom Attendance System Based on Face Recognition. IEEE 3rd Information Technology, Networking, Electronic and Automation Control Conference (ITNEC). March 2019.
- [8] Xiao F, Wang Z, Ye N, Wang R, Li XY. One More Tag Enables Fine – Grained RFID Localization and Tracking. IEEE/ACM Transactions on Networking 2019;26:161-78.

\*\*\*\*\*