

OMP40 probe system

OMP40 probe system with 360° optical transmission.

The probe can be switched on and transmits through 360°, for ease of operation on vertical and horizontal CNC machining centres.

Each system component is fully described in its own separate data sheet - please see parts list on back page.

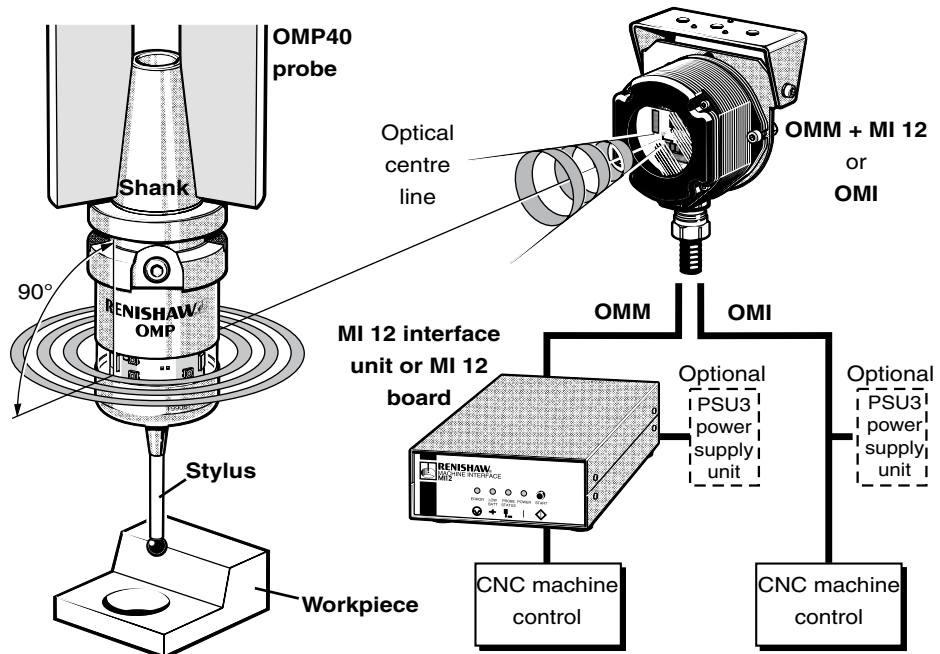

System components

- **OMP40 probe**
The OMP40 is a compact 3D touch-trigger inspection probe ($\pm X$, $\pm Y$, $+Z$ sense directions) with optical transmission, used for workpiece set-up and inspection on small CNC machining centres.
- **OMM (optical machine module)**
Transmits CNC messages to the probe and receives data signals for transmission to the MI 12 interface.
- **MI 12 interface unit**
Processes signals between the OMM and the CNC machine control.
- **OMI (optical machine interface)**
An alternative to the OMM + MI 12 interface, combining the functions of both OMM and MI 12 in one unit.
- **PSU3 power supply unit for MI 12 or OMI**
Used when 24 V supply is not available from the machine.
- **Software for probe routines**
The OMP40 is suitable for use with Renishaw single and double touch probing cycles.

System features

- **Signal transmission**
The OMP40 transmits through a full 360° at an angle of 90° to the spindle axis, with a range of over 3 m.
- **Battery life**
A standard battery life of 140 hours continuous use, or the equivalent of over 115 days at 5 % usage is achievable. Where low power mode is selected, battery life is increased to 210 hours and 175 days respectively.
- **Probe repeatability**
Repeatability, 1.0 μm (40 μin) is certified at 480 mm/min (1.57 ft/min) with 50 mm stylus.
- **Probe switch-on**
Probe switch-on is selectable between M code and auto start.
- **Probe, OMM and OMI sealing**
Sealed to IPX8 and designed for the machine tool environment.

Performance envelope - OMP40

The OMP40 has a 360° transmission envelope over the ranges shown below.

The probe system should be positioned so that the optimum range can be achieved over the full travel of the machine axis.

The positions of the OMP and OMM/OMI may deviate from the optical centre line, provided they lie within each other's field of view.

Natural reflective surfaces within the machine may affect the signal transmission range.

Coolant residue, accumulating on the OMP and OMM/OMI windows, will have a detrimental effect on transmission performance. Wipe clean as often as is necessary to maintain unrestricted transmission.

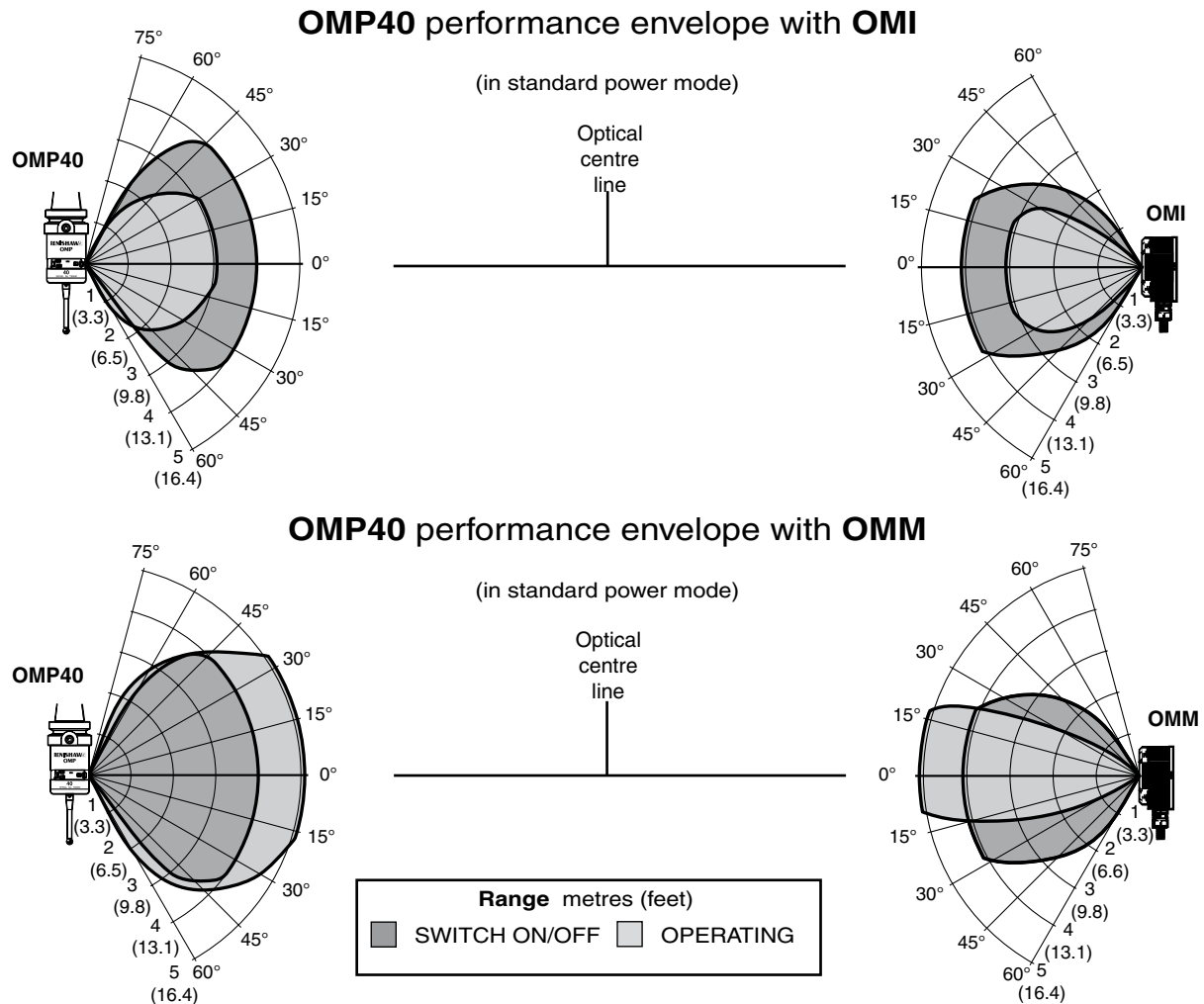

OMP40 dimensions

mm (in)

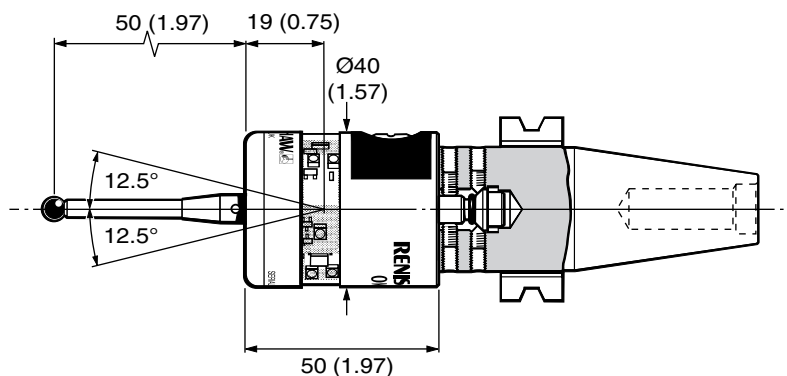

System operation

Prior to probe operation, it is imperative that the program selected to ‘drive’ the probe has been verified. Incorrect programming could result in damage to the machine, workpiece and probe system.

The OMP40 probe operates in one of three modes:

- 1. Stand-by mode** - The OMP40 uses a small current, while passively waiting for a switch-on signal to be received via the probe’s receiving diodes.
- 2. Operating mode** - Activated by one of the methods described below. Signals are only transmitted by the probe in this mode and the probe is now ready for use.
- 3. Programming mode** - The Trigger Logic™ programming method allows a number of probe set-up options to be programmed, by triggering the probe when the batteries are inserted. The programmable switch-off options are described below.

Probe switch on

The probe is switched on by one of the following options.

- 1. Manual start**
(system with OMM + MI 12 only)
Initiated by pressing the MI 12 manual start button.
- 2. Machine start - factory set to this option**
(system with OMM + MI 12 or system with OMI)
Initiated by an M code start signal generated by the program.
- 3. Auto start**
(system with OMM + MI 12 or system with OMI)
Initiated by auto start signal sent every second.





Probe switch off

The probe is switched off by one of the following options.

- 1. Optical on / optical off - factory set to this option**
A second start signal is generated by a software M code, which switches the probe off.
(minimum ON time 1 second).
- 2. Optical on / timer out - programmable option**
A timer automatically returns the probe to stand-by if the probe has not been triggered for 12 seconds or 33 seconds or 134 seconds
Time out durations are user programmable.

Probe status LED

The probe status LED gives a visual indication of the probe state (triggered or seated). It also indicates when the battery has become unusable.

PROBE STATUS LED		
LED Colour	Probe status	Graphic hint
Unit	Stand-by mode	
Flashing green	Probe seated in operating mode	
Flashing red	Probe triggered in operating mode	
Flashing green and blue	Probe seated in operating mode - low battery	
Flashing red and blue	Probe triggered in operating mode - low battery	
Constant red	Battery dead	

Battery dead - at this stage probe status is forced open and the probe cycle will stop.

Enhanced trigger circuit

Probes subjected to high levels of vibration or shock loads, may suffer from false readings. The enhanced trigger circuit improves the probe’s resistance to these effects.

When the circuit is enabled, a constant nominal 10 millisecond delay is introduced to the probe output.

It may be necessary to revise the probe program software to allow for the increased stylus overtravel during the extended time delay.

Factory set OFF.

Enhanced start circuit

Probes subjected to particular forms of light interference may activate unexpectedly. The enhanced start filter improves the probe’s resistance to this interference.

When the filter is enabled, an additional two second delay is introduced to the probe activation time.

It may be necessary to revise the probe’s program software to allow for the increased activation time.

Factory set OFF.

Low power (Battery save) mode

Where the separation between probe and OMM/OMI is small, the low power mode may be used. In this mode the optical transmission range will be reduced by 30% and battery life will be extended. See battery life.

OMP40 probe specification

Primary application	Inspection probe for machining centres
Sense directions	5 way $\pm X \pm Y + Z$
Trigger force using 50 mm (1.97 in) stylus low force direction	XY 0.5 N / 50 gf (1.76 ozf) Z 5.85 N / 585 gf (20.62 ozf)
Trigger force using 50 mm (1.97 in) stylus high force direction	XY 0.9 N / 90 gf (3.17 ozf) Z 5.85 N / 585 gf (20.62 ozf)
Overtravel	XY 12.5° Z 6 mm (0.24 in)
Sealing	IPX8 (BS 5490, IEC 529) 1 atmosphere
Repeatability	1.0 μm (0.00004 in) is valid for maximum 2σ value in any direction test velocity of 480 mm/min (1.57 ft/min) at stylus tip, using stylus 50 mm (1.97 in) long.

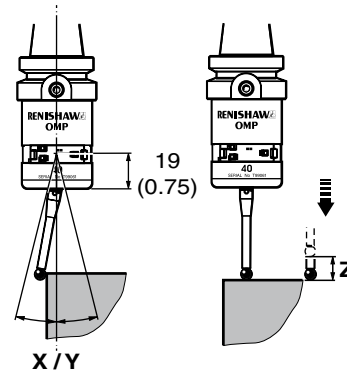

STYLUS OVERTRAVEL LIMITS		
Stylus length mm (in)	$\pm X / \pm Y$ mm (in)	Z mm (in)
50 (1.97)	12 (0.47)	6 (0.24)
100 (3.94)	22 (0.87)	6 (0.24)

Battery life

Stand-by life		5% usage - 72 minutes/day		Continuous use	
Typical (days)		Typical (days)		Typical (hours)	
Standard power mode	Low power mode	Standard power mode	Low power mode	Standard power mode	Low power mode
1900	1900	115	175	140	210

Typical battery reserve life

Using the standard Lithium battery at 5 % usage, the probe will typically continue to operate for approximately 2 weeks after a low battery warning is first indicated.

Parts list - please quote the part number when ordering equipment

Type	Part no.	Description
OMP40/OMM/MI 12	A-2033-1126	OMP40 probe with batteries, stylus, OMM, OMM mounting bracket, MI 12 interface unit and tool kit.
OMP40/OMI	A-2115-0032	OMP40 probe with batteries, stylus, OMI, OMI mounting bracket and tool kit.
OMP40	A-4071-0001	OMP40 probe with batteries and tool kit.
Battery	P-BT03-0007	½AA batteries (pack of 2).
Battery cassette	A-4071-1166	Probe battery cassette assembly.
Cassette seal	A-4038-0301	Battery housing seal.
Stylus	A-5000-3709	PS3-1C ceramic stylus 50 mm (1.97 in) long with Ø6 mm ball.
TK62	A-4071-0060	Probe tool kit comprising: Ø1.98 mm stylus tool, 2.0 mm AF hexagon key, shank grub screws (x6).
Mtg brkt	A-2033-0830	OMM/OMI mounting bracket with fixing screws, washers and nuts.
Shank adaptor assembly	A-4071-0031	Adaptor assembly for mounting to MP10, MP12, MP700 shank.
Pull-up cone assembly	A-4071-0094	Replacement pull-up cone for attachment to OMP40 shanks.
Styli	-	See brochure H-1000-3200 styli and accessories.
Shank	-	See data sheet H-2000-2011 taper shanks.
OMM	-	See data sheet H-2000-2275 optical module machine.
MI 12	-	See data sheet H-2000-2195 MI 12 interface unit.
OMI	-	See data sheet H-2000-2285 optical machine interface (alternative to OMM + MI 12).
PSU3	-	See data sheet H-2000-2200 PSU3 power supply unit (optional).
Software	-	See data sheet H-2000-2289 probe software for machine tools.