

Pump Data

- SH 7.5HP 7-11/16 Imp, 1 Stage Centrifugal Pump
- 316L SS Corrosion Resistance Construction
- Built-In Overload / Auto-Reset Provided
- 35 amp 230V Single Phase UL Motor
- 1-1/2 F NPT Suction

Pump Flow

(not for certification use)

GPM	0	40	60	80	100	150
PSI	94	88	82	73	67	39

Components

A - 1-1/2 F NPT Galvanized Riser

B - Supervised Control Valve

C - Water Pressure Gauge

D - D Panel Control Box

E - 40 60 Pressure Switch

F - SH7.5 HP UL Motor with Pump

G- Elevated on Steel Frame

*Wiring in Liquid Tight Conduit (not shown)

Check Box for Optional Equipment

- H -Flow Switch (+7 H)
- I-Bypass Line with Backflow Preventer (+4W)
- J- Butterball Valve

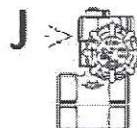
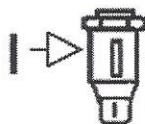
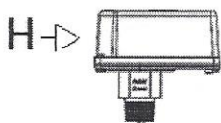

Model P-SH752-P

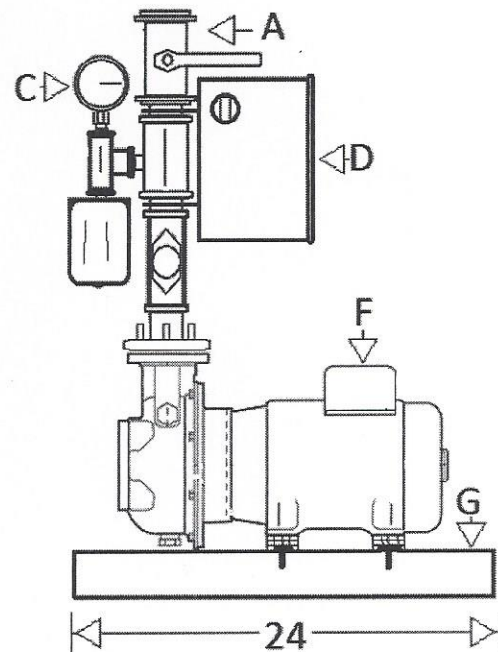
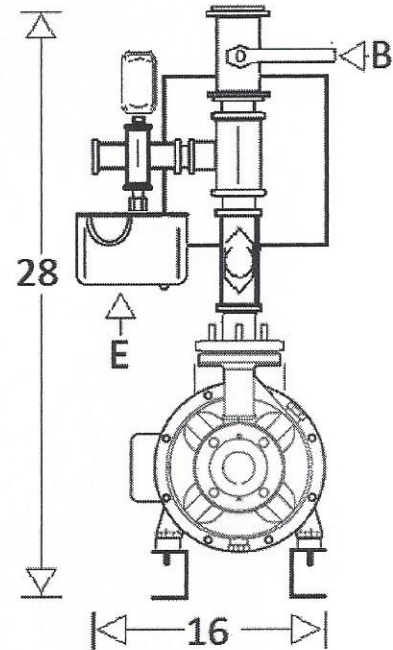

*Note: all measurement in inches