

THE GREAT INTERNATIONAL PAPER AIRPLANE BOOK

By
JERRY MANDER
GEORGE DIPPEL AND
HOWARD GOSSAGE

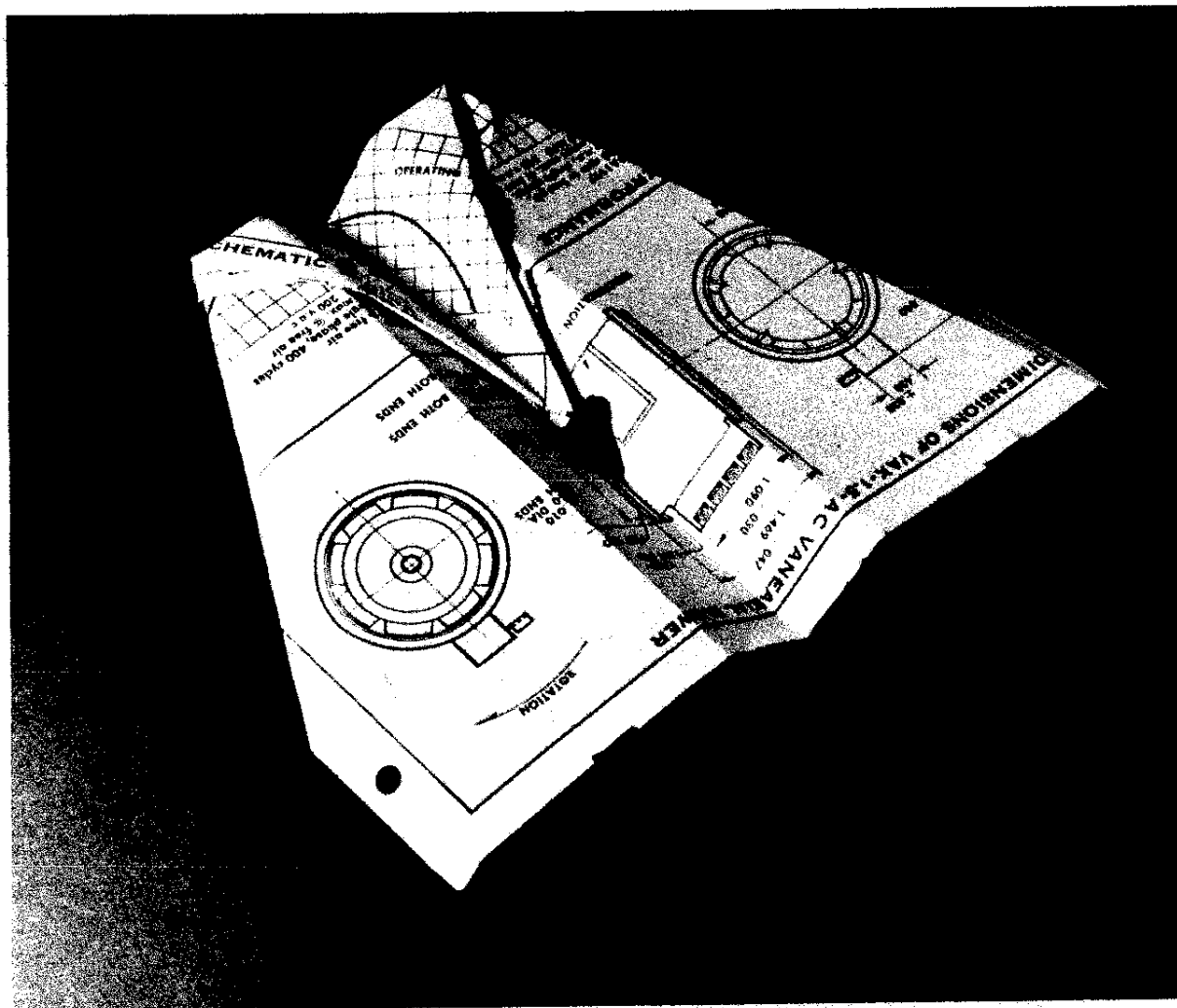

THE OFFICIAL FLY-THEM-YOURSELF BOOK OF PAPER AIRPLANES—WITH TECHNICAL DATA, DISTANCE AND TIME-ALOFT RECORDS, PHOTOGRAPHS AND COMMENTARIES—FROM THE FIRST INTERNATIONAL PAPER AIRPLANE COMPETITION



***WINNER: DURATION ALOFT/NONPROFESSIONAL**

Jerry A. Brinkman

Dayton, Ohio

(Assistant sales manager, Globe Industries)

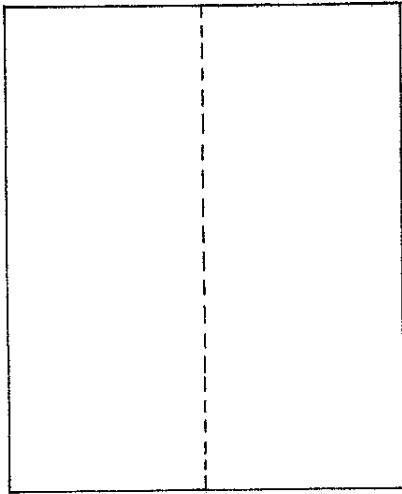

1. Fold 8" x 10 1/4" sheet on center line and open again

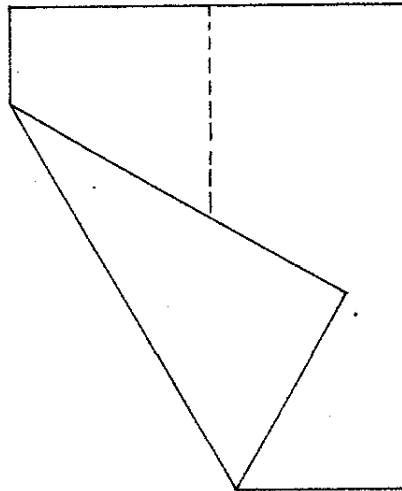

2. Fold corner forward as shown

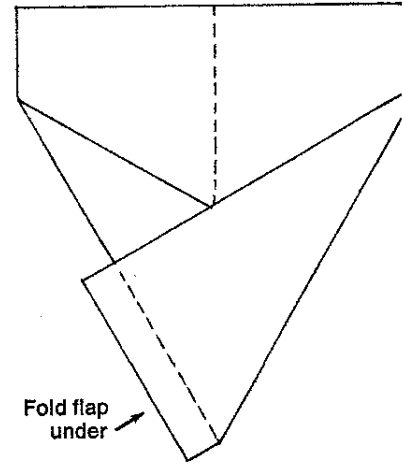

3. Do same to other side

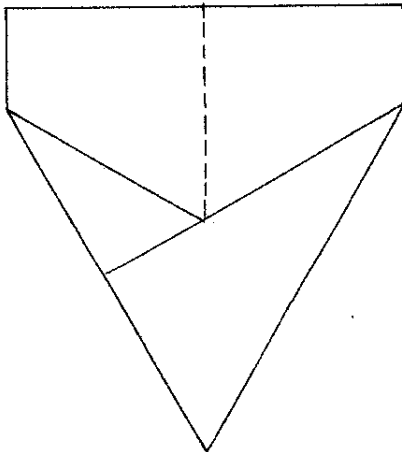

3. Bottom view

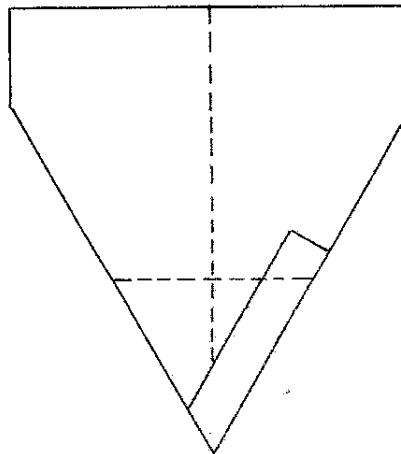

4. Turn plane over

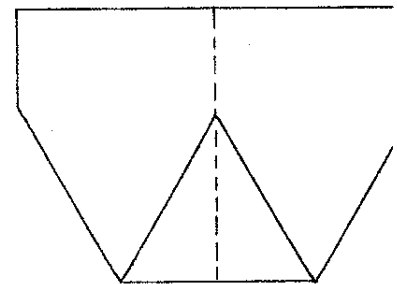

5. And fold nose forward at dotted line

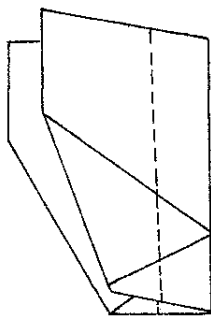

6. Fold on center line

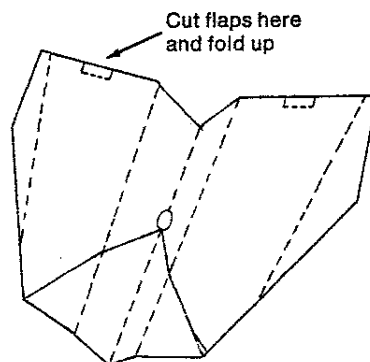

7. And on dotted lines

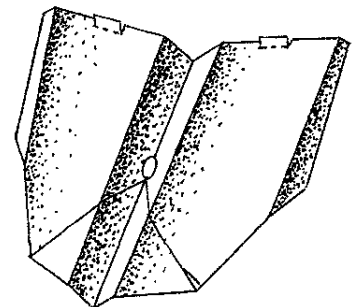

8. And shape as shown —cut finger hole as indicated

Cut

Cut

Cut

Cut

Cut this section out

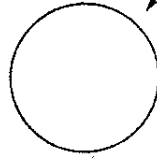

Tuck flap under

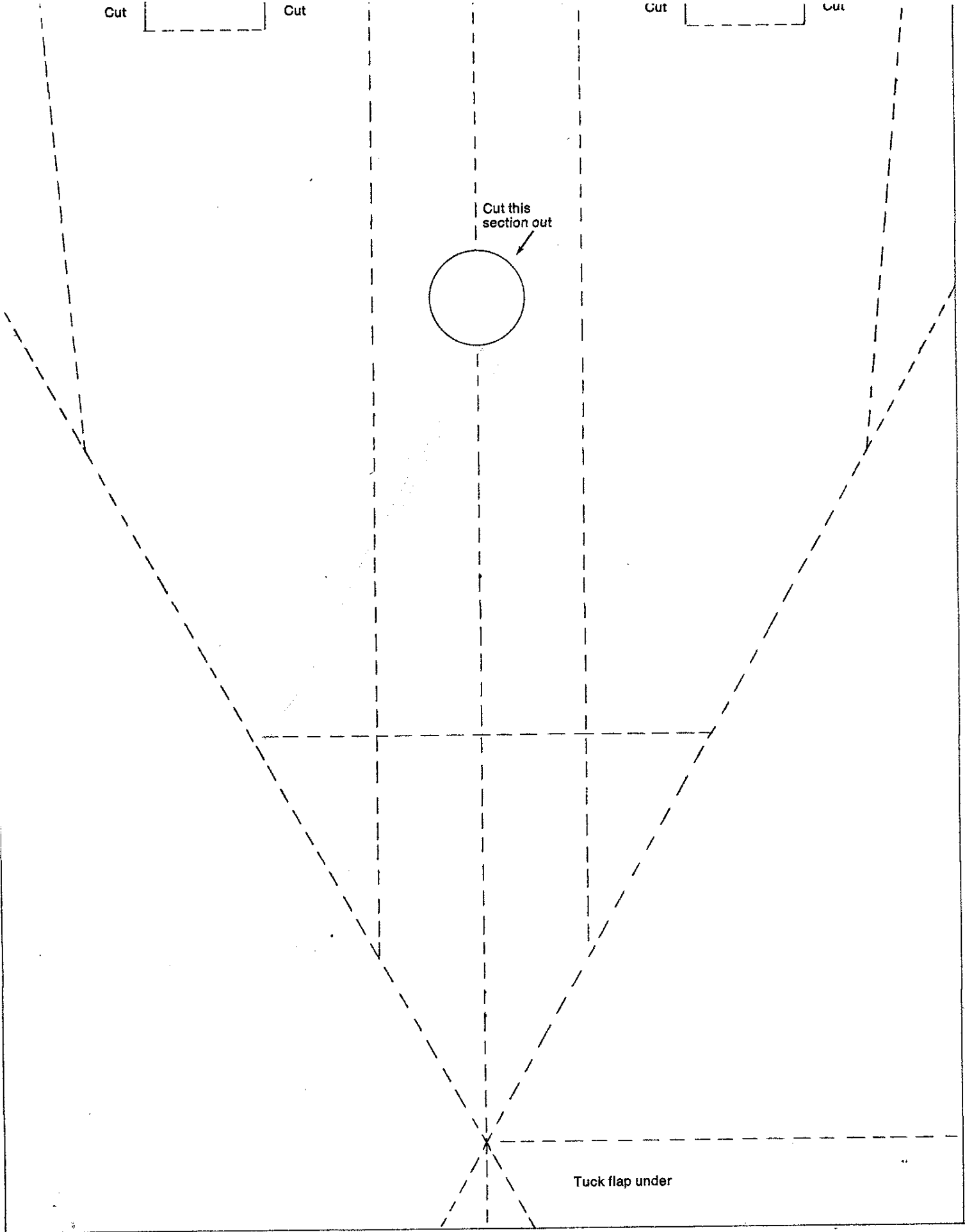

1978
TIME OF FLIGHT
DURATION FLYER #
7/sec

F. J. HOOVEN
410 JUNDINGDALE
BLOOMFIELD HILLS
MICH

***WINNER: DURATION ALOFT/PROFESSIONAL**

Frederick J. Hooven

Bloomfield Hills, Michigan

(Subscriber and special consultant to
general manager, Ford Div., Ford Motor Co.)

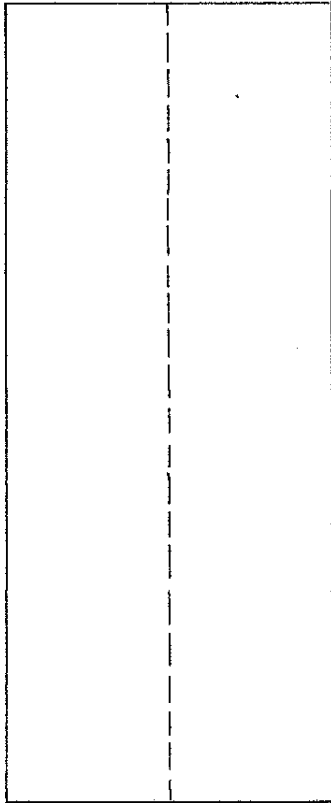

1. Fold in half and open again

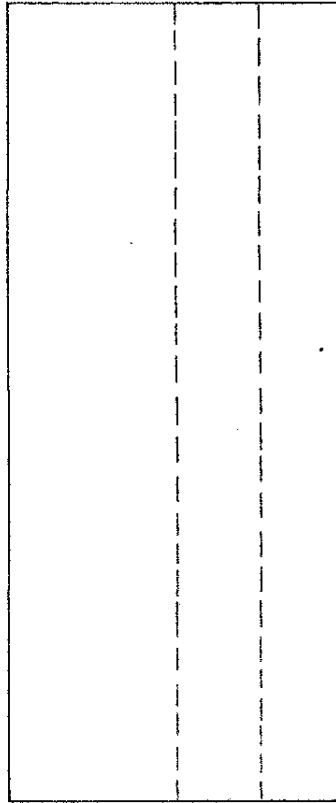

2. Fold one side in half

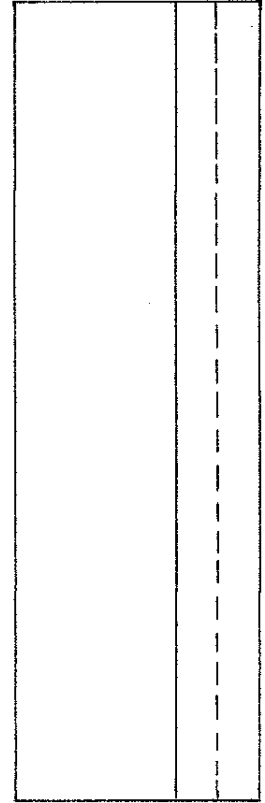

3. Fold same side in half again

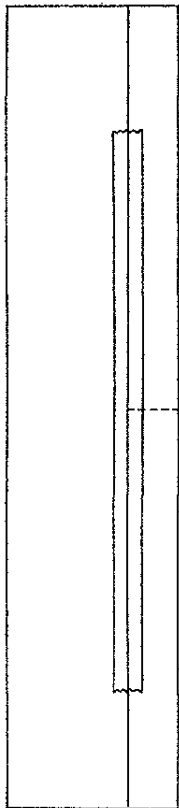

4. Fold over again; Tape

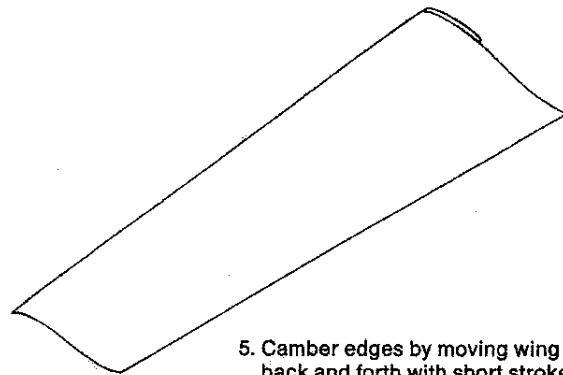

5. Camber edges by moving wing back and forth with short stroke over table edge

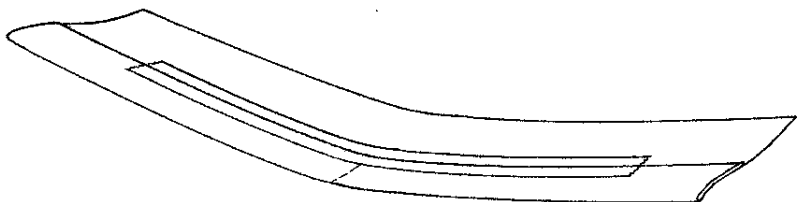

6. Crease folded section at center point. Hold between thumb and forefinger and launch with gentle horizontal motion.

