

# EF Therma-Fuser™

## Interoperable Square VAV Diffuser



Therma-Fuser™ Systems

Models: **EF-B**  
**EF-L**

Interoperable with BACnet™  
Interoperable with LonTalk®

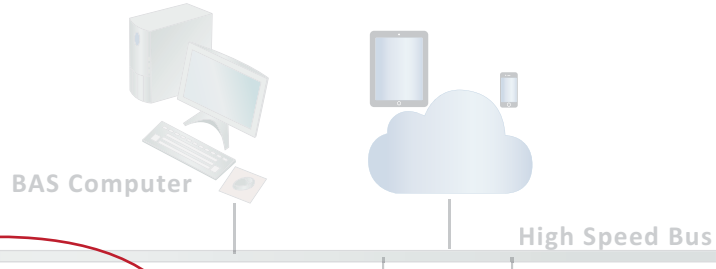

EF Interoperable VAV Diffuser

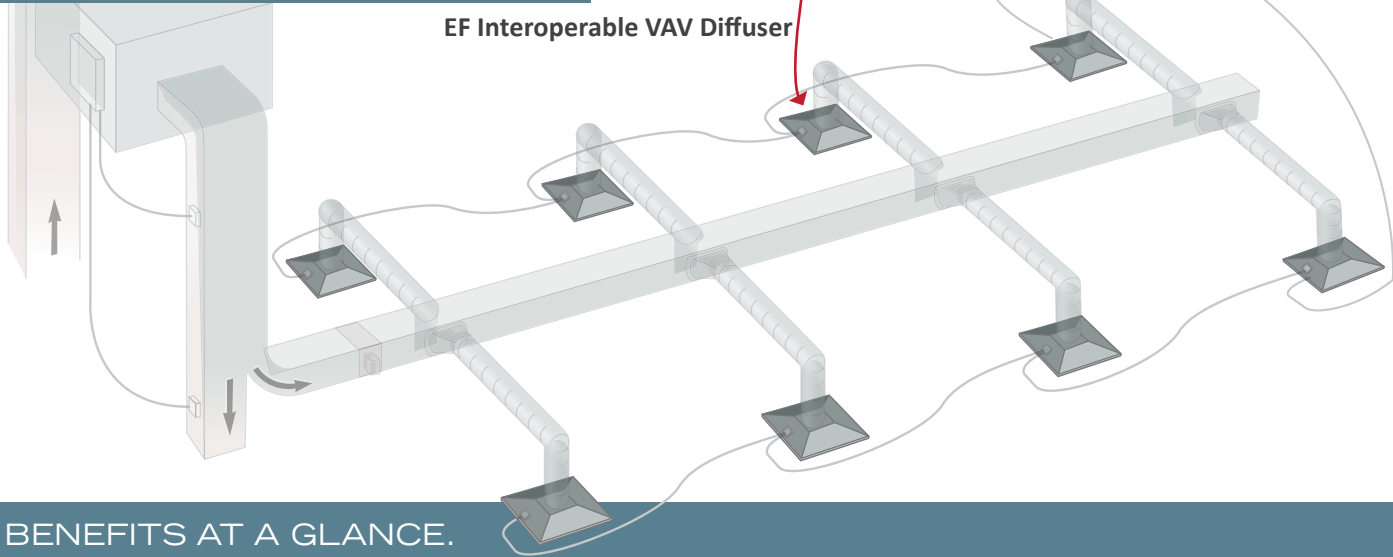

EF: Product Overview  
FORM 091.101 Rev 1401

### BENEFITS AT A GLANCE.

#### SPECIFICALLY DESIGNED FOR INTEROPERABILITY

The EF provides more information about what's happening in the space than any other VAV terminal because it monitors load, supply air temperature and flow at each diffuser. Native BACnet™ BTL® Listed or LonMark® compliance ensures that the EF will exchange data with products from other vendors on any LonWorks® or BACnet™ DDC building control network. Interoperability with other control networks is easy using gateways by other manufacturers.

#### Features

+ Comfort - Individual temperature control	✓
+ Comfort - Superior air distribution	✓
+ Energy - Energy saving system	✓
+ Sustainability - Adaptable system	✓
+ BAS room air temperature output to BAS	✓
+ BAS room temperature setpoints adjustable by BAS	✓
+ BAS diffuser supply air temperature output to BAS	✓
+ BAS diffuser supply air volume output to BAS	✓



BTL is a registered trademark of BTL. BTL is not affiliated with or endorsed by BACnet or LonMark. BTL is not affiliated with or endorsed by BACnet or LonMark. BTL is not affiliated with or endorsed by BACnet or LonMark. BTL is not affiliated with or endorsed by BACnet or LonMark.



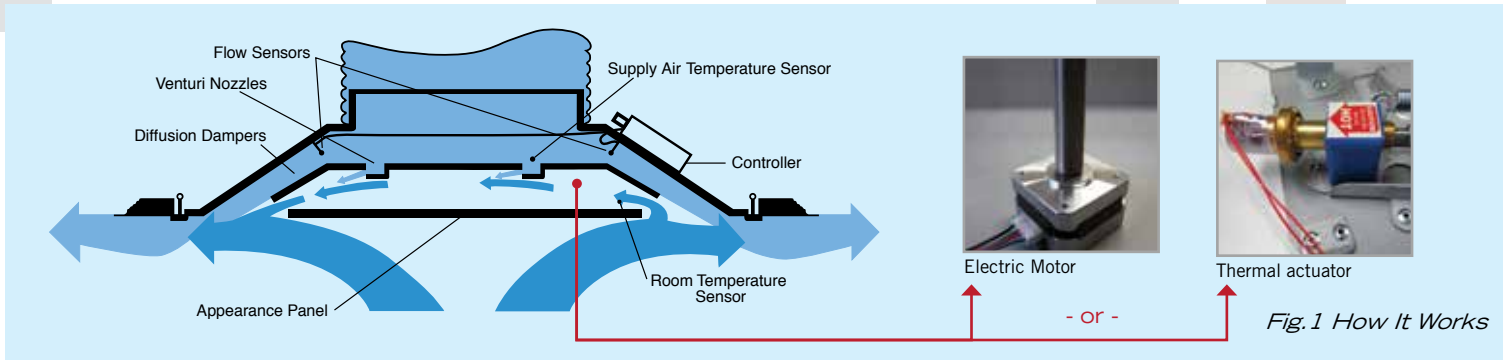

### HOW IT WORKS

Model EF Therma-Fuser diffusers are nominal 24" (600mm) square ceiling diffusers with built in DDC controller, temperature sensors, flow sensors and VAV damper. Four damper blades open and close to meter air flow (hot or cold) into the room in response to room temperature. The dampers are modulated by a choice of either a thermal actuator or an electric motor.

**Thermal actuators**, used for reliability and low maintenance, have a piston in a cylinder wrapped with a resistance heater. The cylinder is filled with petroleum wax which, when heated by the resistance heater, expands to push out the piston. When heat is stopped the wax rapidly cools and contracts and the piston retracts. The thermal actuator piston is precisely positioned with a variable DC signal to the resistance heater from the DDC controller.

**Electric motors** deliver a deliberate response for control of room temperature and, when required, a quick response to commands. The electric motor directly drives a threaded shaft connected with a linkage to the damper eliminating a failure prone gear box. The electric motor has been rigorously tested and will provide many years of reliable service.

The controller uses an 'expert system' control similar to having an "expert" sitting there making the adjustments. Unlike PID control, 'expert system' control does not require field tuning. Every 10 seconds it determines if the flow should be adjusted and the amount of any adjustment based on temperature relationships and both the rate and direction of change of flow.

### ROOM AIR SENSING

As with all diffusers, air circulates around the room in a circular motion. Secondary air rises under the diffuser, passes beneath the appearance panel and entrains with the primary air at the outside edge of the diffuser (See Fig. 1). This secondary air best represents average room temperature.

To monitor average room temperature, a continuous sample of secondary air is drawn around the appearance panel past the room temperature sensor. This is accomplished by feeding primary air through four Venturi nozzles. Primary air blowing through the nozzles creates just enough vacuum to draw some secondary air around the appearance panel, over the temperature sensor and out the other side. A properly applied EF will hold the room average within 1.5°F/0.9°C of the temperature selected.

### COOLING & HEATING MODES

In the cooling mode, the damper blades open on a rise in room temperature. In the heating mode the operation is reversed with the damper blades closing on a rise in room temperature. Determination of cooling/heating mode is made automatically by comparing supply air temperature to room temperature and set point. The diffuser is in the heating mode if the supply air temperature is warmer than **both** the room temperature and set point. The diffuser is in the cooling mode if the supply air temperature is cooler than **either** the room temperature or set point. The automatic selection of the heating/cooling mode can be overridden through the BAS.

### FLOW MEASUREMENT

The radius of the inlet elbow or direction of the supply air duct will bias the air flow out of a diffuser. To minimize any inlet effect, four flow sensors are positioned one to each side of the diffuser and averaged to provide an accurate measurement of air flow out of each EF. Heated thermistor flow sensors are used to provide accurate and maintenance free measurements.

### STANDARD OPEN COMMUNICATION PROTOCOLS

The EF is available with either BACnet™ or LonTalk® standard open communication protocol to make interoperability easier and simplify integration with building automation systems.

#### BACnet™

Native BACnet™ to ANSI/ASHRAE Standard 135.  
BTL® Tested and Listed.  
BACnet™ MS/TP three wire daisy chain network connection.

#### LonTalk®

LonMark® 3.2 Certification.  
LonMark® Functional Profile ID:8010 conformance.  
Free Topology FTT-10 two wire daisy chain, star or bus network connection.

### CONFIGURABLE VARIABLES / OBJECTS

- Measurements
  - Room Temperature

### DIMENSIONS

Inlet Designation	OD	
	Inches ± 1/16	mm ± 3
6	5 15/16	150
8	7 15/16	200
10	9 15/16	250
12	11 15/16	300

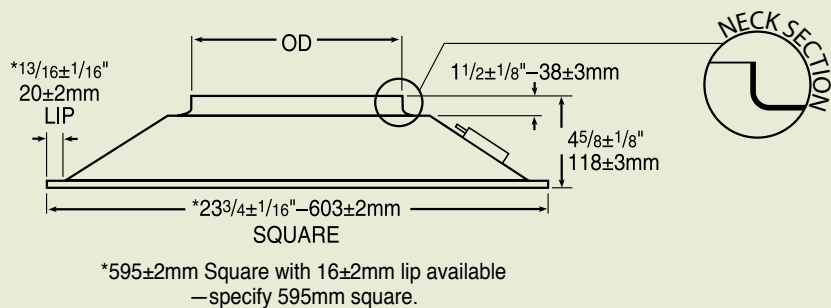

PERFORMANCE GUIDE in I-P UNITS

Inlet Designation	Inlet Static Pressure in. wg	Maximum Flow CFM	Maximum Flow		25% Maximum Flow	
			Throw - Feet* @ V <sub>t</sub> =50/100/150FPM	†NC	Throw* - Feet @ V <sub>t</sub> =50/100/150FPM	†NC
6"	.05	100	6/4/3	<15	3/2/1	<15
	.10	140	8/5/4	20	4/3/2	17
	•.11	147	8/5/4	21	4/3/2	18
	.15	175	9/6/5	26	5/4/3	21
	.20	200	9/7/6	31	6/5/3	24
	.25	220	10/8/7	34	7/6/4	27
8"	.05	160	8/6/4	<15	5/3/2	<15
	.10	225	10/7/5	20	6/4/3	16
	•.13	255	11/8/6	23	7/5/3	19
	.15	275	11/8/6	25	7/5/3	21
	.20	320	12/9/7	30	8/6/4	25
	.25	355	13/10/8	34	9/6/4	28
10"	.05	260	9/7/5	15	7/6/4	<15
	.10	370	11/8/6	23	9/7/5	18
	•.12	402	12/9/7	25	9/7/5	20
	.15	450	13/10/8	27	10/8/6	22
	.20	520	14/11/9	31	11/9/7	26
	.25	580	15/12/10	34	12/10/7	29
12"	.05	350	11/8/6	15	7/6/4	<15
	.10	470	13/10/8	23	9/7/5	19
	.15	560	15/12/10	27	10/8/6	23
	•.16	576	15/12/10	28	10/8/6	24
	.20	640	16/13/11	31	12/10/8	27
	.25	720	17/14/12	34	14/11/9	30

• Denotes 750 fpm / 3.81 m/s inlet velocity.

\* Throw data is for air 20°F/11°C lower than room temperature. Throws for isothermal air are 40 to 50% greater.

† NC based on L<sub>w</sub>(10<sup>-12</sup> watts reference) -10db

Tested in accordance with ANSI/ASHRAE 70, ANSI S12.31, ARI 890, ISO 5219 and ISO 3741.

When using Acutherm directional baffles for other than four-way blow patterns, reduce the maximum air volume as shown in Acutherm document 091.201 (formerly document 50.2).

PERFORMANCE GUIDE in SI (METRIC) UNITS

Inlet Designation	Nominal Inlet Dia. mm	Inlet Static Pressure Pa	Maximum Flow		Maximum Flow Throw (m)*@V <sub>t</sub> =				25% Maximum Flow Throw (m)*@V <sub>t</sub> =			
			L/s	m <sup>3</sup> /h	.25 m/s	.50 m/s	.75 m/s	†NC	.25 m/s	.50 m/s	.75 m/s	†NC
6	150	10	43	157	1.7	1.2	.9	< 15	.9	.6	.3	< 15
		20	59	211	2.2	1.4	1.1	18	1.1	.8	.5	16
		• 30	73	262	2.6	1.7	1.4	22	1.3	1.0	.7	19
		40	85	307	2.8	1.9	1.6	27	1.6	1.3	.9	22
		50	95	341	2.8	2.2	1.8	31	1.8	1.5	.9	24
		60	102	368	3.0	2.4	2.1	33	2.1	1.8	1.2	26
8	200	10	69	250	2.3	1.8	1.2	< 15	1.5	.9	.6	< 15
		20	94	339	2.8	2.0	1.4	18	1.7	1.1	.8	16
		• 30	116	417	3.2	2.3	1.7	22	2.0	1.4	.9	18
		40	134	484	3.4	2.5	1.9	26	2.2	1.6	1.0	22
		50	151	545	3.7	2.8	2.2	30	2.5	1.8	1.2	25
		60	165	593	3.9	3.0	2.4	33	2.7	1.9	1.2	27
10	250	10	112	405	2.6	2.1	1.5	< 15	2.0	1.8	1.2	< 15
		20	154	556	3.1	2.3	1.7	20	2.5	2.0	1.4	17
		• 30	190	685	3.6	2.7	2.1	25	2.9	2.3	1.7	20
		40	219	791	4.0	3.1	2.5	28	3.1	2.5	1.9	23
		50	246	886	4.3	3.4	2.8	31	3.4	2.8	2.2	26
		60	269	968	4.5	3.6	3.0	33	3.6	3.0	2.2	28
12	300	10	154	555	3.2	2.3	1.7	< 15	2.0	1.8	1.2	< 15
		20	200	719	3.7	2.8	2.2	20	2.5	2.0	1.4	17
		30	239	861	4.2	3.3	2.7	25	2.9	2.3	1.7	21
		• 40	272	981	4.7	3.8	3.1	28	3.2	2.6	2.0	24
		50	303	1091	4.9	4.0	3.4	31	3.7	3.1	2.5	27
		60	333	1200	5.1	4.2	3.6	33	4.2	3.3	2.7	29

All SI (metric) ratings are soft conversions from I-P ratings

• Denotes 750 fpm / 3.81 m/s inlet velocity.

\* Throw data is for air 20°F/11°C lower than room temperature. Throws for isothermal air are 40 to 50% greater.

† NC based on L<sub>w</sub>(10<sup>-12</sup> watts reference) -10db

Tested in accordance with ANSI/ASHRAE 70, ANSI S12.31, ARI 890, ISO 5219 and ISO 3741.

When using Acutherm directional baffles for other than four-way blow patterns, reduce the maximum air volume as shown in Acutherm document 091.201 (formerly document 50.2).

Fig.2: Wiring

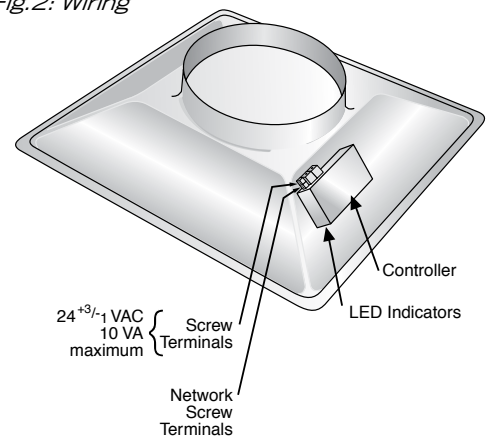

- Supply Air Temperature
- Air Flow

## Set Points

- Separate cooling and heating set points in each occupancy mode
- Offset for temporary vacancy (i.e. lunch break)
- Set limit on range of adjustment
- Reset on occupancy mode
- Mode Settings
- Occupancy modes; Occupied, Unoccupied and Standby
- VAV heating and cooling modes
- Vacancy modes

## Flow Settings

- Maximum flow
- Minimum flow
- Minimum flow standby
- Maximum flow heating only

## Overrides

- All built in sensors from external values
- Damper position; open, closed or flow setting

## Special Features

- Interface with CO2 sensor (by others) and purge room
- Terminal load

## SUPPLY POWER

24VAC +3/-1, 10VA Max

## OPEN FOR BALANCING

If the EF has not yet been connected to the network, an EF with a thermal actuator can be opened manually. To open, unhook the tension spring from the bracket adjacent to the cooling thermostat and turn the control plate slightly to drop the dampers open. If the network is in place at the time of balancing, the override open command may be sent to the diffuser.

An EF with an electric motor will be shipped in the open position to allow balancing prior to connection of power and network.

Fig.3: Identification Switch

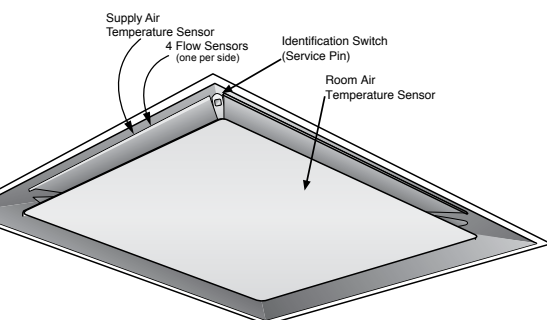

## SYSTEM DESIGN

The best control for heating/cooling units supplying air to VAV terminals is a discharge thermostat which maintains a constant supply air temperature. With DX equipment these are a high and low limit. Use a room thermostat for changeover between heating and cooling modes. For hybrid systems (part VAV and part constant volume) control the heating/cooling supply unit with a thermostat in one of the rooms with a constant volume diffuser, preferably the space with the greatest load. For both VAV and hybrid systems, the fan should run continuously.

The constant discharge velocity of Therma-Fuser diffusers at varying air flow provides good room circulation which reduces stratification. Keeping heating supply air temperatures as low as possible will further reduce room air stratification to a negligible level.

Static pressure at the inlet of the Therma-Fuser diffuser should be between .05"wg/12Pa and 0.25"wg/62Pa, at full and partial air flows. Static pressure below .05"wg/12Pa will result in low air flow and less induction. Above .25"wg/62Pa, Therma-Fuser diffusers operate well but excessive noise may result. Use minimum flow settings where tight shut off is not needed.

If the system turns down more than 30%, static pressure should be controlled. Included in the options for static pressure control are fan speed control and modulating bypass dampers. Modulating zone dampers are recommended where several zones share a higher pressure duct or riser.

When designing ducts, if Therma-Fuser diffusers are to deliver nominal volume at inlet SP of 0.15"wg/37Pa and if a maximum SP of 0.25"wg/62Pa is to be held for quiet operation, size the duct for a maximum pressure drop of 0.1"wg/25Pa between the first and last takeoff.

Manual balancing dampers should be used at the takeoff for each diffuser. Manual balancing dampers may not be required with ducts designed to Acutherm specifications.

Because Therma-Fuser diffusers control room temperature by sensing room air induced up the center of the space, care should be taken not to disturb room air induction and entrainment. For example, location next to walls or dropped lights results in the reflection of primary air back at the Therma-Fuser diffuser. Relocate either the Therma-Fuser diffuser or the light.

Acutherm has "how to" system design brochures for almost every ducted air system. For specific recommendations refer to the brochure for your system.

## GUIDE SPECIFICATION

(Suitable for Section 23 36 16 Variable-Air-Volume Units of the CSI MasterFormat). Sections in italics show different options - delete the option that does not apply.

### 2.2 DDC Interoperable VAV Diffusers

- DDC Interoperable variable air volume diffusers shall be Therma-Fuser™ model EF manufactured by Acutherm, Hayward CA.
- DDC Interoperable VAV diffusers shall be a complete VAV terminal with room air sensor, supply air sensor, flow sensors, "expert system" controller, actuator and four dampers contained in a nominal 2'x2'/600mm square diffuser.
- They shall be:
  - Native BACnet™ and BTL® Listed for interoperability on any BACnet® network. - **OR** -
  - LonMark® certified for interoperability on any LonWorks® network, conform to LonMark® Functional Profile ID:8010 and shall provide all optional and mandatory network and configuration variables (except the inapplicable internal heater and internal fan control options).
- They shall be actuated by:
  - A no maintenance thermal actuator wrapped with a resistance heater and a manual disconnect which will open the dampers for balancing should the diffuser not yet be connected to the network. - **OR** -
  - A brushless DC stepper motor with a direct linkage to the damper shipped in the open position for balancing should the diffuser not yet be connected to the network.
- Flow sensors shall accurately measure flow regardless of radius of the inlet elbow or direction of the supply air duct. No sensor, mechanism or other part shall extend above the inlet of the diffuser to avoid interfering with duct installation and allow installation of a fire damper.
- The expert controller shall have the ability to change control response as the space changes. P, PI, PD and PID control shall not be acceptable. The controller shall be field configured as either VAV heating/cooling or VAV cooling.
- The VAV diffusers shall have four perimeter dampers to provide 66 linear inches/1676 mm of variable discharge area at the perimeter of the diffuser for maximum Coanda effect and to avoid dumping. The housing shall have an offset ridge on each of the four edges to provide better air flow in lay in installations.
- All VAV diffusers shall have a solid (no holes or slots), hinged appearance panel that can be unlatched and folded down to hang allowing hands to be free for adjusting temperature set points. Instructions for the VAV diffuser shall be on the inside of the appearance panel.
- The VAV diffusers shall have positive induction of secondary room air over the room air sensor at all flows from fully closed to fully open.
- The manufacturer shall warrant that all VAV diffusers shall be free from defects in materials and workmanship for a period of two years from date of shipment.
- Supply air to the VAV diffuser shall be constant temperature (may be reset to another constant temperature). Supply air shall be limited to no lower than 50°F/10°C on cooling and no higher than 120°F/49°C on heating. The heating high limit shall be as low as possible but no lower than 80°F/27°C.





# EF Therma-Fuser™ Interoperable Square VAV Diffuser

## TWO YEAR WARRANTY

Acutherm warrants that its EF Therma-Fuser diffusers, exclusive of any options and accessories (whether factory or field installed) shall be free from defects in material or workmanship for a period of two (2) years from the date of shipment and agrees to repair or replace, at its option, any parts that fail during said two (2) year period due to any such defects which would not have occurred had reasonable care been taken, provided that such parts have been inspected by Acutherm and found defective and provided the diffusers have been given normal and proper usage and all parts and controls remain unaltered. Acutherm makes NO WARRANTY OF MERCHANTABILITY OF PRODUCTS OR OF THEIR FITNESS FOR ANY PURPOSE OR ANY OTHER EXPRESS OR IMPLIED WARRANTY WHICH EXTENDS BEYOND THE LIMITED WARRANTY ABOVE. ACUTHERM'S LIABILITY FOR ANY AND ALL LOSSES AND DAMAGES RESULTING FROM DEFECTS SHALL IN NO EVENT EXCEED THE COST OF REPAIR OR REPLACEMENT OF PARTS FOUND DEFECTIVE UPON EXAMINATION BY ACUTHERM. IN NO EVENT SHALL ACUTHERM BE LIABLE FOR INCIDENTAL, INDIRECT OR CONSEQUENTIAL DAMAGES OR DAMAGES FOR INJURY TO PERSONS OR PROPERTY. Acutherm shall not be responsible for freight to or from its plant in connection with the inspection, repair or replacement of parts under the terms of this limited warranty nor for cost of removal or installation

Protected by U.S. Patents 6,250,560 & 6,581, 847

## ACUTHERM PRODUCT GUIDE



Square VAV Diffusers



Round VAV Diffusers



Linear VAV Diffusers



Accessories



Pressure Control



Temperature control

## PRODUCT INFORMATION DESCRIPTION

Use the following model number nomenclature to order Therma-Fuser diffusers, options and accessories.

### Product

(1) Model	(2) Protocol	(3) Actuator	(4) Size	Product
EF				1. Model: <b>EF</b> – Square Therma-Fuser diffuser 2. Protocol: <b>B</b> BACnet™, <b>L</b> LonTalk® 3. Actuator: <b>T</b> Thermal Actuator, <b>M</b> Electric Motor 4. Size: <b>6, 8, 10, or 12</b> inch inlet

### Options

(1) Insulation	(2) Security Hanger	(3) Sheared Housing	(4) Blow Patterns	(5) Silk Screen	Options
					1. Insulation: <b>I</b> for attic side insulation 2. Security Hanger: <b>H</b> 3. Sheared Housing: <b>595</b> for 600mm metric grid ceilings, <b>T1</b> for 23 <sup>3</sup> / <sub>16</sub> " and <b>T2</b> for 22 <sup>3</sup> / <sub>4</sub> " 4. Blow Patterns: <b>TFD3</b> for 3-way blow, <b>TFD2C</b> for 2-way blow corner, <b>TFD2</b> for 2-way blow opposite, and <b>TFD1</b> for 1-way blow. 5. Silk Screen: <b>S</b> for appearance panel pattern

### Accessories

(1) Ceiling Frame	Accessories
	1. Ceiling Frame: <b>TFHD</b> for hard ceiling, <b>TF4DB</b> for 4" drop box, <b>TF1DB</b> for 1 <sup>7</sup> / <sub>16</sub> " drop box, <b>TFSP</b> for spline, <b>TFT1</b> for tegular 9/16" T-bar, <b>TFT2</b> for tegular 1" T-bar, and <b>TFAL</b> for air lifter (no ceiling)

## AVAILABLE ONLINE

Access digital brochures, CAD files, performance data and more!

[www.acutherm.com](http://www.acutherm.com)

## CALL US

Talk to our customization and specification experts

+1 800 544 1840



## EMAIL SUPPORT

Send us your questions and we'll get you the answers you need.

[info@acutherm.com](mailto:info@acutherm.com)