

Donaldson<sup>®</sup>  
Torit<sup>®</sup>

**DOWNFLO<sup>®</sup> II  
DUST COLLECTORS**

**ULTRA-WEB<sup>®</sup>**  
High Efficiency **Nanofiber Filters** Built to Last



# ENGINEERED FOR RELIABLE PERFORMANCE

The long-standing, most influential cartridge collector in industrial air filtration history, the Donaldson® Torit® Downflo® II (DFT), delivers optimum performance and is one of the best values available in today's marketplace. A leader in the industry for over 20 years with thousands of successful installations in place, DFT dust collectors ensure steadfast, trouble-free operation.

The DFT advantages can be found in the collector's proprietary design and components. Now featuring a ledgeless design in combination with proprietary Ultra-Web® filter media and proprietary cleaning technology, the DFT continues its strong performance in traditional applications such as metalworking. It also generates interest and respect in process applications where ledgeless construction is often a requirement. Providing higher efficiency and smaller footprints than any baghouse collector or even other cartridge collectors, DFT adds up to long-term savings and improved performance in many applications.

## DFT Offers:

- **LEDGELESS CONSTRUCTION**  
Eliminates dust build-up and accommodates wash down environments
- **COMPACT DESIGN**  
Minimizes floor space.
- **POWERFUL PERFORMANCE**  
Proprietary ExtraLife™ Filter Cleaning System provides 30% more cleaning energy
- **COST SAVINGS**  
Fewer filter changeouts, reduced filter disposal costs, less energy usage
- **RELIABILITY**  
Exceptional results for over 20 years and counting
- **EASY SYSTEM SETUP**
- **EASY MAINTENANCE**
- **10-YEAR WARRANTY**

**A LEADER**  
IN THE INDUSTRY FOR OVER  
**20 YEARS**

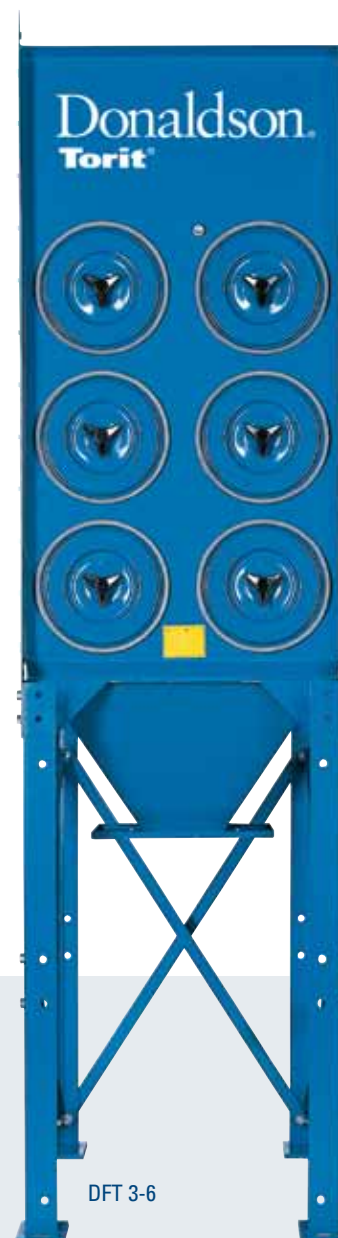

# SIZES & OPERATIONS

## NORMAL OPERATION

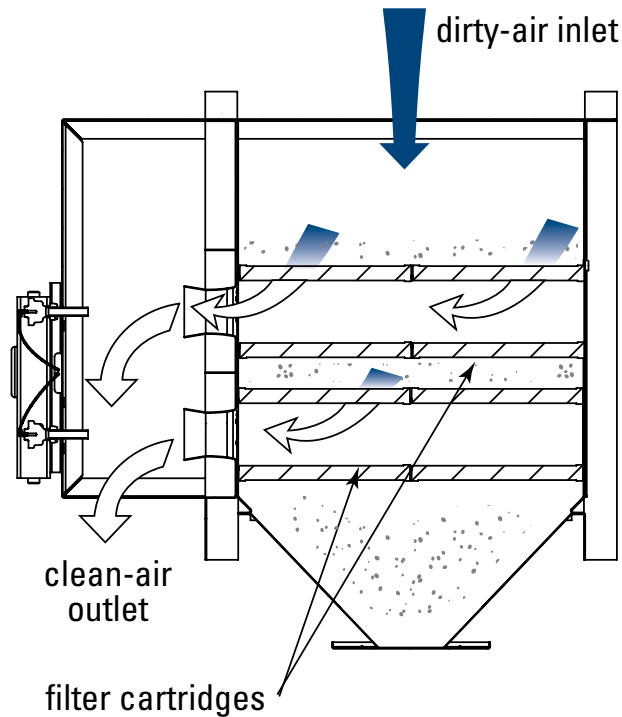

## PULSE CLEANING TECHNOLOGY

ExtraLife Filter Cleaning System uses proprietary, computer-modeled pulse cleaning technology to easily “pulse off” dust from the surface of the filter, improving filtration efficiency and prolonging filter life. The red lines in the illustration show the increased pressure at the front of the Downflo filter generated by the ExtraLife system. The blue line shows the pulse signature of a standard cartridge collector.

Pulse gradients produced by the standard Downflo during pulse cleaning compared to gradients produced by a Downflo with the ExtraLife Cleaning System (red).

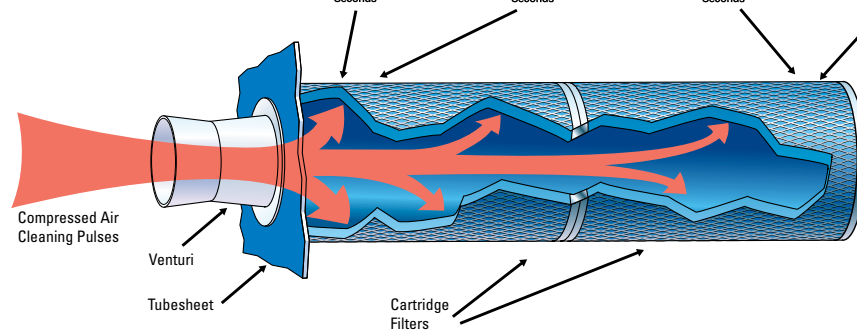
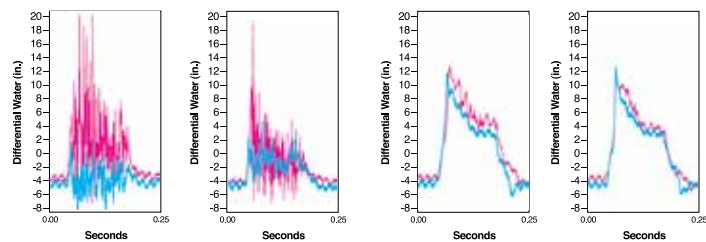

## DOWNFLO PULSE PRESSURE GRADIENTS

# DIMENSIONS & SPECIFICATIONS

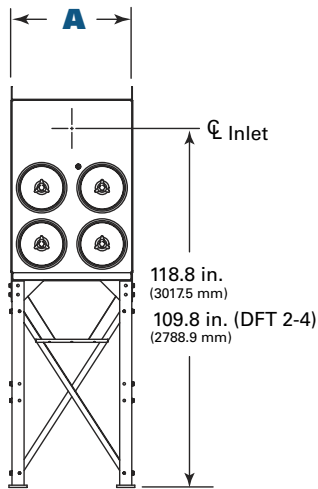

Front View  
DFT 2-Models

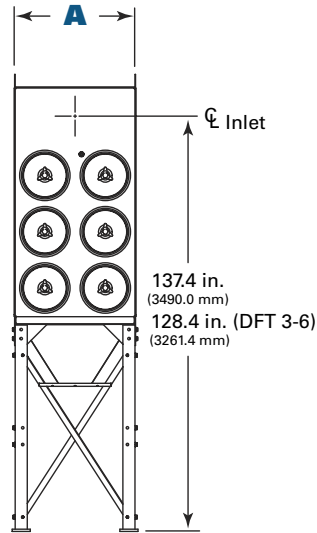

Front View  
DFT 3-Models

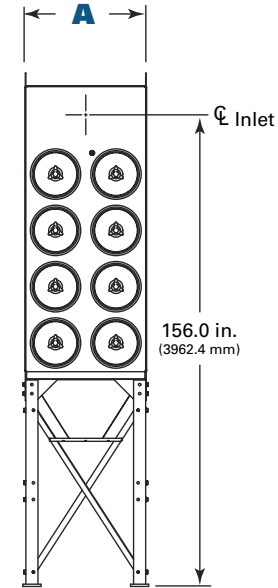

Front View  
DFT 4-Models

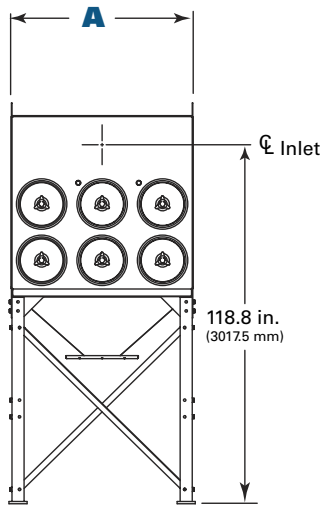

Front View  
DFT 2-12  
(3-Wide Models)

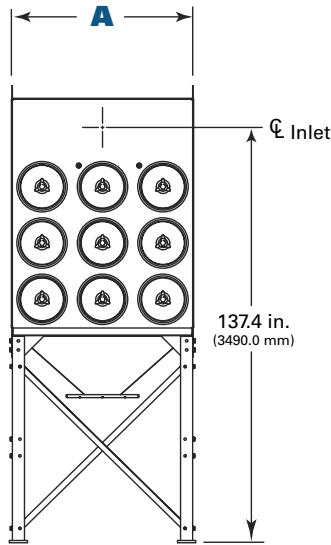

Front View  
DFT 3-18  
(3-Wide Models)

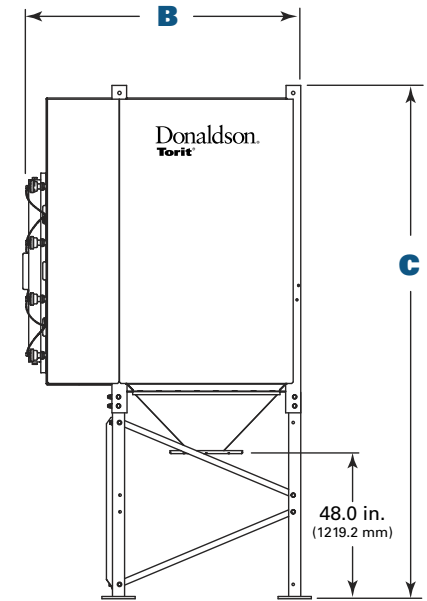

Left Side View  
All Models

## DFT STANDARD OPERATING CONDITIONS

Seismic Rating (zone)	4	Compressed Air Required (psi/bar)	90-100/6.2-6.9
Wind Load Rating (mph/kph)	100/161	Valves and Controls	50/60 KHz
Housing Rating (in of H <sub>2</sub> O/mm of H <sub>2</sub> O)	[+15/-20] / [+381/-508]		

DFT Model*	Nominal Airflow Range**		No. of Filters	Ultra-Web Filter Area		No. of Valves	Approx. Shipping Weight***		Dimensions					
									A		B		C	
	cfm	m <sup>3</sup> /h		ft <sup>2</sup>	m <sup>2</sup>		lb	kg	in	mm	in	mm	in	mm
2-4	500-3,150	849-5,351	4	1016	94.4	4	1,700	771.1	40.0	1016.0	67.8	1722.1	117.3	2979.4
2-8	1,020-6,300	1,733-10,701	8	2,032	188.8	4	1,700	771.1	40.0	1016.0	94.5	2400.3	132.7	3370.6
2-12	1,525-9,450	2,590-16,052	12	3,048	283.2	6	2,400	1,088.6	60.0	1524.0	94.5	2400.3	132.7	3370.6
2-16	2,030-12,600	3,448-21,403	16	4,064	377.5	8	3,300	1,496.9	80.0	2032.0	94.5	2400.3	132.7	3370.6
2-24	3,050-18,900	5,181-32,104	24	6,096	566.3	12	4,600	2,086.5	120.0	3048.0	94.5	2400.3	132.7	3370.6
2-36	4,570-28,350	7,763-48,157	36	9,144	849.5	18	7,000	3,175.1	180.0	4572.0	94.5	2400.3	132.7	3370.6
3-6	760-4,720	1,291-8,018	6	1,524	141.6	6	1,700	771.1	40.0	1016.0	64.5	1638.3	136.0	3454.4
3-12	1,525-9,450	2,590-16,052	12	3,048	283.2	6	2,100	952.5	40.0	1016.0	94.5	2400.3	151.3	3843.0
3-18	2,285-14,175	3,881-24,078	18	4,572	424.7	9	2,900	1,315.4	60.0	1524.0	94.5	2400.3	151.3	3843.0
3-24	3,050-18,900	5,181-32,104	24	6,096	566.3	12	4,200	1,905.1	80.0	2032.0	94.5	2400.3	151.3	3843.0
3-36	4,570-28,350	7,763-48,157	36	9,144	849.5	18	6,100	2,766.9	120.0	3048.0	94.5	2400.3	151.3	3843.0
3-48	6,100-37,800	10,362-64,209	48	12,192	1,132.6	24	8,000	3,628.7	160.0	4064.0	94.5	2400.3	151.3	3843.0
3-54	6,850-42,520	11,636-72,227	54	13,716	1,274.2	27	8,500	3,855.5	180.0	4572.0	94.5	2400.3	151.3	3843.0
3-60	7,620-47,240	12,944-80,244	60	15,240	1,415.8	30	10,100	4,581.3	200.0	5080.0	94.5	2400.3	151.3	3843.0
3-72	9,140-56,700	15,526-96,313	72	18,288	1,699.0	36	12,000	5,443.1	240.0	6096.0	94.5	2400.3	151.3	3843.0
4-16	2,030-12,600	3,448-21,403	16	4,064	377.5	8	2,500	1,134.0	40.0	1016.0	94.5	2400.3	169.9	4315.5
4-32	4,060-25,200	6,897-42,806	32	8,128	755.1	16	4,600	2,086.5	80.0	2032.0	94.5	2400.3	169.9	4315.5
4-48	6,100-37,800	10,362-64,209	48	12,192	1,132.6	24	6,500	2,948.4	120.0	3048.0	94.5	2400.3	169.9	4315.5
4-64	8,130-50,390	13,810-85,595	64	16,256	1,510.2	32	8,500	3,855.5	160.0	4064.0	94.5	2400.3	169.9	4315.5
4-80	10,160-62,990	17,258-106,998	80	20,310	1,886.8	40	10,300	4,672.0	200.0	5080.0	94.5	2400.3	169.9	4315.5
4-96	12,190-75,590	20,707-128,401	96	24,384	2,265.3	48	12,100	5,488.5	240.0	6096.0	94.5	2400.3	169.9	4315.5
4-112	14,220-88,190	24,155-149,804	112	28,448	2,642.8	56	14,500	6,577.1	280.0	7112.0	94.5	2400.3	169.9	4315.5
4-128	16,260-100,790	27,620-171,207	128	32,512	3,020.4	64	16,000	7,257.5	320.0	8128.0	94.5	2400.3	169.9	4315.5

\* The first number indicates number of filter rows, and the second number indicates number of cartridges.

\*\* Based on clean filters.

\*\*\* Without accessories or optional equipment.

# CARTRIDGE FILTER TECHNOLOGY

## ULTRA-WEB® NANOFIBER FILTER MEDIA

Donaldson leverages almost 100 years of air filtration experience in the development of filtration media, providing tremendous value to our customers. Ultra-Web® media incorporates a durable layer of premium nanofiber designed to intercept the smallest dust particles at the surface of the media.

Independent laboratory testing determined that Ultra-Web media has a Minimum Efficiency Reporting Value (MERV) of 15 based on the ASHRAE 52.2-2007 test standard. Ultra-Web media rated MERV 15 is the most optimized, balanced and cost-effective media in the marketplace, providing higher efficiency without compromising pressure drop and filter life. For more information on Ultra-Web and MERV ratings, please visit [www.ultrawebisalwaysbetter.com](http://www.ultrawebisalwaysbetter.com).



**Nanofiber Media**  
(600x)

Nanofiber surface loading technology is available in all Ultra-Web and Fibra-Web cartridge filters.



**Commodity Filter Media**  
(600x)

Conventional media has spaces of up to 60 µm between fibers, allowing dust to become deeply embedded.

## SYSTEM ENERGY EFFICIENCY, SAVINGS, AND NOISE CONTROL

Surface loading is a key characteristic of Donaldson's Ultra-Web media. This surface loading capability improves the effectiveness of pulse cleaning, which minimizes system pressure differential; thereby conserving compressed air usage and brake horsepower requirements of the system fan.

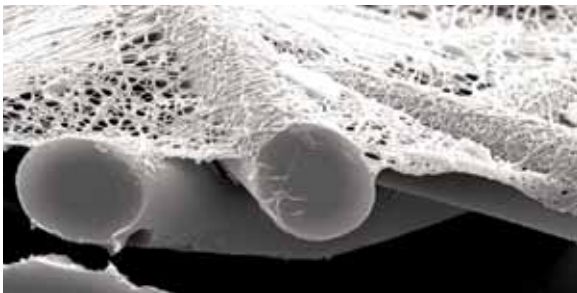

**Clean Ultra-Web Filter**

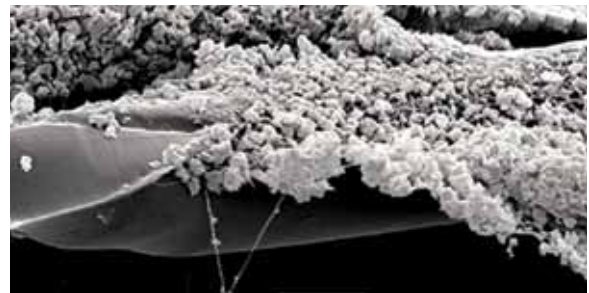

**Surface-Loaded Ultra-Web Filter**  
(substrate still clean)

Ultra-Web nanofiber media is loaded with ISO fine dust. Dust particles collect on the surface of the media and clean off easily while the substrate stays clean. A depth-loading filter would allow dust particles to penetrate deeply into the substrate where they build up and choke off the airflow.

## DFT CARTRIDGE FILTERS

DFT dust collectors' proprietary downward airflow design delivers highest filtration performance while using less energy. The DFT collector, its proprietary ExtraLife Filter Cleaning System, and Donaldson Torit's cartridge filters together are an unbeatable system. Choose from our superior line of filters to complete the most powerful dust collection solution available.

# STANDARD FEATURES & AVAILABLE OPTIONS

Collector Design	Std	Opt
Mild Steel Construction	X	
ExtraLife™ Filter Cleaning System	X	
Inlets	X	
Ledge-Free Hopper	X	
Sprinkler Taps	X	
Stainless Steel Construction		X
High Temperature Construction		X
Direct Drive Fans		X
Chamber and Exhaust Silencers		X
Abrasion Resistant (AR) Inlet		X
Air Management Modules		X
Extended Dirty Air Plenum		X
Steep-Sided Hopper		X
2-Mod Hopper		X
Explosion Relief Vents		X
Sprinkler Heads		X
Service Platform (OSHA compliant)		X
Damper Pack		X
Drum Sentry™ Drum-Full Indicator		X
Lined Clean Air Plenum		X
Bag-Out Kit (Filter & Discharge)		X
Bag-In/Bag-Out Kit (Filter & Discharge)		X
<b>Cartridge Filters</b>		
Ultra-Web® (MERV* 15)	X	
Ultra-Tek® (MERV 12)		
Thermo-Web® (MERV 14)		
Fibra-Web® (MERV 14)		X
Ultra-Web SB (MERV 15)		
Torit-TEX™ (MERV 16)		
HEPA/ASHRAE Afterfilters		X

Paint System	Std	Opt
Prime Coated Interior	X	
Textured Multi-Coat Paint Finish with 2,000-Hour Salt Spray Performance	X	
Custom Color		X
Premium Duty Finish		X
Epoxy Coating		X
<b>Hopper Discharge</b>		
Drum Cover and Hose		X
Slide Gates		X
Rotary Valves and Transitions		X
Screw Conveyors		X
<b>Electrical Controls, Gauges &amp; Enclosures</b>		
Solid State Timer in NEMA 4 Enclosure	X	
Magnehelic®** Gauge	X	
Delta P Control, Delta P Plus Control		X
Custom Panels		X
Photohelic®** Gauge Standard & Weatherproof		X
Basic Cold Climate Kit		X
Heavy-Duty Cold Climate Kit		X
Solenoid Enclosure (NEMA 7 & 9)		X
<b>Warranty</b>		
10-Year Warranty	X	

\* The Minimum Efficiency Reporting Value (MERV) of this filter cartridge has been determined through independent laboratory testing using ASHRAE 52.2 (2007) test standards. The MERV rating was determined at a face velocity of 118 feet (36.0 m) per minute and loading up to four inches (101.6 mm) water gauge. Actual efficiency of any filter cartridge will vary according to the specific application parameters. Dust concentration, airflow, particle characteristics, and pulse cleaning methods all affect filtration efficiency.

\*\* Magnehelic and Photohelic are registered trademarks of Dwyer Instruments, Inc.

## Global Support

- Facilities in 37 countries
- 40 manufacturing plants and 14 distribution centers

## Leading Technology

- Over 1,000 engineers and scientists worldwide
- Broad range of innovative collectors and filters
- 100s of filter media formulations

## Experience and Service

- Technical expertise and support
- Ready-to-ship filters and parts within 24 hours
- 1,000,000+ dust, fume and mist collectors installed

Call Donaldson® Torit® to get cleaner air today:

**800-365-1331**

[DonaldsonTorit.com](http://DonaldsonTorit.com)



Tel 800-365-1331 (USA)  
Tel 800-343-3639 (within Mexico)  
[donaldsonorit@donaldson.com](mailto:donaldsonorit@donaldson.com)  
[donaldsonorit.com](http://donaldsonorit.com)

Donaldson Company, Inc.  
Torit  
P.O. Box 1299  
Minneapolis, MN  
55440-1299 U.S.A.

### **EXACTLY WHAT YOU NEED.™**

**Downflo II Dust Collector Brochure (06/12)**  
© 2003 Donaldson Company, Inc. All Rights Reserved. All products, product specifications, and data (airflow, capacity, dimensions, or availability) are subject to change without notice, and may vary by region or country. Donaldson Torit, Downflo, Ultra-Web, and the color blue are registered trademarks of Donaldson Company, Inc. Contains Donaldson proprietary technology.