

Pump Data

5HP 6-5/8 Imp. Single Stage Centrifugal Pump

Built-In Overload With Auto-Reset Provided

23amp 230V Single Phase UL Motor

2" Flange Suction

Pump Flow

GPM	0	30	40	60	80	100
PSI	71	68	67	63	55	52

Model F-SH5-RC

Attention! This package uses an un-listed pump.
For 13R application, be sure AHJ has approved use!

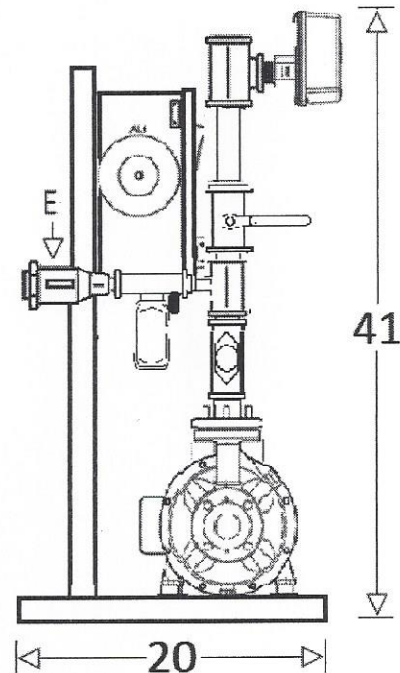

Components

- A. Flow Switch
- B. 1-1/2 F IPT Galvanized Riser
- C. UL Listed Residential Fire Pump Controller
- D. Supervised Control Valve
- E. Bypass Line with 3/4 F IPT Backflow Preventer
- F. Manual back up Water Pressure Gauge
- G. Electronic Pressure Transducer
- H. Powder Coated Steel Frame
- I. SH5 HP UL Motor Stainless Pump

Optional equipment

- J. 1-1/2 Butterball Tamper Switch

