



MRX4000 PLUS

*High Performance Analog + Digital
Integrated Receiver Decoder (IRD)*



Manual Part No. 400537-1
Rev. B May 2008

Operator's Guide

Notices

About This Manual

Part number **400537-1**

Revision **B May 2008**

The information in the manual applies to the Microwave Radio Communications (MRC) MRX4000 PLUS High Performance Analog + Digital Integrated Receiver Decoder (IRD).

Copyright

The information in this manual may only be reproduced by the purchaser strictly for its own internal use to the extent required for its use of the product, and shall only be made available to purchaser's employees who need access to this material. No part of this material, nor any copies hereof, shall in any manner be disclosed, disseminated, or made available by purchaser or its employees to any other person, firm, or entity without the express prior written consent of Microwave Radio Communications nor shall the same in any manner be modified or published for resale without the express prior written authorization of Microwave Radio Communications.

© 2008 Microwave Radio Communications

Microwave Radio Communications

101 Billerica Avenue - Bldg. 6

North Billerica, MA 01862-1256 USA

TEL: 800.490-5700

978.671.5700

FAX: 978.671.5800

Printed in U.S.A.

Adobe®, the Adobe logo, Acrobat®, and Reader® are registered trademarks of Adobe Systems, Inc. in the United States and/or other countries. Microsoft® and Windows® are registered trademarks of Microsoft Corporation in the United States and/or other countries.

Proprietary Material

The information and design contained within this manual was originated by and is the property of Microwave Radio Communications. Microwave Radio Communications reserves all patent proprietary design, manufacturing, reproduction use, and sales rights thereto, and to any articles disclosed therein, except to the extent rights are expressly granted to others. The foregoing does not apply to vendor proprietary parts.

Microwave Radio Communications has made every effort to ensure the accuracy of the material contained in this manual at the time of printing. As specifications, equipment, and this manual are subject to change without notice, Microwave Radio Communications assumes no responsibility or liability whatsoever for any errors or inaccuracies that may appear in this manual or for any decisions based on its use. This manual is supplied for information purposes only and should not be construed as a commitment by Microwave Radio Communications.

Quality Certification

Microwave Radio Communications is certified to ISO 9001:2000.
Authorized EU representative: Vislink PLC.

Conventions

Pay special attention to information marked in one of the following ways:

WARNING Follow WARNINGS closely to prevent personal injury or death.

CAUTION Follow CAUTIONS to prevent damage to the equipment.

Note Notes provide additional information to assist you in using and maintaining the equipment.

Waste Electrical and Electronic Equipment



The crossed out dustbin symbol on the product indicates that the product must not be disposed of with other waste at the end of its lifecycle. Instead, it is the user's responsibility to dispose of the waste equipment by handing it over to a designated collection point for the recycling of Waste Electrical and Electronic Equipment (WEEE). For more information about where you can drop off your waste equipment for recycling, please contact your local government office.

Except for this notification and the proper marking of products with the appropriate symbol, Microwave Radio Communications

disclaims responsibility for the disposal of its products per the WEEE directive.

Symbols Used

The following symbols are used on the equipment:

Symbol	Meaning
	WARNING: General Warning. Risk of Danger.
	WARNING: Risk of Electric Shock.
	WARNING: Electrostatic Discharge. Possible Damage to Equipment.
	Fuse - Identifies fuses or their location.
OR 	
	Frame or Chassis Ground - Identifies the frame or chassis terminal.
	Earth Ground - Identifies the earth ground terminal.
	Protective Earth Ground - Identifies any terminal which is intended for connection to an external conductor for protection against electric shock in case of a fault, or the terminal on a protective earth electrode.

On-Line Viewing

Text displayed as **blue** contains a hypertext link. Click on the **hypertext** to jump to that destination. Click on the **blue destination** to return.



Viewing this manual on-line requires Adobe Acrobat or Adobe Reader, version 5.0 and later.



Click on this icon to download your FREE copy of Adobe Reader.

Warranty Information

Products Manufactured by MRC

- a.** Products manufactured by MRC are warranted against defects in material and workmanship for a period of two (2) years from date of delivery as evidenced by MRC's packing slip or other transportation receipt (unless otherwise noted).
- b.** MRC's sole responsibility under this warranty will be to either repair or replace, at its option, any component which fails during the applicable warranty period because of a defect in material or workmanship, provided Buyer has promptly reported same to MRC in writing. All replaced products and parts will become MRC's property.
- c.** MRC will honor the warranty at the repair facility designated by MRC. It is Buyer's responsibility to return, at its expense, the allegedly defective product to MRC. Buyer must obtain a Return

Material Authorization (RMA) number and shipping instructions from MRC prior to returning any product under warranty. Transportation charges for the return of the product to Buyer will be paid by MRC within the United States. For all other locations, the warranty excludes all costs of shipping, customs clearance, and other related charges. If MRC determines that the product is not defective within the terms of this warranty, Buyer will pay MRC all costs of handling, transportation, and repairs at the then prevailing repair rates.

- d.** All the above warranties are contingent upon proper use of the product. These warranties will not apply (1) if adjustment, repair, or product or parts replacement is required because of accident, unusual physical, electrical or electromagnetic stress, neglect, misuse, failure of electric power, environmental controls, transportation, failure to maintain properly, or otherwise in accordance with MRC specifications, or abuses other than ordinary use; (2) if the product has been modified by Buyer or has been repaired or altered outside MRC's repair facility, unless MRC specifically authorizes such repairs or alterations in each instance; or (3) where MRC serial numbers, warranty data, or quality assurance decals have been removed or altered.
- e.** Equipment shipped FOB from Microwave Radio Communications shall become the property of the buyer upon delivery and receipt from the carrier. Any damage in shipment should be handled by the buyer directly with the carrier. Immediately request the carrier's inspection upon evidence of damage during shipment. Do not return any Microwave Radio Communications product to the factory until a Return Material Authorization (RMA) number and shipping instructions have been provided.
- f.** No person, including any dealer, agent, or representative of MRC, is authorized to assume for MRC any other liability on its behalf except as set forth herein. If any payment is due MRC for

services performed hereunder, it will be subject to the same payment terms as the original purchase.

Products Manufactured By Others

For products not manufactured by MRC, the original manufacturer's or licensor's warranty will be assigned to Buyer to the extent permitted by the manufacturer or licensor and is in lieu of any other warranty, expressed or implied. For warranty information on a specific product, a written request should be made to MRC.

All Products

THE FOREGOING WARRANTIES AND REMEDIES ARE EXCLUSIVE AND ARE IN LIEU OF ALL OTHER EXPRESS OR IMPLIED WARRANTIES, OBLIGATIONS, AND LIABILITIES ON THE PART OF MRC. EXCEPT FOR THE EXPRESS WARRANTIES STATED HEREIN, MRC DISCLAIMS ALL WARRANTIES ON PRODUCTS FURNISHED HEREUNDER, INCLUDING, WITHOUT LIMITATION, ALL IMPLIED WARRANTIES OF MERCHANTABILITY AND FITNESS FOR A PARTICULAR PURPOSE. MRC WILL HAVE NO RESPONSIBILITY FOR ANY PARTICULAR APPLICATION MADE OF ANY EQUIPMENT.

Any description of equipment, whether in writing or made orally by MRC or its agents, specification sheets, models, bulletins, drawings, or similar materials used in connection with Buyer's order are for the sole purpose of identifying the equipment and will not be construed as an express warranty. Any suggestions by MRC or its agents regarding use, application, or suitability of the equipment will not be construed as an express warranty. No warranties may be implied from any course of dealing or usage of trade. Buyer agrees that the exclusion of all warranties, other than those expressly provided herein, is reasonable.

Contents

Notices	i
About This Manual	i
Copyright	i
Proprietary Material	i
Quality Certification	i
Conventions	ii
Waste Electrical and Electronic Equipment	ii
Symbols Used	ii
On-Line Viewing	iii
Warranty Information	iii
Products Manufactured by MRC	iii
Products Manufactured By Others	iv
All Products	iv
Contents	1
Introduction	1-1
Chapter Overview	1-1
How to Use This Manual	1-1
What This Manual Covers	1-1
How It's Organized	1-1
For Whom It's Written	1-2
Related Documents	1-2
Ordering Documentation	1-2
Calling for Service	1-3
Supported Repairs	1-3
Tell Us What You Think!	1-4
Product Description	2-1
Chapter Overview	2-1
System Descriptions	2-1
MRX4000 PLUS Description	2-1
MRX4000 PLUS Configuration Options	2-2
Configuration Descriptions	2-2

Power Options	2-5
Mounting and Deployment Options	2-5
System Operation	2-5
MRX4000 PLUS Configurations	2-6
MPEG/COFDM Digital Configuration	2-6
FMR NTSC/PAL Analog Configuration	2-6
MPEG/COFDM/FMR NTSC/PAL Digital + Analog Configuration	2-6
For More Information	2-6
Routine Operation	3-1
Chapter Overview	3-1
Overview of Controls, Indicators and Connectors	3-1
Controls and Indicators	3-1
MRX4000 PLUS Digital and Digital + Analog Configuration Connectors	3-3
MRX4000 PLUS Analog Configuration Connectors	3-5
Preparing for Operation	3-7
Fixed or Mobile Installation	3-7
Powering the MRX4000 PLUS	3-7
Using the MRX4000 PLUS Screens	3-8
Overview	3-8
Menu Configurations	3-11
Main Screen	3-11
Cursors	3-11
Accessing Menus	3-13
Monitoring Operations	3-13
Monitor/Change MPEG Settings	3-13
Monitor/Change Color Bars	3-16
Monitor/Change Audio Output Mode Setting	3-17
Monitor/Change NTSC Pedestal	3-18
Monitor/Change BISS Settings	3-20
Monitor Audio A	3-21
Monitor Audio B	3-23
Monitor Video Status	3-24

Monitor Chroma Status	3-25
Monitor Service Name	3-26
Monitor/Change COFDM Settings	3-28
Monitor/Change Bandwidth	3-30
Monitor Modulator Type	3-31
Monitor Forward Error Correction	3-32
Monitor Guard Interval	3-34
Monitor COFDM Metrics	3-35
Monitor/Change FMR Settings	3-37
Monitor/Change Video Filter	3-39
Monitor/Change Video Deviation	3-40
Monitor/Change Channel 1, 2, 3, or 4 Sub-Carrier Frequencies	3-42
Monitor/Enable/Disable Channel 1, 2, 3, or 4	3-43
Monitor/Enable/Disable Channel 1, 2, 3, or 4 Filtering	3-45
Monitor/Enable/Disable Channel 1, 2, 3, or 4 De- Emphasis	3-46
Monitor/Change MRX4000 PLUS RF/IF Section Settings	3-48
Monitor Channel Frequency	3-50
Monitor Received Carrier Level	3-51
Monitor Link Quality	3-52
Select Frequency Band	3-53
Monitor Channel Bandwidth	3-55
Select Channel and Offset	3-56
Change Filter Setting	3-58
Change Squelch Level	3-59
Change Analog/Digital Operation Mode	3-61
Change IF/RF Operation Mode	3-63
Monitor/Change System Menu Options	3-65
Monitor/Change Active Preset	3-67
Monitor Active Errors	3-67
Review Error Log	3-68

Review System Information	3-69
Perform System Reset	3-70
Front Panel vs. Configurator Software	3-71
Troubleshooting	4-1
Chapter Overview	4-1
Status LEDs	4-1
Error Codes	4-2
Glossary	A-1
Channels & Frequencies	B-1
Appendix Overview	B-1
Initial Factory Presets	B-1
6.4 to 7.1 GHz Channel Plan	B-1
12.7 to 13.25 GHz Channel Plan	B-2
US 2 GHz Reallocation - 12 MHz Channel Plan	B-2
MRX4000 PLUS Specifications	C-1
Index	1

1 Introduction

1.1 Chapter Overview

This chapter will introduce you to the Operator's Guide: what it covers, how it's organized, and for whom it's written.

1.2 How to Use This Manual

A CD ROM, delivered with each MRX4000 PLUS High Performance Analog + Digital Integrated Receiver Decoder (IRD) (MRX4000 PLUS), contains PDF files for the Operator's Guide, Technical Reference Manual, and the Quick Reference Card.

The Operator's Guide, the Technical Reference Manual, and the Quick Reference Cards are also available for download through the MRC E-Synergy Customer Portal. For more information or to obtain a User Name and Password, please go to:

http://www.mrcglobalsolutions.com/support/e_synergy_portal

Hardcopies of the Operator's Guide and Technical Reference Manual are provided only if they were requested when your equipment was ordered.

Viewing of this manual on-line requires Adobe Acrobat software or Adobe Reader software, Version 5.0 and later. Click on the following icon to download your FREE copy of the latest Adobe Reader software.



When viewing this manual on-line, text displayed as **blue** contains a hypertext link. Click on the **blue hypertext** link to jump to that destination. If the destination link is also blue, click on the **blue destination** link to return.

1.3 What This Manual Covers

This manual describes how to operate the MRX4000 PLUS.

For information on Installation, Repair, Replacement Parts, and Theory of Operation, refer to the MRX4000 PLUS Technical Reference Manual

This manual also covers various configurations of the MRX4000 PLUS. Your MRX4000 PLUS will consist of one of the following configurations:

- MPEG/COFDM/FMR NTSC - Analog + Digital with RF/IF Section
- MPEG/COFDM/FMR PAL - Analog + Digital with RF/IF Section
- FMR NTSC - Analog Only with RF/IF Section
- FMR PAL - Analog Only with RF/IF Section
- MPEG/COFDM - Digital Only with RF/IF Section

Your MRX4000 PLUS will be rack-mounted in a standard 19-inch (43.9 cm) rack for fixed site operations.

1.4 How It's Organized

The manuals for the MRX4000 PLUS are organized as follows:

Chapter	Operator's Guide	Technical Reference Manual
Introduction	✓	✓
Product Description	✓	✓
Routine Operation	✓	✓
Troubleshooting	✓	✓
Advanced Operation		✓
Installation		✓
Repair		✓
Replacement Parts		✓
Theory of Operation		✓
Glossary	✓	✓
Channels and Frequencies	✓	✓
Configuration Utility		✓
MRX4000 PLUS Specifications	✓	✓

Note The Technical Reference Manual contains everything in the Operator's Guide, plus additional technical content.

1.5 For Whom It's Written

This manual is intended for use by qualified installers and service personnel. Users of this manual should already be familiar with basic concepts of radio, video, and audio.

1.6 Related Documents

- MRX4000 PLUS Technical Reference Manual (part no. 400538-1)
- MRX4000 PLUS Quick Reference Card (part no. 400539-1)

1.7 Ordering Documentation

Any of the above manuals may be ordered by contacting MRC Customer Service:

Business Hours: Monday - Thursday

8:00 AM - 7:00 PM Eastern Time (US)
(0800 - 1900 hrs US ET)

Friday

8:00 AM - 5:00 PM Eastern Time (US)
(0800 - 1700 hrs US ET)

Telephone: 800-490-5700 (Press 3)

978-671-5700 (Press 3)

Fax: 978-671-5948

E-mail: customerservice@mrcbroadcast.com

When contacting Customer Service, please have the following information available:

- Model number and serial number of the unit. This is located on a label on the left-hand side of each unit.
- Approximate purchase date.
- Firmware versions (depending upon the options contained in your MRX4000 PLUS), which appear on the MRX4000 PLUS alphanumeric display **System Menu > System Info > MRX DCC V:, Front Panel V:, MPEG V:, MPEG FPGA V:, COFDM V:, and FMR V:** menus.

or

- Firmware versions displayed on the **Main** page of the **MRX4000 PLUS Configuration Utility** (Configurator) software, when the Configurator is connected to the MRX4000 PLUS.

1.8 Calling for Service

MRC Technical Support is available 24 hours a day, 7 days a week. During regular business hours you can reach our expert staff directly.

Business Hours: Monday - Friday

8:00 AM - 7:00PM Eastern Time (US)

(0800 - 1900 hrs US ET)

Telephone: 800-490-5700 (Press 4)

978-671-5700 (Press 4)

Fax: 978-671-5948

E-mail: technicalsupport@mrcbroadcast.com

After regular business hours and on weekends and holidays, you can also reach our expert staff as follows:

Telephone: 978-671-5929

Your call will be automatically forwarded to the on-call Technical Support Specialist.

When contacting Technical Support, please have the following information available:

- Model number and serial number of the unit. This is located on a label on the left-hand side of each unit.
- Approximate purchase date.
- Firmware versions (depending upon the options contained in your MRX4000 PLUS), which appear on the MRX alphanumeric display **System Menu > System Info > MRX DCC V:, Front Panel V:, MPEG V:, MPEG FPGA V:, COFDM V:, and FMR V:** menus.

or

- Firmware versions displayed on the **Main** page of the **MRX4000 PLUS Configuration Utility** (Configurator) software, when the Configurator is connected to the MRX4000 PLUS.

1.9 Supported Repairs

The MRX4000 PLUS is designed to be compact, rugged, and reliable.

The MRX4000 PLUS requires specialized test equipment and software to calibrate amplitude and frequency characteristics after repair.

There are NO supported field repairs for the MRX4000 PLUS.

Return the entire unit for factory repair.

If you attempt field repair, you risk damaging your equipment. If your equipment is under warranty, you may also affect your warranty coverage.

1.10 Tell Us What You Think!

We'd appreciate any comments or suggestions you have about this manual. The more feedback we get, the better the manuals get!

If you're viewing this manual electronically, it's easy - just click on the link below to send us an E-mail.

[Feedback](#)

Or, you can E-mail our Technical Support team at:

technicalsupport@mrcbroadcast.com

Be sure to tell us what product you're writing about, and which manual - the Operator's Guide, the Quick Reference Card, or the Technical Reference Manual.

2 Product Description

2.1 Chapter Overview

This chapter provides an overall description of the MRX4000 PLUS High Performance Analog + Digital Integrated Receiver Decoder (IRD) (MRX4000 PLUS), components, and capabilities.

Here are the topics covered:

Topic	Page
System Descriptions	2-1
MRX4000 PLUS Description	2-1
MRX4000 PLUS Configuration Options	2-2
Configuration Descriptions	2-2
Power Options	2-5
Mounting and Deployment Options	2-5
System Operation	2-5
MRX4000 PLUS Configurations	2-6
MPEG/COFDM Digital Configuration	2-6
FMR NTSC/PAL Analog Configuration	2-6
MPEG/COFDM/FMR NTSC/PAL Digital + Analog Configuration	2-6
For More Information	2-6

2.2 System Descriptions

2.2.1 MRX4000 PLUS Description

The MRX4000 PLUS (Figure 2-1) is a highly reliable, flexible, and compact video microwave Electronic News Gathering (ENG)

analog and digital central receiver systems with demodulation and decode functions for fixed installations.

Figure 2-1: MRX4000 PLUS

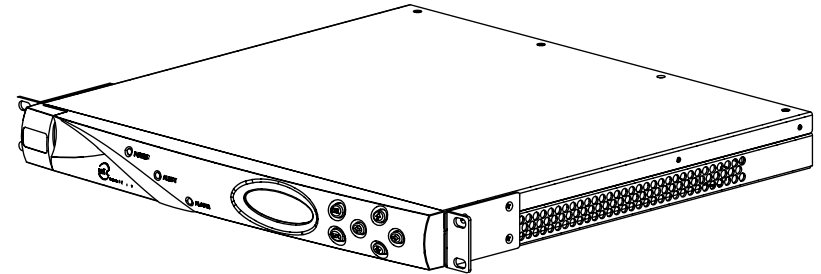

The MRX4000 PLUS is a fully functional, standalone, state of the art ENG central receiver for analog and digital formats and includes the ability to support encapsulated Internet Protocol (IP) packetized service from an ENG or Outside Broadcast (OB) or portable transmitter.

The MRX4000 PLUS is rack-mounted in a standard 19-inch (48.3 cm) rack for fixed site operations.

The MRX4000 PLUS is used in both analog and digital ENG central receive site operations. The unit allows operators to switch between analog and digital operation modes where both applications are used. The MRX4000 PLUS also provides separate video and audio or broadband composite operation.

According to different applications, the MRX4000 PLUS can be factory-configured as a baseband signal Frequency Modulation Receiver (FMR) for analog radio applications, can be configured as a baseband COFDM Demodulator and MPEG Decoder for digital radio applications, or can be configured to include FMR and COFDM/MPEG for both analog and digital radio applications.

Key features of the MRX4000 PLUS are as follows:

- Analog, digital, or analog + digital selectable
- RF/IF receiver with separate control unit techniques
- FMR receiver demodulation technology (analog) with squelch capability
- COFDM demodulation and MPEG decoding technology (digital)
- Digital demodulation for QPSK, 16QAM, and 64QAM
- IF (70 MHz) signal input and monitoring for demodulation
- Four selectable IF bandpass filters for both digital and analog operations
- 900 MHz monitoring from the Low Noise Converter (LNC) for system spectrum monitoring and display
- RF input for microwave radio applications (frequency from 1.99 to 2.5 GHz)
- ASI signal input and output connection interfaces
- SDI signal output connection interfaces
- Video and audio outputs for NTSC or PAL video/audio signal transmission
- Front panel keypad and display operation and control
- Serial and parallel communication interface for remote control and management
- Serial communication interface for remote control and management
- Ethernet I/O interface for system control (Future Option - Not currently active)
- System configuration control and management via the MRX4000 PLUS Configuration Utility software

- Multiple configurations available.

2.2.2 MRX4000 PLUS Configuration Options

The MRX4000 PLUS is currently available in the following configurations:

- MPEG/COFDM/FMR NTSC - Analog + Digital with RF/IF Section
- MPEG/COFDM/FMR PAL - Analog + Digital with RF/IF Section
- FMR NTSC - Analog Only with RF/IF Section
- FMR PAL - Analog Only with RF/IF Section
- MPEG/COFDM - Digital Only with RF/IF Section.

If your MRX4000 PLUS contains the analog FMR module, the module will be factory-configured for either NTSC or PAL operation and cannot be changed by the user. If your MRX4000 PLUS contains the digital MPEG/COFDM modules, no factory or user changes are required to configure the digital modules for NTSC or PAL operation.

MRC is constantly working to expand and upgrade the capabilities of the MRX4000 PLUS. Consult your Sales Representative or contact the factory for the latest information.

2.2.3 Configuration Descriptions

General The front panel of all MRX4000 PLUS configurations (Figure 2-2 on page 2-3) are identical and contain a **POWER** LED, an **ALERT** LED, an **ALARM** LED, an alphanumeric display, and six function switches. The front panel also contains an RS-232 connector, located behind an access cover, to provide interface connections to a Microsoft Windows-based PC.

The rear panels of the various MRX4000 PLUS configurations contain the I/O connectors, the input power connector, the power switch, and power fuses.

Controls, indicators, and connectors contained on all configurations of the MRX4000 PLUS are identified and described in the “Routine Operation” Chapter on page 3-1.

Configurations The rear panels of the MRX4000 PLUS Digital MPEG/COFDM, Analog + Digital MPEG/COFDM/FMR NTSC,

and Digital MPEG/COFDM/FMR PAL configurations are identical and are shown in [Figure 2-3 on page 2-4](#).

The rear panels of the MRX4000 PLUS Analog FMR NTSC and FMR PAL configurations are identical and are shown in [Figure 2-4 on page 2-4](#).

Figure 2-2: MRX4000 PLUS Front Panel View

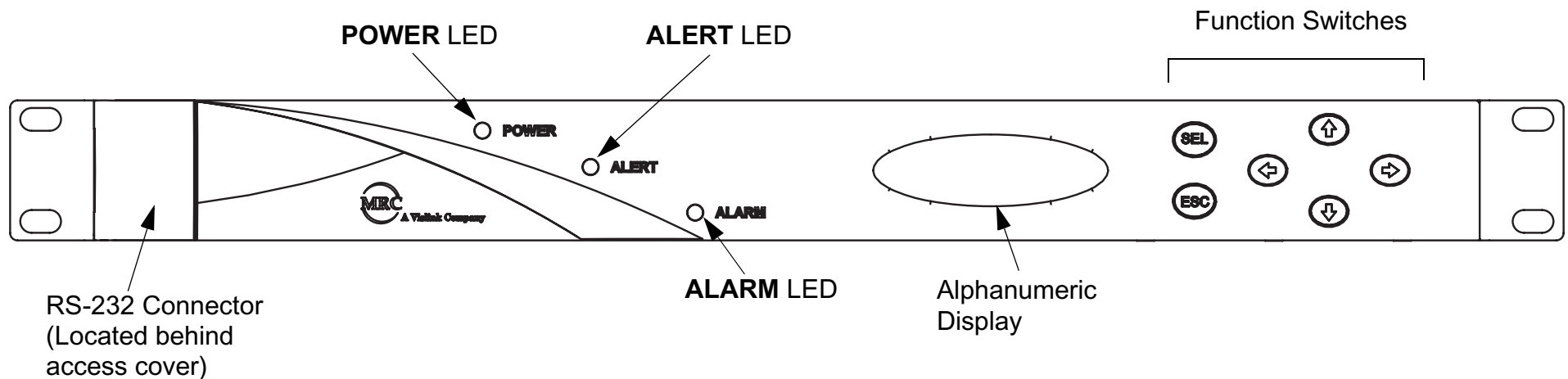
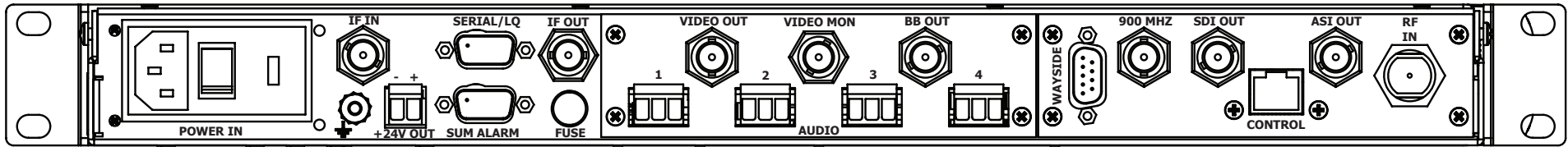
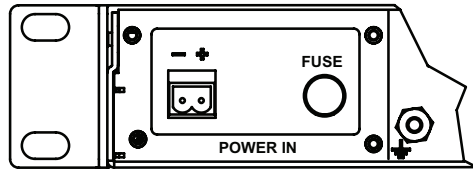

Figure 2-3: MRX4000 PLUS Digital and Analog + Digital Configurations - Rear View



AC Power Option



DC Power Option

Figure 2-4: MRX4000 PLUS Analog Only Configurations - Rear View

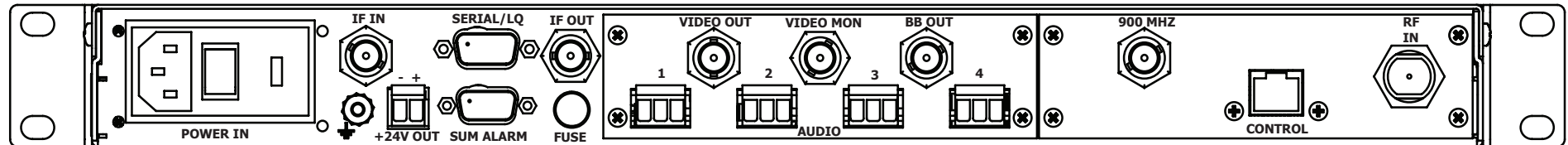

AC Power Option

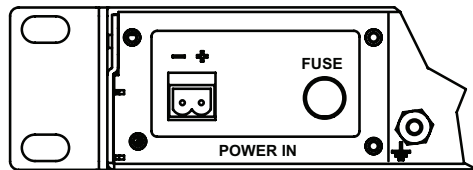

DC Power Option

2.2.4 Power Options

The flexible architecture of the MRX4000 PLUS allows the various configurations to operate on the following AC and DC power sources:

- 120/240 VAC, 50/60 Hz
- +24 or +48 VDC
- -24 or -48 VDC

Fuse ratings for the optional AC and DC power sources are listed in [Table 2-1](#).

Table 2-1: Fuse Ratings

Operating Voltage	Fuse Rating
240 VAC, 50/60 Hz	1.0A, 250V, AGC, Fast Blow
120 VAC, 50/60 Hz	2.0A, 250V, AGC, Fast Blow
48 VDC	5.0A, 250V, 5 x 20 mm
24 VDC	10.0A, 250V, 5 x 20 mm
+24 VDC (Output)	1.0 A, 250V, 5 x 20 mm, Slow Blow

Refer to the [“Installation” Chapter on page 6-1](#) (part of the MRX4000 PLUS Technical Reference Manual only) for additional information.

2.2.5 Mounting and Deployment Options

The MRX4000 PLUS is mounted in a standard 19-inch (48.3 cm) rack for fixed site operations.

For more details on installation of the MRX4000 PLUS in various applications, see the [“Installation” Chapter on page 6-1](#) (part of the MRX4000 PLUS Technical Reference Manual only).

2.2.6 System Operation

The MRX4000 PLUS offers two levels of system operation, designed to match the needs of different personnel.

For the field operator, the MRX4000 PLUS has up to 9 Presets that can be selected from the front panel. Each Preset controls key parameters such as modulation, frequency, and audio and video settings. Additional front panel-controlled settings are dependent upon the configuration options contained in your MRX4000 PLUS. See [“Using the MRX4000 PLUS Screens” on page 3-8](#) for additional information.

For the advanced operator and technical staff, the **MRX4000 PLUS Configuration Utility** (Configurator) software allows complete control of all parameters in your MRX4000 PLUS. The Configurator software runs on a Microsoft Windows-based PC and connects to the MRX4000 PLUS front panel RS-232 connector via an RS-232 serial interface cable.

Interfacing a PC to the MRX4000 PLUS in a connected system gives you complete control of the unit. You can read the current settings, program new settings, or return the unit to its factory default settings. The Configurator software automatically detects what hardware is installed in the system and applies the appropriate configuration, regardless of the hardware being configured.

2.3 MRX4000 PLUS Configurations

MRX4000 PLUS configuration block diagrams are provided in the following sections.

For details on connections between the MRX4000 PLUS and receiver components, refer to the “Installation” Chapter on page 6-1 (part of the MRX4000 PLUS Technical Reference Manual only).

2.3.1 MPEG/COFDM Digital Configuration

The MRX4000 PLUS MPEG/COFDM Digital configuration block diagram is shown in Figure 2-5 on page 2-7.

2.3.2 FMR NTSC/PAL Analog Configuration

The MRX4000 PLUS FMR NTSC/PAL Analog Configuration Block Diagram is shown in Figure 2-6 on page 2-8.

2.3.3 MPEG/COFDM/FMR NTSC/PAL Digital + Analog Configuration

The MRX4000 PLUS MPEG/COFDM/FMR NTSC/PAL Analog + Digital Configuration Block Diagram is shown in Figure 2-7 on page 2-9.

2.4 For More Information

Additional detailed technical information about the MRX4000 PLUS is contained in the MRX4000 PLUS Technical Reference Manual. Specific topics contained in the MRX4000 PLUS Technical Reference Manual are listed below:

Topic	Chapter
Changing settings using the Configuration Utility software	See “Advanced Operation” on page 5-1
Installation	See “Installation” on page 6-1
Connections to other equipment	See “Installation” on page 6-1
Supported Repairs	See “Repair” on page 7-1
Repair Parts	See “Replacement Parts” on page 8-1
Block Diagram	See “Theory of Operation” on page 9-1

Figure 2-5: MRX4000 PLUS MPEG/COFDM Digital Configuration Block Diagram

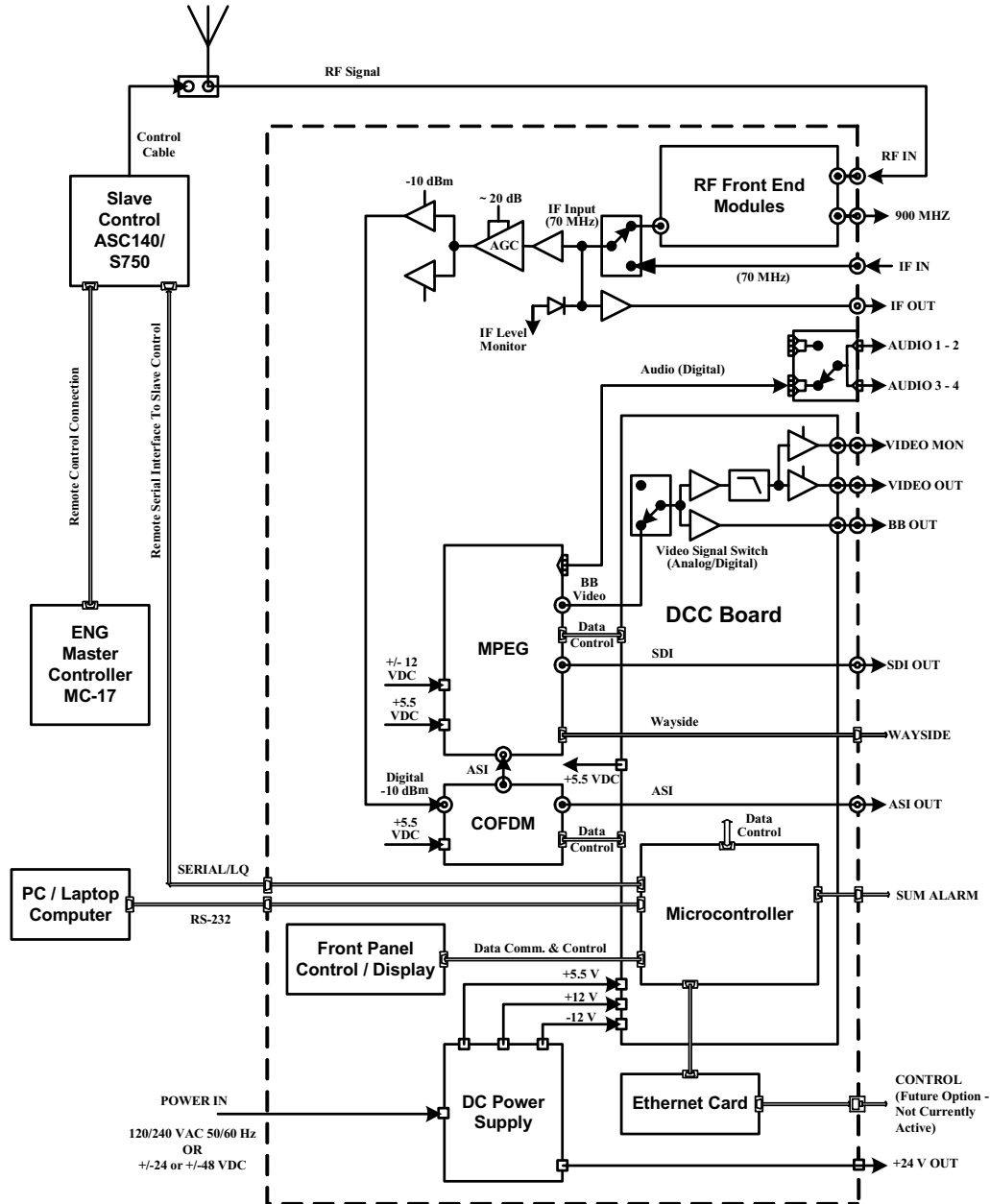

Figure 2-6: MRX4000 PLUS FMR NTSC/PAL Analog Configuration Block Diagram

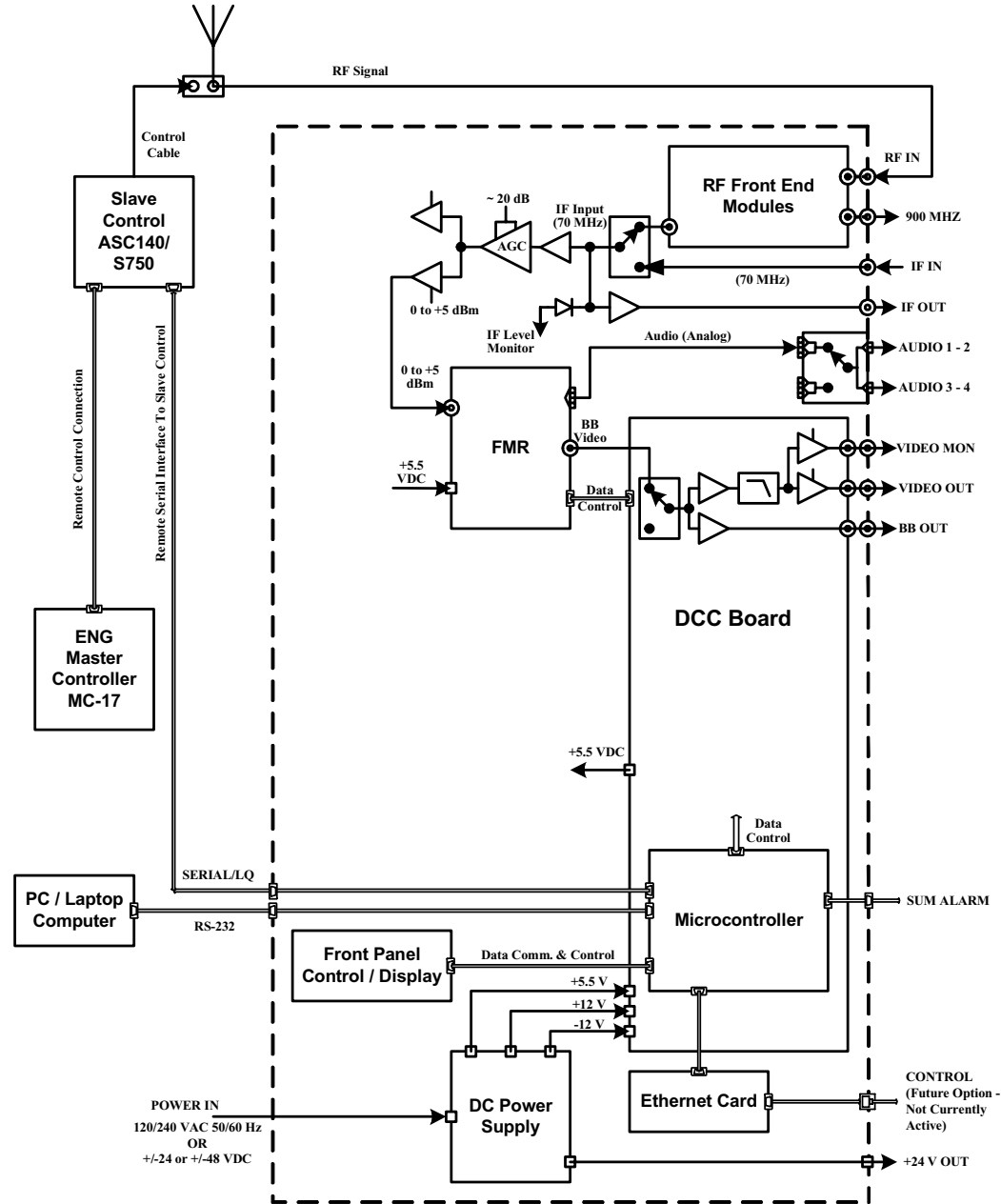
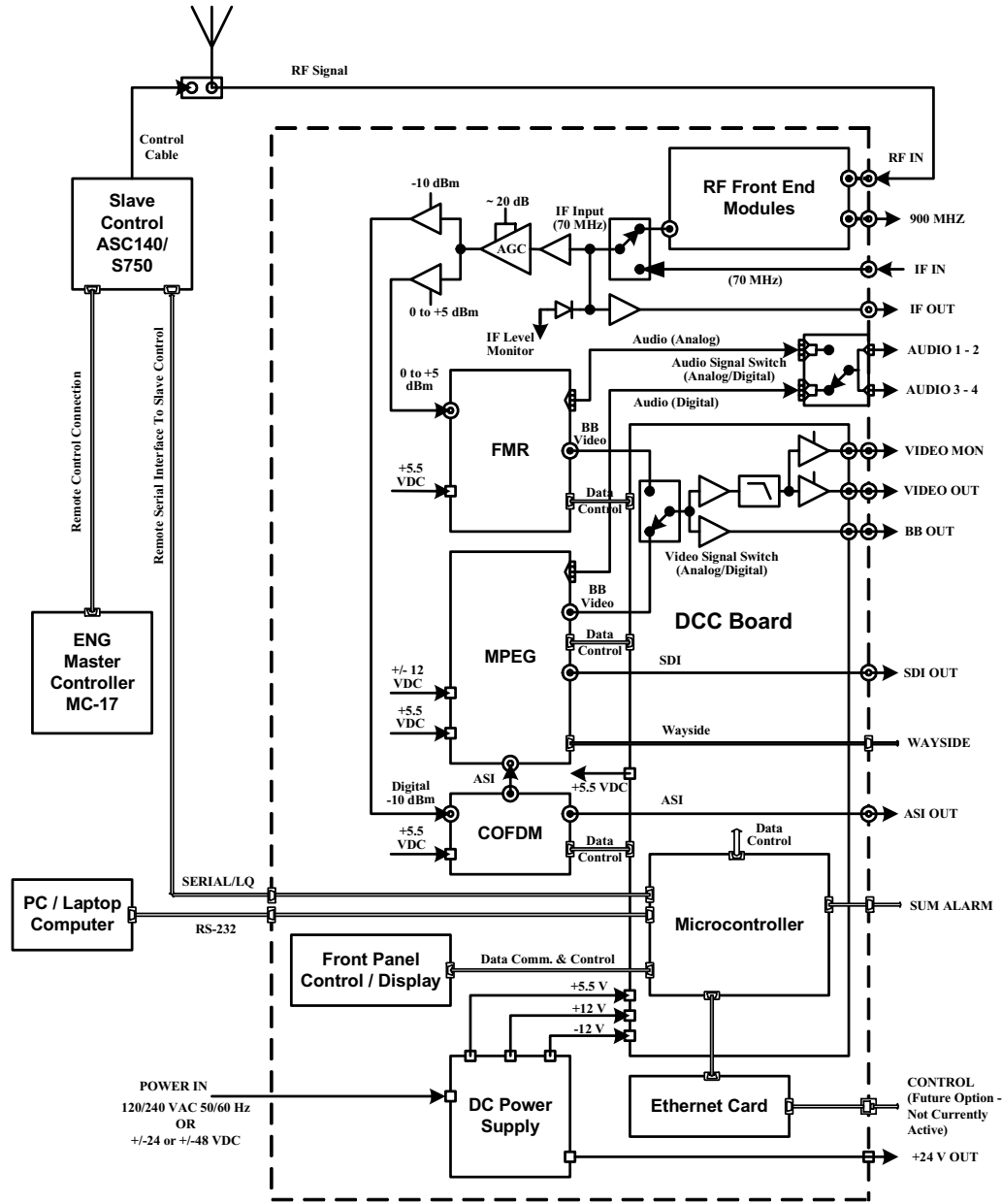

Figure 2-7: MRX4000 PLUS MPEG/COFDM/FMR NTSC/PAL Digital + Analog Configuration Block Diagram



This page intentionally left blank.

3 Routine Operation

3.1 Chapter Overview

This chapter provides basic information that will enable you to operate your MRX4000 PLUS High Performance Analog + Digital Integrated Receiver Decoder (IRD) (MRX4000 PLUS).

Here are the topics covered:

Topic	Page
Overview of Controls, Indicators and Connectors	3-1
Controls and Indicators	3-1
MRX4000 PLUS Digital and Digital + Analog Configuration Connectors	3-3
MRX4000 PLUS Analog Configuration Connectors	3-5
Preparing for Operation	3-7
Fixed or Mobile Installation	3-7
Powering the MRX4000 PLUS	3-7
Using the MRX4000 PLUS Screens	3-8
Overview	3-8
Menu Configurations	3-11
Main Screen	3-11
Cursors	3-11
Accessing Menus	3-13
Monitoring Operations	3-13
Monitor/Change MPEG Settings	3-13
Monitor/Change COFDM Settings	3-28
Monitor/Change FMR Settings	3-37

Monitor/Change MRX4000 PLUS RF/IF Section Settings	3-48
Monitor/Change System Menu Options	3-65
Front Panel vs. Configurator Software	3-71

Information on settings made with the **MRX4000 PLUS Configuration Utility** (Configurator) software can be found in the “[Advanced Operation](#)” Chapter on page 5-1 (part of the MRX4000 PLUS Technical Reference Manual only).

See “[Front Panel vs. Configurator Software](#)” on page 3-71 for a summary of settings that can be made with the front panel control switches and which settings can be made using the Configurator software.

3.2 Overview of Controls, Indicators and Connectors

This section describes the controls, indicators, and connectors contained on the MRX4000 PLUS.

3.2.1 Controls and Indicators

Controls and indicators contained on the MRX4000 PLUS are identified and described below. Topics covered are as follows:

Topic	Page
Rear Panel Input Power Assembly and Fuse	3-2
POWER LED	3-2
ALERT LED	3-2
ALARM LED	3-2
Alphanumeric Display	3-2
Keypad Switches	3-2

Each of the controls and indicators are described in more detail in the following paragraphs. Controls and indicators contained on all configurations of the MRX4000 PLUS are identical and are identified in Figure 3-1.

Rear Panel Input Power Assembly and Fuse The power switch (AC power option only) is used to control application of power to the MRX4000 PLUS. The DC power option does not contain a power switch. The input power assembly also contains the input power fuse and the AC/DC power connector.

POWER LED The green **POWER** LED is illuminated when power is applied to the unit and the power switch (AC power option only) is set to on (I).

ALERT LED The amber **ALERT** LED will illuminate when system errors are present that do not cause the system to lose service.

ALARM LED The red **ALARM** LED will illuminate when system errors are present that cause the system to lose service.

Alphanumeric Display The alphanumeric display provides the user interface to enable local control of the MRX4000 PLUS and to provide full monitoring capability for the system. Additional control of the system is achieved using the Microsoft Windows PC-based Configurator software.

Keypad Switches The keypad switches provide user inputs to control the menu system that appears on the alphanumeric display. Four directional arrow keys, a **SEL** (Select) key, and an **ESC** (Escape) key are used to navigate the MRX4000 PLUS menus and to modify the MRX4000 PLUS settings.

Figure 3-1: MRX4000 PLUS Controls and Indicators

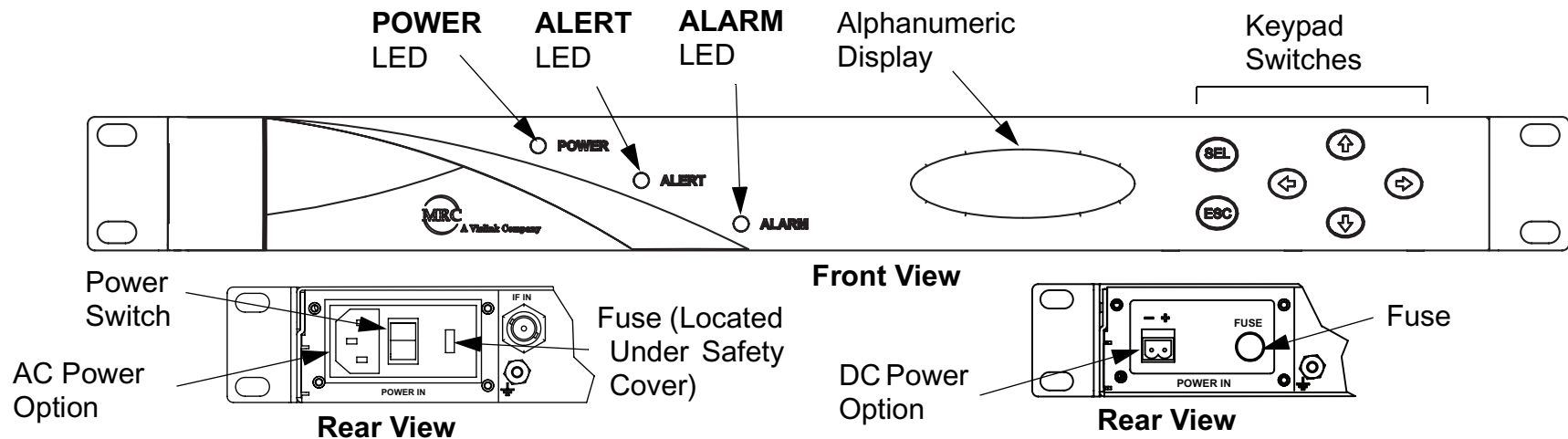

3.2.2 MRX4000 PLUS Digital and Digital + Analog Configuration Connectors

Connectors contained on the Digital MRX4000 PLUS MPEG/COFDM, Digital + Analog MPEG/COFDM/FMR NTSC, and MPEG/COFDM/FMR PAL configurations are identical. These connectors are identified in [Figure 3-2 on page 3-4](#) and are described below. Connectors covered are as follows:

Topic	Page
Front Panel RS-232 Connector	3-3
AC Power Connector with Fuse	3-3
DC Power Connector with Fuse	3-3
IF IN Connector	3-3
SERIAL/LQ Connector	3-3
IF OUT Connector	3-3
VIDEO OUT Connector	3-3
VIDEO MON Connector	3-4
BB OUT Connector	3-4
SDI OUT Connector	3-5
900 MHZ Connector	3-4
WAYSIDE Connector	3-4
ASI OUT Connector	3-5
RF IN Connector	3-5
+24V OUT Connector	3-5
SUM ALARM Connector	3-5
FUSE	3-5
AUDIO 1 thru 4 Connectors	3-5
CONTROL Connector	3-5

Front Panel RS-232 Connector The RS-232 DB-9 male connector, used to provide the interface between the MRX4000 PLUS and a Microsoft Windows-based PC when using the Configurator software, is located behind an access cover on the front panel. This connector is present on all configurations of the MRX4000 PLUS.

The MRX4000 PLUS is configured through the RS-232 connector using the Microsoft Windows PC-based Configurator software. For details, see the [“Advanced Operation” Chapter on page 5-1](#) (part of the MRX4000 PLUS Technical Reference Manual only).

AC Power Connector with Fuse In the AC option, the AC power connector provides connection to the removable external power cable.

The AC power connector also contains an AC input power fuse.

DC Power Connector with Fuse In the DC option, the DC power connector provides connection to the removable external power cable.

The DC power connector also contains a DC input power fuse.

IF IN Connector The **IF IN** 75 ohm BNC female connector provides the input connection for 70 MHz IF to the unit.

SERIAL/LQ Connector The **SERIAL L/Q** 9-pin female D-connector provides remote serial control and also provides DC voltages to monitor Link Quality (LQ) in the digital mode, or Received Carrier Level (RCL) in the analog mode.

IF OUT Connector The **IF OUT** 75 ohm BNC female connector provides the 70 MHz IF output signal.

VIDEO OUT Connector The **VIDEO OUT** 75 ohm BNC female connector provides buffered video output selected either from the FMR or MPEG modules. The video output is also routed via

a video low pass filter (LPF) to remove audio subcarriers or through a bypass filter for other applications.

VIDEO MON Connector The **VIDEO MON** 75 ohm BNC female connector provides buffered video output selected either from the FMR or MPEG modules. The video output is also routed via a video low pass filter (LPF) to remove audio subcarriers or through a bypass filter for other applications or for monitoring purposes.

BB OUT Connector The **BB OUT** 75 ohm BNC female connector provides baseband output unfiltered buffered video

from the FMR or MPEG modules for processing of audio subcarriers.

WAYSIDE Connector The **WAYSIDE** 9-pin female D-connector provides connection to MPEG decoder Wayside output data.

900 MHZ Connector The **900 MHZ** 75 ohm BNC female connector provides a spectrum analyzer output from the MRX4000 PLUS for monitoring on a Troll Remote Control System.

Figure 3-2: MRX4000 PLUS Digital and Digital + Analog Configuration Connectors

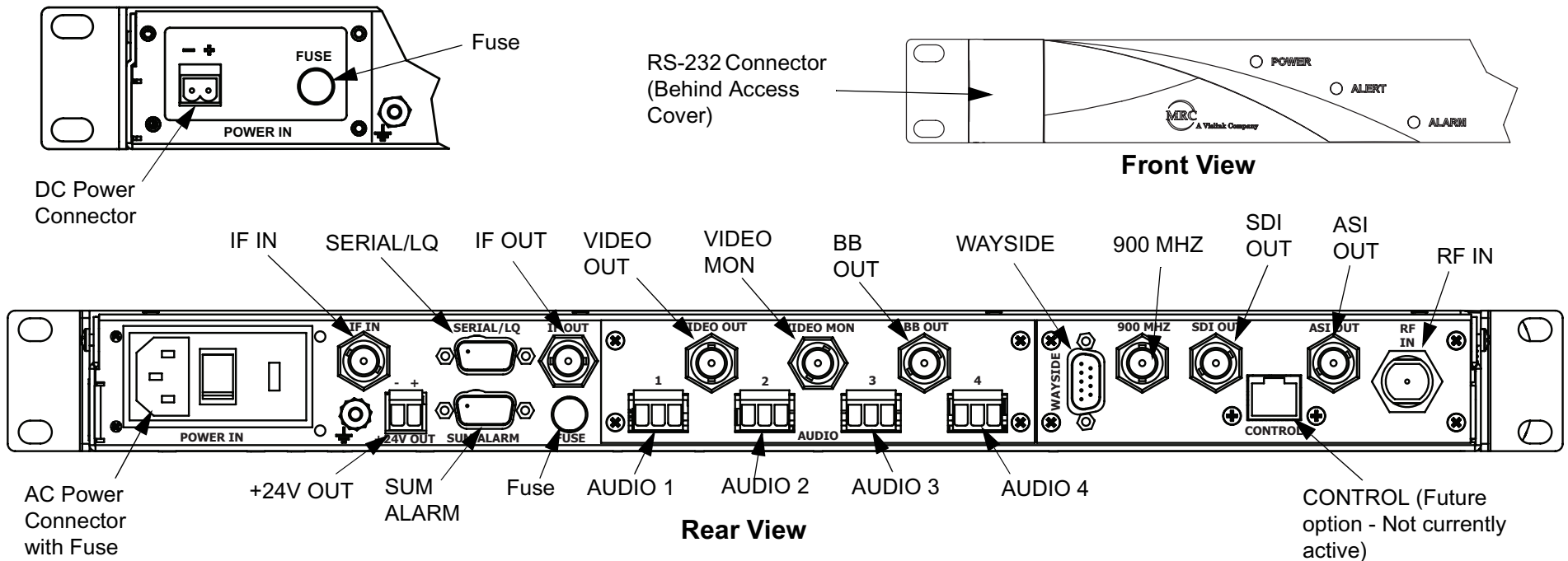

SDI OUT Connector The **SDI OUT** 75 ohm BNC female connector provides SDI output from the MPEG module.

ASI OUT Connector The **ASI OUT** 75 ohm BNC female connector provides ASI output from the COFDM module.

RF IN Connector The type “N” **RF IN** connector provides the RF input from a remote antenna to the MRX4000 PLUS internal Low Noise Converter.

+24V OUT Connector The **+24V OUT** 2-pin connector provides constant (fused) +24 VDC output power for external LNB applications.

SUM ALARM Connector The **SUM ALARM** 9-pin female D-connector provides summary alarm data for common faults and events.

FUSE The fuse provides protection for +24 VDC output power for external LNB applications.

AUDIO 1 thru 4 Connectors The **AUDIO 1 thru 4** 3-pin output connectors provide analog/digital switchable stereo audio signal outputs from the FMR or MPEG modules.

CONTROL Connector The **CONTROL** RJ-45 connector provides I/O connections for system control. (Future option - Not currently active.)

3.2.3 MRX4000 PLUS Analog Configuration Connectors

Connectors contained on the MRX4000 PLUS Analog FMR NTSC and PAL configurations are identical. These connectors are identified in [Figure 3-3 on page 3-6](#) and are described below. Connectors covered are as follows:

Topic	Page
Front Panel RS-232 Connector	3-5

AC Power Connector with Fuse	3-5
DC Power Connector with Fuse	3-6
IF IN Connector	3-6
SERIAL/LQ Connector	3-6
IF OUT Connector	3-6
VIDEO OUT Connector	3-6
VIDEO MON Connector	3-6
BB OUT Connector	3-6
900 MHZ OUT Connector	3-6
RF IN Connector	3-7
+24V OUT Connector	3-7
SUM ALARM Connector	3-7
Fuse	3-7
AUDIO 1 thru 4 Connectors	3-7
CONTROL Connector	3-7

Front Panel RS-232 Connector The RS-232 DB-9 male connector used to provide the interface between the MRX4000 PLUS Demodulator and the Microsoft Windows PC-based Configurator software is located behind an access cover on the front panel. This connector is present on all configurations of the MRX4000 PLUS.

The MRX4000 PLUS is configured through the RS-232 connector using the Microsoft Windows PC-based Configurator software. For details, see the [“Advanced Operation” Chapter on page 5-1](#) (part of the MRX4000 PLUS Technical Reference Manual only).

AC Power Connector with Fuse In the AC option, the AC power connector provides connection to the removable external power cable. The AC power connector also contains an AC input power fuse.

DC Power Connector with Fuse In the DC option, the DC power connector provides connection to the removable external power cable. The DC power connector also contains a DC input power fuse.

IF IN Connector The IF IN 75 ohm BNC female connector provides the input connection for 70 MHz IF to the unit.

SERIAL/LQ Connector The SERIAL L/Q 9-pin female D-connector provides remote serial control and also provides DC voltages to monitor Link Quality (LQ) in the digital mode, or Received Carrier Level (RCL) in the analog mode.

IF OUT Connector The IF OUT 75 ohm BNC female connector provides the 70 MHz IF output signal.

VIDEO OUT Connector The VIDEO OUT 75 ohm BNC female connector provides buffered video output selected from the FMR

module. The video output is also routed via a video low pass filter (LPF) to remove audio subcarriers or through a bypass filter for other applications.

VIDEO MON Connector The VIDEO MON 75 ohm BNC female connector provides buffered video output selected from the FMR module. The video output is also routed via a video low pass filter (LPF) to remove audio subcarriers or through a bypass filter for other applications or for monitoring purposes.

BB OUT Connector The BB OUT 75 ohm BNC female connector provides baseband output unfiltered buffered video from the FMR module for processing of audio subcarriers.

900 MHZ OUT Connector The 900 MHZ 75 ohm BNC female connector provides a spectrum analyzer output for monitoring on a Troll Remote Control System.

Figure 3-3: MRX4000 PLUS Analog Configuration Connectors

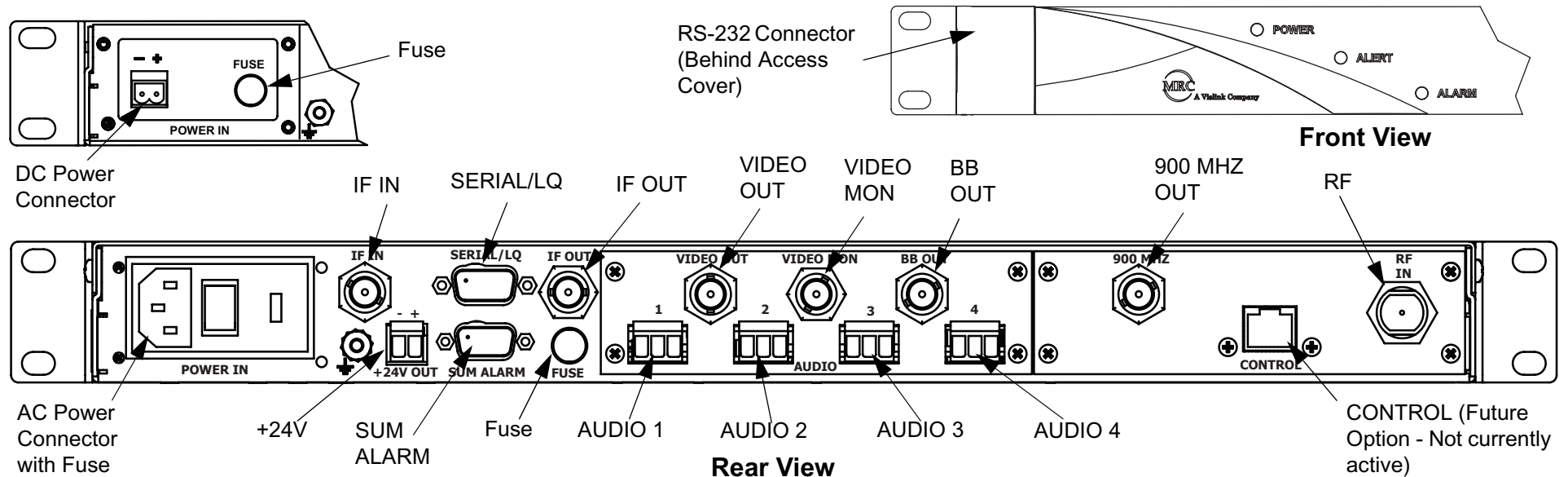

RF IN Connector The type “N” **RF IN** connector provides the RF input from a remote antenna to the MRX4000 PLUS internal Low Noise Converter.

+24V OUT Connector The **+24V OUT** 2-pin connector provides constant (fused) +24 VDC output power for external LNB applications.

SUM ALARM Connector The **SUM ALARM** 9-pin female D-connector provides summary alarm data for common faults and events.

Fuse The fuse provides protection for +24 VDC output power for external LNB applications.

AUDIO 1 thru 4 Connectors The **AUDIO 1 thru 4** 3-pin output connectors provide analog/digital switchable stereo audio signal outputs from the FMR module.

CONTROL Connector The **CONTROL** RJ-45 connector provides Ethernet I/O connections for system control. (Future option - Not currently active.)

3.3 Preparing for Operation

Each installation or deployment will have its own specific tasks according to the application and the installed hardware.

3.3.1 Fixed or Mobile Installation

For fixed installations, the MRX4000 PLUS is mounted in a standard 19-inch (48.3 cm) rack. The cabling is permanently installed and power comes from the facility or site power source.

For mobile applications, the MRX4000 PLUS is usually mounted in a bulkhead or compartment in a 19-inch (48.3 cm) rack. The cabling is permanently installed and power comes from the mobile power source.

3.3.2 Powering the MRX4000 PLUS

The steps required to power up and power down your MRX4000 PLUS are contained in the following steps.

Power Up

1. Verify the power cable is properly connected to the rear panel power connector.
2. Verify all coaxial cables and cable connectors are properly connected to the rear panel connectors.
3. Connect the MRX4000 PLUS power cable to AC or DC power of the correct type, voltage and polarity, as applicable to the power option contained on your unit.

If you are unsure of the power requirements or connections, refer to the “[Installation](#)” chapter (part of the MRX4000 PLUS Technical Reference Manual only).

4. Verify the power source is turned on.
5. Set the MRX4000 PLUS rear panel power switch (AC power option only) to on (I).
6. After approximately a 10 second delay following application of power, the normal power-up sequence is as follows:
 - The front panel green **POWER** LED should illuminate .
 - The alphanumeric display will illuminate and the Main screen ([Figure 3-4 on page 3-8](#)) will be displayed.

Figure 3-4: Main Screen - Typical

```
----- MRX4000+ -----  
>> MPEG Settings  
    COFDM Settings  
    FMR Settings
```

Power Down

1. Set the MRX4000 PLUS rear panel power switch (AC power option only) to off (**O**).
2. Set the power source off, as required.

3.4 Using the MRX4000 PLUS Screens

Once the MRX4000 PLUS is set up using the Configurator software and is powered up, you will be able to monitor and/or change certain operating parameters through the use of the menus displayed on the front panel alphanumeric display.

All options are dependent upon the actual configuration of your MRX4000 PLUS and the Preset Operation Mode settings established using the Configurator software. See "Advanced Operation" on page 5-1 for additional information on use of the Configurator software (part of MRX4000 PLUS Technical Reference Manual only).

The sections listed in [Table 3-1](#) describe use of the menus.

Table 3-1: Using MRX4000 PLUS Menus

Topic	Page
Overview	3-8
Menu Configurations	3-11
Main Screen	3-11
Cursors	3-11
Accessing Menus	3-13

3.4.1 Overview

As you use the MRX4000 PLUS, you will interact extensively with the menus. The front panel alphanumeric display and function keys provide you with the means to view and/or modify operational parameters of the MRX4000 PLUS via use of the menu pages displayed on the alphanumeric display.

The menu pages are organized in a hierarchy. The top level menu is displayed upon power up of the unit and is returned to, by default, when the user interface times out in approximately 30 seconds.

Menus will only display a maximum of three options. If a menu contains more than three options, it will be necessary to scroll through the options using the Up and Down arrow function keys.

The following are some points to make this easier.

The Main screen is your starting point for navigating through the various menus. The Main screen provides access to the current values of the Preset selected and the selected Preset options.

When power is applied to the MRX4000 PLUS, the Main screen will be displayed. See [Figure 3-5 on page 3-9](#).

Figure 3-5: Main Screen - Typical

```
----- MRX4000+ -----  
>> MPEG Settings  
    COFDM Settings  
    FMR Settings
```

The top level menu hierarchy is illustrated in [Figure 3-6 on page 3-10](#). From the top level menu page, the user descends into the lower levels of the menu hierarchy until the operational parameter required is reached.

Notes	If your MRX4000 PLUS does not contain an MPEG, COFDM, RF/IF, or FMR module, or the Preset operation mode selected does not include MPEG, COFDM, RF/IF, or FMR, the >> cursor will be replaced by a * cursor when the option is selected. Attempts to access those options will be ignored by the firmware.
--------------	---

Illustrations reflecting individual menu hierarchy and the associated options are listed in [Table 3-2](#).

Table 3-2: Menu Hierarchy

Figure	Page
MPEG Decoder Menu Map - Typical	3-15
COFDM Menu Map	3-29
FMR Settings Menu Map	3-38

Table 3-2: Menu Hierarchy (Continued)

Figure	Page
MRX4000 PLUS RF/IF Settings Menu Map	3-49
System Menu Map	3-66

Each menu page has multiple selections available, with one selection per line. Once the user has navigated to the menu page required, the user can observe or change an operating parameter, as required. To observe or change a parameter, different cursors are displayed ([See "Cursors" on page 3-11](#)), indicating different options available to the user.

The selections available on any menu page can exceed the number of lines physically displayed. The front panel firmware creates a box that surrounds the complete set of lines on any menu page.

As the user scrolls through the set of menu item lines using the Up and Down arrow keys, the firmware also moves the surrounding box graphics to indicate to the user that options are available that are off the alphanumeric display, i.e., either above or below what is currently displayed ([See "Accessing Menus" on page 3-13](#)).

Figure 3-6: Top Level Main Menu Hierarchy - Typical

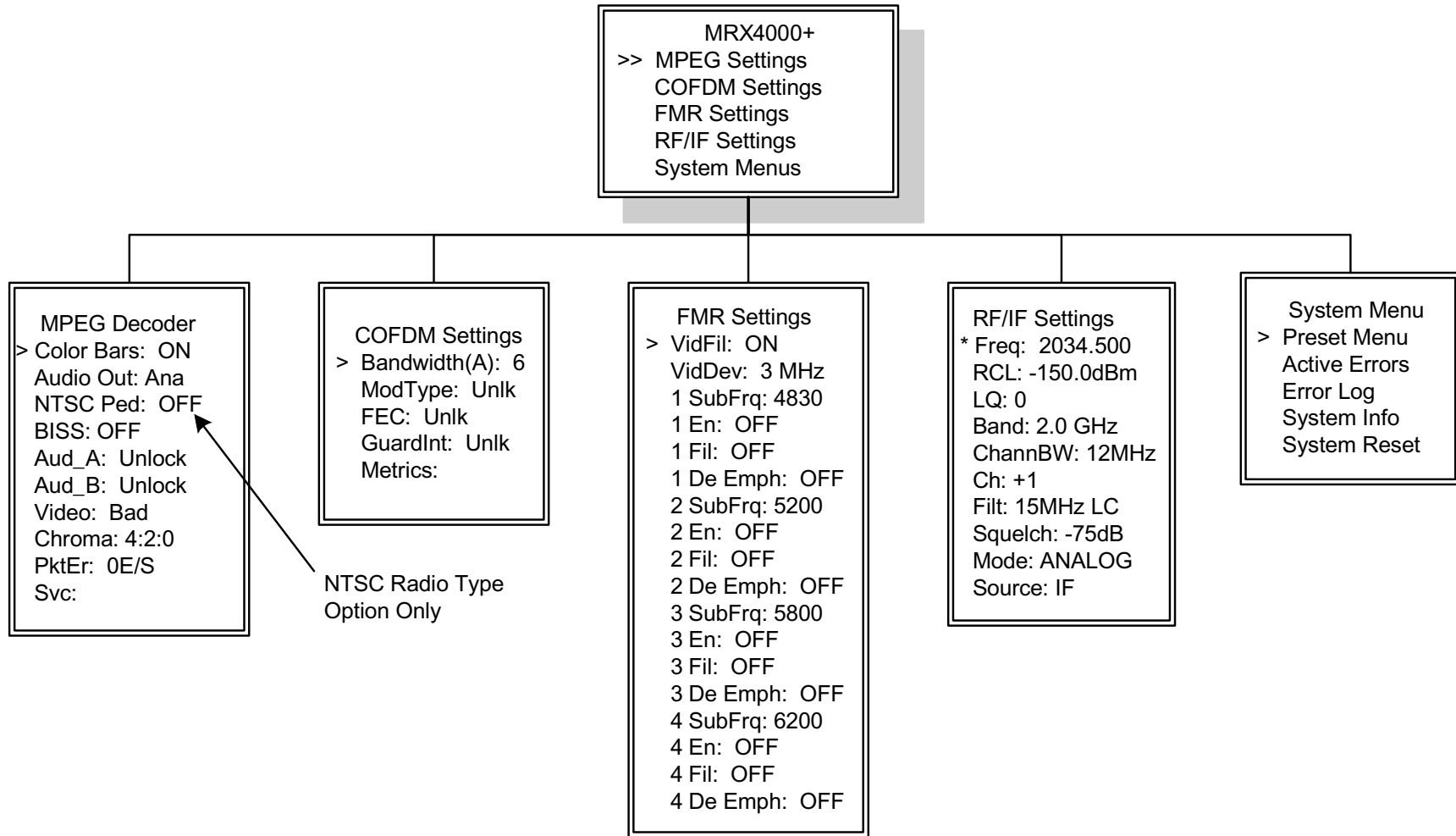

3.4.2 Menu Configurations

The firmware determines which modules are contained in your MRX4000 PLUS configuration upon power-up. The menus show only those selections that are relevant to the user, based on the current hardware configuration and Configurator software settings.

Only options that are meaningful to the current chassis configuration are displayed. In other words, if an optional module is not contained in the MRX4000 PLUS, either the entire menu page is not available or individual lines on a given menu page are not available.

Additionally, if the Configurator software Preset operation mode selected does not include MPEG, COFDM, RF/IF, or FMR, attempts to access those options will be ignored by the system.

3.4.3 Main Screen

The Main screen is your starting point for navigating through the various menus. The Main screen provides access to the current values of the Preset selected and the selected Preset options.

When power is applied to the MRX4000 PLUS, the Main screen, as shown in [Figure 3-7](#), will be displayed.

Figure 3-7: MRX4000 PLUS Main Screen - Typical

```
----- MRX4000+ -----  
>> MPEG Settings  
    COFDM Settings  
    FMR Settings
```

3.4.4 Cursors

The menu options will display several different cursors which will change as various menu options are selected. The cursors are identified as follows:

- The >> cursor, displayed to the left of a menu option, indicates the option contains a sub-menu when selected. Selecting that option, using the arrow keys and/or **SEL** key, will bring you to the sub-menu.

For example, selecting >> **MPEG Settings** from the Main screen menu, as shown in [Figure 3-8](#), will bring you to the **MPEG Decoder** sub-menu options, as shown in [Figure 3-9](#).

Figure 3-8: Main Screen Menu - Typical

```
----- MRX4000+ -----  
>> MPEG Settings  
    COFDM Settings  
    FMR Settings
```

Figure 3-9: MPEG Decoder Menu Options - Typical

```
----- MPEG Decoder -----  
> Color Bars:  ON  
    Audio Out: Ana  
    NTSC Ped:  OFF
```

Notes	If your MRX4000 PLUS does not contain an MPEG, COFDM, RF/IF, or FMR module, or the Preset operation mode selected does not include MPEG, COFDM, RF/IF, or FMR, the >> cursor will be replaced by a * cursor when the option is selected.
--------------	--

Attempts to access those options will be ignored by the firmware.

- The **>** cursor indicates the menu item selected contains options that can be changed using the arrow keys and the **SEL** key.
- The **!** cursor will be displayed when a **>** menu option is selected for change. It will also be displayed while the arrow keys are being used to make option selections.

After pressing the **SEL** key to select the option or value, the **!** cursor will change back to a **>** cursor after approximately 7 seconds.

If no arrow keys are pressed within approximately 7 seconds, the **!** cursor will change back to a **>** cursor, and the original option or value will be displayed. The **SEL** key must be pressed to store any changes when the **!** cursor is displayed.

- The ***** cursor will be displayed for menu items that are read-only indications, for items that are currently inactive, or for options that are not installed in the chassis.

When the ***** cursor is displayed, the item selected may only be changed using the Configurator software or by the factory.

If you press the **SEL** key when the ***** cursor is displayed, the **display will become locked on that screen** to allow you to observe status changes, i.e., to allow you to monitor packet errors, etc. Pressing the **ESC** key unlocks the display and returns you to the Main screen.

Changing Operating Parameters When the cursor is on an operational parameter menu line that the user wishes to change, and the **SEL** or Right arrow key is pressed, the cursor will change and the firmware will enter the edit mode.

If the operating parameter requires values from a list of values, the Up and Down keys provide the means to move through the list of possible values. If the values are numeric, the Up, Down, Left, and Right arrow keys provide the means to move through the values in large or small steps.

The Up and Down keys move the values in larger steps, while the Left and Right keys move the values in smaller steps. All operational parameters have associated value ranges, defined by upper and lower value limits.

There are two types of numeric values displayed: integers and decimal. For example, if the operational parameter is a Preset number, the keys allow selection of the Preset using the Preset selection number.

When the correct value is located, the **SEL** key is pressed and the value is recorded by the firmware and communicated to the modules in the chassis. Further, the edit mode is exited and the cursor changes from the **!** cursor to the **>** cursor.

Menu Option Selections When making menu option selections, the last option selected on the alphanumeric display will be displayed when that menu is again accessed, unless power has been removed from the unit.

When moving from menu to menu, it may be necessary to use the arrow keys to move up and down through the menu options to reach the option required.

Return to the Main Screen You can access the Main screen at any time by pressing the **ESC** key until the Main screen is displayed.

Default to Main Screen If you do not press the menu control keys (**SEL**, **ESC**, or Left, Right, Up, or Down arrow keys) for approximately 30 seconds, the display will automatically default to the Main screen.

3.4.5 Accessing Menus

The option menus are accessed using the front panel **SEL** key and/or the Left, Right, Up, and Down arrow keys.

To select the option required, press the Up or Down arrow keys to move the cursor (>>) to the option required and press either the **SEL** key or the Right arrow key. A typical Main screen menu showing selection of the >> **MPEG Settings** option is shown in [Figure 3-10](#) and a typical **MPEG Decoder** menu is shown in [Figure 3-11](#).

Figure 3-10: Menu Options

```

----- MRX4000+ -----
>> MPEG Settings
    COFDM Settings
    FMR Settings
  
```

Figure 3-11: MPEG Decoder Menu Options

```

----- MPEG Decoder-----
> Color Bars: ON
    Audio Out: Ana
    NTSC Ped: OFF
  
```

Menus will display a maximum of three options. If the menus are not as shown in [Figure 3-10](#) or [Figure 3-11](#), press the Up arrow key until the option required is displayed.

For example, the Main screen menu also contains a **System Menus** option that will be displayed by moving the cursor (>>) down using the Down arrow key. [See Figure 3-12](#).

Figure 3-12: Modulator Menu Additional Option

```

----- MRX4000+ -----
    FMR Settings
    >> System Menus
  
```

See [“Monitoring Operations”](#) to access individual Main screen menu options .

3.5 Monitoring Operations

Once the MRX4000 PLUS is set up using the Configurator software and is powered up, you will be able to check its configuration and monitor its operation.

The following sections describe how to use the menus and how to monitor the quality of the microwave link.

Here are the tasks described:

Topic	Page
Monitor/Change MPEG Settings	3-13
Monitor/Change COFDM Settings	3-28
Monitor/Change FMR Settings	3-37
Monitor/Change MRX4000 PLUS RF/IF Section Settings	3-48
Monitor/Change System Menu Options	3-65

3.6 Monitor/Change MPEG Settings

If your MRX4000 PLUS configuration contains an MPEG Decoder, the procedures listed in [Table 3-3 on page 3-14](#) are used to monitor or change internal MPEG Decoder parameters or settings.

Table 3-3: Monitor/Change MPEG Settings

Topic	Page	Monitor Only	Change
Monitor/Change Color Bars	3-16		✓
Monitor/Change Audio Output Mode Setting	3-17		✓
Monitor/Change NTSC Pedestal	3-18		✓
Monitor/Change BISS Settings	3-20		✓
Monitor Audio A	3-21	✓	
Monitor Audio B	3-23	✓	
Monitor Video Status	3-24	✓	
Monitor Chroma Status	3-25	✓	
Monitor Service Name	3-26	✓	

See Figure 3-13 on page 3-15 for the MPEG Decoder Menu Map.

Figure 3-13: MPEG Decoder Menu Map - Typical

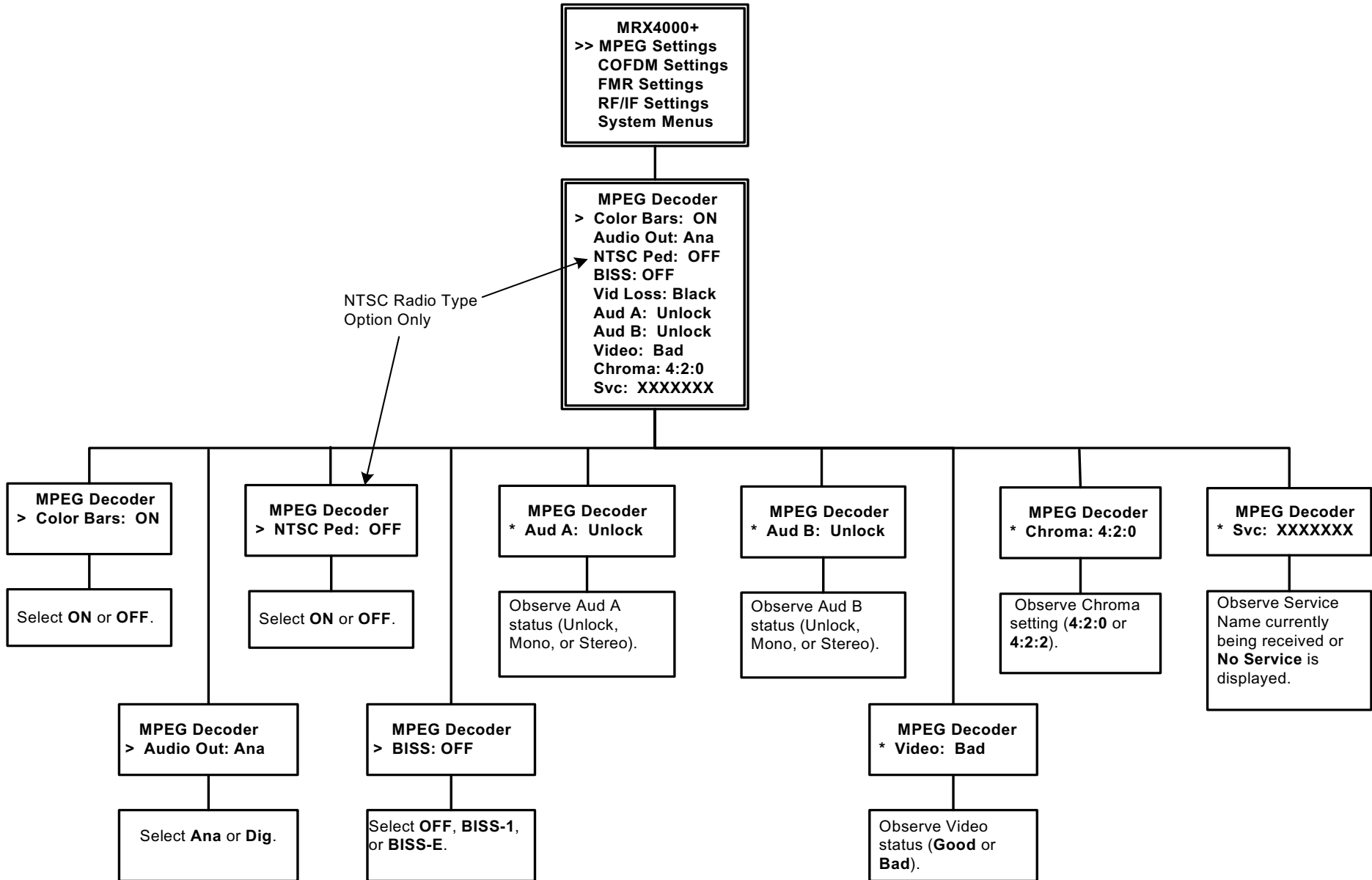

Notes Prior to monitoring or making any changes to the MRX4000 PLUS MPEG Settings, you must determine which Preset or Presets have been set for the IF IN MPEG or RF IN MPEG operation mode using the Configurator software.

The Preset operation modes should have been recorded when the MRX4000 PLUS was programmed using the Configurator software.

3.6.1 Monitor/Change Color Bars

To monitor/change **Color Bars** option settings, perform the following steps:

1. Verify the MRX4000 PLUS is powered up.
2. Verify the Main screen (Figure 3-14) is displayed. If the Main screen is not displayed, press the **ESC** key until the Main screen is displayed.

Figure 3-14: Main Screen Menu

```
----- MRX4000+ -----
>> MPEG Settings
    COFDM Settings
    FMR Settings
```

3. Press the Up arrow key, as required, to move the cursor to the **MPEG Settings** option.

Note If the cursor adjacent to the **MPEG Settings** option is an asterisk (*), go to [step 4](#); if the cursor adjacent to the **MPEG Settings** option is a >>, go to [step 13](#).

4. Press the Down arrow key to move the cursor to the Main screen **System Menu** option and press the **SEL** key.
5. Observe the **System Menu** (Figure 3-15) is displayed.

Figure 3-15: System Menu

```
--- System Menu ---
>> Preset Menu
    Active Errors
    Error Log
```

6. Press the Up or Down arrow keys, as required, to select the >> **Preset Menu** option.
7. Observe the **Preset Menu** (Figure 3-16) is displayed.

Figure 3-16: Preset Menu - Typical

```
--- Preset Menu ---
* #1:Preset 1
    Save Settings
    Recall Preset
```

8. Press the Up or Down arrow keys, as required, to select the > **Recall Preset** option.
9. Press the **SEL** key or Right arrow key and observe the > cursor changes to a ! cursor.
10. Press the Up, Down, Right, or Left arrow keys, as required, to select the Preset programmed for the IF

- IN MPEG or RF IN MPEG operation mode and press the **SEL** key.
11. Press the **ESC** key until the Main screen is displayed.
 12. Press the Up arrow key, as required, to select the **MPEG Settings** option.

Notes In the following step, if the cursor adjacent to the **MPEG Settings** option is not a >> cursor, the wrong Preset has been selected for the IF IN MPEG or RF IN MPEG operation mode.

Repeat from [step 4](#) to select the correct Preset.

13. Verify the cursor adjacent to the **MPEG Settings** option is a >> cursor.
14. Press the **SEL** key or the Right arrow key and observe the **MPEG Decoder** menu ([Figure 3-17](#)) is displayed.

Figure 3-17: MPEG Decoder Menu - Typical

```

  --- MPEG Decoder ---
  > Color Bars:  ON
      Audio Out: Ana
      NTSC Ped:  OFF
  
```

15. Press the Up or Down arrow keys, as required, to select the > **Color Bars:** option.
16. Press the Right arrow or **SEL** key and observe the > cursor adjacent to the **Color Bars:** option changes to a ! cursor.
17. Press the Right, Left, Up, or Down arrow keys, as required, to select **ON** or **OFF**.

18. Press the **SEL** key and observe the ! cursor changes to a > cursor.
19. Press the **ESC** key until the Main screen is displayed.

3.6.2 Monitor/Change Audio Output Mode Setting

To monitor/change the audio output mode (**Audio Out:**) setting, perform the following steps:

1. Verify the MRX4000 PLUS is powered up.
2. Verify the Main screen ([Figure 3-18](#)) is displayed. If the Main screen is not displayed, press the **ESC** key until the Main screen is displayed.

Figure 3-18: Main Screen Menu

```

  --- MRX4000+ ---
  >> MPEG Settings
      COFDM Settings
      FMR Settings
  
```

3. Press the Up arrow key, as required, to move the cursor to the **MPEG Settings** option.

Note If the cursor adjacent to the **MPEG Settings** option is an asterisk (*), go to [step 4](#); if the cursor adjacent to the **MPEG Settings** option is a >>, go to [step 13](#).

4. Press the Down arrow key to move the cursor to the Main screen **System Menus** option and press the **SEL** key.
5. Observe the **System Menu** ([Figure 3-19 on page 3-18](#)) is displayed.

Figure 3-19: System Menu

```
--- System Menu ---  
>> Preset Menu  
    Active Errors  
    Error Log
```

6. Press the Up or Down arrow keys, as required, to select the **>> Preset Menu** option.
7. Observe the **Preset Menu** (Figure 3-20) is displayed.

Figure 3-20: Preset Menu - Typical

```
--- Preset Menu ---  
* #1:Preset 1  
    Save Settings  
    Recall Preset
```

8. Press the Up or Down arrow keys, as required, to select the **> Recall Preset** option.
9. Press the **SEL** key or Right arrow key and observe the **>** cursor changes to a **!** cursor.
10. Press the Up, Down, Right, or Left arrow keys, as required, to select the Preset programmed for the IF IN MPEG or RF IN MPEG operation mode and press the **SEL** key.
11. Press the **ESC** key until the Main screen is displayed.
12. Press the Up arrow key, as required, to select the **MPEG Settings** option.

Notes In the following step, if the cursor adjacent to the **MPEG Settings** option is not a **>>** cursor, the wrong Preset has been selected for the IF IN MPEG or RF IN MPEG operation mode.

Repeat from [step 4](#) to select the correct Preset.

13. Verify the cursor adjacent to the **MPEG Settings** option is a **>>** cursor.
14. Press the **SEL** key or the Right arrow key and observe the **MPEG Decoder** menu (Figure 3-21) is displayed.

Figure 3-21: MPEG Decoder Menu - Typical

```
--- MPEG Decoder ---  
> Color Bars: ON  
    Audio Out: Ana  
    NTSC Ped: OFF
```

15. Press the Up or Down arrow keys, as required, to select the **> Audio Out:** option.
16. Press the Right arrow or **SEL** key and observe the **>** cursor adjacent to the **Audio Out:** option changes to a **!** cursor.
17. Press the Right, Left, Up, or Down arrow keys, as required, to select **Ana** or **Dig**.
18. Press the **SEL** key and observe the **!** cursor changes to a **>** cursor.
19. Press the **ESC** key until the Main screen is displayed.

3.6.3 Monitor/Change NTSC Pedestal

To monitor/change NTSC Pedestal option settings on an NTSC configuration MRX4000 PLUS only, perform the following steps:

1. Verify the MRX4000 PLUS is powered up.
2. Verify the Main screen (Figure 3-22) is displayed. If the Main screen is not displayed, press the **ESC** key until the Main screen is displayed.

Figure 3-22: Main Screen Menu

```

----- MRX4000+ -----
  >> MPEG Settings
      COFDM Settings
      FMR Settings
  
```

3. Press the Up arrow key, as required, to move the cursor to the **MPEG Settings** option.

Note If the cursor adjacent to the **MPEG Settings** option is an asterisk (*), go to [step 4](#); if the cursor adjacent to the **MPEG Settings** option is a >>, go to [step 13](#).

4. Press the Down arrow key to move the cursor to the Main screen **System Menus** option and press the **SEL** key.
5. Observe the **System Menu** (Figure 3-23) is displayed.

Figure 3-23: System Menu

```

--- System Menu ---
  >> Preset Menu
      Active Errors
      Error Log
  
```

6. Press the Up or Down arrow keys, as required, to select the >> **Preset Menu** option.

7. Observe the **Preset Menu** (Figure 3-24) is displayed.

Figure 3-24: Preset Menu - Typical

```

--- Preset Menu ---
  * #1:Preset 1
      Save Settings
      Recall Preset
  
```

8. Press the Up or Down arrow keys, as required, to select the > **Recall Preset** option.
9. Press the **SEL** key or Right arrow key and observe the > cursor changes to a ! cursor.
10. Press the Up, Down, Right, or Left arrow keys, as required, to select the Preset programmed for the IF IN MPEG or RF IN MPEG operation mode and press the **SEL** key.
11. Press the **ESC** key until the Main screen is displayed.
12. Press the Up arrow key, as required, to select the **MPEG Settings** option.

Notes In the following step, if the cursor adjacent to the **MPEG Settings** option is not a >> cursor, the wrong Preset has been selected for the IF IN MPEG or RF IN MPEG operation mode.

Repeat from [step 4](#) to select the correct Preset.

13. Verify the cursor adjacent to the **MPEG Settings** option is a >> cursor.
14. Press the **SEL** key or the Right arrow key and observe the **MPEG Decoder** menu (Figure 3-25 on page 3-20) is displayed.

Figure 3-25: MPEG Decoder Menu - Typical

```
----- MPEG Decoder -----  
> Color Bars: ON  
  Audio Out: Ana  
  NTSC Ped: OFF
```

15. Press the Up or Down arrow keys, as required, to select the **> NTSC Ped:** option.
16. Press the Right arrow or **SEL** key and observe the **>** cursor adjacent to the **NTSC Ped:** option changes to a **!** cursor.
17. Press the Right, Left, Up, or Down arrow keys, as required, to select **ON** or **OFF**.
18. Press the **SEL** key and observe the **!** cursor changes to a **>** cursor.
19. Press the **ESC** key until the Main screen is displayed.

3.6.4 Monitor/Change BISS Settings

To monitor/change **BISS** settings, perform the following steps:

Notes Basic Interoperable Scrambling System (BISS) is a factory-configured option that must be ordered when you order your MRX4000 PLUS. You must have the BISS option enabled to perform the following steps.

The BISS operating mode and associated encryption key(s) must be programmed into the MRX4000 PLUS using the Configurator software before the following steps can be performed.

1. Verify the MRX4000 PLUS is powered up.
2. Verify the Main screen ([Figure 3-26](#)) is displayed. If the Main screen is not displayed, press the **ESC** key until the Main screen is displayed.

Figure 3-26: Main Screen Menu

```
----- MRX4000+ -----  
>> MPEG Settings  
  COFDM Settings  
  FMR Settings
```

3. Press the Up arrow key, as required, to move the cursor to the **MPEG Settings** option.

Note If the cursor adjacent to the **MPEG Settings** option is an asterisk (*), go to [step 4](#); if the cursor adjacent to the **MPEG Settings** option is a **>>**, go to [step 13](#).

4. Press the Down arrow key to move the cursor to the Main screen **System Menus** option and press the **SEL** key.
5. Observe the **System Menu** ([Figure 3-27](#)) is displayed.

Figure 3-27: System Menu

```
--- System Menu ---  
>> Preset Menu  
  Active Errors  
  Error Log
```

6. Press the Up or Down arrow keys, as required, to select the **>> Preset Menu** option.

- Observe the **Preset Menu** (Figure 3-28) is displayed.

Figure 3-28: Preset Menu - Typical

```

--- Preset Menu ---
* #1:Preset 1
  Save Settings
  Recall Preset
  
```

- Press the Up or Down arrow keys, as required, to select the **> Recall Preset** option.
- Press the **SEL** key or Right arrow key and observe the **>** cursor changes to a **!** cursor.
- Press the Up, Down, Right, or Left arrow keys, as required, to select the Preset programmed for the IF IN MPEG or RF IN MPEG operation mode and press the **SEL** key.
- Press the **ESC** key until the Main screen is displayed.
- Press the Up arrow key, as required, to select the **MPEG Settings** option.

Notes In the following step, if the cursor adjacent to the **MPEG Settings** option is not a **>>** cursor, the wrong Preset has been selected for the IF IN MPEG or RF IN MPEG operation mode.

Repeat from [step 4](#) to select the correct Preset.

- Verify the cursor adjacent to the **MPEG Settings** option is a **>>** cursor.
- Press the **SEL** key or the Right arrow key and observe the **MPEG Decoder** menu is displayed. [See Figure 3-29.](#)

Figure 3-29: MPEG Decoder Menu - Typical

```

--- MPEG Decoder ---
> Color Bars: ON
  Audio Out: Ana
  NTSC Ped: OFF
  
```

- Press the Up or Down arrow keys, as required, to select the **> BISS:** option.
- Press the Right arrow or **SEL** key and observe the **>** cursor adjacent to the **BISS:** option changes to a **!** cursor.
- Press the Right, Left, Up, or Down arrow keys, as required, to select **OFF**, **BISS-1**, or **BISS-E**.
- Press the **SEL** key and observe the **!** cursor changes to a **>** cursor.
- Press the **ESC** key until the Main screen is displayed.

3.6.5 Monitor Audio A

To monitor Audio A (**Aud A**) status, perform the following steps:

- Verify the MRX4000 PLUS is powered up.
- Verify the Main screen ([Figure 3-30](#)) is displayed. If the Main screen is not displayed, press the **ESC** key until the Main screen is displayed.

Figure 3-30: Main Screen Menu

```

--- MRX4000+ ---
>> MPEG Settings
  COFDM Settings
  FMR Settings
  
```

3. Press the Up arrow key, as required, to move the cursor to the **MPEG Settings** option.

Note If the cursor adjacent to the **MPEG Settings** option is an asterisk (*), go to [step 4](#); if the cursor adjacent to the **MPEG Settings** option is a >>, go to [step 13](#).

4. Press the Down arrow key to move the cursor to the Main screen **System Menu** option and press the **SEL** key.
5. Observe the **System Menu** ([Figure 3-31](#)) is displayed.

Figure 3-31: System Menu

```

--- System Menu ---
>> Preset Menu
    Active Errors
    Error Log
  
```

6. Press the Up or Down arrow keys, as required, to select the >> **Preset Menu** option.
7. Observe the **Preset Menu** ([Figure 3-32](#)) is displayed.

Figure 3-32: Preset Menu - Typical

```

--- Preset Menu ---
* #1:Preset 1
    Save Settings
    Recall Preset
  
```

8. Press the Up or Down arrow keys, as required, to select the > **Recall Preset** option.

9. Press the **SEL** key or Right arrow key and observe the > cursor changes to a ! cursor.
10. Press the Up, Down, Right, or Left arrow keys, as required, to select the Preset programmed for the IF IN MPEG or RF IN MPEG operation mode and press the **SEL** key.
11. Press the **ESC** key until the Main screen is displayed.
12. Press the Up arrow key, as required, to select the **MPEG Settings** option.

Notes In the following step, if the cursor adjacent to the **MPEG Settings** option is not a >> cursor, the wrong Preset has been selected for the IF IN MPEG or RF IN MPEG operation mode.

Repeat from [step 4](#) to select the correct Preset.

13. Verify the cursor adjacent to the **MPEG Settings** option is a >> cursor.
14. Press the **SEL** key or the Right arrow key and observe the **MPEG Decoder** menu ([Figure 3-33](#)) is displayed.

Figure 3-33: MPEG Decoder Menu - Typical

```

[--- MPEG Decoder---]
| > Color Bars:  ON  |
| Audio Out:  Ana  |
| NTSC Ped:   OFF  |
  
```

15. Press the Up or Down arrow keys, as required, to select the * **Aud_A:** option.
16. Observe **Aud_A:** status (**Unlock**, **Mono**, or **Stereo**).
17. Press the **ESC** key until the Main screen is displayed.

3.6.6 Monitor Audio B

To monitor Audio B (**Aud B**) status, perform the following steps:

1. Verify the MRX4000 PLUS is powered up.
2. Verify the Main screen ([Figure 3-34](#)) is displayed. If the Main screen is not displayed, press the **ESC** key until the Main screen is displayed.

Figure 3-34: Main Screen Menu

```
----- MRX4000+ -----  
>> MPEG Settings  
    COFDM Settings  
    FMR Settings
```

3. Press the Up arrow key, as required, to move the cursor to the **MPEG Settings** option.

Note If the cursor adjacent to the **MPEG Settings** option is an asterisk (*), go to [step 4](#); if the cursor adjacent to the **MPEG Settings** option is a >>, go to [step 13](#).

4. Press the Down arrow key to move the cursor to the Main screen **System Menu** option and press the **SEL** key.
5. Observe the **System Menu** is displayed. See [Figure 3-35](#).

Figure 3-35: System Menu

```
----- System Menu -----  
>> Preset Menu  
    Active Errors  
    Error Log
```

6. Press the Up or Down arrow keys, as required, to select the >> **Preset Menu** option.
7. Observe the **Preset Menu** is displayed. See [Figure 3-36](#).

Figure 3-36: Preset Menu - Typical

```
--- Preset Menu ---  
* #1:Preset 1  
  Save Settings  
  Recall Preset
```

8. Press the Up or Down arrow keys, as required, to select the > **Recall Preset** option.
9. Press the **SEL** key or Right arrow key and observe the > cursor changes to a ! cursor.
10. Press the Up, Down, Right, or Left arrow keys, as required, to select the Preset programmed for the IF IN MPEG or RF IN MPEG operation mode and press the **SEL** key.
11. Press the **ESC** key until the Main screen is displayed.
12. Press the Up arrow key, as required, to select the **MPEG Settings** option.

Notes In the following step, if the cursor adjacent to the **MPEG Settings** option is not a >> cursor, the wrong Preset has been selected for the IF IN MPEG or RF IN MPEG operation mode.

Repeat from [step 4](#) to select the correct Preset.

13. Verify the cursor adjacent to the **MPEG Settings** option is a >> cursor.

- Press the **SEL** key or the Right arrow key and observe the **MPEG Decoder** menu (Figure 3-37) is displayed.

Figure 3-37: MPEG Decoder Menu - Typical

```

  --- MPEG Decoder ---
  > Color Bars: ON
    Audio Out: Ana
    NTSC Ped: OFF
  
```

- Press the Up or Down arrow keys, as required, to select the * **Aud_B:** option.
- Observe **Aud_B:** status (**Unlock**, **Mono**, or **Stereo**).
- Press the **ESC** key until the Main screen is displayed.

3.6.7 Monitor Video Status

The procedure required to monitor **Video** status is contained in the following steps.

- Verify the MRX4000 PLUS is powered up.
- Verify the Main screen (Figure 3-38) is displayed. If the Main screen is not displayed, press the **ESC** key until the Main screen is displayed.

Figure 3-38: Main Screen Menu

```

  ----- MRX4000+ -----
  >> MPEG Settings
    COFDM Settings
    FMR Settings
  
```

- Press the Up arrow key, as required, to move the cursor to the **MPEG Settings** option.

Note If the cursor adjacent to the **MPEG Settings** option is an asterisk (*), go to [step 4](#); if the cursor adjacent to the **MPEG Settings** option is a >>, go to [step 13](#).

- Press the Down arrow key to move the cursor to the Main screen **System Menu** option and press the **SEL** key.
- Observe the **System Menu** (Figure 3-39) is displayed.

Figure 3-39: System Menu

```

  --- System Menu ---
  >> Preset Menu
    Active Errors
    Error Log
  
```

- Press the Up or Down arrow keys, as required, to select the >> **Preset Menu** option.
- Observe the **Preset Menu** (Figure 3-40) is displayed.

Figure 3-40: Preset Menu - Typical

```

  --- Preset Menu ---
  * #1:Preset 1
    Save Settings
    Recall Preset
  
```

- Press the Up or Down arrow keys, as required, to select the > **Recall Preset** option.
- Press the **SEL** key or Right arrow key and observe the > cursor changes to a ! cursor.

10. Press the Up, Down, Right, or Left arrow keys, as required, to select the Preset programmed for the IF IN MPEG or RF IN MPEG operation mode and press the **SEL** key.
11. Press the **ESC** key until the Main screen is displayed.
12. Press the Up arrow key, as required, to select the **MPEG Settings** option.

Notes In the following step, if the cursor adjacent to the **MPEG Settings** option is not a >> cursor, the wrong Preset has been selected for the IF IN MPEG or RF IN MPEG operation mode.

Repeat from [step 4](#) to select the correct Preset.

13. Verify the cursor adjacent to the **MPEG Settings** option is a >> cursor.
14. Press the **SEL** key or the Right arrow key and observe the **MPEG Decoder** menu is displayed. [See Figure 3-41](#).

Figure 3-41: MPEG Decoder Menu - Typical

```

  --- MPEG Decoder ---
  > Color Bars: ON
    Audio Out: Ana
    NTSC Ped: OFF
  
```

15. Press the Up or Down arrow keys, as required, to select the * **Video:** option.
16. Observe **Video:** status (**Good** or **Bad**).
17. Press the **ESC** key until the Main screen is displayed.

3.6.8 Monitor Chroma Status

The procedure to monitor **Chroma** status is contained in the following steps:

1. Verify the MRX4000 PLUS is powered up.
2. Verify the Main screen ([Figure 3-42](#)) is displayed. If the Main screen is not displayed, press the **ESC** key until the Main screen is displayed.

Figure 3-42: Main Screen Menu

```

  --- MRX4000+ ---
  >> MPEG Settings
    COFDM Settings
    FMR Settings
  
```

3. Press the Up arrow key, as required, to move the cursor to the **MPEG Settings** option.

Note If the cursor adjacent to the **MPEG Settings** option is an asterisk (*), go to [step 4](#); if the cursor adjacent to the **MPEG Settings** option is a >>, go to [step 13](#).

4. Press the Down arrow key to move the cursor to the Main screen **System Menu** option and press the **SEL** key.
5. Observe the **System Menu** ([Figure 3-43](#)) is displayed.

Figure 3-43: System Menu

```

  --- System Menu ---
  >> Preset Menu
    Active Errors
    Error Log
  
```

6. Press the Up or Down arrow keys, as required, to select the **>> Preset Menu** option.
7. Observe the **Preset Menu** (Figure 3-44) is displayed.

Figure 3-44: Preset Menu - Typical

```

--- Preset Menu ---
* #1:Preset 1
  Save Settings
  Recall Preset
  
```

8. Press the Up or Down arrow keys, as required, to select the **> Recall Preset** option.
9. Press the **SEL** key or Right arrow key and observe the **>** cursor changes to a **!** cursor.
10. Press the Up, Down, Right, or Left arrow keys, as required, to select the Preset programmed for the IF IN MPEG or RF IN MPEG operation mode and press the **SEL** key.
11. Press the **ESC** key until the Main screen is displayed.
12. Press the Up arrow key, as required, to select the **MPEG Settings** option.

14. Press the **SEL** key or the Right arrow key and observe the **MPEG Decoder** menu (Figure 3-45) is displayed.

Figure 3-45: MPEG Decoder Menu - Typical

```

--- MPEG Decoder ---
> Color Bars: ON
  Audio Out: Ana
  NTSC Ped: OFF
  
```

15. Press the Up or Down arrow keys, as required, to select the *** Chroma:** option.
16. Observe **Chroma:** status (**4:2:0** or **4:2:2**).
17. Press the **ESC** key until the Main screen is displayed.

3.6.9 Monitor Service Name

The procedure required to monitor the Service Name (**Svc**) of the Preset is contained in the following steps.

1. Verify the MRX4000 PLUS is powered up.
2. Verify the Main screen (Figure 3-46) is displayed. If the Main screen is not displayed, press the **ESC** key until the Main screen is displayed.

Figure 3-46: Main Screen Menu

```

----- MRX4000+ -----
>> MPEG Settings
  COFDM Settings
  FMR Settings
  
```

13. Verify the cursor adjacent to the **MPEG Settings** option is a **>>** cursor.

3. Press the Up arrow key, as required, to move the cursor to the **MPEG Settings** option.

Notes In the following step, if the cursor adjacent to the **MPEG Settings** option is not a **>>** cursor, the wrong Preset has been selected for the IF IN MPEG or RF IN MPEG operation mode.

Repeat from [step 4](#) to select the correct Preset.

Note If the cursor adjacent to the **MPEG Settings** option is an asterisk (*), go to [step 4](#); if the cursor adjacent to the **MPEG Settings** option is a >>, go to [step 13](#).

4. Press the Down arrow key to move the cursor to the Main screen **System Menu** option and press the **SEL** key.
5. Observe the **System Menu** ([Figure 3-47](#)) is displayed.

Figure 3-47: System Menu

```
--- System Menu ---  
>> Preset Menu  
    Active Errors  
    Error Log
```

6. Press the Up or Down arrow keys, as required, to select the >> **Preset Menu** option.
7. Observe the **Preset Menu** ([Figure 3-48](#)) is displayed.

Figure 3-48: Preset Menu - Typical

```
--- Preset Menu ---  
* #1:Preset 1  
    Save Settings  
    Recall Preset
```

8. Press the Up or Down arrow keys, as required, to select the > **Recall Preset** option.
9. Press the **SEL** key or Right arrow key and observe the > cursor changes to a ! cursor.
10. Press the Up, Down, Right, or Left arrow keys, as required, to select the Preset programmed for the IF

IN MPEG or RF IN MPEG operation mode and press the **SEL** key.

11. Press the **ESC** key until the Main screen is displayed.
12. Press the Up arrow key, as required, to select the **MPEG Settings** option.

Notes In the following step, if the cursor adjacent to the **MPEG Settings** option is not a >> cursor, the wrong Preset has been selected for the IF IN MPEG or RF IN MPEG operation mode.

Repeat from [step 4](#) to select the correct Preset.

13. Verify the cursor adjacent to the **MPEG Settings** option is a >> cursor.
14. Press the **SEL** key or the Right arrow key and observe the **MPEG Decoder** menu ([Figure 3-49](#)) is displayed.

Figure 3-49: MPEG Decoder Menu - Typical

```
--- MPEG Decoder ---  
> Color Bars: ON  
    Audio Out: Ana  
    NTSC Ped: OFF
```

15. Press the Up or Down arrow keys, as required, to select the * **Svc:** option.
16. Observe the selected Preset Service Name is displayed.
17. Press the **ESC** key and observe the Main screen is displayed.

3.7 Monitor/Change COFDM Settings

If your MRX4000 PLUS configuration contains a COFDM option, the procedures listed in [Table 3-4](#) are used to monitor or change internal COFDM parameters or settings.

Table 3-4: Monitor/Change COFDM Settings

Topic	Page	Monitor Only	Change
Monitor/Change Bandwidth	3-30		✓
Monitor Modulator Type	3-31	✓	
Monitor Forward Error Correction	3-32	✓	
Monitor Guard Interval	3-34	✓	
Monitor COFDM Metrics	3-35	✓	

See [Figure 3-50](#) on [page 3-29](#) for the COFDM Menu Map.

Figure 3-50: COFDM Menu Map

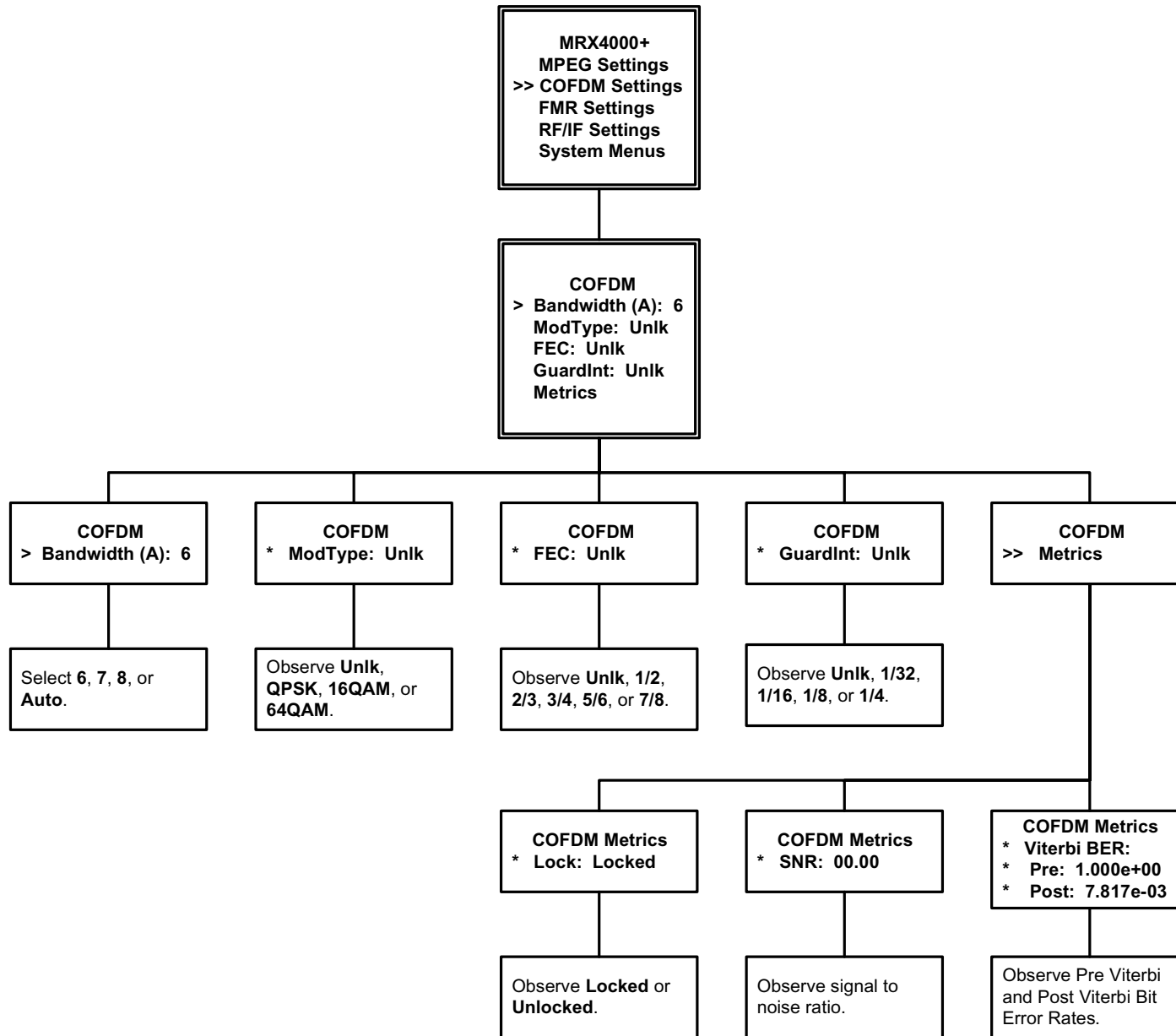

Notes Prior to monitoring or making any changes to the MRX4000 PLUS COFDM Settings, you must determine which Preset or Presets have been set for the IF IN MPEG or RF IN MPEG operation mode using the Configurator software.

The Preset operation modes should have been recorded when the MRX4000 PLUS was programmed using the Configurator software.

3.7.1 Monitor/Change Bandwidth

To monitor/change **Bandwidth**: option settings for the current Preset, perform the following steps:

1. Verify the MRX4000 PLUS is powered up.
2. Verify the Main screen (Figure 3-51) is displayed. If the Main screen is not displayed, press the **ESC** key until the Main screen is displayed.

Figure 3-51: Main Screen Menu

```
----- MRX4000+ -----  
>> MPEG Settings  
    COFDM Settings  
    FMR Settings
```

3. Press the Up or Down arrow keys, as required, to move the cursor to the **COFDM Settings** option.

Note If the cursor adjacent to the **COFDM Settings** option is an asterisk (*), go to [step 4](#); if the cursor adjacent to the **COFDM Settings** option is a >>, go to [step 13](#).

4. Press the Down arrow key to move the cursor to the Main screen **System Menu** option and press the **SEL** key.
5. Observe the **System Menu** (Figure 3-52) is displayed.

Figure 3-52: System Menu

```
--- System Menu ---  
>> Preset Menu  
    Active Errors  
    Error Log
```

6. Press the Up or Down arrow keys, as required, to select the >> **Preset Menu** option.
7. Observe the **Preset Menu** (Figure 3-53) is displayed.

Figure 3-53: Preset Menu - Typical

```
--- Preset Menu ---  
* #1:Preset 1  
    Save Settings  
    Recall Preset
```

8. Press the Up or Down arrow keys, as required, to select the > **Recall Preset** option.
9. Press the **SEL** key or Right arrow key and observe the > cursor changes to a ! cursor.
10. Press the Up, Down, Right, or Left arrow keys, as required, to select the Preset programmed for the IF IN MPEG or RF IN MPEG Operation Mode and press the **SEL** key.
11. Press the **ESC** key until the Main screen is displayed.
12. Press the Up arrow key, as required, to select the **COFDM Settings** option.

Notes In the following step, if the cursor adjacent to the **COFDM Settings** option is not a >> cursor, the wrong Preset has been selected for the IF IN MPEG or RF IN MPEG operation mode.

Repeat from [step 4](#) to select the correct Preset.

13. Verify the cursor adjacent to the **COFDM Settings** option is a >> cursor.
14. Press the **SEL** key or the Right arrow key and observe the **COFDM** menu ([Figure 3-54](#)) is displayed.

Figure 3-54: COFDM Menu - Typical

```
-----COFDM-----  
> Bandwidth (A): 6  
  ModType: Unlk  
  FEC: Unlk
```

15. Press the Up or Down arrow keys, as required, to select the > **Bandwidth (A)**: option.
16. Press the Right arrow or **SEL** key and observe the > cursor adjacent to the **Bandwidth (A)**: option changes to a ! cursor.
17. Press the Right, Left, Up, or Down arrow keys, as required, to select **6**, **7**, **8**, or **Auto**.
18. Press the **SEL** key and observe the ! cursor changes to a > cursor.
19. Press the **ESC** key until the Main screen is displayed.

3.7.2 Monitor Modulator Type

To monitor Modulator Type (**Mod Type**:) option settings for the current Preset, perform the following steps:

1. Verify the MRX4000 PLUS is powered up.
2. Verify the Main screen ([Figure 3-55](#)) is displayed. If the Main screen is not displayed, press the **ESC** key until the Main screen is displayed.

Figure 3-55: Main Screen Menu

```
-----MRX4000+-----  
>> MPEG Settings  
    COFDM Settings  
    FMR Settings
```

3. Press the Up or Down arrow keys, as required, to move the cursor to the **COFDM Settings** option.

Note If the cursor adjacent to the **COFDM Settings** option is an asterisk (*), go to [step 4](#); if the cursor adjacent to the **COFDM Settings** option is a >>, go to [step 13](#).

4. Press the Down arrow key to move the cursor to the Main screen **System Menus** option and press the **SEL** key.
5. Observe the **System Menu** is displayed. [See Figure 3-56](#).

Figure 3-56: System Menu

```
--- System Menu ---  
>> Preset Menu  
    Active Errors  
    Error Log
```

6. Press the Up or Down arrow keys, as required, to select the **>> Preset Menu** option.
7. Observe the **Preset Menu** (Figure 3-57) is displayed.

Figure 3-57: Preset Menu - Typical

```

---- Preset Menu ----
* #1:Preset 1
  Save Settings
  Recall Preset
  
```

8. Press the Up or Down arrow keys, as required, to select the **> Recall Preset** option.
9. Press the **SEL** key or Right arrow key and observe the **>** cursor changes to a **!** cursor.
10. Press the Up, Down, Right, or Left arrow keys, as required, to select the Preset programmed for the IF IN MPEG or RF IN MPEG operation mode and press the **SEL** key.
11. Press the **ESC** key until the Main screen is displayed.
12. Press the Up arrow key, as required, to select the **COFDM Settings** option.

Figure 3-58: COFDM Menu - Typical

```

----- COFDM -----
> Bandwidth (A): 6
  ModType: Unlk
  FEC: Unlk
  
```

15. Press the Up or Down arrow keys, as required, to select the *** ModType:** option.
16. Observe **ModType:** indicates **Unlk, QPSK, 16QAM,** or **64QAM.**
17. Press the **ESC** key until the Main screen is displayed.

3.7.3 Monitor Forward Error Correction

The procedure required to monitor Forward Error Correction (FEC) is contained in the following steps.

1. Verify the MRX4000 PLUS is powered up.
2. Verify the Main screen (Figure 3-59) is displayed. If the Main screen is not displayed, press the **ESC** key until the Main screen is displayed.

Figure 3-59: Main Screen Menu

```

----- MRX4000+ -----
>> MPEG Settings
  COFDM Settings
  FMR Settings
  
```

3. Press the Up or Down arrow keys, as required, to move the cursor to the **COFDM Settings** option.

Notes In the following step, if the cursor adjacent to the **COFDM Settings** option is not a **>>** cursor, the wrong Preset has been selected for the IF IN MPEG or RF IN MPEG operation mode.

Repeat from [step 4](#) to select the correct Preset.

13. Verify the cursor adjacent to the **COFDM Settings** option is a **>>** cursor.
14. Press the **SEL** key or the Right arrow key and observe the **COFDM** menu (Figure 3-58) is displayed.

Note If the cursor adjacent to the **COFDM Settings** option is an asterisk (*), go to [step 4](#); if the cursor adjacent to the **COFDM Settings** option is a >>, go to [step 13](#).

4. Press the Down arrow key to move the cursor to the Main screen **System Menu** option and press the **SEL** key.
5. Observe the **System Menu** ([Figure 3-60](#)) is displayed.

Figure 3-60: System Menu

```
--- System Menu ---  
>> Preset Menu  
    Active Errors  
    Error Log
```

6. Press the Up or Down arrow keys, as required, to select the >> **Preset Menu** option.
7. Observe the **Preset Menu** ([Figure 3-61](#)) is displayed.

Figure 3-61: Preset Menu - Typical

```
--- Preset Menu ---  
* #1:Preset 1  
    Save Settings  
    Recall Preset
```

8. Press the Up or Down arrow keys, as required, to select the > **Recall Preset** option.
9. Press the **SEL** key or Right arrow key and observe the > cursor changes to a ! cursor.

10. Press the Up, Down, Right, or Left arrow keys, as required, to select the Preset programmed for the IF IN MPEG or RF IN MPEG operation mode and press the **SEL** key.
11. Press the **ESC** key until the Main screen is displayed.
12. Press the Up arrow key, as required, to select the **COFDM Settings** option.

Notes In the following step, if the cursor adjacent to the **COFDM Settings** option is not a >> cursor, the wrong Preset has been selected for the IF IN MPEG or RF IN MPEG operation mode.

Repeat from [step 4](#) to select the correct Preset.

13. Verify the cursor adjacent to the **COFDM Settings** option is a >> cursor.
14. Press the **SEL** key or the Right arrow key and observe the **COFDM** menu ([Figure 3-62](#)) is displayed.

Figure 3-62: COFDM Menu - Typical

```
-----COFDM-----  
> Bandwidth (A): 6  
    ModType: Unlk  
    FEC: Unlk
```

15. Press the Up or Down arrow keys, as required, to select the * **FEC:** option.
16. Observe **FEC:** indicates **Unlk, 1/2, 3/4, 5/6, or 7/8**.
17. Press the **ESC** key until the Main screen is displayed.

3.7.4 Monitor Guard Interval

The procedure required to monitor Guard Interval (**GuardInt**) status is contained in the following steps.

1. Verify the MRX4000 PLUS is powered up.
2. Verify the Main screen ([Figure 3-63](#)) is displayed. If the Main screen is not displayed, press the **ESC** key until the Main screen is displayed.

Figure 3-63: Main Screen Menu

```
----- MRX4000+ -----  
>> MPEG Settings  
    COFDM Settings  
    FMR Settings
```

3. Press the Up or Down arrow keys, as required, to move the cursor to the **COFDM Settings** option.

Note If the cursor adjacent to the **COFDM Settings** option is an asterisk (*), go to [step 4](#); if the cursor adjacent to the **COFDM Settings** option is a >>, go to [step 13](#).

4. Press the Down arrow key to move the cursor to the Main screen **System Menu** option and press the **SEL** key.
5. Observe the **System Menu** ([Figure 3-64](#)) is displayed.

Figure 3-64: System Menu

```
--- System Menu ---  
>> Preset Menu  
    Active Errors  
    Error Log
```

6. Press the Up or Down arrow keys, as required, to select the **>> Preset Menu** option.
7. Observe the **Preset Menu** ([Figure 3-65](#)) is displayed.

Figure 3-65: Preset Menu - Typical

```
--- Preset Menu ---  
* #1:Preset 1  
    Save Settings  
    Recall Preset
```

8. Press the Up or Down arrow keys, as required, to select the **> Recall Preset** option.
9. Press the **SEL** key or Right arrow key and observe the **>** cursor changes to a **!** cursor.
10. Press the Up, Down, Right, or Left arrow keys, as required, to select the Preset programmed for the IF IN MPEG or RF IN MPEG operation mode and press the **SEL** key.
11. Press the **ESC** key until the Main screen is displayed.
12. Press the Up arrow key, as required, to select the **COFDM Settings** option.

Notes In the following step, if the cursor adjacent to the **COFDM Settings** option is not a >> cursor, the wrong Preset has been selected for the IF IN MPEG or RF IN MPEG operation mode.

Repeat from [step 4](#) to select the correct Preset.

13. Verify the cursor adjacent to the **COFDM Settings** option is a >> cursor.

- Press the **SEL** key or the Right arrow key and observe the **COFDM** menu (Figure 3-66) is displayed.

Figure 3-66: COFDM Menu - Typical

```

-----COFDM-----
> Bandwidth (A): 6
  ModType: Unlk
  FEC: Unlk
  
```

- Press the Up or Down arrow keys, as required, to select the * **GuardInt**: option.
- Observe **GuardInt**: indicates **Unlk**, **1/32**, **1/16**, **1/8**, or **1/4**.
- Press the **ESC** key until the Main screen is displayed.

3.7.5 Monitor COFDM Metrics

The procedure required to monitor COFDM Metrics is contained in the following steps.

- Verify the MRX4000 PLUS is powered up.
- Verify the Main screen (Figure 3-67) is displayed. If the Main screen is not displayed, press the **ESC** key until the Main screen is displayed.

Figure 3-67: Main Screen Menu

```

-----MRX4000+-----
>> MPEG Settings
   COFDM Settings
   FMR Settings
  
```

- Press the Up or Down arrow keys, as required, to move the cursor to the **COFDM Settings** option.

Note If the cursor adjacent to the **COFDM Settings** option is an asterisk (*), go to [step 4](#); if the cursor adjacent to the **COFDM Settings** option is a >>, go to [step 13](#).

- Press the Down arrow key to move the cursor to the Main screen **System Menu** option and press the **SEL** key.
- Observe the **System Menu** (Figure 3-68) is displayed.

Figure 3-68: System Menu

```

--- System Menu ---
>> Preset Menu
   Active Errors
   Error Log
  
```

- Press the Up or Down arrow keys, as required, to select the >> **Preset Menu** option.
- Observe the **Preset Menu** (Figure 3-69) is displayed.

Figure 3-69: Preset Menu - Typical

```

--- Preset Menu ---
* #1:Preset 1
   Save Settings
   Recall Preset
  
```

- Press the Up or Down arrow keys, as required, to select the > **Recall Preset** option.
- Press the **SEL** key or Right arrow key and observe the > cursor changes to a ! cursor.
- Press the Up, Down, Right, or Left arrow keys, as required, to select the Preset programmed for the IF

IN MPEG or RF IN MPEG operation mode and press the **SEL** key.

11. Press the **ESC** key until the Main screen is displayed.
12. Press the Up arrow key, as required, to select the **COFDM Settings** option.

Notes In the following step, if the cursor adjacent to the **COFDM Settings** option is not a >> cursor, the wrong Preset has been selected for the IF IN MPEG or RF IN MPEG operation mode.

Repeat from [step 4](#) to select the correct Preset.

13. Verify the cursor adjacent to the **COFDM Settings** option is a >> cursor.
14. Press the **SEL** key or the Right arrow key and observe the **COFDM** menu ([Figure 3-70](#)) is displayed.

Figure 3-70: COFDM Menu - Typical

```

-----COFDM-----|
> Bandwidth (A): 6  |
  ModType: Unlk     |
  FEC: Unlk         |

```

15. Press the Up or Down arrow keys, as required, to select the >> **Metrics:** option.
16. Press the **SEL** or Right arrow key and observe the **COFDM Metrics** menu ([Figure 3-71](#)) is displayed.

Figure 3-71: COFDM Metrics Menu - Typical

```

--- COFDM Metrics ---|
* Lock: Unlocked     |
  SNR: 00.00         |
  Viterbi BER:       |

```

17. Press the Up or Down arrow keys, as required, to select the * **Lock:** option.
18. Observe **Lock:** indicates **Unlocked** or **Locked**.
19. Observe the Signal to Noise Ratio **SNR:** indication.
20. Press the Down arrow key to select the * **Post:** option as shown in [Figure 3-72](#).

Figure 3-72: COFDM Viterbi Bit Error Rates - Typical

```

-- COFDM Metrics --|
  Viterbi BER:      |
  Pre: 1.000e+00    |
* Post: 7.817e-03  |

```

21. Observe the Pre Viterbi (**Pre:**) and Post Viterbi (**Post**) Bit Error Rates (**BER**).
22. Press the **ESC** key until the Main screen is displayed.

3.8 Monitor/Change FMR Settings

If your MRX4000 PLUS configuration contains the FMR option, the procedures listed in [Table 3-5](#) are used to monitor or change internal FMR parameters or settings.

Table 3-5: Monitor/Change FMR Settings

Topic	Page
Monitor/Change Video Filter	3-39
Monitor/Change Video Deviation	3-40
Monitor/Change Channel 1, 2, 3, or 4 Sub-Carrier Frequencies	3-42
Monitor/Enable/Disable Channel 1, 2, 3, or 4	3-43
Monitor/Enable/Disable Channel 1, 2, 3, or 4 Filtering	3-45
Monitor/Enable/Disable Channel 1, 2, 3, or 4 De-Emphasis	3-46

See [Figure 3-73](#) on [page 3-38](#) for the FMR Settings Menu Map.

Figure 3-73: FMR Settings Menu Map

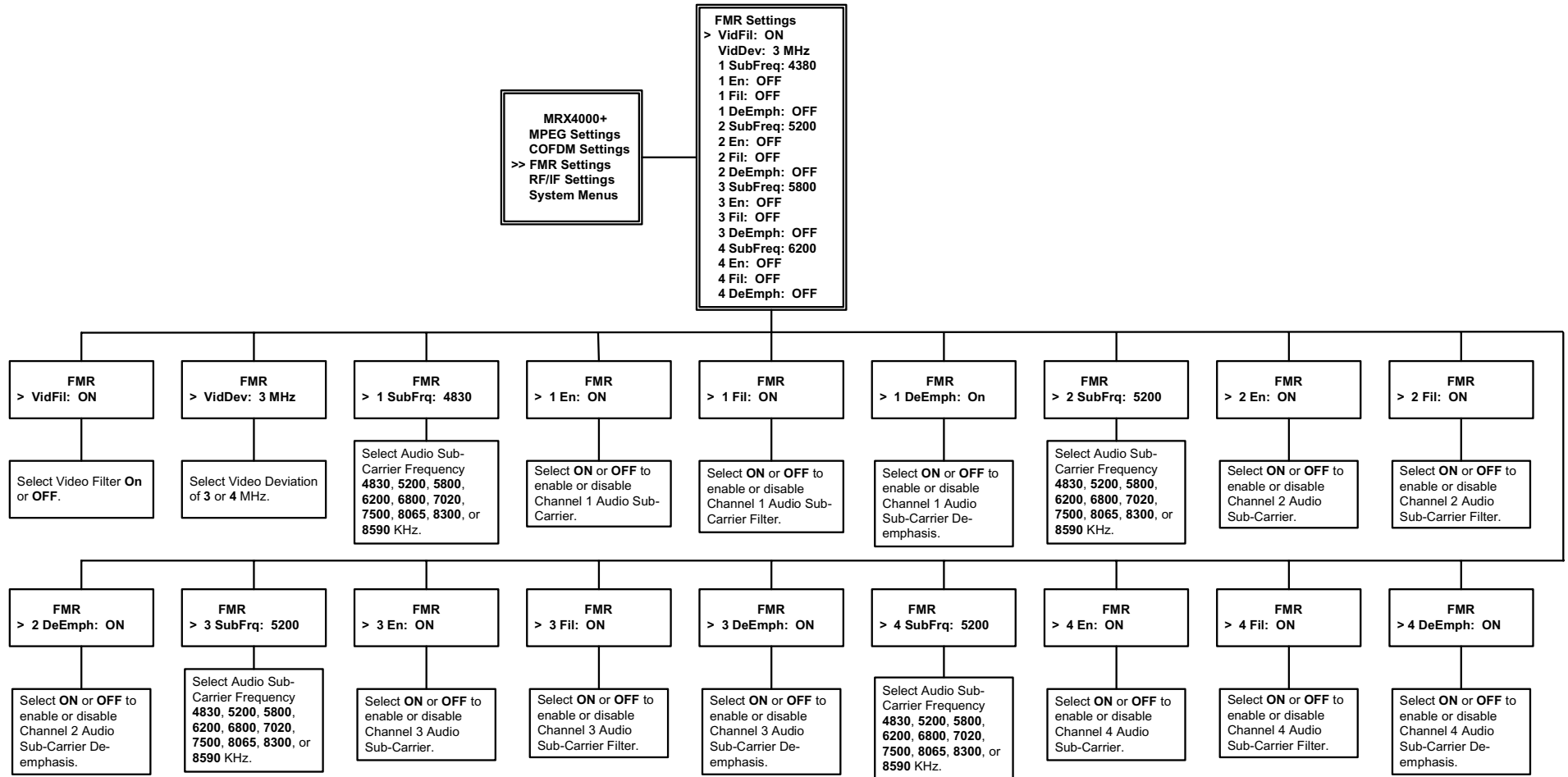

Notes Prior to monitoring or making any changes to the MRX4000 PLUS FMR Settings, you must determine which Preset or Presets have been set for the IF IN Analog or RF IN Analog operation mode using the Configurator software.

The Preset operation modes should have been recorded when the MRX4000 PLUS was programmed using the Configurator software.

3.8.1 Monitor/Change Video Filter

The procedure required to enable or disable FMR video filtering is contained in the following steps.

1. Verify the MRX4000 PLUS is powered up.
2. Verify the Main screen (Figure 3-74) is displayed. If the Main screen is not displayed, press the **ESC** key until the Main screen is displayed.

Figure 3-74: Main Screen Menu

```
----- MRX4000+ -----  
>> MPEG Settings  
    COFDM Settings  
    FMR Settings
```

3. Press the Up or Down arrow keys, as required, to move the cursor to the **FMR Settings** option.

Note If the cursor adjacent to the **FMR Settings** option is an asterisk (*), go to [step 4](#); if the cursor adjacent to the **FMR Settings** option is a >>, go to [step 13](#).

4. Press the Down arrow key to move the cursor to the Main screen **System Menu** option and press the **SEL** key.
5. Observe the **System Menu** (Figure 3-75) is displayed.

Figure 3-75: System Menu

```
--- System Menu ---  
>> Preset Menu  
    Active Errors  
    Error Log
```

6. Press the Up or Down arrow keys, as required, to select the >> **Preset Menu** option.
7. Observe the **Preset Menu** (Figure 3-76) is displayed.

Figure 3-76: Preset Menu - Typical

```
--- Preset Menu ---  
* #1:Preset 1  
    Save Settings  
    Recall Preset
```

8. Press the Up or Down arrow keys, as required, to select the > **Recall Preset** option.
9. Press the **SEL** key or Right arrow key and observe the > cursor changes to a ! cursor.
10. Press the Up, Down, Right, or Left arrow keys, as required, to select the Preset programmed for the IF

- IN Analog or RF IN Analog operation mode and press the **SEL** key.
11. Press the **ESC** key until the Main screen is displayed.
 12. Press the Up arrow key, as required, to select the **FMR Settings** option.

Notes In the following step, if the cursor adjacent to the **FMR Settings** option is not a >> cursor, the wrong Preset has been selected for the IF IN Analog or RF IN Analog operation mode.

Repeat from [step 4](#) to select the correct Preset.

-
13. Verify the cursor adjacent to the **FMR Settings** option is a >> cursor.
 14. Press the **SEL** key or the Right arrow key and observe the **FMR** menu ([Figure 3-77](#)) is displayed.

Figure 3-77: FMR Menu - Typical

```

----- FMR -----
> VidFil:  ON
  VidDev:  4 MHz
  1 SubFreq: 4830
  
```

15. Press the Up or Down arrow keys, as required, to select the > **VidFil:** option.
16. Press the Right arrow or **SEL** key and observe the > cursor adjacent to the **VidFil:** option changes to a ! cursor.
17. Press the Right, Left, Up, or Down arrow keys, as required, to select **ON** or **OFF**.

18. Press the **SEL** key and observe the ! cursor changes to a > cursor.
19. Press the **ESC** key until the Main screen is displayed.

3.8.2 Monitor/Change Video Deviation

The procedure required to change the FMR video deviation frequency is contained in the following steps.

1. Verify the MRX4000 PLUS is powered up.
2. Verify the Main screen ([Figure 3-78](#)) is displayed. If the Main screen is not displayed, press the **ESC** key until the Main screen is displayed.

Figure 3-78: Main Screen Menu

```

----- MRX4000+ -----
>> MPEG Settings
   COFDM Settings
   FMR Settings
  
```

3. Press the Up or Down arrow keys, as required, to move the cursor to the **FMR Settings** option.

Note If the cursor adjacent to the **FMR Settings** option is an asterisk (*), go to [step 4](#); if the cursor adjacent to the **FMR Settings** option is a >>, go to [step 13](#).

4. Press the Down arrow key to move the cursor to the Main screen **System Menus** option and press the **SEL** key.
5. Observe the **System Menu** ([Figure 3-79 on page 3-41](#)) is displayed.

Figure 3-79: System Menu

```
--- System Menu ---  
>> Preset Menu  
    Active Errors  
    Error Log
```

6. Press the Up or Down arrow keys, as required, to select the **>> Preset Menu** option.
7. Observe the **Preset Menu** (Figure 3-80) is displayed.

Figure 3-80: Preset Menu - Typical

```
--- Preset Menu ---  
* #1:Preset 1  
    Save Settings  
    Recall Preset
```

8. Press the Up or Down arrow keys, as required, to select the **> Recall Preset** option.
9. Press the **SEL** key or Right arrow key and observe the **>** cursor changes to a **!** cursor.
10. Press the Up, Down, Right, or Left arrow keys, as required, to select the Preset programmed for the IF IN Analog or RF IN Analog operation mode and press the **SEL** key.
11. Press the **ESC** key until the Main screen is displayed.
12. Press the Up arrow key, as required, to select the **FMR Settings** option.

Notes In the following step, if the cursor adjacent to the **FMR Settings** option is not a **>>** cursor, the wrong Preset has been selected for the IF IN Analog or RF IN Analog operation mode.

Repeat from [step 4](#) to select the correct Preset.

13. Verify the cursor adjacent to the **FMR Settings** option is a **>>** cursor.
14. Press the **SEL** key or the Right arrow key and observe the **FMR** menu (Figure 3-81) is displayed.

Figure 3-81: FMR Menu - Typical

```
----- FMR -----  
> VidFil: ON  
    VidDev: 4 MHz  
    1 SubFreq: 4830
```

15. Press the Up or Down arrow keys, as required, to select the **> VidDev:** option.
16. Press the Right arrow or **SEL** key and observe the **>** cursor adjacent to the **VidDev:** option changes to a **!** cursor.
17. Press the Right, Left, Up, or Down arrow keys, as required, to select **3** or **4**.
18. Press the **SEL** key and observe the **!** cursor changes to a **>** cursor.
19. Press the **ESC** key until the Main screen is displayed.

3.8.3 Monitor/Change Channel 1, 2, 3, or 4 Sub-Carrier Frequencies

The procedure required to change sub-carrier frequencies for Channels 1, 2, 3, or 4 is contained in the following steps.

1. Verify the MRX4000 PLUS is powered up.
2. Verify the Main screen (Figure 3-82) is displayed. If the Main screen is not displayed, press the **ESC** key until the Main screen is displayed.

Figure 3-82: Main Screen Menu

```
----- MRX4000+ -----  
>> MPEG Settings  
COFDM Settings  
FMR Settings
```

3. Press the Up or Down arrow keys, as required, to move the cursor to the **FMR Settings** option.

Note If the cursor adjacent to the **FMR Settings** option is an asterisk (*), go to [step 4](#); if the cursor adjacent to the **FMR Settings** option is a >>, go to [step 13](#).

4. Press the Down arrow key to move the cursor to the Main screen **System Menu** option and press the **SEL** key.
5. Observe the **System Menu** (Figure 3-83) is displayed.

Figure 3-83: System Menu

```
--- System Menu ---  
>> Preset Menu  
Active Errors  
Error Log
```

6. Press the Up or Down arrow keys, as required, to select the >> **Preset Menu** option.
7. Observe the **Preset Menu** (Figure 3-84) is displayed.

Figure 3-84: Preset Menu - Typical

```
--- Preset Menu ---  
* #1:Preset 1  
Save Settings  
Recall Preset
```

8. Press the Up or Down arrow keys, as required, to select the > **Recall Preset** option.
9. Press the **SEL** key or Right arrow key and observe the > cursor changes to a ! cursor.
10. Press the Up, Down, Right, or Left arrow keys, as required, to select the Preset programmed for the IF IN Analog or RF IN Analog operation mode and press the **SEL** key.
11. Press the **ESC** key until the Main screen is displayed.
12. Press the Up arrow key, as required, to select the **FMR Settings** option.

Notes In the following step, if the cursor adjacent to the **FMR Settings** option is not a >> cursor, the wrong Preset has been selected for the IF IN Analog or RF IN Analog operation mode.

Repeat from [step 4](#) to select the correct Preset.

13. Verify the cursor adjacent to the **FMR Settings** option is a >> cursor.
14. Press the **SEL** key or the Right arrow key and observe the **FMR** menu ([Figure 3-85](#)) is displayed.

Figure 3-85: FMR Menu - Typical

```
----- FMR -----  
> VidFil:  ON  
  VidDev:  4 MHz  
  1 SubFreq: 4830 |
```

Notes The steps required to change sub-carrier frequencies for Channels 1 thru 4 are identical.

In the following steps, “**X**” represents channel **1, 2, 3, or 4**. Select the Channel option contained in the **FMR** menu, as required, to monitor/change the sub-carrier frequency for that Channel.

15. Press the Up or Down arrow keys, as required, to select the > **X SubFrq**: option required.
16. Press the Right arrow or **SEL** key and observe the > cursor adjacent to the **X SubFrq**: option changes to a ! cursor.

17. Press the Right, Left, Up, or Down arrow keys, as required, to select one of the following sub-carrier frequencies:

4830, 5200, 5800, 6200, 6800, 7020, 7500, 8065, 8300, 8590

18. Press the **SEL** key and observe the ! cursor changes to a > cursor.
19. Repeat [step 15](#) thru [step 18](#) for each Channel sub-carrier to be monitored or changed.
20. Press the **ESC** key until the Main screen is displayed.

3.8.4 Monitor/Enable/Disable Channel 1, 2, 3, or 4

The procedure required to monitor, enable, or disable Channels 1, 2, 3, or 4 is contained in the following steps.

1. Verify the MRX4000 PLUS is powered up.
2. Verify the Main screen ([Figure 3-86](#)) is displayed. If the Main screen is not displayed, press the **ESC** key until the Main screen is displayed.

Figure 3-86: Main Screen Menu

```
----- MRX4000+ -----  
>> MPEG Settings  
    COFDM Settings  
    FMR Settings
```

3. Press the Up or Down arrow keys, as required, to move the cursor to the **FMR Settings** option.

Note If the cursor adjacent to the **FMR Settings** option is an asterisk (*), go to [step 4](#); if the cursor adjacent to the **FMR Settings** option is a >>, go to [step 13](#).

4. Press the Down arrow key to move the cursor to the Main screen **System Menu** option and press the **SEL** key.
5. Observe the **System Menu** ([Figure 3-87](#)) is displayed.

Figure 3-87: System Menu

```

--- System Menu ---
>> Preset Menu
    Active Errors
    Error Log
  
```

6. Press the Up or Down arrow keys, as required, to select the >> **Preset Menu** option.
7. Observe the **Preset Menu** ([Figure 3-88](#)) is displayed.

Figure 3-88: Preset Menu - Typical

```

--- Preset Menu ---
* #1:Preset 1
    Save Settings
    Recall Preset
  
```

8. Press the Up or Down arrow keys, as required, to select the > **Recall Preset** option.
9. Press the **SEL** key or Right arrow key and observe the > cursor changes to a ! cursor.
10. Press the Up, Down, Right, or Left arrow keys, as required, to select the Preset programmed for the IF

IN Analog or RF IN Analog operation mode and press the **SEL** key.

11. Press the **ESC** key until the Main screen is displayed.
12. Press the Up arrow key, as required, to select the **FMR Settings** option.

Notes In the following step, if the cursor adjacent to the **FMR Settings** option is not a >> cursor, the wrong Preset has been selected for the IF IN Analog or RF IN Analog operation mode.

Repeat from [step 4](#) to select the correct Preset.

13. Verify the cursor adjacent to the **FMR Settings** option is a >> cursor.
14. Press the **SEL** key or the Right arrow key and observe the **FMR** menu ([Figure 3-89](#)) is displayed.

Figure 3-89: FMR Menu - Typical

```

----- FMR -----
> VidFil: ON
  VidDev: 4 MHz
  1 SubFreq: 4830
  
```

Notes The steps required to change sub-carrier frequencies for Channels 1 thru 4 are identical.

In the following steps, “X” represents channel 1, 2, 3, or 4. Select the Channel option contained in the **FMR** menu, as required, to monitor, enable, or disable the Channel.

15. Press the Up or Down arrow keys, as required, to select the **> X En:** option required.
16. Press the Right arrow or **SEL** key and observe the **>** cursor adjacent to the **X En:** option changes to a **!** cursor.
17. Press the Right, Left, Up, or Down arrow keys, as required, to select **ON** or **OFF**.
18. Press the **SEL** key and observe the **!** cursor changes to a **>** cursor.
19. Repeat [step 15](#) thru [step 18](#) for each Channel to be monitored, enabled, or disabled.
20. Press the **ESC** key until the Main screen is displayed.

3.8.5 Monitor/Enable/Disable Channel 1, 2, 3, or 4 Filtering

The procedure required to monitor, enable, or disable Channels 1, 2, 3, or 4 filtering is contained in the following steps.

1. Verify the MRX4000 PLUS is powered up.
2. Verify the Main screen ([Figure 3-90](#)) is displayed. If the Main screen is not displayed, press the **ESC** key until the Main screen is displayed.

Figure 3-90: Main Screen Menu

```

----- MRX4000+ -----
>> MPEG Settings
    COFDM Settings
    FMR Settings
  
```

3. Press the Up or Down arrow keys, as required, to move the cursor to the **FMR Settings** option.

Note If the cursor adjacent to the **FMR Settings** option is an asterisk (*), go to [step 4](#); if the cursor adjacent to the **FMR Settings** option is a **>>**, go to [step 13](#).

4. Press the Down arrow key to move the cursor to the Main screen **System Menu** option and press the **SEL** key.
5. Observe the **System Menu** ([Figure 3-91](#)) is displayed.

Figure 3-91: System Menu

```

--- System Menu ---
>> Preset Menu
    Active Errors
    Error Log
  
```

6. Press the Up or Down arrow keys, as required, to select the **>> Preset Menu** option.
7. Observe the **Preset Menu** ([Figure 3-92](#)) is displayed.

Figure 3-92: Preset Menu - Typical

```

--- Preset Menu ---
* #1:Preset 1
    Save Settings
    Recall Preset
  
```

8. Press the Up or Down arrow keys, as required, to select the **> Recall Preset** option.
9. Press the **SEL** key or Right arrow key and observe the **>** cursor changes to a **!** cursor.
10. Press the Up, Down, Right, or Left arrow keys, as required, to select the Preset programmed for the IF

- IN Analog or RF IN Analog operation mode and press the **SEL** key.
11. Press the **ESC** key until the Main screen is displayed.
 12. Press the Up arrow key, as required, to select the **FMR Settings** option.

Notes In the following step, if the cursor adjacent to the **FMR Settings** option is not a >> cursor, the wrong Preset has been selected for the IF IN Analog or RF IN Analog operation mode.

Repeat from [step 4](#) to select the correct Preset.

13. Verify the cursor adjacent to the **FMR Settings** option is a >> cursor.
14. Press the **SEL** key or the Right arrow key and observe the **FMR** menu ([Figure 3-93](#)) is displayed.

Figure 3-93: FMR Menu - Typical

```

----- FMR -----
> VidFil:  ON
  VidDev:  4 MHz
  1 SubFreq: 4830
  
```

Notes The steps required to change filtering for Channels 1 thru 4 are identical.

In the following steps, “**X**” represents channel **1**, **2**, **3**, or **4**. Select the Channel option contained in the **FMR** menu, as required, to monitor, enable, or disable filtering for that Channel.

15. Press the Up or Down arrow keys, as required, to select the **> X Fil:** option required.
16. Press the Right arrow or **SEL** key and observe the > cursor adjacent to the **X Fil:** option changes to a ! cursor.
17. Press the Right, Left, Up, or Down arrow keys, as required, to select **ON** or **OFF**.
18. Press the **SEL** key and observe the ! cursor changes to a > cursor.
19. Repeat [step 15](#) thru [step 18](#) for each Channel filter to be monitored, enabled, or disabled.
20. Press the **ESC** key until the Main screen is displayed.

3.8.6 Monitor/Enable/Disable Channel 1, 2, 3, or 4 De-Emphasis

The procedure required to monitor, enable, or disable Channels 1, 2, 3, or 4 De-Emphasis is contained in the following steps.

1. Verify the MRX4000 PLUS is powered up.
2. Verify the Main screen ([Figure 3-94](#)) is displayed. If the Main screen is not displayed, press the **ESC** key until the Main screen is displayed.

Figure 3-94: Main Screen Menu

```

----- MRX4000+ -----
>> MPEG Settings
   COFDM Settings
   FMR Settings
  
```

3. Press the Up or Down arrow keys, as required, to move the cursor to the **FMR Settings** option.

Note If the cursor adjacent to the **FMR Settings** option is an asterisk (*), go to [step 4](#); if the cursor adjacent to the **FMR Settings** option is a >>, go to [step 13](#).

4. Press the Down arrow key to move the cursor to the Main screen **System Menu** option and press the **SEL** key.
5. Observe the **System Menu** ([Figure 3-95](#)) is displayed.

Figure 3-95: System Menu

```

--- System Menu ---
>> Preset Menu
    Active Errors
    Error Log
  
```

6. Press the Up or Down arrow keys, as required, to select the >> **Preset Menu** option.
7. Observe the **Preset Menu** ([Figure 3-96](#)) is displayed.

Figure 3-96: Preset Menu - Typical

```

--- Preset Menu ---
* #1: Preset 1
    Save Settings
    Recall Preset
  
```

8. Press the Up or Down arrow keys, as required, to select the > **Recall Preset** option.
9. Press the **SEL** key or Right arrow key and observe the > cursor changes to a ! cursor.
10. Press the Up, Down, Right, or Left arrow keys, as required, to select the Preset programmed for the IF

IN Analog or RF IN Analog operation mode and press the **SEL** key.

11. Press the **ESC** key until the Main screen is displayed.
12. Press the Up arrow key, as required, to select the **FMR Settings** option.

Notes In the following step, if the cursor adjacent to the **FMR Settings** option is not a >> cursor, the wrong Preset has been selected for the IF IN Analog or RF IN Analog operation mode.

Repeat from [step 4](#) to select the correct Preset.

13. Verify the cursor adjacent to the **FMR Settings** option is a >> cursor.
14. Press the **SEL** key or the Right arrow key and observe the **FMR** menu ([Figure 3-97](#)) is displayed.

Figure 3-97: FMR Menu - Typical

```

----- FMR -----
> VidFil: ON
   VidDev: 4 MHz
   1 SubFreq: 4830
  
```

Notes The steps required to change sub-carrier frequencies for Channels 1 thru 4 are identical.

In the following steps, “**X**” represents channel **1, 2, 3, or 4**. Select the Channel option contained in the **FMR** menu, as required, to monitor, enable, or disable De-Emphasis for that Channel.

15. Press the Up or Down arrow keys, as required, to select the **> X DeEmph:** option required.
16. Press the Right arrow or **SEL** key and observe the **>** cursor adjacent to the **X DeEmph:** option changes to a **!** cursor.
17. Press the Right, Left, Up, or Down arrow keys, as required, to select **ON** or **OFF**.
18. Press the **SEL** key and observe the **!** cursor changes to a **>** cursor.
19. Repeat [step 15](#) thru [step 18](#) for each Channel de-emphasis to be monitored, enabled, or disabled.
20. Press the **ESC** key until the Main screen is displayed.

3.9 Monitor/Change MRX4000 PLUS RF/IF Section Settings

The procedures listed in [Table 3-6](#) are used to monitor or change internal RF/IF section parameters or settings.

Table 3-6: Monitor/Change RF/IF Section Settings

Topic	Page	Monitor Only	Change
Monitor Channel Frequency	3-50	✓	
Monitor Received Carrier Level	3-51	✓	
Monitor Link Quality	3-52	✓	
Select Frequency Band	3-53		✓
Monitor Channel Bandwidth	3-55	✓	
Select Channel and Offset	3-56		✓
Change Filter Setting	3-58		✓
Change Squelch Level	3-59		✓
Change Analog/Digital Operation Mode	3-61		✓
Change IF/RF Operation Mode	3-63		✓

See [Figure 3-98](#) on [page 3-49](#) for the MRX4000 PLUS RF/IF Settings Menu Map.

Figure 3-98: MRX4000 PLUS RF/IF Settings Menu Map

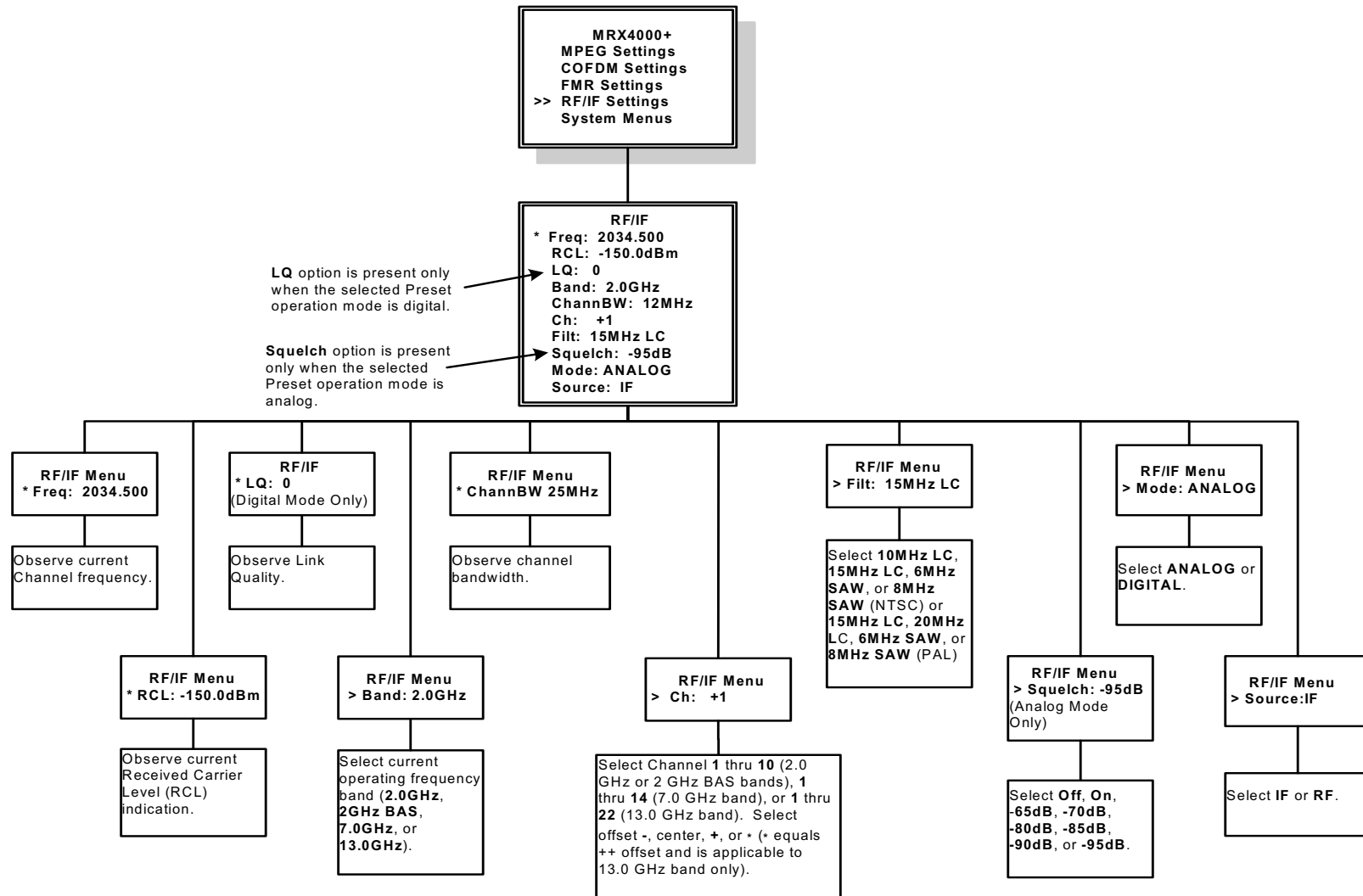

3.9.1 Monitor Channel Frequency

The procedure required to monitor the current Preset RF/IF channel frequency is contained in the following steps.

1. Verify the MRX4000 PLUS is powered up.
2. Verify the Main screen (Figure 3-99) is displayed. If the Main screen is not displayed, press the **ESC** key until the Main screen is displayed.

Figure 3-99: Main Screen Menu

```
----- MRX4000+ -----
>> MPEG Settings
    COFDM Settings
    FMR Settings
```

3. Press the Up or Down arrow keys, as required, to move the cursor to the **RF/IF Settings** option. See Figure 3-100.

Figure 3-100: Main Menu - RF/IF Settings Option

```
----- MRX4000+ -----
    FMR Settings
>> RF/IF Settings
    System Menus
```

4. Press the Down arrow key to move the cursor to the Main screen **System Menus** option and press the **SEL** key.
5. Observe the **System Menu** (Figure 3-101) is displayed.

Figure 3-101: System Menu

```
--- System Menu ---
>> Preset Menu
    Active Errors
    Error Log
```

6. Press the Up or Down arrow keys, as required, to select the **>> Preset Menu** option.
7. Observe the **Preset Menu** (Figure 3-102) is displayed.

Figure 3-102: Preset Menu - Typical

```
--- Preset Menu ---
* #1:Preset 1
    Save Settings
    Recall Preset
```

8. Press the Up or Down arrow keys, as required, to select the **> Recall Preset** option.
9. Press the **SEL** key or Right arrow key and observe the **>** cursor changes to a **!** cursor.
10. Press the Up, Down, Right, or Left arrow keys, as required, to select the Preset required and press the **SEL** key.
11. Press the **ESC** key until the Main screen is displayed.
12. Press the Up arrow key, as required, to select the **RF/IF Settings** option. See Figure 3-103.

Figure 3-103: Main Screen Menu - RF/IF Option

```
----- MRX4000+ -----
    FMR Settings
>> RF/IF Settings
    System Menus
```

13. Verify the cursor adjacent to the **RF/IF Settings** option is a >> cursor.
14. Press the **SEL** key or the Right arrow key and observe the **RF/IF** menu ([Figure 3-104](#)) is displayed.

Figure 3-104: RF/IF Menu - Typical

```

----- RF/IF -----
* Freq: 2031.500
  RCL: -150.0dBm
  LQ: 0

```

15. Press the Up or Down arrow keys, as required, to select the * **Freq:** option.
16. Observe the **Freq:** indication.
17. Press the **ESC** key until the Main screen is displayed.

3.9.2 Monitor Received Carrier Level

The procedure required to monitor Received Carrier Level (RCL) is contained in the following steps.

1. Verify the MRX4000 PLUS is powered up.
2. Verify the Main screen ([Figure 3-105](#)) is displayed. If the Main screen is not displayed, press the **ESC** key until the Main screen is displayed.

Figure 3-105: Main Screen Menu

```

----- MRX4000+ -----
>> MPEG Settings
    COFDM Settings
    FMR Settings

```

3. Press the Up or Down arrow keys, as required, to move the cursor to the **RF/IF Settings** option. [See Figure 3-106](#).

Figure 3-106: Main Menu - RF/IF Settings Option

```

----- MRX4000+ -----
    FMR Settings
  >> RF/IF Settings
    System Menu

```

4. Press the Down arrow key to move the cursor to the Main screen **System Menus** option and press the **SEL** key.
5. Observe the **System Menu** ([Figure 3-107](#)) is displayed.

Figure 3-107: System Menu

```

--- System Menu ---
  >> Preset Menu
    Active Errors
    Error Log

```

6. Press the Up or Down arrow keys, as required, to select the >> **Preset Menu** option.
7. Observe the **Preset Menu** ([Figure 3-108](#)) is displayed.

Figure 3-108: Preset Menu - Typical

```

--- Preset Menu ---
* #1:Preset 1
  Save Settings
  Recall Preset

```

8. Press the Up or Down arrow keys, as required, to select the **> Recall Preset** option.
9. Press the **SEL** key or Right arrow key and observe the **>** cursor changes to a **!** cursor.
10. Press the Up, Down, Right, or Left arrow keys, as required, to select the Preset required and press the **SEL** key.
11. Press the **ESC** key until the Main screen is displayed.
12. Press the Up arrow key, as required, to select the **RF/IF Settings** option. See Figure 3-109.

Figure 3-109: Main Screen Menu - RF/IF Option

```

----- MRX4000+ -----
      FMR Settings
    >> RF/IF Settings
      System Menu
  
```

13. Verify the cursor adjacent to the **RF/IF Settings** option is a **>>** cursor.
14. Press the **SEL** key or the Right arrow key and observe the **RF/IF** menu (Figure 3-110) is displayed.

Figure 3-110: RF/IF Menu - Typical

```

----- RF/IF -----
* Freq: 2031.500
  RCL: -150.0dBm
  LQ: 0
  
```

15. Press the Up or Down arrow keys, as required, to select the *** RCL:** option.
16. Observe the **RCL:** indication.

17. Press the **ESC** key until the Main screen is displayed.

3.9.3 Monitor Link Quality

The procedure required to monitor Link Quality (LQ) is contained in the following steps.

Note	Link Quality (LQ) may be monitored only if the selected Preset operation mode is set to RF IN MPEG or IF IN MPEG.
-------------	--

1. Verify the MRX4000 PLUS is powered up.
2. Verify the Main screen (Figure 3-111) is displayed. If the Main screen is not displayed, press the **ESC** key until the Main screen is displayed.

Figure 3-111: Main Screen Menu

```

----- MRX4000+ -----
    >> MPEG Settings
      COFDM Settings
      FMR Settings
  
```

3. Press the Up or Down arrow keys, as required, to move the cursor to the **RF/IF Settings** option. See Figure 3-112.

Figure 3-112: Main Menu - RF/IF Settings Option

```

----- MRX4000+ -----
      FMR Settings
    >> RF/IF Settings
      System Menu
  
```

- Press the Down arrow key to move the cursor to the Main screen **System Menu** option and press the **SEL** key.
- Observe the **System Menu** (Figure 3-113) is displayed.

Figure 3-113: System Menu

```

--- System Menu ---
>> Preset Menu
    Active Errors
    Error Log
  
```

- Press the Up or Down arrow keys, as required, to select the **>> Preset Menu** option.
- Observe the **Preset Menu** (Figure 3-114) is displayed.

Figure 3-114: Preset Menu - Typical

```

--- Preset Menu ---
* #1:Preset 1
  Save Settings
  Recall Preset
  
```

- Press the Up or Down arrow keys, as required, to select the **> Recall Preset** option.
- Press the **SEL** key or Right arrow key and observe the **>** cursor changes to a **!** cursor.
- Press the Up, Down, Right, or Left arrow keys, as required, to select the digital Preset required and press the **SEL** key.
- Press the **ESC** key until the Main screen is displayed.
- Press the Up arrow key, as required, to select the **RF/IF Settings** option. See Figure 3-115.

Figure 3-115: Main Screen Menu - RF/IF Option

```

----- MRX4000+ -----
      FMR Settings
      >> RF/IF Settings
      System Menu
  
```

- Verify the cursor adjacent to the **RF/IF Settings** option is a **>>** cursor.
- Press the **SEL** key or the Right arrow key and observe the **RF/IF** menu (Figure 3-116) is displayed.

Figure 3-116: RF/IF Menu - Typical

```

----- RF/IF -----
* Freq: 2031.500
  RCL: -150.0dBm
  LQ: 0
  
```

- Press the Up or Down arrow keys, as required, to select the *** LQ:** option.
- Observe the **LQ:** indication.
- Press the **ESC** key until the Main screen is displayed.

3.9.4 Select Frequency Band

The procedure required to select the MRX4000 PLUS frequency band is contained in the following steps.

- Verify the MRX4000 PLUS is powered up.
- Verify the Main screen (Figure 3-117 on page 3-54) is displayed. If the Main screen is not displayed, press the **ESC** key until the Main screen is displayed.

Figure 3-117: Main Screen Menu

```
----- MRX4000+ -----  
>> MPEG Settings  
    COFDM Settings  
    FMR Settings
```

3. Press the Up or Down arrow keys, as required, to move the cursor to the **RF/IF Settings** option. See [Figure 3-118](#).

Figure 3-118: Main Menu - RF/IF Settings Option

```
----- MRX4000+ -----  
    FMR Settings  
>> RF/IF Settings  
    System Menu
```

4. Press the Down arrow key to move the cursor to the Main screen **System Menu** option and press the **SEL** key.
5. Observe the **System Menu** ([Figure 3-119](#)) is displayed.

Figure 3-119: System Menu

```
--- System Menu ---  
>> Preset Menu  
    Active Errors  
    Error Log
```

6. Press the Up or Down arrow keys, as required, to select the **>> Preset Menu** option.

7. Observe the **Preset Menu** ([Figure 3-120](#)) is displayed.

Figure 3-120: Preset Menu - Typical

```
--- Preset Menu ---  
* #1:Preset 1  
    Save Settings  
    Recall Preset
```

8. Press the Up or Down arrow keys, as required, to select the **> Recall Preset** option.
9. Press the **SEL** key or Right arrow key and observe the **>** cursor changes to a **!** cursor.
10. Press the Up, Down, Right, or Left arrow keys, as required, to select the Preset required and press the **SEL** key.
11. Press the **ESC** key until the Main screen is displayed.
12. Press the Up arrow key, as required, to select the **RF/IF Settings** option. See [Figure 3-121](#).

Figure 3-121: Main Screen Menu - RF/IF Option

```
----- MRX4000+ -----  
    FMR Settings  
>> RF/IF Settings  
    System Menu
```

13. Verify the cursor adjacent to the **RF/IF Settings** option is a **>>** cursor.
14. Press the **SEL** key or the Right arrow key and observe the **RF/IF** menu ([Figure 3-122 on page 3-55](#)) is displayed.

Figure 3-122: RF/IF Menu - Typical

```
----- RF/IF -----  
RCL: -150.0dBm  
LQ: 0  
> Band: 2.0GHz
```

15. Press the Up or Down arrow keys, as required, to select the **> Band:** option.
16. Press the **SEL** key or Right arrow key and observe the **>** cursor changes to a **!** cursor.
17. Press the Up, Down, Right, or Left arrow keys, as required, to select **2.0GHz**, **2GHz BAS**, **7.0GHz**, or **13.0GHz**, as required and press the **SEL** key.
18. Observe the selected **Band:** indication.
19. Press the **ESC** key until the Main screen is displayed.

3.9.5 Monitor Channel Bandwidth

The procedure required to monitor the MRX4000 PLUS channel bandwidth is contained in the following steps.

1. Verify the MRX4000 PLUS is powered up.
2. Verify the Main screen (Figure 3-123) is displayed. If the Main screen is not displayed, press the **ESC** key until the Main screen is displayed.

Figure 3-123: Main Screen Menu

```
----- MRX4000+ -----  
>> MPEG Settings  
COFDM Settings  
FMR Settings
```

3. Press the Up or Down arrow keys, as required, to move the cursor to the **RF/IF Settings** option. See Figure 3-124.

Figure 3-124: Main Menu - RF/IF Settings Option

```
----- MRX4000+ -----  
FMR Settings  
>> RF/IF Settings  
System Menus
```

4. Press the Down arrow key to move the cursor to the Main screen **System Menus** option and press the **SEL** key.
5. Observe the **System Menu** (Figure 3-125) is displayed.

Figure 3-125: System Menu

```
--- System Menu ---  
>> Preset Menu  
Active Errors  
Error Log
```

6. Press the Up or Down arrow keys, as required, to select the **>> Preset Menu** option.
7. Observe the **Preset Menu** (Figure 3-126) is displayed.

Figure 3-126: Preset Menu - Typical

```
--- Preset Menu ---  
* #1:Preset 1  
Save Settings  
Recall Preset
```

8. Press the Up or Down arrow keys, as required, to select the **> Recall Preset** option.
9. Press the **SEL** key or Right arrow key and observe the **>** cursor changes to a **!** cursor.
10. Press the Up, Down, Right, or Left arrow keys, as required, to select the Preset required and press the **SEL** key.
11. Press the **ESC** key until the Main screen is displayed.
12. Press the Up arrow key, as required, to select the **RF/IF Settings** option. See [Figure 3-127](#).

Figure 3-127: Main Screen Menu - RF/IF Option

```

----- MRX4000+ -----
      FMR Settings
  >> RF/IF Settings
      System Menu
  
```

13. Verify the cursor adjacent to the **RF/IF Settings** option is a **>>** cursor.
14. Press the **SEL** key or the Right arrow key and observe the **RF/IF** menu ([Figure 3-128](#)) is displayed.

Figure 3-128: RF/IF Menu - Typical

```

----- RF/IF -----
  * ChannBW: 25MHz
    Ch:      1
    Filt: 15MHz LC
  
```

15. Press the Up or Down arrow keys, as required, to select the *** ChannBW:** option.
16. Observe the **ChannBW:** indication.

17. Press the **ESC** key until the Main screen is displayed.

3.9.6 Select Channel and Offset

The procedure required to change the MRX4000 PLUS channel and channel offset is contained in the following steps.

1. Verify the MRX4000 PLUS is powered up.
2. Verify the Main screen ([Figure 3-129](#)) is displayed. If the Main screen is not displayed, press the **ESC** key until the Main screen is displayed.

Figure 3-129: Main Screen Menu

```

----- MRX4000+ -----
  >> MPEG Settings
      COFDM Settings
      FMR Settings
  
```

3. Press the Up or Down arrow keys, as required, to move the cursor to the **RF/IF Settings** option. See [Figure 3-130](#).

Figure 3-130: Main Menu - RF/IF Settings Option

```

----- MRX4000+ -----
      FMR Settings
  >> RF/IF Settings
      System Menu
  
```

4. Press the Down arrow key to move the cursor to the Main screen **System Menu** option and press the **SEL** key.
5. Observe the **System Menu** ([Figure 3-131 on page 3-57](#)) is displayed.

Figure 3-131: System Menu

```
--- System Menu ---  
>> Preset Menu  
    Active Errors  
    Error Log
```

6. Press the Up or Down arrow keys, as required, to select the **>> Preset Menu** option.
7. Observe the **Preset Menu** (Figure 3-132) is displayed.

Figure 3-132: Preset Menu - Typical

```
--- Preset Menu ---  
* #1:Preset 1  
    Save Settings  
    Recall Preset
```

8. Press the Up or Down arrow keys, as required, to select the **> Recall Preset** option.
9. Press the **SEL** key or Right arrow key and observe the **>** cursor changes to a **!** cursor.
10. Press the Up, Down, Right, or Left arrow keys, as required, to select the Preset required and press the **SEL** key.
11. Press the **ESC** key until the Main screen is displayed.
12. Press the Up arrow key, as required, to select the **RF/IF Settings** option. See Figure 3-133.

Figure 3-133: Main Screen Menu - RF/IF Option

```
---- MRX4000+ ----  
    FMR Settings  
>> RF/IF Settings  
    System Menus
```

13. Verify the cursor adjacent to the **RF/IF Settings** option is a **>>** cursor.
14. Press the **SEL** key or the Right arrow key and observe the **RF/IF** menu (Figure 3-134) is displayed.

Figure 3-134: RF/IF Menu - Typical

```
----- RF/IF -----  
* ChannBW: 25MHz  
    Ch: 1  
    Filt: 15MHz LC
```

15. Press the Up or Down arrow keys, as required, to select the **> Ch:** option.
16. Press the **SEL** key and observe the **>** cursor changes to a **!** cursor.

Notes In the following steps, press the Up or Down arrow keys to select channel **1** thru **10** (2 GHz and 2 GHz BAS bands), channel **1** thru **14** (7 GHz Band), or **1** thru **22** (13 GHz band).

Press the Left or Right arrow keys to select the channel offset (**-**, center, **+**, or *****). The ***** symbol represents the **++** offset and is applicable to the 13 GHz band only.

When the center offset is selected, no character will be displayed adjacent to the channel number.

-
17. Press the Up or Down arrow keys to select the channel required.

18. Press the Left or Right arrow keys to select the -, center, +, or * (++) channel offset, as required, and press the **SEL** key.
19. Press the **ESC** key until the Main screen is displayed.

3.9.7 Change Filter Setting

The procedure required to change the MRX4000 PLUS filter setting is contained in the following steps.

1. Verify the MRX4000 PLUS is powered up.
2. Verify the Main screen (Figure 3-135) is displayed. If the Main screen is not displayed, press the **ESC** key until the Main screen is displayed.

Figure 3-135: Main Screen Menu

```

----- MRX4000+ -----
>> MPEG Settings
    COFDM Settings
    FMR Settings
  
```

3. Press the Up or Down arrow keys, as required, to move the cursor to the **RF/IF Settings** option. See Figure 3-136.

Figure 3-136: Main Menu - RF/IF Settings Option

```

----- MRX4000+ -----
    FMR Settings
  >> RF/IF Settings
    System Menu
  
```

4. Press the Down arrow key to move the cursor to the Main screen **System Menu** option and press the **SEL** key.

5. Observe the **System Menu** (Figure 3-137) is displayed.

Figure 3-137: System Menu

```

--- System Menu ---
>> Preset Menu
    Active Errors
    Error Log
  
```

6. Press the Up or Down arrow keys, as required, to select the **>> Preset Menu** option.
7. Observe the **Preset Menu** (Figure 3-138) is displayed.

Figure 3-138: Preset Menu - Typical

```

--- Preset Menu ---
* #1:Preset 1
    Save Settings
    Recall Preset
  
```

8. Press the Up or Down arrow keys, as required, to select the **> Recall Preset** option.
9. Press the **SEL** key or Right arrow key and observe the **>** cursor changes to a **!** cursor.
10. Press the Up, Down, Right, or Left arrow keys, as required, to select the Preset required and press the **SEL** key.
11. Press the **ESC** key until the Main screen is displayed.
12. Press the Up arrow key, as required, to select the **RF/IF Settings** option. See Figure 3-139 on page 3-59.

Figure 3-139: Main Screen Menu - RF/IF Option

```

----- MRX4000+ -----
      FMR Settings
  >> RF/IF Settings
      System Menu
  
```

13. Verify the cursor adjacent to the **RF/IF Settings** option is a >> cursor.
14. Press the **SEL** key or the Right arrow key and observe the **RF/IF** menu ([Figure 3-140](#)) is displayed.

Figure 3-140: RF/IF Menu - Typical

```

----- RF/IF -----
* ChannBW: 25MHz
  Ch: 1
  Filt: 15MHz LC
  
```

15. Press the Up or Down arrow keys, as required, to select the > **Filt:** option.
16. Press the **SEL** key and observe the > cursor changes to a ! cursor.

Notes In the following step, **10MHz LC** and **15MHz LC** (NTSC) or **15MHz LC** and **20MHz LC** (PAL) options are available for Presets with analog operation modes.

10MHz LC, 15MHz LC, 6MHz SAW, or 8MHz SAW (NTSC) or **15MHz LC, 20MHz LC, 6MHz SAW, or 8MHz SAW** (PAL) options are available for Presets with digital operation modes.

17. Press the Up, Down, Left, or Right arrow keys to select **10MHz LC, 15MHz LC, 6MHz SAW, or 8MHz SAW** (NTSC options) or **15MHz LC, 20MHz LC, 6MHz SAW, or 8MHz SAW** (PAL options), as required, and press the **SEL** key.
18. Press the **ESC** key until the Main screen is displayed.

3.9.8 Change Squelch Level

The procedure required to change the RF/IF section squelch level is contained in the following steps.

Note	Squelch settings may be changed only if the selected Preset operation mode is set to RF IN Analog or IF IN Analog.
-------------	--

1. Verify the MRX4000 PLUS is powered up.
2. Verify the Main screen ([Figure 3-141](#)) is displayed. If the Main screen is not displayed, press the **ESC** key until the Main screen is displayed.

Figure 3-141: Main Screen Menu

```

----- MRX4000+ -----
  >> MPEG Settings
      COFDM Settings
      FMR Settings
  
```

3. Press the Up or Down arrow keys, as required, to move the cursor to the **RF/IF Settings** option. See [Figure 3-142 on page 3-60](#).

Figure 3-142: Main Menu - RF/IF Settings Option

```
----- MRX4000+ -----  
      FMR Settings  
>> RF/IF Settings  
      System Menu
```

4. Press the Down arrow key to move the cursor to the Main screen **System Menu** option and press the **SEL** key.
5. Observe the **System Menu** (Figure 3-143) is displayed.

Figure 3-143: System Menu

```
---- System Menu ----  
>> Preset Menu  
      Active Errors  
      Error Log
```

6. Press the Up or Down arrow keys, as required, to select the **>> Preset Menu** option.
7. Observe the **Preset Menu** (Figure 3-144) is displayed.

Figure 3-144: Preset Menu - Typical

```
---- Preset Menu ----  
* #1:Preset 1  
      Save Settings  
      Recall Preset
```

8. Press the Up or Down arrow keys, as required, to select the **> Recall Preset** option.
9. Press the **SEL** key or Right arrow key and observe the **>** cursor changes to a **!** cursor.

10. Press the Up, Down, Right, or Left arrow keys, as required, to select the Preset required and press the **SEL** key.
11. Press the **ESC** key until the Main screen is displayed.
12. Press the Up arrow key, as required, to select the **RF/IF Settings** option. See Figure 3-145.

Figure 3-145: Main Screen Menu - RF/IF Option

```
----- MRX4000+ -----  
      FMR Settings  
>> RF/IF Settings  
      System Menu
```

13. Verify the cursor adjacent to the **RF/IF Settings** option is a **>>** cursor.
14. Press the **SEL** key or the Right arrow key and observe the **RF/IF** menu (Figure 3-146) is displayed.

Figure 3-146: RF/IF Menu - Typical

```
┌----- RF/IF -----┐  
Ch: 1  
> Filt: 15MHz LC  
Squelch: Off
```

Notes The **Squelch:** option will be displayed on the **RF/IF** menu only for Presets with an operation mode of RF IN Analog.

If the **Squelch:** option is not displayed on the **RF/IF** menu, repeat from [step 2](#) and select a Preset with an operation mode of RF IN Analog.

15. Press the Up or Down arrow keys, as required, to select the **> Squelch:** option.
16. Press the **SEL** key and observe the **>** cursor changes to a **!** cursor.
17. Press the Up, Down, Left, or Right arrow keys to select **Off, On, -65dB, -70dB, -75dB, -80dB, -85dB, -90dB,** or **-95dB**, as required, and press the **SEL** key.
18. Press the **ESC** key until the Main screen is displayed.

3.9.9 Change Analog/Digital Operation Mode

The procedure required to change the operation mode from analog to digital or from digital to analog is contained in the following steps.

This procedure allows you to change the operation mode from the MRX4000 PLUS front panel without using the Configurator software. The operation mode may be changed from analog to digital or from digital to analog while retaining the current Preset settings. The changes may be saved as a specific Preset, as required.

Changing the operation mode from analog to digital or from digital to analog requires additional changes to RF/IF, COFDM, MPEG, and/or FMR settings in the radio. Steps are provided to ensure the proper settings required for analog/digital operations are properly set for the applicable operation mode.

If the changes are not saved as a Preset, the new settings will be retained until a Preset is selected. If the MRX4000 PLUS is powered down, the MRX4000 PLUS will retain the new settings, even if the settings were not saved as a Preset. Settings will be retained upon power up. When a new Preset is selected, the settings will be lost. The steps required to save the new operation mode settings as a Preset are provided in this procedure.

1. Verify the MRX4000 PLUS is powered up.
2. Verify the Main screen ([Figure 3-147](#)) is displayed. If the Main screen is not displayed, press the **ESC** key until the Main screen is displayed.

Figure 3-147: Main Screen Menu

```

----- MRX4000+ -----
>> MPEG Settings
      COFDM Settings
      FMR Settings
  
```

3. Press the Up or Down arrow keys, as required, to move the cursor to the **RF/IF Settings** option. See [Figure 3-148](#).

Figure 3-148: Main Menu - RF/IF Settings Option

```

----- MRX4000+ -----
      FMR Settings
>> RF/IF Settings
      System Menu
  
```

4. Verify the cursor adjacent to the **RF/IF Settings** option is a **>>** cursor.
5. Press the **SEL** key or the Right arrow key and observe the **RF/IF** menu ([Figure 3-149](#)) is displayed.

Figure 3-149: RF/IF Menu - Typical

```

----- RF/IF -----
Ch: 1
> Filt: 15MHz LC
      Squelch: Off
  
```

6. Press the Up or Down arrow keys, as required, to select the **> Mode:** option.
7. Press the **SEL** key and observe the **>** cursor changes to a **!** cursor.
8. Press the Up, Down, Left, or Right arrow keys to select **ANALOG** or **DIGITAL**, as required, and press the **SEL** key.
9. Perform “Change Filter Setting” on page 3-58, as required, to select the filter setting required.

Note If the **Mode:** option selected in step 8 was **ANALOG**, perform step 10 and go to step 16.

If the **Mode:** option selected in step 8 was **DIGITAL**, go to step 11.

10. Perform “Change Squelch Level” on page 3-59, as required.
11. Perform “Monitor/Change Bandwidth” on page 3-30, as required.
12. Perform “Monitor/Change Color Bars” on page 3-16, as required.
13. Perform “Monitor/Change Audio Output Mode Setting” on page 3-17, as required.
14. Perform “Monitor/Change NTSC Pedestal” on page 3-18, as required.
15. Perform “Monitor/Change BISS Settings” on page 3-20, as required, and go to step 22.
16. Perform “Monitor/Change Video Filter” on page 3-39, as required.

17. Perform “Monitor/Change Video Deviation” on page 3-40, as required.
18. Perform “Monitor/Change Channel 1, 2, 3, or 4 Sub-Carrier Frequencies” on page 3-42, as required.
19. Perform “Monitor/Enable/Disable Channel 1, 2, 3, or 4” on page 3-43, as required.
20. Perform “Monitor/Enable/Disable Channel 1, 2, 3, or 4 Filtering” on page 3-45, as required.
21. Perform “Monitor/Enable/Disable Channel 1, 2, 3, or 4 De-Emphasis” on page 3-46, as required.

Notes If the new settings are to be saved as a Preset, go to step 22.

If the settings are not to be saved as a Preset, this procedure is complete.

22. Verify the Main screen (Figure 3-150) is displayed. If the Main screen is not displayed, press the **ESC** key until the Main screen is displayed.

Figure 3-150: Main Screen Menu

```

  [----- MRX4000+ -----]
  | >> MPEG Settings          |
  |       COFDM Settings     |
  |       FMR Settings       |
  |-----|

```

23. Press the Down arrow key to move the cursor to the Main screen **System Menus** option and press the **SEL** key.
24. Observe the **System Menu** (Figure 3-151 on page 3-63) is displayed.

Figure 3-151: System Menu

```
--- System Menu ---
>> Preset Menu
    Active Errors
    Error Log
```

25. Press the Up or Down arrow keys, as required, to select the **>> Preset Menu** option.
26. Press the **SEL** key and observe the **Preset Menu** (Figure 3-152) is displayed.

Figure 3-152: Preset Menu - Typical

```
--- Preset Menu ---
* #1:Preset 1
    Save Settings
    Recall Preset
```

27. Press the Up or Down arrow keys, as required, to select the **> Recall Preset** option.
28. Press the **SEL** key or Right arrow key and observe the **>** cursor changes to a **!** cursor.
29. Press the Up, Down, Right, or Left arrow keys, as required, to select the Preset required and press the **SEL** key.
30. Press the Up arrow key to select the **> Save Settings** option and press the **SEL** key twice.
31. Press the **ESC** key until the Main screen is displayed.

3.9.10 Change IF/RF Operation Mode

The procedure required to change the operation mode from IF to RF or from RF to IF is contained in the following steps.

This procedure allows you to change the IF/RF operation mode

from the MRX4000 PLUS front panel without using the Configurator software. The operation mode may be changed from IF to RF or from RF to IF while retaining the current Preset settings. The changes may also be saved as a specific Preset.

Changing the operation mode from IF to RF or from RF to IF requires additional changes to RF/IF filter settings in the radio. Steps are provided to ensure the proper filter settings required for IF/RF operations are properly set for the applicable operation mode.

If the changes are not saved as a Preset, the new settings will be retained until a Preset is selected. If the MRX4000 PLUS is powered down, the MRX4000 PLUS will retain the new settings, even if the settings were not saved as a Preset. Settings will be retained upon power up. When a new Preset is selected, the new settings will be lost. The steps required to save the new operation mode settings as a Preset are provided in this procedure.

1. Verify the MRX4000 PLUS is powered up.
2. Verify the Main screen (Figure 3-153) is displayed. If the Main screen is not displayed, press the **ESC** key until the Main screen is displayed.

Figure 3-153: Main Screen Menu

```
----- MRX4000+ -----
>> MPEG Settings
    COFDM Settings
    FMR Settings
```

3. Press the Up or Down arrow keys, as required, to move the cursor to the **RF/IF Settings** option. See Figure 3-154 on page 3-64.

Figure 3-154: Main Menu - RF/IF Settings Option

```
----- MRX4000+ -----
      FMR Settings
    >> RF/IF Settings
      System Menu
```

4. Verify the cursor adjacent to the **RF/IF Settings** option is a >> cursor.
5. Press the **SEL** key or the Right arrow key and observe the **RF/IF** menu (Figure 3-155) is displayed.

Figure 3-155: RF/IF Menu - Typical

```
----- RF/IF -----
      Ch: 1
    > Filt: 15MHz LC
      Squelch: Off
```

6. Press the Up or Down arrow keys, as required, to select the > **Source:** option.
7. Press the **SEL** key and observe the > cursor changes to a ! cursor.
8. Press the Up, Down, Left, or Right arrow keys to select **IF** or **RF**, as required, and press the **SEL** key.
9. Press the **ESC** key until the Main screen is displayed.
10. Perform “[Change Filter Setting](#)” on page 3-58, as required, to select the filter setting required.

Notes If the new settings are to be saved as a Preset, go to [step 11](#).

If the settings are not to be saved as a Preset, this procedure is complete.

11. Verify the Main screen (Figure 3-156) is displayed. If the Main screen is not displayed, press the **ESC** key until the Main screen is displayed.

Figure 3-156: Main Screen Menu

```
----- MRX4000+ -----
    >> MPEG Settings
      COFDM Settings
      FMR Settings
```

12. Press the Down arrow key to move the cursor to the Main screen **System Menu** option and press the **SEL** key.
13. Observe the **System Menu** (Figure 3-157) is displayed.

Figure 3-157: System Menu

```
--- System Menu ---
    >> Preset Menu
      Active Errors
      Error Log
```

14. Press the Up or Down arrow keys, as required, to select the >> **Preset Menu** option.
15. Press the **SEL** key and observe the **Preset Menu** (Figure 3-158 on page 3-65) is displayed.

Figure 3-158: Preset Menu - Typical

```

--- Preset Menu ---
* #1:Preset 1
  Save Settings
  Recall Preset
    
```

16. Press the Up or Down arrow keys, as required, to select the > **Recall Preset** option.
17. Press the **SEL** key or Right arrow key and observe the > cursor changes to a ! cursor.
18. Press the Up, Down, Right, or Left arrow keys, as required, to select the Preset required and press the **SEL** key.
19. Press the Up arrow key to select the > **Save Settings** option and press the **SEL** key twice.
20. Press the **ESC** key until the Main screen is displayed.

3.10 Monitor/Change System Menu Options

The procedures listed in [Table 3-7](#) are used to select system Presets, review active errors, review the system error log, observe available system firmware versions, and to perform a system reset.

Table 3-7: Monitor/Change System Settings

Topic	Page	Monitor Only	Change
Monitor/Change Active Preset	3-67		✓
Monitor Active Errors	3-67	✓	
Review Error Log	3-68		✓
Review System Information	3-69	✓	
Perform System Reset	3-70		✓

See [Figure 3-159](#) on page 3-66 for the System Menus Map.

Figure 3-159: System Menu Map

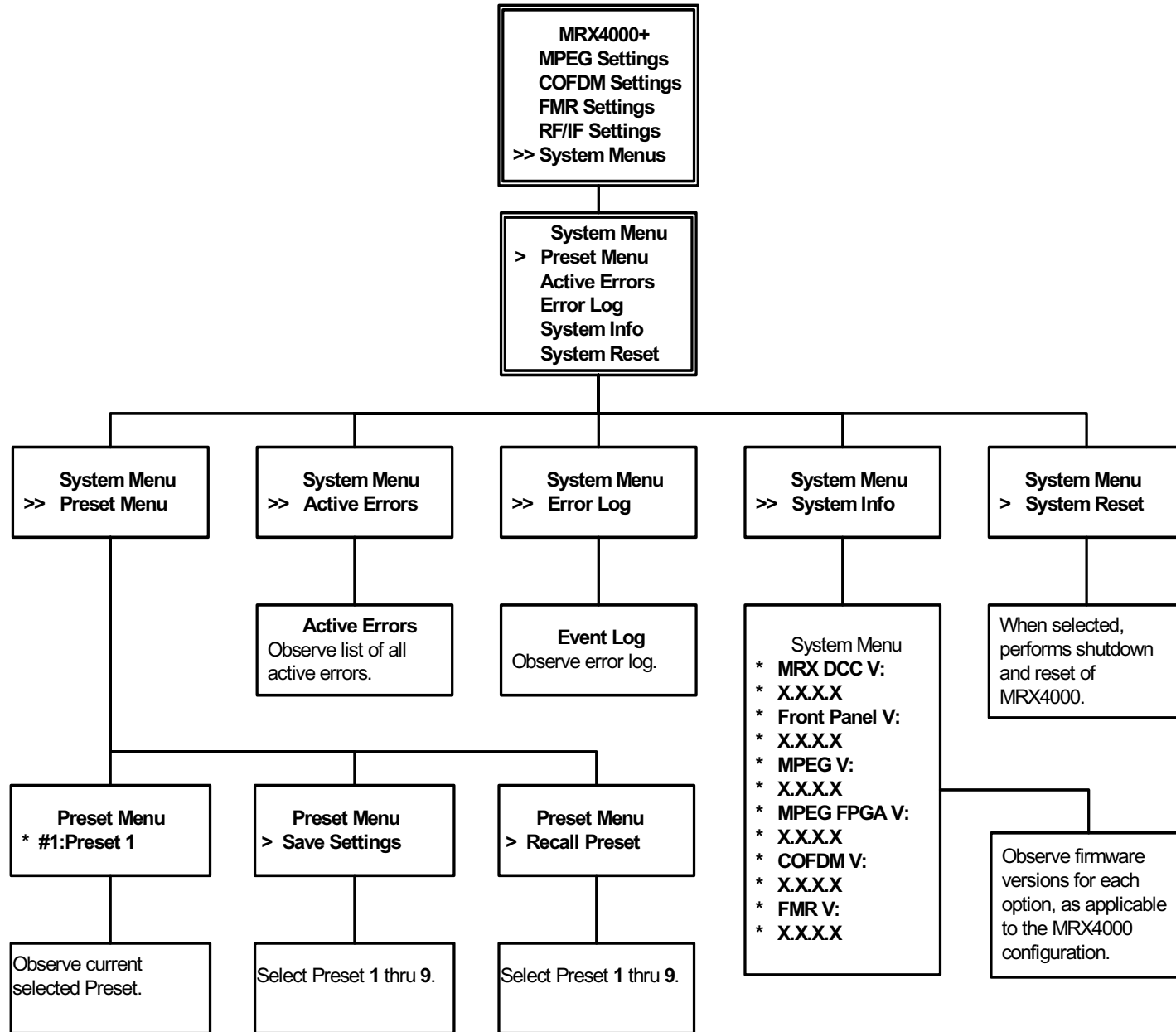

3.10.1 Monitor/Change Active Preset

To monitor/change the current active Preset, perform the following steps:

Notes Prior to selecting Presets in the following steps, you must determine which Preset or Presets have been set for the IF IN MPEG, RF IN MPEG, IF IN Analog, and RF IN Analog operation modes using the Configurator software.

The Preset operation modes should have been recorded when the MRX4000 PLUS was programmed using the Configurator software.

1. Verify the MRX4000 PLUS is powered up.
2. Verify the Main screen (Figure 3-160) is displayed. If the Main screen is not displayed, press the **ESC** key until the Main screen is displayed.

Figure 3-160: Main Screen Menu

```
----- MRX4000+ -----  
>> MPEG Settings  
    COFDM Settings  
    FMR Settings
```

3. Press the Down arrow key to move the cursor to the Main screen **System Menus** option and press the **SEL** key.
4. Observe the **System Menu** (Figure 3-161) is displayed.

Figure 3-161: System Menu

```
--- System Menu ---  
>> Preset Menu  
    Active Errors  
    Error Log
```

5. Press the Up or Down arrow keys, as required, to select the **>> Preset Menu** option.
6. Observe the **Preset Menu** (Figure 3-162) is displayed.

Figure 3-162: Preset Menu - Typical

```
--- Preset Menu ---  
* #1:Preset 1  
    Save Settings  
    Recall Preset
```

7. Press the Up or Down arrow keys, as required, to select the **> Recall Preset** option.
8. Press the **SEL** key or Right arrow key and observe the **>** cursor changes to a **!** cursor.
9. Press the Up, Down, Right, or Left arrow keys, as required, to select the Preset required and press the **SEL** key.
10. Press the **ESC** key until the Main screen is displayed.

3.10.2 Monitor Active Errors

The procedure required to monitor MRX4000 PLUS system active errors is contained in the following steps.

1. Verify the MRX4000 PLUS is powered up.
2. Verify the Main screen (Figure 3-163 on page 3-68) is displayed. If the Main screen is not displayed, press the **ESC** key until the Main screen is displayed.

Figure 3-163: Main Screen Menu

```
----- MRX4000+ -----
>> MPEG Settings
    COFDM Settings
    FMR Settings
```

3. Press the Down arrow key to move the cursor to the Main screen **System Menus** option and press the **SEL** key.
4. Observe the **System Menu** (Figure 3-164) is displayed.

Figure 3-164: System Menu

```
--- System Menu ---
>> Preset Menu
    Active Errors
    Error Log
```

5. Press the Up or Down arrow keys, as required, to select the **>> Active Errors** option.

Note In the following step, if no active errors are present, the message *** No Entries** will be displayed.

6. Press the **SEL** key or Right arrow key and observe the **Active Errors** menu (Figure 3-165) is displayed.

Figure 3-165: Active Errors Menu - Typical

```
-- Active Errors --
* E347:IF Lvl Alm
  E207:FM No Sub 4
  E206:FM No Sub 3
```

7. Press the Up and Down arrow keys, as required, to review the list of current active system errors.
8. Press the **ESC** key until the Main screen is displayed.

3.10.3 Review Error Log

The procedure required to review the system error log is contained in the following steps.

1. Verify the MRX4000 PLUS is powered up.
2. Verify the Main screen (Figure 3-166) is displayed. If the Main screen is not displayed, press the **ESC** key until the Main screen is displayed.

Figure 3-166: Main Screen Menu

```
----- MRX4000+ -----
>> MPEG Settings
    COFDM Settings
    FMR Settings
```

3. Press the Down arrow key to move the cursor to the Main screen **System Menus** option and press the **SEL** key.
4. Observe the **System Menu** is displayed. See Figure 3-167.

Figure 3-167: System Menu

```
--- System Menu ---
>> Preset Menu
    Active Errors
    Error Log
```

5. Press the Up or Down arrow keys, as required, to select the **>> Error Log** option.
6. Press the **SEL** key or Right arrow key and observe the **Event Log** menu (Figure 3-168) is displayed

Figure 3-168: Event Log Menu - Typical

```

----- Event Log -----
> E200:FM Au1 PLL
  E204:FM No Sub1
  E201:FM Au2 PLL
  
```

7. Press the Up and Down arrow keys, as required, to review the list of current active system errors.
8. At any **Event Log** error message, press the **SEL** key or Right arrow key and observe the **Clear Log?** menu (Figure 3-169) is displayed.

Figure 3-169: Clear Log Menu

```

----- Event Log -----
----- Clear Log? -----
>Yes                               No
  
```

Note In the following step, if the **Yes** option is selected, all error messages in the Event Log will be cleared from the log; if the **No** option is selected, no errors will be deleted from the log.

9. Press the Right or Left arrow key, as required, to select **Yes** or **No** and press the **SEL** key.
10. Observe **Event Log** indicates **No Entries** if no errors are currently present in the system. If errors are present in the system, the current errors will be listed.

11. Press the **ESC** key until the Main screen is displayed.

3.10.4 Review System Information

The procedure required to review MRX4000 PLUS system information is contained in the following steps.

1. Verify the MRX4000 PLUS is powered up.
2. Verify the Main screen (Figure 3-170) is displayed. If the Main screen is not displayed, press the **ESC** key until the Main screen is displayed.

Figure 3-170: Main Screen Menu

```

----- MRX4000+ -----
>> MPEG Settings
   COFDM Settings
   FMR Settings
  
```

3. Press the Down arrow key to move the cursor to the Main screen **System Menus** option and press the **SEL** key.
4. Observe the **System Menu** is displayed. See Figure 3-171.

Figure 3-171: System Menu

```

----- System Menu -----
>> Preset Menu
   Active Errors
   Error Log
  
```

5. Press the Up or Down arrow keys, as required, to select the **>> System Info** option.

Notes In the following step, all options for the MRX4000 PLUS will be displayed with their version numbers in the **System Info** menu.

If your MRX4000 PLUS does not contain a specific option, the firmware version will indicate **Not Detected**.

The MRX4000 PLUS menu displays a maximum of three lines of data. For simplicity, [Figure 3-172](#) is shown with all available menu options.

6. Press the **SEL** key or Right arrow key and observe the **System Info** menu ([Figure 3-172](#)) is displayed.
7. Press the Up and Down arrow keys, as required, to review the **System Info** list of firmware versions and the configuration options contained in your MRX4000 PLUS.

Figure 3-172: System Info Menu - Typical

```
System Menu
* MRX DCC V:
* 0.1.0.1
* Front Panel V:
* 0.1.2.0
* MPEG V:
* 0.1.3.0
* MPEG FPGA V:
* 0.1.3.0
* COFDM V:
* 0.3.0.0
* FMR V:
* 0.1.0.2
```

8. Press the **ESC** key until the Main screen is displayed.
-

3.10.5 Perform System Reset

The procedure required to perform a MRX4000 PLUS system reset, in the event of a suspected system crash, is contained in the following steps.

1. Verify the MRX4000 PLUS is powered up.
2. Verify the Main screen ([Figure 3-173](#)) is displayed. If the Main screen is not displayed, press the **ESC** key until the Main screen is displayed.

Figure 3-173: Main Screen Menu

```
----- MRX4000+ -----
>> MPEG Settings
    COFDM Settings
    FMR Settings
```

3. Press the Down arrow key to move the cursor to the Main screen **System Menus** option and press the **SEL** key.
4. Observe the **System Menu** ([Figure 3-174](#)) is displayed.

Figure 3-174: System Menu

```
--- System Menu ---
>> Preset Menu
    Active Errors
    Error Log
```

5. Press the Up or Down arrow keys, as required, to select the **> System Reset** option, press the Right arrow key, and observe the confirmation screen is displayed. [See Figure 3-175 on page 3-71.](#)

Figure 3-175: System Reset Confirmation Screen

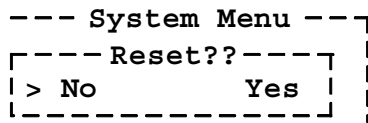

6. Press the Right arrow key to select the **Yes** option, press the **SEL** key, and observe the MRX4000 PLUS powers down momentarily and then re-boots.
7. After a short delay, observe the Main screen is displayed.

3.11 Front Panel vs. Configurator Software

The design of the MRX4000 PLUS and the Configurator software makes commonly available settings accessible from the MRX4000 PLUS front panel and more advanced settings accessible through the Configurator software.

A summary of settings that can be controlled by each method is shown in [Table 3-8](#).

Table 3-8: Front Panel vs. Configurator Settings

Parameter	Available Settings	Set Using Front Panel	Set Using Configurator
<i>MPEG Settings</i>			
Color Bars	ON or OFF	✓	✓
Audio Out	Ana or Dig	✓	
	Analog or ASI/EBU		✓
NTSC Pedestal	ON or OFF	✓	✓
BISS	OFF, BISS-1, or BISS-E	✓	✓
Video Loss	Black or Freeze	✓	
Audio A Stream	MPEG Only		✓
Audio B Stream	MPEG Only		✓
Service Information	On or Off		✓
Service	Preference		✓
	Number		✓

Table 3-8: Front Panel vs. Configurator Settings

Parameter	Available Settings	Set Using Front Panel	Set Using Configurator
COFDM Settings			
Bandwidth	6 MHz, 7 MHz, 8 MHz, or Auto	✓	✓
Radio Settings			
Operation Mode	RF IN Analog, RF IN MPEG, IF IN MPEG, or IF IN Analog		✓
	IF or RF	✓	
	ANALOG or DIGITAL	✓	
Preset Name	(As Required)		✓
IF Filter	<ul style="list-style-type: none"> • NTSC Analog Mode - 10 MHz or 15 MHz • PAL Analog Mode - 15 MHz or 20 MHz • NTSC Digital Mode - 6 MHz, 8 MHz, 10 MHz or 15 MHz • PAL Digital Mode - 6 MHz, 8 MHz, 15 MHz or 20 MHz 	✓	✓

Table 3-8: Front Panel vs. Configurator Settings

Parameter	Available Settings	Set Using Front Panel	Set Using Configurator
Squelch	-65 dB to -95 dB, Squelch, or no Squelch	✓	✓
Band	2.0GHz, 2GHzBAS, 7.0GHz, or 13.0GHz	✓	✓
FMR Settings			
Video Filter	ON or OFF	✓	
Video Deviation	3 MHz or 4 MHz	✓	✓
Low Pass Filter	ON or OFF	✓	✓
Audio Sub-Carrier 1:			
• Filter	ON or OFF	✓	✓
• Deemphasis	ON or OFF	✓	✓
• Frequency	<ul style="list-style-type: none"> • 4830 kHz • 5200 kHz • 5800 kHz • 6200 kHz • 6800 kHz • 7020 kHz • 7500 kHz • 8065 kHz • 8300 kHz • 8590 kHz 	✓	✓

Table 3-8: Front Panel vs. Configurator Settings

Parameter	Available Settings	Set Using Front Panel	Set Using Configurator
Audio Sub-Carrier 2:			
• Filter	ON or OFF	✓	✓
• Deemphasis	ON or OFF	✓	✓
• Frequency	<ul style="list-style-type: none"> • 4830 kHz • 5200 kHz • 5800 kHz • 6200 kHz • 6800 kHz • 7020 kHz • 7500 kHz • 8065 kHz • 8300 kHz • 8590 kHz 	✓	✓
Audio Sub-Carrier 3:			
• Filter	ON or OFF	✓	✓
• Deemphasis	ON or OFF	✓	✓
• Frequency	<ul style="list-style-type: none"> • 4830 kHz • 5200 kHz • 5800 kHz • 6200 kHz • 6800 kHz • 7020 kHz • 7500 kHz • 8065 kHz • 8300 kHz • 8590 kHz 	✓	✓

Table 3-8: Front Panel vs. Configurator Settings

Parameter	Available Settings	Set Using Front Panel	Set Using Configurator
Audio Sub-Carrier 4:			
• Filter	ON or OFF	✓	✓
• Deemphasis	ON or OFF	✓	✓
• Frequency	<ul style="list-style-type: none"> • 4830 kHz • 5200 kHz • 5800 kHz • 6200 kHz • 6800 kHz • 7020 kHz • 7500 kHz • 8065 kHz • 8300 kHz • 8590 kHz 	✓	✓
LP Filter	ON or OFF	✓	✓
Channel Plan			
• Channel	<ul style="list-style-type: none"> • 2 GHz Band - Channel 1 thru Channel 10 • 2 GHz BAS Band - Channel 1 thru 10 • 7 GHz Band - Channel 1 thru 14 • 13 GHz band - Channel 1 thru 22 	✓	✓

Table 3-8: Front Panel vs. Configurator Settings

Parameter	Available Settings	Set Using Front Panel	Set Using Configurator
<ul style="list-style-type: none"> • Offset 	<ul style="list-style-type: none"> • 2 GHz Band - Minus (-), Center, or Plus (+) • 2 GHz BAS Band - Minus (-), Center, or Plus (+) • 7 GHz Band - Minus (-), Center, or Plus (+) • 13 GHz Band - Minus (-), Center, Plus (+) or Plus Plus (++) 	✓	✓
	Modify Offset Frequencies		✓

4 Troubleshooting

4.1 Chapter Overview

This chapter describes how to troubleshoot your MRX4000 PLUS High Performance Analog + Digital Integrated Receiver Decoder (IRD) (MRX4000 PLUS).

Here are the topics covered:

Topic	Page
Status LEDs	4-1
Error Codes	4-2

4.2 Status LEDs

The MRX4000 PLUS front panel contains three status LEDs. The LED indications are listed in [Table 4-1](#).

Table 4-1: Status LED Indications

LED	Meaning	Suggested Action
POWER Off	Power is not on in the unit.	<ul style="list-style-type: none"> • Turn on power switch, as required. • Turn on power source, as required. • Check and replace fuse, as required.
POWER Green	Power is on.	None.
ALERT Amber	Minor Alarm - Power is on but some part of the system reports an abnormal condition that requires attention. Condition might impair performance.	Check alphanumeric display System Menu > Active Errors menus for error messages or error codes. Troubleshoot using tables in this chapter.
ALARM Red	Major Alarm - Power is on but there is a serious failure or error that will prevent normal operation.	Check alphanumeric display System Menu > Active Errors menus for error messages or error codes. Troubleshoot using tables in this chapter.

4.3 Error Codes

The MRX4000 PLUS has an extensive library of diagnostic error codes to help you pinpoint any problems.

The error codes are displayed on the MRX4000 PLUS front panel alphanumeric display, on the **System Menus > Active Errors** menu screen. See [Figure 4-1](#).

Figure 4-1: System Menus > Active Errors Display - Typical

```
┌── Active Errors ──┐
│ * E207:FM No Sub4 │
│   E206:FM No Sub3 │
│   E205:FM No Sub2 │
└──────────────────┘
```

These error codes will cause the MRX4000 PLUS front panel **ALERT** LED to glow amber or the **ALARM** LED to glow red, alerting you to investigate the problem.

The error codes are also displayed on the **MRX4000 Plus Configuration Utility** (Configurator) software **Monitor Errors** tab when the MRX4000 PLUS is connected to the Configurator via an RS-232 link. See [Figure 4-2](#).

Figure 4-2: Configurator Monitor Errors Tab - Typical

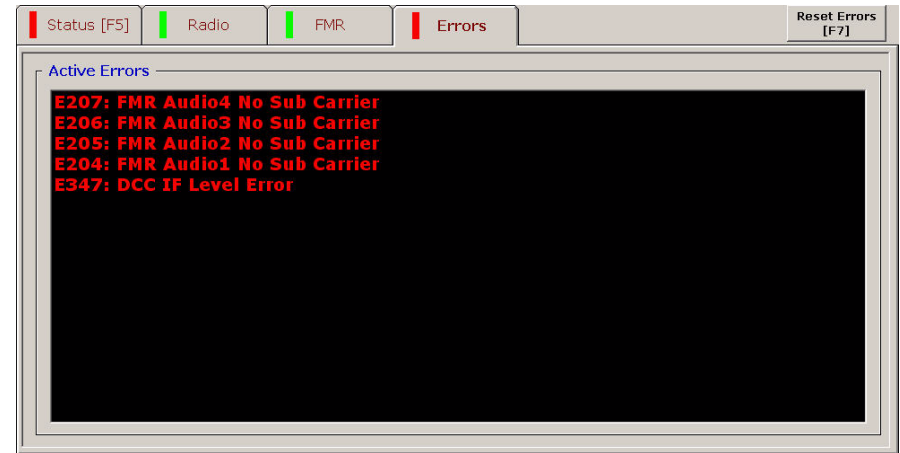

The first group of characters is the primary error code, i.e., **E207**. In all cases this portion of the error code will uniquely identify the problem by providing an error message label adjacent to the error code, i.e., **FM No Sub4**.

See [Table 4-2 on page 4-3](#) for descriptions of the error codes and what to do when they appear.

Table 4-2: Primary Error Codes

Error Code	Meaning	Suggested Operator Action	Suggested Technical Staff Action
Status Errors <i>(MPEG/COFDM portion of System is reporting an abnormal condition.)</i>			
E120	MPEG Transport Lock Fault	<i>Note - These errors will appear only if the MRX4000 PLUS contains the COFDM/ MPEG option.</i> <ul style="list-style-type: none"> • Verify condition of cable connections. • Contact technical staff 	If problem persists, possible hardware failure. Contact MRC Technical Support.
E121	MPEG Video Lock Fault		
E122	MPEG PCR Lock Fault		
Status Errors <i>(FMR portion of System is reporting an abnormal condition.)</i>			
E200	FMR Audio 1 PLL Unlock Fault	<i>Note - These errors will appear only if the MRX4000 PLUS contains the FMR option.</i> <ul style="list-style-type: none"> • Verify condition of cable connections. • Contact technical staff 	If problem persists, possible hardware failure. Contact MRC Technical Support.
E201	FMR Audio 2 PLL Unlock Fault		
E202	FMR Audio 3 PLL Unlock Fault		
E203	FMR Audio 4 PLL Unlock Fault		
E204	FMR Audio 1 No Sub-carrier Fault		
E205	FMR Audio 2 No Sub-carrier Fault		
E206	FMR Audio 3 No Sub-carrier Fault		
E207	FMR Audio 4 No Sub-carrier Fault		
Parameter Errors <i>(Some internal parameter is outside of allowable limits.)</i>			
E340	DCC 5.5 Volt Line Fault	<ul style="list-style-type: none"> • Contact technical staff. 	If problem persists, possible hardware failure. Contact MRC Technical Support.
E341	DCC 5 Volt Line Fault		
E342	DCC +12 Volt Line Fault		
E343	DCC -12 Volt Line Fault		
E344	DCC 24 Volt Line Fault		

Table 4-2: Primary Error Codes (Continued)

Error Code	Meaning	Suggested Operator Action	Suggested Technical Staff Action
E345	DCC Temperature Fault	<ul style="list-style-type: none"> • Verify MRX4000 PLUS internal fans are operating. • Check MRX4000 PLUS to be certain it is not too close to sources of heat. Relocate unit, if possible. • Verify MRX4000 PLUS has room around it for proper air flow. Move objects preventing proper air flow. • Contact technical staff. 	If problem persists, possible hardware failure. Contact MRC Technical Support.
E346	DCC Fan Overcurrent Fault	<ul style="list-style-type: none"> • Confirm all fans are operating. • Contact technical staff. 	If problem persists, possible hardware failure. Contact MRC Technical Support.
E347	DCC IF Level Fault	<ul style="list-style-type: none"> • Verify all system cables are properly connected. • Verify all system inputs are present. • Contact technical staff. 	If problem persists, possible hardware failure. Contact MRC Technical Support.
E348	DCC RSSI Fault		

A Glossary

This section describes acronyms and abbreviations used in communications, broadcasting, and in our products and documentation.

Table A-1: Useful Terms

Term	Explanation
1RU	1 Rack Unit (1.75 inches in height)
1080i	1080i is a standard HDTV video mode. 1080 represents 1080 lines of vertical resolution and the letter <i>i</i> represents “interlaced” or non-progressive scan. 1080i usually assumes a wide screen aspect ratio of 16:9, implying a horizontal resolution of 1920 pixels and a frame resolution of 1920 x 1080, or 2.07 million pixels.
16QAM	16-state Quadrature Amplitude Modulation The signal (video + audio) is imposed onto the 70 MHz carrier by varying both the phase and the amplitude of the signal while keeping the frequency constant. There are 16 possible combinations of phase and amplitude that can be used to carry information.
2 FSK	2-state Frequency Shift Keying
2RU	2 Rack Unit (3.5 inches in height)
3RU	3 Rack Unit (5.25 Inches in height)

Table A-1: Useful Terms (Continued)

32QAM	32-state Quadrature Amplitude Modulation The signal (video + audio) is imposed onto the 70 MHz carrier by varying both the phase and the amplitude of the signal while keeping the frequency constant. There are 32 possible combinations of phase and amplitude that can be used to carry information.
4 FSK	4-state Frequency Shift Keying
8 PSK	8-Phase Shift Keying
8QAM	8-state Quadrature Amplitude Modulation The signal (video + audio) is imposed onto the 70 MHz carrier by varying both the phase and the amplitude of the signal while keeping the frequency constant. There are 8 possible combinations of phase and amplitude that can be used to carry information.
64QAM	64-state Quadrature Amplitude Modulation The signal (video+audio) is imposed onto the 70 MHz carrier by varying both the phase and the amplitude of the signal while keeping the frequency constant. There are 64 possible combinations of phase and amplitude that can be used to carry information.
720p	720 represents 720 lines of vertical resolution and the letter <i>p</i> represents non-interlaced or progressive scan. When broadcast at 60 frames per second, 720p features the highest temporal (motion) resolution possible under the ATSC standard. Progressive scanning reduces the need to prevent flicker by filtering out fine details, so spatial (sharpness) resolution is much closer to 1080i than the number of scan lines would suggest.

Table A-1: Useful Terms (Continued)

A & C	Alarm and Control
ACU	AC to DC Converter Unit
ADPCM	Adaptive Differential Pulse Code Modulation
AES	Audio Engineering Society
AES/EBU	Unofficial name for a digital audio standard developed as a joint enterprise of the AES and the EBU.
AFC	Automatic Frequency Control
AGC	Automatic Gain Control
AIS	Alarm Indication Signal (all one's)
AMI	Alternate Mark Inversion, line code format for traffic data.
AVG	Average
ASI	Asynchronous Serial Interface A serial communications interface operating up to 270 Mbit/sec. Generally used in field news-gathering operations.
ASYNCR	Asynchronous Digital communication in which there is no timing requirement for transmission and in which the start of each character is individually signaled by the transmitting device.
ATSC	Advanced Television Systems Committee The group that developed the ATSC digital television standard for the US and other countries.

Table A-1: Useful Terms (Continued)

Baseband	A composite signal in which video and audio signals are combined together, with video occupying approximately 0-4.5 MHz and audio modulated onto subcarriers in the 5-6 MHz range.
BB	Baseband
BDC	Block Downconverter
BER	Bit Error Ratio The Bit Error Rate is the percentage of bits that have errors relative to the total number of bits in the signal. The rate is an indication of how often a packet or other data unit has to be retransmitted because of an error.
BiasT	A type of interconnection between the IDU and the ODU. In Bias T wiring, IF and DC are combined and carried on the coax cable up the ODU; blocking circuitry prevents the DC from entering the IDU.
BISS	Basic Interoperable Scrambling System A means of encrypting and decrypting a digital signal to prevent unauthorized reception. The encryption and decryption are controlled by a digital key, which is shared at both the transmitting and receiving location.
BISS-1	BISS encryption that uses a fixed key.
BISS-E	BISS encryption that uses an encrypted key.
BNC	Bayonet lock coaxial connector
BPF	Band Pass Filter
bps or b/sec	Bits per second
BPSK	Binary Phase Shift Keying
BW	Bandwidth

Table A-1: Useful Terms (Continued)

CCITT	International Telegraph and Telephone Consultative Committee A telecommunications standardizing committee of the ITU.
CCPS	Command & Control Power Supply
CENELEC	European Committee for Electrotechnical Standardization
CNR	Carrier-to-Noise Ratio
COFDM	Coded Orthogonal Frequency Division Multiplexing
Composite (Baseband)	A band or grouping of frequencies and/or subcarriers, including video, occupied by the signal in a radio transmission system. Also called Baseband.
Co-channel interference	Interference caused by two video transmitters broadcasting on the same channel of the same frequency (for example, on channel 2 in the 2 GHz band).
CR4	Code Runner 4
Crossover cable	A Category 5 (CAT5) network cable used to connect two computers. The cable crosses over (reverses) pins 1 and 3 and pins 2 and 6 of the cable's RJ-45 connectors. The transmitter (TX) pins are therefore connected to the corresponding receiver (RX) pins, plus to plus and minus to minus.
CSI	Channel-State Information
CV	Composite Video Video signal in which the chrominance (color) and luminance (brightness) information are combined in one signal. S-Video separates the chrominance and luminance into individual signals.
CW	Carrier Wave

Table A-1: Useful Terms (Continued)

DAB	Digital Audio Broadcasting
dB	Decibel A logarithmic measurement of power or voltage, applied to audio and RF signals.
dBm	A measure of RF signal strength defined as “decibels relative to one milliwatt (mW).” A 1 mW signal has a signal strength of 0 dBm. A signal weaker than 1 mW has a negative dBm value, and a signal stronger than 1 mW has a positive dBm value.
DCC	Distribution Command and Control
DCE	Data Communications Equipment A device that communicates with a DTE device. In practical terms, the DCE is usually a modem and the DTE device is usually a computer.
De-emphasis	Reducing the amplitude of high frequency components of an analog audio signal. Done on the receive end of an analog link to take out emphasis added on the transmit side.
DFT	Discrete Fourier Transform
DHCP	Dynamic Host Configuration Protocol A protocol for automating the configuration of computers that use TCP/IP.
DMUX, DEMUX	Demultiplexer
DQPSK	Differential Quadrature (Quaternary) Phase-Shift Keying
DRL	Data Return Link

Table A-1: Useful Terms (Continued)

DS3	Digital Signal 3 44.736 Mbps data rate.
DTE	Data Terminal Equipment A device that communicates with a DCE device. In practical terms, the DTE is usually a computer and the DCE device is usually a modem.
Duplex	A channel capable of transmitting information simultaneously in both directions.
DVB	Digital Video Broadcasting
DVB-ASI	Digital Video Broadcasting - Asynchronous Serial Interface A widely-used MPEG-2 digital transport interface. Physically the connection is made either with optical fiber or 75 ohm coax with a BNC connector. Interface can support data rates up to 270 Mb/sec.
DVB-C	Digital Video Broadcasting - Cable
DVB-S	Digital Video Broadcasting - Satellite
DVB-T	Digital Video Broadcasting - Terrestrial
E1	2.048 Mbps data rate.
E3	34.368 Mbps data rate
EIA	Electronic Industries Association An industry association that establishes various standards.
EBU	European Broadcasting Union In addition to other activities, EBU produces technical statements and recommendations for PAL television systems.

Table A-1: Useful Terms (Continued)

EMC	Electromagnetic compatibility.
Emphasis	Boosting the amplitude of high frequency components of an analog audio signal. Done on the transmit side of an analog link to improve signal-to-noise ratio.
ENG	Electronic News Gathering
ERRS	Errors
ESD	Electrostatic Discharge
ET	Eastern Time (US)
ETSI	European Telecommunications Standards Institute
EVM	Error Vector Magnitude
FCC	Federal Communications Commission The United States communications regulatory agency.
FDM	Frequency Division Multiplexing
FEC	Forward Error Corrections
FFT	Fast Fourier Transform
FIFO	First In, First Out buffer
FIR	Finite Impulse Response
FMT	FM Video Modulator or FM Transmitter
FPGA	Field Programmable Gate Array
FSK	Frequency-Shift Keying
FTP	File Transfer Protocol
FW	Firmware
GHz	Gigahertz (10 ⁹ Hz)
GI	Guard Interval
GND	Ground

Table A-1: Useful Terms (Continued)

GPS	The Global Positioning System is a set of 24 satellites that are in 10,600-mile orbits above the Earth. Owned and operated by the U.S. Department of Defense, GPS enables people with ground receivers to pinpoint their geographic location.
GUI	Graphic User Interface
Hashed	A visual cue on a graphical user interface consisting of diagonal lines across the surface of a button. This indicates that a button is not currently functional.
HD	High Definition (video)
HDB3	High Density Bipolar 3 line code format for traffic data.
HD-SDI	High Definition Serial Data Interface A serial communications interface operating at 1.5 Gbit/sec.
HPF	High Pass Filter
HPU	High Power Unit
H/W or HW	Hardware
Hz	Hertz Hz is a unit of frequency of one cycle per second. Hz replaces the earlier term of "cycles per second" (CPS).
ICI	Inter-Carrier Interference
ICR	Inter-City Relay
ID	Identification
IDU	Indoor Unit
IF	Intermediate Frequency
IMD	Inter-Modulation Distortion

Table A-1: Useful Terms (Continued)

I/O	Input/Output
IP Address	An Internet Protocol (IP) address is a 32-bit number (for example, 123.45.67.89 for IP version 4) or a 128-bit number (for IP version 6) that identifies the network device that is sending or receiving information that is transmitted across a local area network (LAN) or the Internet.
IRD	Integrated Receiver Decoder
IRE	1. Institute of Radio Engineers, an international professional radio engineering association that establishes various standards. 2. A unit of measurement, established by the IRE, in which 1 IRE Unit = .00714 volts peak-to-peak (Vp-p) and 140 IRE units equals 1 Vp-p.
ISI	Inter-Symbol Interference
ISO	International Standards Organization
Kbps	Kilobits per second
KHz	Kilo (1,000) Hz
LAN	Local Area Network
LBO	Line Build Out
LCD	Liquid Crystal Display
Lcl	Local
LED	Light Emitting Diode
LIU	Line Interface Unit
LMS-T	Link® Modulation System - Terrestrial A proprietary algorithm system for modulation.
LNA	Low Noise Amplifier
LNB	Low Noise Block Downconverter
LNC	Low Noise Converter

Table A-1: Useful Terms (Continued)

LO	Local Oscillator
LOS	Loss of Signal
LPF	Low Pass Filter
LQ	Link Quality
MAC Address	The Media Access Control (MAC) address is a unique identification number for a network device on a local area network (LAN) or other network. This number (a physical address such as 00-A1-B2-C3-D4-5F) is stored in the device's network adapter and is used to acquire an IP address for the device.
MaxRC	Maximal Ratio Combining
Mbps	Megabits per second
MER	Modulation Error Ratio Modulation error ratio is a measure used to quantify the performance of a digital radio transmitter or receiver using digital modulation, such as QAM.
MHz	Million (1,000,000) Hz
MPEG	Moving Picture Experts Group
M-QAM	M-order of Quadrature Amplitude Modulation
MRC	Microwave Radio Communications
Multipath	An unpredictable set of reflections and/or direct waves, each with its own degree of attenuation and delay. Due to obstacles and reflectors in the signal's path, transmitted signals arrive at the receive antenna from various directions over multiple paths at slightly different times.
MUX	Multiplexer
NC	Normally Closed (Relay or switch contacts)
N/C	No Connection

Table A-1: Useful Terms (Continued)

NICAM	Near-Instantaneous Companding and Multiplexing
NO	Normally Open (Relay or switch contacts)
NRZ	Non-Return-to-Zero (Modulation)
NTSC	National Television System Committee Color television standard used in the US. Provides 525 horizontal lines of resolution. Not compatible with PAL or SECAM.
Null modem cable	An RS-232 cable designed to connect two computers (or other data sources) together. It has male DB9 connectors on each end, to mate with the DB9 female connectors on the PCs. With a null modem connection, the transmit and receive connections are crosslinked so that transmit (pin 3) on one end connects to the receive (pin 2) on the other. The term can also be applied to similar Ethernet cables. Also called a "Crossover Cable".
OB	Outside Broadcast
ODU	Outdoor Unit
OFDM	Orthogonal Frequency Division Multiplexing
OOK	On-Off Keying
PA	Power Amplifier
PAL	Phase Alternation Line Color television standard used in many European countries. Provides 625 horizontal lines of resolution. Not compatible with NTSC or SECAM.

Table A-1: Useful Terms (Continued)

PAL-M	Phase Alternation Line Color television standard used in many European countries. Provides 625 horizontal lines of resolution with 50 lines per field. Not compatible with NTSC or SECAM.
PAL-N	Phase Alternation Line Color television standard used in many European countries. Provides 525 horizontal lines of resolution with 60 lines per field. Not compatible with NTSC or SECAM.
PC	Personal Computer
PCR	Program Clock Reference
PCS	Personal Communication Services, for example, for cell phones and beepers.
PER	Parity Error Rate
ØLK	Phase Lock
PID	Program Identification
PLL	Phase Lock Loop
POTS	Plain Old Telephone System. Refers to standard analog phone service sometimes used as a back up method for communications.
PRBS	Pseudo Random Bit Sequence
QAM	Quadrature Amplitude Modulation

Table A-1: Useful Terms (Continued)

QPSK	Quadrature Phase Shift Keying The signal (video+audio) is imposed onto the 70 MHz carrier by varying the phase of the signal while keeping the amplitude and frequency constant. There are 4 possible values of phase that can be used to carry information.
RCL	Received Carrier Level The strength of a received RF signal in dBm.
RCU	Receiver Control Unit
Rcvr	Receiver
RD	Receive Data
RDS	Radio Data System
RF	Radio Frequency
RF Level	RF Power from the transmitter.
RFU	Radio Frequency Unit
RMA	Return Material Authorization
RPU	Remote Pickup
R-S	Reed-Solomon
RSSI	Receiver Signal Strength Indicator
RX	Receiver

This page intentionally left blank.

B Channels & Frequencies

B.1 Appendix Overview

This Appendix presents the channels and frequencies that were programmed into your MRX4000 PLUS High Performance Analog + Digital Integrated Receiver Decoder (IRD) (MRX4000 PLUS) at the factory. It also provides the frequencies set by the latest US frequency reallocation plan.

Here are the topics covered:

Topic	Page
Initial Factory Presets	B-1
US 2 GHz Reallocation - 12 MHz Channel Plan	B-2

B.2 Initial Factory Presets

This section lists the channels and frequencies for each RF band covered by the MRX4000 PLUS. These frequencies are preset at the factory, but can be modified using the **MRX4000 Plus Configuration Utility** software.

Note	These frequency settings should only be changed by qualified technical personnel.
-------------	---

Contact the Society of Broadcast Engineers (SBE) coordinator for up-to-date information on local frequency plans for Electronic News Gathering (ENG) and Remote Pickup (RPU) operations.

The channel plan for the 1.9 to 2.5 GHz MRX4000 PLUS is contained in [Table B-1](#).

Table B-1: 2 GHz Channel Plan - 4.25 MHz Offset

Channel	(-) Offset (MHz)	(0) Center (MHz)	(+) Offset (MHz)
1	1994.750	1999.000	2003.250
2	2012.250	2016.500	2020.750
3	2029.250	2033.500	2037.750
4	2046.250	2050.500	2054.750
5	2063.250	2067.500	2071.750
6	2080.250	2084.500	2088.750
7	2097.250	2101.500	2105.750
8	2454.250	2458.500	2462.750
9	2471.250	2475.500	2479.750
10	2487.750	2492.000	2496.250

B.2.1 6.4 to 7.1 GHz Channel Plan

The channel plan for the 6.4 to 7.1 GHz MRX4000 PLUS is contained in [Table B-2](#).

Table B-2: 6.4 to 7.1 GHz Channel Plan

Channel	(-) Offset (MHz)	(0) Center (MHz)	(+) Offset (MHz)
1	6881.250	6887.500	6893.750
2	6906.250	6912.500	6918.750
3	6931.250	6937.500	6943.750
4	6956.250	6962.500	6968.750

Table B-2: 6.4 to 7.1 GHz Channel Plan

Channel	(-) Offset (MHz)	(0) Center (MHz)	(+) Offset (MHz)
5	6981.250	6987.500	6993.750
6	7006.250	7012.500	7018.750
7	7031.250	7037.500	7043.750
8	7056.250	7062.500	7068.750
9	7081.250	7087.500	7093.750
10	7106.250	7112.500	7118.750
11	6431.250	6437.500	6443.750
12	6456.250	6462.500	6468.750
13	6481.250	6487.500	6493.750
14	6511.250	6512.500	6518.750

B.2.2 12.7 to 13.25 GHz Channel Plan

The channel plan for the 12.7 to 13.25 GHz MRX4000 PLUS is contained in [Table B-3](#).

Table B-3: 12.7 to 13.25 GHz Channel Plan

Channel	(-) Offset (MHz)	(0) Center (MHz)	(+) Offset (MHz)	(++) Offset (MHz)
1	12706.250	12712.500	12718.750	12725.000
2	12731.250	12737.500	12743.750	12750.000
3	12756.250	12762.500	12768.750	12775.000
4	12781.250	12787.500	12793.750	12800.000
5	12806.250	12812.500	12818.750	12825.000
6	12831.250	12837.500	12843.750	12850.000
7	12856.250	12862.500	12868.750	12875.000

Table B-3: 12.7 to 13.25 GHz Channel Plan

Channel	(-) Offset (MHz)	(0) Center (MHz)	(+) Offset (MHz)	(++) Offset (MHz)
8	12881.250	12887.500	12893.750	12900.000
9	12906.250	12912.500	12918.750	12925.000
10	12931.250	12937.500	12943.750	12950.000
11	12956.250	12962.500	12968.750	12975.000
12	12981.250	12987.500	12993.750	13000.000
13	13006.250	13012.500	13018.750	13025.000
14	13031.250	13037.500	13043.750	13050.000
15	13056.250	13062.500	13068.750	13075.000
16	13081.250	13087.500	13093.750	13100.000
17	13106.250	13112.500	13118.750	13125.000
18	13131.250	13137.500	13143.750	13150.000
19	13156.250	13162.500	13168.750	13175.000
20	13181.250	13187.500	13193.750	13193.750
21	13206.250	13212.500	13218.750	13218.750
22	13231.250	13237.500	13243.750	13243.750

B.3 US 2 GHz Reallocation - 12 MHz Channel Plan

Here are the frequencies that will be used on the 2 GHz band in the new US 12 MHz channel plan. Your MRX4000 PLUS is pre-programmed with the frequencies listed in [Table B-4 on page B-3](#).

As your station migrates to the new channel plan, you can easily reprogram your MRX4000 PLUS using the Configurator software.

Information below was obtained from the FCC Web site,
document # FCC 03-280:

http://hraunfoss.fcc.gov/edocs_public/attachmatch/FCC-03-280A1.pdf

Table B-4: 2 GHz Band - US 12 MHz Channel Plan

Channel	(-) Offset (MHz)	(0) Center (MHz)	(+) Offset (MHz)
1	2028.500	2031.500	2034.500
2	2040.500	2043.500	2046.500
3	2052.500	2055.500	2058.500
4	2064.500	2067.500	2070.500
5	2076.500	2079.500	2082.500
6	2088.500	2091.500	2094.500
7	2100.500	2103.500	2106.500
8	2454.250	2458.500	2465.750
9	2471.250	2475.500	2479.750
10	2487.750	2492.000	2496.250

This page intentionally left blank.

C **MRX4000 PLUS** **Specifications**

This section provides specifications for the MRX4000 PLUS High Performance Analog + Digital Integrated Receiver Decoder (IRD) (MRX4000 PLUS).

Note MRC reserves the right to make changes to specifications of products described in this specification sheet at any time without notice and without obligation to notify any person of such changes.

GENERAL

Band Operation: Dual 2/7 GHz

Frequency Bands: 1.99 to 2.5 GHz / 2.3 to 2.7 GHz
6.4 to 7.1 GHz (requires external LNC)

RF Input Range: –15 dBm to –95 dBm

IF Outputs: 900 MHz

IF/AGC Level Output: +0 dBm (±1 dB) – Analog
–10 dBm (±1 dB) – Digital

Stability (RF-IF): ± 2.5 ppm

Standard IF Filter Bandwidths:

	<u>NTSC</u>	<u>PAL</u>
1)	6 MHz	6 MHz
2)	8 MHz	8 MHz
3)	10 MHz	15 MHz
4)	15 MHz	20 MHz

IF Linearity (IMR): >40 dB @ 70 MHz

Squelch Adjust: ON/OFF
Level (25 dB from threshold)

ANALOG AUDIO & VIDEO DEMODULATOR

IF Input: 70 MHz

Level Input: (0 dBm to –2 dBm) 0 dBm nominal

Impedance: 75 ohms

Composite Outputs: Switched (Baseband/video)

Video Output: 1 Vpp (75 ohms) 525 /625 line

Return Loss: >26 dB

Video Low Pass Filters: 4.2 , 5.0, or 5.5 MHz

Video Response: ±0.25 dB @ within video
filter bandwidth

VIDEO PERFORMANCE

(with CR4 15MHz Filter)

Signal/Noise: >68 dB (weighted per RS-250C)

Signal/Hum: >63 dB (weighted per RS-250C)

Differential Phase: 1 degree

Differential Gain: 1%

Chroma/Luminance Gain: 4%

Chroma/Luminance Delay: ±20 nS

Field Tilt: 1%

Output Level:

Baseband Response: 10 KHz to 8 MHz +0.5 dB
8 MHz to 12 MHz < 2dB

Audio Channels: . . . Demodulation of 4 Independent Subcarriers

Subcarrier Frequency:

Input tune range: 4.5 MHz to 8.59 MHz tunable in 5
Khz steps (local/serial control)

AUDIO PERFORMANCE

Frequency Response: (40 Hz to 15 KHz): ± 1.0 dB
(40 Hz to 10 KHz): ± 0.5 dB

THD: 0.5 % @ 1 KHz (75 KHz deviation)
2.0 % @ 1 KHz (200KHz deviation)

Signal/Noise: 68 dB (min.)

Output Impedance: 600 ohms balanced

Output Level (adjust): +8 dBm – line level – nominal
(0 dBm to +18 dBm) – local/serial

Audio Channel Crosstalk: 60 dB

De-emphasis: 50 uS/75 uS , flat

CODFM DEMODULATION

IF Input: 70 MHz

Input Range: –10 dBm nom.l, (–10 dBm to –20 dBm)

Bandwidth (Selectable): 6 MHz, 7 MHz, 8 MHz

Threshold: C/N-within 2 dB of ET51 300 744 Std.

COFDM Acquisition Speed: 100 mSec (typical)

Modulation Type: QPSK, 16QAM, 64QAM

Output: ASI

Packet Length: 188 bytes

Forward Error Correction (FEC)-Auto Detect: 1/2, 2/3,
3/4, 5/6, 7/8

Guard Intervals-Auto Detect: 1/32, 1/16, 1/8, 1/4

MPEG DECODER

Output: SDI, Composite Video

Chroma Profile: 4:2:2 / 4:2:0

Line Standard: 525/625

GOP Structures: Variable GOP

Horizontal Resolution: 720, 704, 544, 352

Selectable Vertical Resolution: 576 (625 line), 480 (525 line)

Bit rates: 4:2:0 – 1.5 Mbits – 15 Mbits
4:2:2 – 2.0 Mbits – 50 Mbits

Decoding Type: MPEG II layer 2

Bit Rates: 384 K/Stereo Pair

Sampling: 48 KHz

Composite Video Output: NTSC (w/wo pedestal)/PAL

WAYSIDE CHANNEL

Embedded data channel on MPEG Module:
(uses the RS-232 port for DCE Data Path)

Supported Data Rates: . . 1200, 2400, 4800, 9600, 19200, 38400

PHYSICAL

Weight: 7.0 lbs (3.2 kg)

Operating Temperature Range: –10° C to +50° C

Operating Relative Humidity: 95% @+10° C to +40°

Operating Altitude: . . 15,000 feet above sea level (4,572 meters)

CONNECTIONS

Video Output: BNC

Video Monitor:	BNC
Baseband Output:	BNC
Audio (4 Channels):	3-pin Weidmuller
ASI Output:	BNC
SDI Output:	BNC
900 MHz Monitor Output:	BNC
Wayside Channel:	9-pin "D"
IF Input:	BNC
RF Input:	"N" Type
IF Output:	BNC
Remote and LQ/RCL:	RJ45
Summary Alarm:	9-pin "D"
+24 Vdc Output @ 100mA:	2-pin Weidmuller
Configurator (front panel):	9-pin "D"

FRONT PANEL CONTROLS & DISPLAYS

Selection Buttons:	SEL (Select), ESC (Escape)
Navigation Buttons:	Left ,Right, Up, and Down
LEDs	Power, Alert, and Alarm
LCD Display	4 line

POWER REQUIREMENTS

AC Input:	90 to 264 VAC, 47 to 63 Hz
DC Input:	<u>±</u> 24 VDC to <u>±</u> 48 VDC
Power Connector:	IEC320-C14
DC Power Connector:	2-Pin Weidmuller
Power Consumption:	26 Watts

This page intentionally left blank.

Index

Symbols

+24 VDC fuse	3-5, 3-7
+24V Connector	3-5, 3-7

Numerics

1080i	A-1
12.7 to 13.25 GHz Channel Plan	B-2
16QAM	A-1
6.4 to 7.1 GHz Channel Plan	B-1
64 QAM	A-1
720p	A-1
8 PSK	A-1
900 MHZ connector	3-4, 3-6

A

About This Manual	Notices-i
AC power connector and fuse	3-3, 3-5
AES	A-2
AES/EBU	A-2
ALARM LED	3-2
ALERT LED	3-2
Alphanumeric Display	3-2
alphanumeric display	3-8
ASI	A-2
ASI OUT Connector	3-5
Audience, Intended	1-2
AUDIO 1 thru 4 Connectors	3-5, 3-7

B

BB OUT Connector	3-4, 3-6
BER	A-2

BISS	A-2
BISS 1	A-2
BISS-E	A-2
BNC	A-2

C

Calling for Service	1-3
CAUTIONS	Notices-ii
Channels and Frequencies	B-1
Initial Factory Presets	B-1
US 12MHz Plan	B-2
COFDM	A-3
COFDM Settings	
Monitor COFDM Metrics	3-35
Monitor Forward Error Correction	3-32
Monitor Guard Interval status	3-34
monitor Modulator Type	3-31
Monitor/change Bandwidth	3-30
monitor/change parameters/settings	3-28
Composite Video	A-3
Configurations	
FMR NTSC	2-2
FMR PAL	2-2
MPEG/COFDM	2-2
MPEG/COFDM/FMR NTSC	2-2
MPEG/COFDM/FMR PAL	2-2
Configurator Settings	3-71
CONTROL RJ-45 connector	3-5, 3-7
Controls and indicators	3-2
Conventions	Notices-ii
Copyright	Notices-i
Customer Service	
Contacting	1-3

D

dB	A-3
dBm	A-3
DC power connector	3-3, 3-6
DCE	A-3
Descriptions	
front panel	2-2
rear panels	2-3
diagnostic error codes	4-2
Documents	
Ordering	1-2
Related	1-2
DS3	A-4
DTE	A-4
DVB	A-4
DVB-S	A-4

E

EBU	A-4
Electronic News Gathering	2-1
Electronic News Gathering (ENG)	B-1
ENG	A-4
Error Codes	
description	4-2
ESD	A-4
ET	A-4

F

FCC	A-4
FEC	A-4
Feedback	1-4
FMR Settings	
Change FMR video deviation frequency	3-40
Change sub-carrier frequencies	3-42
Enable or disable FMR video filtering	3-39

Monitor, enable, or disable Channels	3-43
monitor, enable, or disable De-Emphasis	3-46
Monitor, enable, or disable filtering	3-45
Monitor/change FMR parameters/ settings	3-37

FMT	A-4
Front Panel RS-232 Connector	3-5
front panel settings	3-71

G

GHz	A-4
GI	A-4
Glossary	A-1
GND	A-4
GUI	A-5

H

HD	A-5
How to Use This Manual	1-1
HPU	A-5

I

ID	A-5
IF	A-5
IF IN Connector	3-3, 3-6
IF OUT Connector	3-3, 3-6
ISO	A-5

K

Keypad Switches	3-2
-----------------	-----

L

LAN	A-5
LED	A-5

M

Menu Configurations	
firmware	3-11

Menu Screens	3-8
Menus	
Main Screen	3-8
menu hierarchy	3-9
Overview	3-8
MHz	A-6
MPEG	A-6
MPEG Settings	
Monitor Audio A status	3-21
Monitor Audio B status	3-23
Monitor Chroma status	3-25
Monitor Service Name	3-26
Monitor video status	3-24
MRC	A-6
MRC Customer Service	
Business Hours	1-2
MRC Technical Support	1-3
Business Hours	1-3
E-mail	1-3
Fax	1-3
Telephone	1-3
MRX PLUS Configurations	1-1
MRX4000 PLUS	
Block Diagram	
FMR NTSC/PAL Configuration	2-6
MPEG/COFDM Configuration	2-6
MPEG/COFDM/FMR NTSC/PAL Configuration ..	2-6
Key features	2-2
N	
N/C	A-6
NC	A-6
new US 12 MHz channel plan	B-2
NO	A-6
Notices	Notices-i

NTSC	A-6
Null modem cable	A-6
O	
OB	A-6
ODU	A-6
On-Line Viewing	Notices-ii
Ordering Documentation	1-2
P	
PAL	A-6
PC	A-7
PID	A-7
POWER LED	3-2
Power Options	
AC and DC power sources	2-5
Fuse ratings	2-5
Preparing for Operation	3-7
Proprietary Material	Notices-i
Q	
QAM	A-7
QPSK	A-7
Quality Certification	Notices-i
R	
Rear Panel Power Switch	3-2
Remote Pickup (RPU) operations	B-1
Repairs	
Supported	1-3
RF	A-7
RF IN connector	3-5, 3-7
RF/IF settings	
Change RF/IF section analog/digital operation mode	3-61
Change RF/IF section IF/RF operation mode	3-63
Change RF/IF section squelch level	3-59

Change the MRX4000 PLUS Channel and Channel offset	3-56
Change the MRX4000 PLUS filter setting	3-58
Monitor current Preset RF/IF channel frequency	3-50
Monitor Link Quality	3-52
Monitor or change internal RF/IF section	3-48
Monitor Received Carrier Level	3-51
Monitor the MRX4000 PLUS channel bandwidth	3-55
Select the MRX4000 PLUS frequency band	3-53
RMA	A-7
RS-232 Connector	3-3
S	
SDI OUT Connector	3-5
SERIAL L/Q Connector	3-6
SERIAL L/Q connector	3-3
Society of Broadcast Engineers (SBE) coordinator	B-1
Status LEDs	
Indications	4-1
SUM ALARM Connector	3-5, 3-7
Supported Repairs	1-3
Symbols Used	Notices-ii
System	
Options	
Deployment	2-5
Mounting	2-5
System Menu	
Monitor MRX System active errors	3-67
Monitor/change current active Preset	3-67
Perform system reset	3-70
Review system error log	3-68
Review system information	3-69
System Menu Options	3-65
System Operation	
Presets	2-5

T	
Technical Support	1-3
Contacting	1-3
E-mail address	1-4
Troubleshooting	4-1
Error Codes	4-2
Status LED	4-1
U	
US frequency reallocation plan	B-1
V	
VIDEO MON Connector	3-4, 3-6
VIDEO OUT Connector	3-3, 3-6
Viewing manual on-line	1-1
W	
WARNINGS	Notices-ii
Warranty Information	Notices-iii
All Products	Notices-iv
Product Manufactured by MRC	Notices-iii
Products Manufactured By Others	Notices-iv
Waste Electrical and Electronic Equipment	Notices-ii
WAYSIDE Connector	3-4
WEEE	Notices-ii
What This Manual Covers	1-1