

INSTALLATION, OPERATION & MAINTENANCE MANUAL

**MODEL
E10DM1**

**DESCRIPTION
DP DEMAND TIMER
10-POSITIONS
0-16" H₂O ΔP**

ELECTRONIC DESIGNS, INC.

1683 Rock Hill Highway • Lancaster, SC 29720

Phone: (704) 545-1439 • Fax: (704) 545-8345

Website: www.edi-usa.com

Email: info@edi-usa.com

TABLE OF CONTENTS

<u>Page</u>	<u>Subject</u>
3	General Description
3	Features
4	Mounting & General Wiring
4	Electrical Wiring for Timer used in Hold-Off Mode
4	DP Demand Timer set up for Hold-Off Mode
5	Electrical Wiring for Timer used as Continuous Cycle Timer
5	Additional Electrical Information <ul style="list-style-type: none">• Hold-Off Terminals (TB 2)• 4-20 mA Output Terminals (TB 3)• Remote Control of Set Points
6	Block Diagram for Alternate Method of Remote Control
7	Warranty & Repair
8	General Arrangement Drawing

GENERAL DESCRIPTION – E10DM1

Electronic Designs Incorporated's (EDI) Model E10DM1 is a solid state 10-position timer with built-in Differential Pressure Control, featuring both High and Low Pressure set points. The Differential Pressure (ΔP) is monitored by a solid state sensor and displayed on a large LCD readout. A 4-20 mA output for pressure is included for remote monitoring. The DP Demand Timer is a 4-20 mA closed loop OR open loop system. The ΔP is calibrated for 0-16" H₂O, which corresponds to the output of 4-20 mA. This results in a 1 mA change per 1" H₂O change.

If required by the customer, this timer can also be controllable and programmable from their PLC as follows:

- Bag House Differential Pressure (inches H₂O) can be controlled and programmed
- Hold-Off Feature can be applied remotely.
- The remote Hold-Off can be applied for any length of time. This feature overrides the default setting on the timer "OFF ADJ" potentiometer while applied.
- Any combination of pressures and time of operation can be controlled just by adding a program to the customer PLC.

Timer cycling starts when the High set point is reached and stops when the pressure decreases to the Low set point. Included is a DP Simulator for easy set up of the High and Low set points.

Timer operation can be switched from dual set point control to continuous cleaning.

By relocating the program wire from position #10 (on the Timer) to the number of positions desired, the timer will pulse only from 1 through the programmed number. The timer contains illuminated digital indication (LED) of "next output-to-fire", and indicates timer operation.

FEATURES:

- 120 VAC 50/60 Hz, Single Phase
- 1 amp maximum capacity per output
- 1 amp fuse protection
- All solid state industrial quality construction
- LED indicates "next valve ready to fire"
- Line Surge Protection
- Solid State Differential Pressure Sensor
- LCD Display of Differential Pressure
- DP range 0-16" H₂O
- 4-20 ma output of pressure
- 1" change DP equals 1 ma change in current
- DP Simulator for easy set up of HI, LO Set Points
- Local switch for continuous clean mode
- Timer Hold-Off Circuit (Remote Hold)
- Adjustable ON time: 50 - 150 ms
- Adjustable OFF time: 3 - 100 seconds
- UL Recognized to US and Canadian Standards under File E 60685
- One year Factory warranty against parts or manufacturing defects.

MOUNTING & GENERAL WIRING:

1. Each timer is to be mounted in a dust tight and water tight NEMA rated enclosure.
2. It is recommended that conduit openings/holes be placed in the bottom of enclosure to prevent condensate or moisture from entering the enclosure.
3. Mount the timer enclosure in a vibration-free area. (Use isolators to mount timer to sub plate).
4. Run supply wiring to the timer, 120VAC, 1 Phase, 50/60 Hz from the line circuit protector.
5. Run wiring from the timer to the pilot valve box.

ELECTRICAL WIRING FOR TIMER USED IN HOLD-OFF MODE:

1. Connect 120VAC supply to NEUTRAL (TERMINAL 13) and HI (TERMINAL 14).
2. Connect one side of each valve to the COMMON TERMINAL (TERMINAL 11)
3. Connect the other side of each solenoid valve to the SWITCHED OUTPUTS (TERMINAL 1 through 10), sequentially.
4. SWITCH (SW1) position ↓ for this mode of operation. (DP Position)

DP DEMAND TIMER SET UP FOR HOLD-OFF MODE:

1. With AC power applied to the timer, adjust the Set Point Potentiometers to the desired set points, as follows:
 - a) Turn the High and Low Set Potentiometers to the full **CCW** position.
 - b) Place the Adjust/Operate Switch in the Adjust position
 - c) Turn the Range DP potentiometer to obtain the High Pressure on the LCD.

This is the Differential Pressure which will start the timer.

Example: Start cleaning at 5" H₂O.
 Stop cleaning at 4" H₂O.
 LCD should read 5.0" H₂O.

- d) Turn the High Set Point Potentiometer slowly in the **CW** direction, and stop at a point where the timer lamp goes on. The High or Start Set Point is now set. (5.0" H₂O in our example)
- e) Turn the Low Set Point Potentiometer to the full **CW** position.
- f) Decrease the DP reading to the Low Set Point or Off Set Point (4" H₂O in our example)
- g) Turn the Low Set Potentiometer CCW direction until the timer LED goes out. Timer is now set to start at 5.0" H₂O and stop at 4" H₂O.
- h) The Set Points may be checked by adjusting the DP from MIN to MAX and back to MIN. Reset if necessary.
- i) Place the Adjust/Operate Switch in the Operate position.

ELECTRICAL WIRING FOR TIMER USED AS CONTINUOUS CYCLE TIMER:

1. Connect 120 VAC supply to HI (TERMINAL 14) and NEUTRAL (TERMINAL 13).
2. Connect one side of each valve to the COMMON (TERMINAL 11).
3. Connect the other side of each solenoid valve to the SWITCHED OUTPUTS (TERMINAL 1 through 10), sequentially.
4. SWITCH (SW1) CONTINUOUS position ↑ for this mode of operation. Timer will cycle continuously.

ADDITIONAL ELECTRICAL INFORMATION:

A) HOLD-OFF TERMINALS (TB 2)

Timer cycling can be stopped or placed on hold, by applying a 120 VAC signal to the Hold-Off Terminals (TB 2)

This can be accomplished either in the Hold-Off Mode or the Continuous Mode. Timer cycling will resume with the next output position ready to fire when the 120 VAC signal is removed from TB 2.

B) 4-20 mA OUTPUT TERMINALS (TB 3)

A 4-20 mA signal corresponding to the Differential Pressure is obtainable at TB 3. Proper polarity, plus (+) or minus (-) should be observed. The 4-20 mA signal can be monitored via PLC and this information can be used to program the timer cycling time. The PLC can supply Stop and Start signals to the timer (via TB 2) to maintain a desired Differential Pressure. (see note 4 re: PLC on next page)

C) REMOTE CONTROL OF SET POINTS (Alternate method of operation)

The HI and LO set points can be controlled remotely using a PLC.

EXAMPLE: Desired Start at a Differential Pressure of 7" H₂O, with a Stop cycling point of 5" H₂O.

The 4-20 mA Differential Pressure signal (at TB3) corresponds to a Differential Pressure signal of 0 to 16" H₂O.

Where: 0" H₂O = 4 mA
16" H₂O = 20 mA

$$I = P + 4$$

Where: I is the signal output in mA at TB3.
P is the Differential Pressure in inches H₂O.

For our example: START at 7" H₂O AND STOP at 5" H₂O
 $I = 7 + 4 = 11 \text{ mA}$ $I = 5 + 4 = 9 \text{ mA}$

A PLC can be used to monitor the 4-20 mA output signal from the timer terminal TB3. When the signal reaches 11 mA, the PLC removes the Timer Hold-Off Signal at TB2 and the cycling begins. Timer cycling continuous until the differential decreases to 5" H₂O at which point the current decreases to 9 mA. At this pint (Stop cycle) the PLC applies the Hold-Off signal to TB2 and the timer stops cycling until the DP increases to 7" H₂O (11 mA).

The Timer mode switch SW1 should be set to the "CONT" position (↑) for this type of control. This allows the timer to function without using the on-board set point controls.

It should be noted that several Start and Stop points can be programmed to facilitate different daily load conditions. This allows the user to tailor the cleaning cycle based on work load demand.

1 mA change in current = 1" change in H₂O

BLOCK DIAGRAM FOR ALTERNATE METHOD OF REMOTE CONTROL:

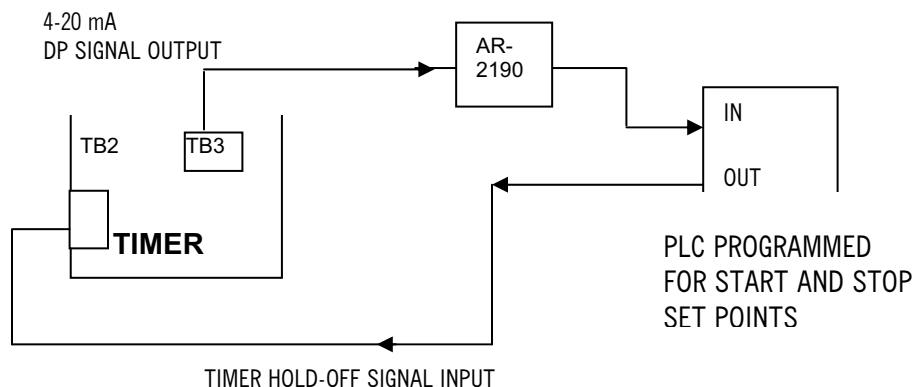

Notes:

1. Timer Switch SW1, should be set to "CONT" (↑) position.
2. The Cleaning Pulse Duration (ON Time) and the time between pulses (OFF Time) are set at the timer.
3. The standard timer requires a 120 VAC Hold-Off signal. Consult factory for other requirements.
4. PLC MONITORING OF 4-20 mA.

It is recommended that a Signal isolator be used if the 4-20 mA output signal is to be monitored by a PLC. EDI's Analog Repeater (AR-2190) provides the proper isolation which prevents ground-loop interference. Please contact factory for details.

WARRANTY & REPAIR:

All EDI products come with a one year warranty against parts and/or manufacturing defects. Please see our terms & conditions or contact us for additional details.

On all products that are over a year old, EDI offers a full test and repair facility at our Lancaster, SC facility. Once we receive a board, it will be logged in, tested, evaluated and then the customer will be advised of the cost to repair or replace. Please contact EDI for additional details on our repair services.

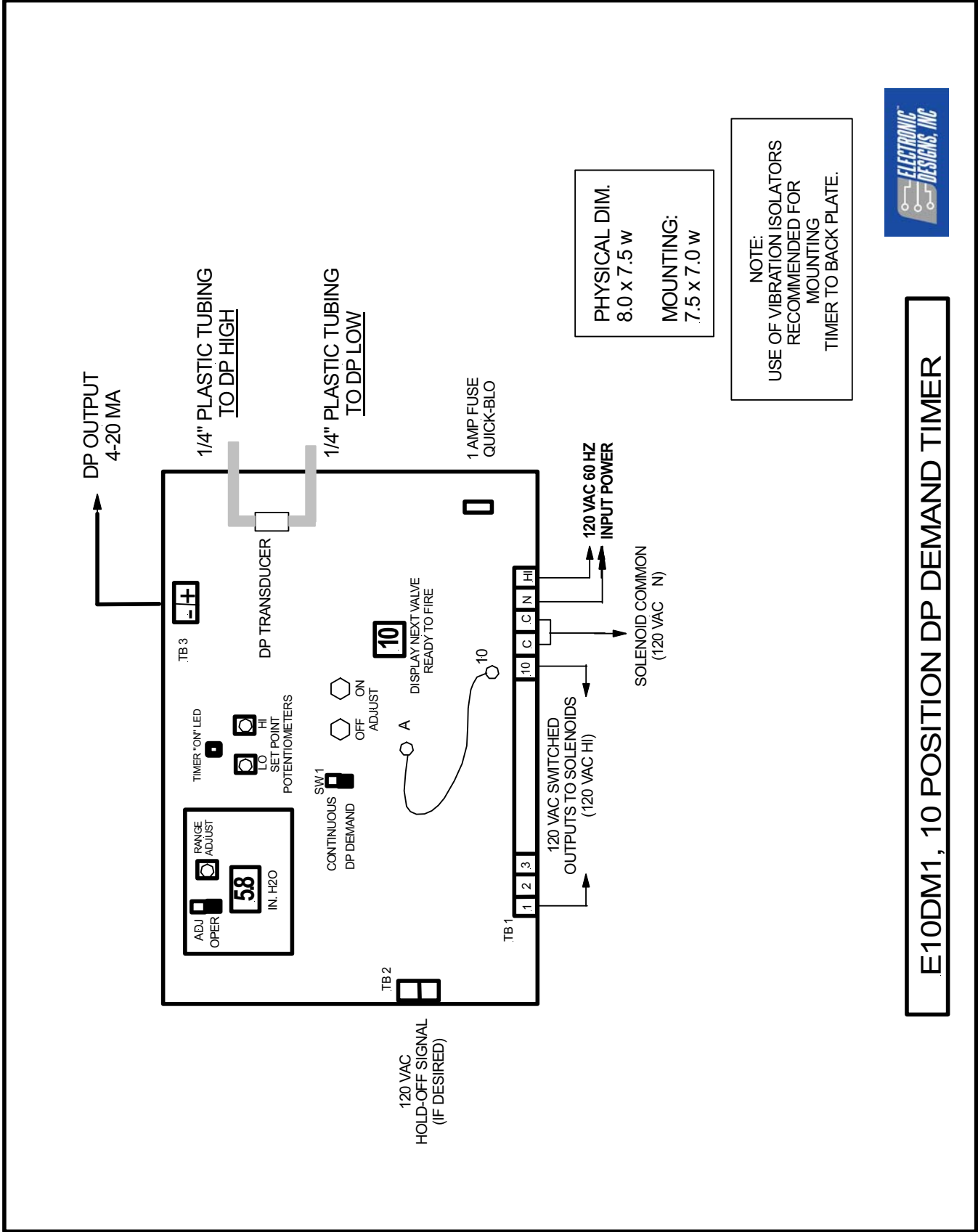

PHYSICAL DIM:
8.0 x 7.5 W
MOUNTING:
7.5 x 7.0 W

NOTE:
USE OF VIBRATION ISOLATORS
RECOMMENDED FOR
MOUNTING
TIMER TO BACK PLATE.



E10DM1, 10 POSITION DP DEMAND TIMER