



Spring/Summer 2017

General Equipment Catalog

***Your Specialists In Liquid Handling Products
Since 1983***

Size Really Does Matter!

If You Want the
Best Service
and Value.

We have over 64,000 square feet of manufacturing & warehouse space with 16 acres of facilities and bulk tank inventory. This allows us to fill your order and ship the same day.



- Custom CAD design for spray equipment and liquid handling systems.
- Specialty welding of stainless steel, aluminum, and polyethylene.
- Complete Service, Repairs, & Maintenance.

- You want it, we've got it! With over 15,000 stock items, your order is ready to ship today.
- Emergency! Same day delivery available.
- 6 Mobile sales people provide you with on-site service for your company's needs.



“Specialists In Liquid Handling Products & Equipment”

**413 ABC Rd. • Lake Wales, Fl. 33853
Sales 800-346-7867 • Fax 863-638-1863**

www.chemicalcontainers.com

TABLE OF CONTENTS

PUMPS	
Flo-Jet.....	1
Shur-Flo.....	1
Hypro.....	2
Udor.....	3
Misc Pumps and Engines.....	3
REGULATORS AND AGITATION NOZZLES	
Regulators.....	4
Agitation Nozzles.....	4
Accumulator.....	4
Pressure Gauge.....	4
SPRAY GUNS	
Spray Guns and Wands.....	5
STRAINERS - HOSE - REELS	
Strainers.....	6
Hose.....	6
Reels.....	6
Quick Couplers.....	6
TANKS -	
Tanks Poly.....	7-9
Tanks Specialty.....	10-12
Tank Bases and Bands.....	13
Tanks - Valves.....	14
FITTINGS	
Stainless Steel.....	15-16
Banjo.....	17-20
CHEMICAL HANDLING EQUIPMENT	
Chem Pumps/Meters.....	21
Chemical Mix/Load Golf.....	22
Fill Systems.....	23
Fill Systems Pre-Mix Transfer.....	24
Environmental Systems.....	25
SPRAYERS	
Skid Mounted Sprayers.....	26-27
Custom Sprayers.....	28
SPECIAL AND CUSTOM EQUIPMENT	
De-Ice Equipment.....	29-30
Rears Sprayers and Eye Systems.....	31-32
Commercial Spray Rigs -Lawn and Tree Care, Herbicide Sprayers and Rail Sprayers.....	33-35
Custom Agriculture Equipment.....	36



Flo-Jet Pumps



Model: 02100-835A
CCI Part # P1509
• Max: 65 PSI • Voltage: 12V DC
• Max: 2.1 GPM • Type: Internal By-Pass
• Ports: 3/8" FPT • Viton/Valve, Santo Diaph.



Model: 02100-122A
CCI Part # P1500
• Max: 60 PSI • Voltage: 12V DC
• Max: 2.2 GPM • Type: Pressure Switch
• Ports: 3/8" FPT • Viton/Valve, Viton Diaph.



Model: 02100-032A
CCI Part # P1501
• Max: 60 PSI • Voltage: 115V AC
• Max: 1.6 GPM • Type: Pressure Switch
• Ports: 3/8" FPT • Santo/Valve, Santo Diaph.



Model: 02100-959A
CCI Part # P1511
• Max: 70 PSI • Voltage: 12V DC
• Max: 1.8 GPM • Type: Internal By-Pass
• Ports: 3/8" FPT • Viton/Valve, Santo Diaph.



Model: 02130-132A
CCI Part # P1498
• Max: 95 PSI • Voltage: 12V DC
• Max: 1.8 GPM • Type: Pressure Switch
• Ports: 1/4" FPT • Viton/Valve, EPDM Diaph.



Model: 04300-500A
CCI Part # P1499
• Max: 45 PSI • Voltage: 12V DC
• Max: 3.7 GPM • Type: Pressure Switch
• Ports: 1/2" Barb • Viton/Valve, Santo Diaph.



Model: R7000
CCI Part # P1400
• Max: 80 PSI • Voltage: 12V DC
• Max: 7.0 GPM • Type: Pressure Switch
• Ports: 3/4" HB • EPDM or Viton/Valve, Santo Diaph.



Model: 04300-504
CCI Part # P1502
• Max: 45 PSI • Voltage: 12V DC
• Max: 4.9 GPM • Type: Pressure Switch
• Ports: 3/4" HB • Viton/Valve, Santo Diaph.

Shur-Flo Pumps



Model: 8000-543-236
CCI Part # P1600
• Max: 60 PSI • Voltage: 12V DC
• Max: 1.4 GPM • Type: Pressure Switch
• Ports: 3/8" FPT • Viton/Valve, Santo Diaph.



Model: 8000-533-236
CCI Part # P1600A
• Max: 60 PSI • Voltage: 115V AC
• Max: 1.4 GPM • Type: Internal By-Pass
• Ports: 3/8" FPT • Viton/Valve, Santo Diaph.



Model: 8007-543-836
CCI Part # P1625A
• Max: 60 PSI • Voltage: 12V DC
• Max: 1.4 GPM • Type: Toggle Switch & PS
• Ports: 3/8" FPT • Viton/Valve, Santo Diaph.



Model: 8030-813-239
CCI Part # P1625
• Max: 150 PSI • Voltage: 12V DC
• Max: 1.5 GPM • Type: Pressure Switch
• Ports: 3/8" FPT • Viton/Valve, Santo Diaph.



Model: 2088-343-135
CCI Part # P1601
• Max: 45 PSI • Voltage: 12V DC
• Max: 3.0 GPM • Type: Pressure Switch
• Ports: 1/2" MPT • Viton/Valve, Santo Diaph.



Model: 2088-414-534
CCI Part # P1601B Epoxy Coated
• Max: 45 PSI • Voltage: 12V DC
• Max: 3.0 GPM • Type: Pressure Switch
• Ports: 1/2" MPT • Viton/Valve, Santo Diaph.



Model: 8000-541-236
CCI Part # P1599
• Max: 60 PSI • Voltage: 12V DC
• Max: 1.0 GPM • Type: Pressure Switch
• Ports: 3/8" FPT • Viton/Valve, Santo Diaph.



Model: 8000-543-238
CCI Part # P1627
• Max: 100 PSI • Voltage: 12V DC
• Max: 1.47 GPM • Type: Pressure Switch
• Ports: 3/8" FPT • Viton/Valve, Santo Diaph.

Hypro Centrifugal Pumps



Model: H9202C
Type: Cast Iron
Specifications:
 • Max Flow: 136 GPM
 • Max: 180 PSI
 • Max: 6000 RPM
 • Shaft: 5/8"



Model: H9203PS
Type: Poly Pump
Specifications:
 • Max Flow: 92 GPM
 • Max: 80 PSI
 • Max: 4200 RPM
 • Shaft: 7/8" Stainless



Model: H9203C-SP
Type: Cast Iron
Self-Priming
Specifications:
 • Max Flow: 120 GPM
 • Max: 157 PSI
 • Max: 5500 RPM
 • Shaft: 5/8"



Model: H9700B
Type: Bronze
12 Volt
Specifications:
 • Max Flow: 19 GPM
 • Max: 7 PSI
 • Max: 5.5 AMPS
 • Ports: 3/4" FPT



Model: H9006C-O
Type: Cast Iron
Specifications:
 • Max Flow: 117GPM
 • Max: 78 PSI
 • Max: 600 RPM
 • Shaft: 1 3/8"



Model: H9303C
Type: Cast & SS
HM1C- 5C Hydraulic Driven
Specifications:
 • Max Flow: 114 GPM
 • Max: 130 PSI

Hypro Roller Pumps



Model: H4101C
Type: Cast Iron
Specifications:
 • Max Flow: 7GPM
 • Max: 150 PSI
 • Max: 2600 RPM
 • Ports: 3/4" FPT
 • Shaft Size: 5/8"



Model: H6500C
Type: Cast Iron
Specifications:
 • Max Flow: 9.7 GPM
 • Max: 300 PSI
 • Max: 1200 RPM
 • Ports: 3/4" FPT
 • Shaft Size: 5/8"



Model: H7560C
Type: Cast Iron
Specifications:
 • Max Flow: 22.5 GPM
 • Max: 300 PSI
 • Max: 1000 RPM
 • Ports: 3/4" FPT
 • Shaft Size: 15/16"



Model: H7700C
Type: Cast Iron
Specifications:
 • Max Flow: 22.1GPM
 • Max: 300 PSI
 • Max: 1000 RPM
 • Ports: 3/4" FPT
 • Shaft Size: 15/16"

Hypro Piston Pumps



Model: H5330C-CHX
Type: Cast Iron
Specifications:
 • Max Flow: 3 GPM
 • Max: 500 PSI
 • Max: 1800 RPM
 • Shaft: 5/8"



Model: H5210C
Type: Cast Iron
Specifications:
 • Max Flow: 10 GPM
 • Max: 400 PSI
 • Max: 600 RPM
 • Shaft: 1", or 1-3/8" H

Hypro Diaphragm Pumps



Model: H9910-D252
Specifications:
 • Max Flow: 6 GPM
 • Max: 290 PSI
 • Max: 3600 RPM
 • 3/4" Inlet, 1/2" Outlet



Model: H9910-D30
Specifications:
 • Max Flow: 9.5 GPM
 • Max: 580 PSI
 • Max: 3600 RPM
 • 1" Inlet, 1/2" Outlet



Model: H9910-D50
Specifications:
 • Max Flow: 14 GPM
 • Max: 580 PSI
 • Max: 550 RPM
 • 1-1/4" Inlet, 1/2" Out



Model: H9910-D423
Specifications:
 • Max Flow: 11 GPM
 • Max: 290 PSI
 • Max: 650 RPM



Udor Diaphragm Pumps



Model:
UKAPPA1812Volt

Specifications:
 • Max Flow: 4 GPM
 • Max: 70 PSI
 • Voltage: 12V DC
 • 3/4" Inlet, 1/2" Outlet



Model:
UIOTA20

Specifications:
 • Max Flow: 4.5 GPM
 • Max: 275 PSI
 • Max: 540 RPM
 • 3/4" Inlet, 3/8" Outlet



Model:
UIOTA17M Electric

Specifications:
 • Max Flow: 4.5 GPM
 • Max: 200 PSI
 • Voltage: 115V AC
 • 3/4" Inlet, 3/8" Outlet



Model:
UKAPPA40
UKAPPA40GR

Specifications:
 • Max Flow: 10.5 GPM
 • Max: 560 PSI
 • Max: 540 RPM
 • 1" Inlet, 1/2" Outlets



Model:
UKAPPA55
UKAPPA55GR5
UKAPPA55GR8

Specifications:
 • Max Flow: 15 GPM
 • Max: 350/560 PSI
 • Max: 540 RPM
 • 1-1/4" Inlet, 1/2" Outlets



Model:
UKAPPA75
UKAPPA75GR

Specifications:
 • Max Flow: 20 GPM
 • Max: 560 PSI
 • Max: 540 RPM
 • 1.25" Inlet, 3/4" Outlet



Model:
UKAPPA100
UKAPPA100C
UKAPPA100GR

Specifications:
 • Max Flow: 26GPM
 • Max: 560 PSI
 • Max: 540 RPM
 • 1-1/2" Inlet, 1/2" Outlets



Model:
UKAPPA120/TS
UKAPPA120/CC
UKAPPA120/GR

Specifications:
 • Max Flow: 35 GPM
 • Max: 700 PSI
 • Max: 540 RPM
 • 1.50" Inlet, 3/4" Outlet



Model:
URO110
URO110C
URO110GR-5
URO110GR

Specifications:
 • Max Flow: 29GPM
 • Max: 300 PSI
 • Max: 540 RPM
 • 1-1/4" Inlet, 3/4" Outlets



Model:
UBETA150CC

Specifications:
 • Max Flow: 42 GPM
 • Max: 700 PSI
 • Max: 540 RPM
 • 1.50" Inlet, 3/4" Outlet

Additional Pumps/Engines/Gear Box

Banjo Transfer Pumps



Model:
B205PB-V
B200PB-I
B200PB-SS

Description:
 • 2" Poly Pump
 • 2" Cast Iron Pedestal Pump
 • 2" SS Pedestal Pump



Banjo 2" Pumps w/Gas Engine

Model:
B200PH-5
B200PH-5E

Description:
 • 2" Poly Pump
 • Electric Start option

ACE Poly Pumps w/ Gas Engine



Model:
GE-85-LE
GESC-85-LE

Description:
 • 1" Poly Pump
 • 1" Silicon Carbide Seal
 • 2" SS Pedestal Pump



Honda Engines

Model: Description:
 E110 GX160 Standard w/Oil Alert
 E115 GX160 6:1 Gear Reduction
 E120 GX240 Standard w/Oil Alert
 E141A GX390 Standard w/Oil Alert



Model:
H9910KIT1640
D30 Gear Box
H9910KIT1642
D50 Gear Box

Specifications:
 • 6:1 Gear Reduction
 • Fits: 3/4" Shaft Engine
 • 6:1 Gear Reduction
 • Fits: 1" Shaft Engine



Honda Engines w/Electric Start

Model: Description:
 E116 GX160 Standard w/Oil Alert
 E125 GX240 Standard w/Oil Alert
 E141 GX390 Standard w/Oil Alert



Model:
H9910KIT1990

Specifications:

- Fits: D252 Diaph. Pump
- Max: 275 PSI
- Max: 6 GPM
- 5/8" Bypass, 3/8" Outlet



Model:
H9910-GS40GI

Specifications:

- Fits: D30/D50 Pumps
- Max: 550 PSI
- Max: 15 GPM
- 5/8" Bypass, 1/2" Outlet



Model:
U6010.23

Specifications:

- Fits: IOTA17 Pump
- Max: 275 PSI
- Max: 5 GPM
- 3/8" Bypass Port



Model:
U6010.24

Specifications:

- Fits: Kappa40,55 Pumps
- Max: 560 PSI
- Max: 20 GPM
- 3/4" Bypass, 1/2" Outlet



Model:
U6047.06

Specifications:

- Fits: Kappa75 Pump
- Max: 560 PSI
- Max: 26 GPM
- 3/4" Bypass, 1/2" Outlet



Model:
U6005.31

Specifications:

- Fits: Gamma62 Pump
- Max: 600 PSI
- Max: 26 GPM
- 3/4" BSP Inlet, 3/4" Bypass



Model:
UD1/4.50
UD1/4.150

Specifications:

- Fits: Kappa18/12V
- Max: 50/150 PSI
- Max: 4.5 GPM
- 1/4" Inlet, 1/4" Bypass



Model:
U6005.15

Specifications:

- Fits: Universal Application
- Max: 1000 PSI
- Max: 45 GPM
- 3/4" Inlet, 1" Bypass



Model:
S8460-3/4

Specifications:

- Max: 70 GPM
- Max: 300 PSI
- 3/4" Inlet, 3/4" Out
- 1/4" Gauge Port



Model:
S6815-3/4-300
S6815-3/4-700

Specifications:

- Max: 65 GPM
- Max: 300/700 PSI
- 3/4" Inlet, 3/4" Outlet
- Brass Body



Model:
S23120A-1/2-PP
S23120A-3/4-PP

Specifications:

- Fits: Universal Application
- Max: 150 PSI
- Max: 30 GPM
- 1/4" Gauge Port



Model:
S12690-3/4-NYB

Specifications:

- Throttling Valve
- Max: 125 PSI
- Max: 56 / 82 GPM
- 1/2", 3/4" Connections

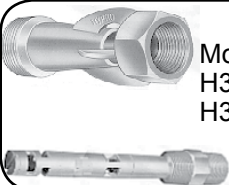

Hypro Jet Agitators

Model:
H3371
H3371-0019

Specifications:

- 1/2" FPT Inlet Jet Orifice
- 3/4" MPT Inlet Orifice
- Nylon Body and Orifice
- Jet Agitator



Hypro HV Jet Agitator

Model:
H3371-0028

Specifications:

- 3/4" MPT Inlet Jet Orifice
- High Volume Jet Agitator
- 3 Orifices to match flow
- Glass-filled Polypropylene



Hypro Accumulator Tank

Model:
H3375-0003

Specifications:

- Surge Tank – Dampener
- Max: 500 PSI
- Max: 10 GPM
- 1/2" MPT Connection



Pressure Gauges

Model:
M201 0-100 PSI
M202 0-200 PSI
M203 0-300 PSI
M204 0-600 PSI

Specifications:

- 2-1/2" Liquid Filled Gauge
- Stainless Case
- Brass Internal Parts & Stem
- 1/4" NPT Stem



Spray Guns

Model:
S22670PP15406

- Specifications:
- Max: 150 PSI
 - Adjustable Spray Tip
 - Lightweight Polypro
 - 15" Extension, 3/8 Inlet

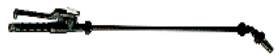

Model:
U4.802.14WB

- Specifications:
- Max: 300 PSI
 - 20" Stainless Wand
 - Adjustable Spray Tip
 - Poly Trigger Valve



Model:
SAA31

- Specifications:
- Max: 500 PSI
 - Max: 3 GPM
 - Forged Brass Body
 - 1/4" MPT Inlet



Model:
S4688

- Specifications:
- Max: 250 PSI
 - Max: 2 GPM
 - Forged Brass Body
 - 1/4" FPT Inlet, 11/16 Outlet



Model:
S4754

- Specifications:
- Brass Handle Extension
 - 1/4" MPT x 3/4" FGHT
 - Strainer Handle 50 M
 - 1/4" FPT Inlet



Model: Straight Ext.	Model: Curved Ext.
S7715-8	S6671-8
S7715-18	S6671-18
S7715-24	S6671-24
S7715-36	S6671-36



Model:
AA30L-22425-18
AA30L-22425-24
AA30L-22425-36
AA30L-22425-48

- Specifications:
- Max: 250 PSI
 - Max: 5 GPM
 - Brass Wand, Nylon Grip
 - 1/4" FPT Inlet



Model:
SAA43H-6

- Specifications:
- Max: 800 PSI
 - Max: 14 GPM
 - Brass / Aluminum Const.
 - 1/2" Inlet



Model:
S25660-0

- Specifications:
- Max: 200 PSI
 - Max: 6 GPM
 - Nylon w/Viton O-Rings
 - 3/4" FPT Inlet



Model:
SAA2-60

- Specifications:
- Max: 800 PSI
 - Max: 10 GPM
 - Brass Body
 - 3/4" FHT Inlet



Model:
U26.901.162

- Specifications:
- Max: 850 PSI
 - Max: 15 GPM
 - Adjustable Spray Pattern
 - 1/2" HB Inlet



Model:
U35.901.16

- Specifications:
- Max: 600 PSI
 - Max: 5 GPM
 - 7" Barrel Extension
 - 1/2" HB Inlet



Model:
U23.208.84

- Specifications:
- Max: 700 PSI
 - Max: 18 GPM
 - Nickel Plated Aluminum
 - 1/2" FPT Inlet



Model:
U7.901.103

- Specifications:
- Max: 850 PSI
 - Max: 25 GPM
 - 17" Barrel, Adj. Pattern
 - 1/2" HB Inlet



Model:
GGJD9C-B

- Specifications:
- Max: 550 PSI
 - Max: 10 GPM
 - Quick Adj. Spray Pattern
 - 3/4" FPT Inlet



- Model:
CCILAWNGUN
- Specifications:
- 36" Aluminum Spray Wand
 - 1/2" Quick Coupler
 - 1/2" Brass Ball Valve
 - Flat Fan Lawn Spray Tip



Filter / Strainers



Hypro Strainers

Model:	Size:	Model:	Size:
H3350-0082	1/4"	H3350-0075	1-1/4"
H3350-0042	1/2"	H3350-0113	1-1/2"
H3350-0044	3/4"	H3350-0061	1"



Polypropylene Clear Bowl Strainers

Model:	Size:
HLSFP012VS2CC	1/2" FPT Strainer
HLSFP034VS2CC	3/4" FPT Strainer
HLSFP100VS2CC	1" FPT Strainer
HLGFP112VS4C	1-1/2" FPT Strainer



Spraying Systems Strainers

Model:	Size:
SAA124A34PP50	3/4" FPT
SAA124A1PP50	1" FPT
SAA12411/4NY50	1-1/4" FPT
SAA12411/2NYB50	1-1/2" FPT



Banjo Y-Strainers

Model:	Size:
BLS10040	1" Strainer / 40 Mesh
BLS15050	1-1/2" Strainer / 50 Mesh
BLS20050	2" Strainer / 50 Mesh
BLS30020	3" Strainer / 20 Mesh

Spray Hose

PVC Clear Braided Hose

Model:	Size:	Model:	Size:
HZ929	1/4" ID	HZ933	3/4"
HZ930	3/8" ID	HZ934	1"
HZ931	1/2" ID	HZ934A	1-1/4"
HZ932	5/8" ID		



High Pressure PVC Spray Hose (600 PSI)

Model:	Size:	
HZ900	3/8" ID	• 300' Per Roll
HZ901	1/2" ID	
HZ903	3/4" ID	

Red Rubber Spray Hose (200 PSI)

Model:	Size:
HZ904	3/8" ID
HZ905	1/2" ID
HZ905A	3/4" ID
HZ906	1" ID



PVC Suction Hose

Model:	Size:	Model:	Size:
HZ910	3/4" ID	HZ914	2" ID
HZ911	1" ID	HZ915	3" ID
HZ912	1-1/4" ID	HZ916	4" ID
HZ913	1-1/2" ID		

Hose Reels



Hannay Hose Reels

Model:	Description:
HZ968	10" (1/2" Hose x 100' Capacity)
HZ974	12" (1/2" Hose x 150' Capacity)
HZ975	18" (1/2" Hose x 300' Capacity)
HZ976	18" (1/2" Hose x 300' Capacity) Elect.



Titan Hose Reels

Model:	Description:
HZ4312	12" Aluminum/SS Hose Reel
HZ4318	18" Aluminum/SS Hose Reel
HZ5512	12" All Stainless Steel Reel
HZ5518	18" All Stainless Steel Reel



Hose Reel Swivels

Model:	Description:
HZ973	1/2" 90° Brass Swivel
HZ8620	1/2" 90° Stainless Swivel



Reusable Hose Repair End

Model:	Description:
FB600	3/8" MPT x 3/8" Hose
FB601	3/8" MPT x 1/2" Hose
FB603	1/2" MPT x 3/8" Hose
FB604	1/2" MPT x 1/2" Hose

Quick Couplers



Male Quick Coupler Plugs

Model:	Description:
FB430A	1/4" MPT Brass Plug
FB429	3/8" MPT Brass plug
FB433	1/2" MPT Brass Plug



Female Quick Coupler Plugs

Model:	Description:
FB430	1/4" FPT Brass Plug
FB428	3/8" FPT Brass Plug
FB432	1/2" FPT Brass Plug
FB434	3/4" FPT Brass Plug



Male Quick Coupler Socket

Model:	Description:
FB419	3/8" MPT Socket Brass
FB423	1/2" MPT Socket Brass



Female Quick Coupler Socket

Model:	Description:
FB431	1/4" FPT Socket Brass
FB418	3/8" FPT Socket Brass
FB422	1/2" FPT Socket Brass
FB425	3/4" FPT Socket Brass



Polyethylene Storage Tanks

Vertical Storage Tank

- 100% Virgin Polyethylene
- FDA approved for potable water storage
- Molded in gallon indicators on sides



Available in sizes up to 12,000 Gallons.

Model:	Gal.	Dia.	Height	Lid
T1007A	20	16"	48"	8"
T1008N	25	18"	29"	5"
T1009A	40	18"	43"	5"
T1010N	50	18"	53"	5"
T1012N	65	23"	43"	8"
T1014A	75	23"	50"	8"
T1016D	100	30"	36"	8"
T1018N	100	28"	43"	8"
T1020N	105	23"	63"	8"
T1024N	120	38"	29"	5"
T1026N	150	30"	56"	8"
T1028N	165	31"	56"	16"
T1030N	200	30"	72"	16"
T1032N	210	32"	69"	16"
T1040N	220	42"	41"	5"
T1046N	250	30"	89"	8"
T1047N	265	31"	88"	8"
T1056R	330	47"	51"	16"
T1048N	300	36"	79"	16"
T1052N	305	46"	50"	16"
T1056R	330	47"	48"	16"
T1058A	425	42"	75"	8"
T1060N	500	48"	73"	16"
T1060AA	505	46"	80"	16"
T1068N	550	67"	44"	16"
T1070A	625	64"	50"	8"
T1071D	650	56"	68"	16"
T1072N	750	48"	103"	16"
T1076N	850	48"	118"	16"
T1076A	850	54"	92"	8"
T1086A	900	46"	132"	16"
T1088N	1000	64"	80"	16"
T1096N	1100	87"	53"	16"
T1100R	1200	86"	53"	16"
T1100A	1200	64"	94"	16"
T1104N	1500	64"	116"	16"
T1108N	1550	87"	67"	16"
T1112R	1700	86"	72"	16"
T1116A	2000	90"	84"	16"
T1116AA	2000	64"	165"	16"
T1120O	2025	64"	153"	16"
T1124N	2100	87"	89"	16"
T1125A	2150	102"	71"	16"
T1128N	2500	95"	91"	16"

Vertical Storage Tanks Cont:

Model:	Gal.	Dia.	Height	Lid
T1128A	2500	90"	100"	16"
T1132N	3000	95"	109"	16"
T1136N	4000	102"	125"	16"
T1136A	4000	96"	140"	16"
T1138N	4200	102"	131"	16"
T1140N	5000	102"	152"	16"
T1148N	6000	102"	182"	16"
T1152N	6100	120"	139"	16"
T1156N	6500	120"	150"	16"
T1156O	6500	102"	196"	16"
T1158N	7800	119"	176"	16"
T1159N	8400	119"	188"	16"
T1160N	9000	141"	144"	16"
T1164N	10000	141"	159"	16"
T1165N	10500	144"	165"	22"
T1168N	12500	144"	194"	22"
T1170N	15000	144"	244"	16"
T1170NW	15000	165"	186"	16"
T1175N	20000	165"	242"	16"

Poly Cone Bottom Tanks



- 100% Virgin Polyethylene
 - FDA approved for potable water storage
 - Molded in gallon indicators on sides
- Available in sizes up to 7500 Gallons.
*Includes poly stand

Model:	Gal.	Dia.	Height	Lid
T5042A	10	13"	21"	8"
T2004N	15	19"	25"	8"
T2007A	30	24"	26"	12"
T2008N	35	23"	27"	8"
T2009A	40	30"	34"	12"
T2015A	60	24"	39"	12"
T2015N	60	31"	31"	16"
T2020O	80	32"	34"	10"
T2121A	85	30"	44"	12"
T2025A	110	30"	51"	12"
T2026R	110	44"	34"	6"
T2030A	150	36"	51"	12"
T2032N	175	42"	49"	8"
T2037A	200	42"	54"	12"
T2038R	220	44"	50"	6"
T2040D	250	47"	51"	16"
T2044N	300	49"	52"	16"
T2044A	300	49"	61"	16"
T2045N	310	43"	72"	8"
T2048D	400	47"	69"	16"
T2052N	500	48"	85"	16"
T2058D	600	47"	91"	16"
T2062N	750	72"	55"	16"
T2067A	1000	64"	98"	16"
T2068N	1050	72"	85"	16"

Poly Cone Bottom Tanks Cont:

Model:	Gal.	Dia.	Height	Lid
T2070A	1490	64"	132"	16"
T2074N	1600	88"	94"	16"
T2080N	2500	95"	105"	16"
T2082N	2500	95"	114"	16"
T2086N	3000	95"	121"	16"
T2086A	3000	95"	131"	16"
T2089A	4900	102"	159"	16"
T2090N	5500	119"	146"	16"
T2092N	6000	102"	195"	16"
T2094N	7500	141"	148"	16"

See Page 13 for Stands

Horizontal Applicator Tanks



Model:	Gal.	Dia.	Length	Lid
T4012N	12	14"	18"	5"
T4016N	14	13.5"	31"	5"
T4020N	20	15"	28"	5"
T4028N	30	23"	22"	5"
T4032N	55	23"	34"	8"
T4036N	85	23"	52"	5"
T4040A	95	24"	56"	5"
T4044N	110	30"	42"	8"
T4048N	150	32"	46"	8"
T4056N	200	32"	62"	8"
T4060N	200	38"	47"	8"
T4072N	300	38"	68"	8"
T4076N	400	42"	73"	8"
T4080N	500	48"	75"	8"

Ask about Saddles and Cradles

Slimline Space Saver Tanks



Model:	Gal.	Wid.	Length.
T4052N	150	28"	40" / 50"
T4064A	200	24"	46" / 61"
T4068A	250	24"	51" / 61"

Elliptical Leg Tanks



This elliptical leg tank style is designed to provide the greatest capacity with the lowest center of gravity, making it the best design for transporting larger volumes. Elliptical tanks feature mold-in legs that act as "baffles" to reduce sloshing and provide increased stability during transport.

Model:	Gal.	W.	L.	H.	Lid	Band
T3130N	335	48"	71"	33"	16"	2
T3140A	510	57"	80"	39"	16"	2
T3140N	535	57"	80"	39"	16"	2
T3144N	1035	79"	89"	53"	16"	3
T3152N	1635	71"	142"	57"	16"	4
T3156N	2035	84"	142"	55"	16"	4
T3160N	2635	90"	140"	71"	16"	4
T3164N	3135	88"	151"	76"	16"	4
T3168N	4035	92"	192"	77"	16"	4

See Page 13 for Bands

Elliptical Tanks



Model:	Gal.	W.	L.	H.	Lid
T8008N	200	40"	66"	30"	8"
T8012N	300	48"	70"	32"	8"
T8016N	500	57"	82"	38"	16"
T8020N	750	69"	88"	44"	16"
T8024N	1000	78"	90"	51"	16"
T8025N	1600	78"	138"	49"	16"
T8026N	2550	88"	142"	69"	16"

Spot Sprayer Tanks

- Molded inserts for pump mounting & accessories.
- Molded in gallon indicators on side walls for easy calibration.

Model:	Gallons
T4016R	14
T4017A	15
T4024A	25
T4024R	25
T4029A	40
T4035A	60





Horizontal Leg Tanks

Used primarily for transport and nursing applications, leg tanks feature molded-in legs that act as "baffles" to reduce sloshing.

See Page 13 for Bands

Model:	Gal.	Dia.	Length	Lid	Band
T3004N	35	20"	29"	5"	2
T3004A	35	18"	34"	5"	2
T3008N	65	23"	43"	5"	2
T3008A	65	24"	39"	5"	2
T3012N	125	32"	41"	8"	2
T3012A	125	32"	40"	8"	3
T3002A	165	32"	54"	8"	3
T3016N	225	38"	49"	8"	2
T3016A	225	38"	52"	8"	3
T3020N	325	38"	68"	16"	2
T3022A	335	44"	56"	16"	3
T3021N	425	49"	60"	16"	2
T3024N	525	49"	71"	16"	2
T3025A	535	48"	78"	16"	3
T3028N	725	49"	101"	16"	3
T3029A	735	48"	103"	16"	3
T3032N	1025	49"	139"	16"	4
T3033A	1065	58"	106"	16"	3
T3033N	1325	66"	99"	16"	4
T3036N	1625	63"	134"	16"	4
T3037N	5025	92"	190"	16"	5

Poly Loaf Tanks

- Loaf tanks are molded non-corrosive polyethylene with one piece seamless construction
- FDA approved for potable water storage
- * Tanks do not include lids or fittings.

Model:	Gal.	Len.	Wid.	Height
T5034R	6	16	12	8
T5052R	12	23	14	10
T5058R	13	20	17	9
T5066R	14	20	18	9
T5088R	15	23	14	12
T5094R	15	27	14	10
T5102R	20	22	19	11
T5116R	20	26	14	13
T5124R	21	34	12	12
T5132R	21	36	20	7
T5152R	28	50	16	8
T5154R	29	30	20	12
T5166R	31	30	24	10
T5174R	35	48	17	10
T5192R	50	36	18	18
T5198R	61	35	27	15
T5206R	65	73	32	6

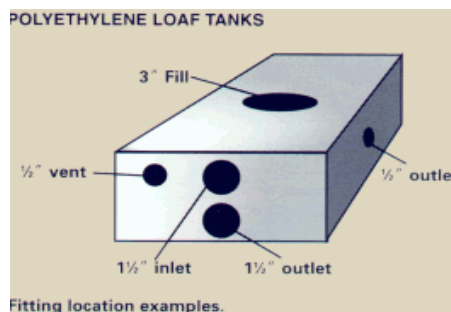

Pest Control Tanks



These tanks are rotationally molded polyethylene with a ribbed design for extra strength. The standard color is white-UV inhibitors are added for protection against sunlight (optional colors available in large quantities). They are ideal for agricultural, nursery, lawn care and commercial turf sprayers.

Model:	Gal.	Len.	Wid.	Height
T5520N	30	25"	19"	20"
T5530A	50	38"	19"	20"
T5540A	100	38"	30"	26"
T5550A	150	48"	37"	26"
T5560A	200	48"	36"	35"
T5570A	300	69"	36"	35"

Part # T9670CCS



275 Gallon UN Transparent Tanks (Reconditioned)
6" Top Lid
2" Bottom Valve
Polyethylene Bottle
Galvanized Steel Cage
40"W x 48"D x 45"H
Call for Pricing

Heavy walled tanks designed to withstand rugged service. Open top for convenient mixing and filling, self supporting, translucent-visible content level, FDA approved material. Optional steel stands with corrosion resistant coating, or stainless steel, constructed stands are available.

Double Wall Storage Tanks

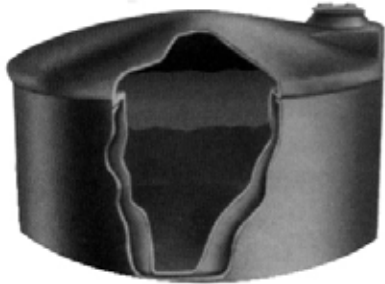

Model:	Gal.	Dia.	Height	Lid
T7004RDBL	18	21"	21"	8"
T7008RDBL	35	21"	34"	8"
T7012RDBL	65	26"	35"	8"
T7016PDBL	105	36"	42"	5"
T7020RDBL	120	32"	44"	8"
T7024PDBL	160	36"	59"	5"
T7030PDBL	540	77"	48"	10"
T7034PDBL	1000	77"	79"	19"
T7040PDBL	1550	96"	84"	19"
T7046PDBL	2500	96"	119"	16"
T7050PDBL	3150	122"	92"	24"
T7060PDBL	4400	122"	118"	24"
T7066PDBL	5400	143"	117"	24"
T7080PDBL	8700	143"	174"	24"

Transport Tanks

This one-piece, molded polyethylene tank is designed for economy. The low profile, flat bottom rectangular design saves space and does not need stands or cradles for support. The tank comes complete with an 8" anti-surge vented fill cap and molded-in calibrations.

Model:	Gal.	Len.	Wid.	Ht.	Lid
T5191A	45	37"	18"	18"	5"
T9620R	50	38"	26"	13"	8"
T5192A	50	38"	19"	20"	8"
T5245A	100	43"	27"	26"	8"
T9640R	110	38"	16"	26"	8"
T9640A	110	48"	35"	17"	5"
T5252A	150	48"	36"	25"	8"
T9680R	300	62"	42"	29"	8"

The fluid containment basin is designed around the need for environmental protection and to meet federal and state requirements for the storage of chemicals.

Polyethylene Containment Basins



Model:	Gal.	Len.	Wid.	Dia.	Ht.
T6082D	90			44"	
T6084A	110	55"	31"		25"
T6088D	110	72"	36"		12"
T6090A	150	75"	31"		25"
T6092D	175	48"	48"		18"
T6096D	240	48"	65"		18"
T6103AG	320			72"	24"
T6104D	350	68"	68"		18"
T6108D	400			78"	23"
T6112D	450			70"	30"
T6091A	610	96"	24"		
T6116C	675			66"	46"
T6117C	675			82"	30"
T6124D	690	106"	58"		26"
T6125P	700			96"	72"
T6128A	1150	73"	73"		66"
T6128CB	950			86"	38"
T6132C	1000			84"	46"
T6139A	1200			86"	56"
T6140A	1650	84"	84"		60"
T6164NG	2000			139"	36"
T6168CB	2075	96"	96"		62"
T6169A	2200			90"	83"
T6170N	2800			102"	104"
T6172P	3350			144"	50"
T6176T	3500	218"	108"		40"
T6161A	2075	96"	96"		62"

Cone Bottom Mini-Bulk Tanks

These polyethylene tanks come with bases that allow stacking up to three high fully loaded. Forklift pockets are built in for easy loading/unloading. Both size tanks have 6" fill lids and bottom discharge.



Model:	Gal.	Dia.	Ht.
T2026R	110	44"	34"
T2038R	220	44"	50"



Specialty Tanks



Model:	Type	Gal.	Len.	Wid.	Ht.	Lid
T9680A	Dock Float		48"	24"	12"	
T9687N	Free Stand	300	48"	29"	62"	16"
T9689A	Free Stand	250	62"	29"	42"	16"
T9690A	Free Stand	400	62"	29"	66"	16"
T9890N	Low Profile	1250	130"	81"	38"	16"
T9891N	Low Profile	1500	130"	81"	44"	16"
T9700N	Horiz. Box	2400	150"	90"	53"	16"
T5174A	Total Drain	35	28"	19"	20"	5"
T5198A	Total Drain	56	38"	20"	26"	5"

Total Drain Tanks



Model:	Gal.	Len.	Wid.	Ht.	Lid
T5025ATD	2.5	7"	15"	14"	5"
T5027A	4	11"	11"	15"	5"
T5028A	5	11"	11"	20"	5"
T5042A	10	13"	13"	21"	5"
T5174A	35	28"	19"	20"	5"
T5198A	56	38"	20"	26"	5"

Telone



Below Ground Cistern Tanks

Our below ground cisterns feature the same rugged, ribbed design found in our septic tanks. Cisterns are ideal for instances when drinking water must be hauled in, or when a well just doesn't meet consumption needs. Bulkhead fittings are available in full range of sizes to help adapt the cistern to suit specific needs or applications.

Model:	Gal.	Len.	Wid.	Ht.	Lid
T6046N	325	Sphere	54"	51"	20"
T6048N	600	101"	51"	42"	20"
T6052N	1200	102"	60"	58"	20"
T6058N	1700	135"	55"	66"	20"
T6059N	2500	158"	98"	53"	20"

Septic Tanks

For septic system replacements and new home construction, polyethylene septic tanks are designed for both durability and quick easy installation. Any septic tank can be transported to the job in a pickup truck and carried by two men. Contractors can pick up tank, pipe and fittings in one trip, and install the tank on schedule because there's no waiting for the tank to be delivered. Because our polyethylene septic tanks are rotationally molded they are seamless and water tight with no joints or seams to leak.

Model:	Gal.	Len.	Wid.	Ht.
T6020N	300	Sphere	54"	51"
T6026N	500	101"	51"	42"
T6036N	1000	102"	60"	58"
T6044N	1500	133"	55"	66"



Pickup Truck Tanks

Model:	Gal.	Dia.	Ht.	Lid
T0904N	210	60"/51"	28"	8"
T0908N	325	62"	32"	8"
T6036N	425	65"	37"	8"

Open Top Cylindrical Tanks



Model:	Gal.	Dia.	Ht.	Cover#
T60199C	7	10"	21"	T60199CA
T60240C	15	15"	19"	T60240CA
T60260C	17	18"	15"	T60260CA
T60280C	30	18"	29"	T60280CA
T60320C	36	15"	48"	T60320CA
T60360C	55	23"	34"	T60360CA
T60400C	70	24"	36"	T60400CA
T60440C	90	24"	48"	T60440CA
T60480C	100	28"	42"	T60480CA
T60561C	125	36"	30"	T60561CA
T60600C	150	31"	48"	T60600CA
T60680C	210	36"	48"	T60680CA
T60720C	275	42"	48"	T60720CA
T60500C	330	45"	48"	T60500CA
T60520C	360	48"	48"	T60520CA
T60530C	500	52"	60"	T60530CA
T60540C	600	48"	84"	T60540CA
T60560C	1200	69"	84"	T60560CA

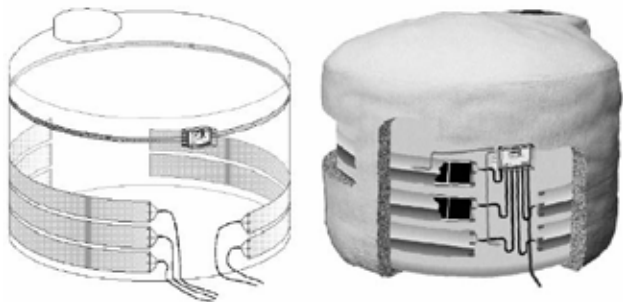

Keep your liquids at nominal temperature this winter. Custom heat tracing panels can be installed to virtually any size tanks. Latex mastic coating is applied to the external tank surface to achieve the correct "R" value. Call Today for pricing and availability.



Complete Cone Bottom Mix Tanks
With steel support stands, mixer support brackets and 115V mixer with 316 stainless steel shaft and propeller.

The tank features a cover assembly and outlet for complete drainage. The stand allows 16" clearance from the bottom of the tank outlet to the floor. Our 115V mixer is standard with a 1/3 HP electric motor, on-off switch, 8' electric cord with plug, 316 stainless steel shaft and 4" impeller.

Complete Mix Stations

Model:	Gal.	Dia.	Ht.
Mix35	35	26"	43"
Mix55	55	26"	55"
Mix100	100	22"	60"
Mix147	147	33"	69"
Mix250	250	44"	56"
Mix500	500	55"	80"

Cone Bottom Tanks

Model:	Gal.	Dia.	Ht.
T2008N	35	23"	27"
T2530C	55	22"	36"
T2540C	100	30"	36"
T2550U	147	31"	53"
T2560C	250	42"	46"
T2570C	500	52"	64"

Support Stands w/Agitator Mounts

Model:	Gal.
ST6309	35
ST6580	55
ST6582	100
ST6584	147
ST6588	250
ST6590	500



Advantage!TM



Horizontal Tank Bands

Model:	Tank	Req.	Wid.	Ht.
ST6010	35	2	19"	19"
ST6020	65	2	22.25"	22.25"
ST6030	125	2	31.25"	31.25"
ST6040	225	2	36.75"	36.75"
ST6040	325	2	36.75"	36.75"
ST6210	425	2	47.50"	47.50"
ST6210	525	2	47.50"	47.50"
ST6010	725	3	47.50"	47.50"
ST6130	1035E	3	77"	48"
ST6210	1025	4	47.50"	47.50"
ST6222	1325	3	64"	65"
ST6300	1625	4	60.75"	60.75"
ST6260	1635E	4	68"	51"
ST6303	2035E	4	82"	49"
ST6301	2635E	4	87.50"	65.25"
ST6301A	3135E	4	85.50"	74"
ST6301B	4035E	4	89"	75"
ST6301C	5025	5	89.50"	90"

Horizontal Tank Bases

Model:	Tank	Len.	Wid.
ST6080	35		
ST6085	65		
ST6090	125		
ST6095	225		
ST6100	325	64"	42.75"
ST6110	525	67"	53.75"
ST6120	725	96"	53.25"
ST6140	1035E	83"	83.75"
ST6200	1025	133"	53.75"
ST6233	1325	99"	66"
ST6241	2035E	142"	84"
ST6250	2635E	140"	92"

Elliptical Tank Skids

Model:	Size	Base	Dim	# Bands
ST6603	200	24"	57"	2
ST6605	300	34"	54"	2
ST6610	500	34"	68"	3
ST6615	750	38"	78"	3
ST6620	1000	46"	72"	3

Cone Bottom Stands

Model:	Fits Tank	Dia.	Clearance
ST6308	15		
ST6309	35		
ST6309B	60		
ST6309AS	30 & 60		
ST6309C	85 & 110	96"	11"
ST6309A	1000 & 1490		
ST6310	2500 & 3000	96"	11"
ST6315	5500	120"	12"
ST6317	6000	102"	12"
ST6318	7500	142"	0"
ST6311A	150	36"	12"
ST6314A	4900	102"	11"
ST6317A	6000	102"	12"

Custom Herbicide Spray Equipment:

All welded unitized aluminum structure--Poly Nurse Tanks w/ baffles and agitation--Chemical Injection Systems available--Complete in-cab operation (Mid-Tech TASC 6300)
 Custom Tool Boxes w/interior shelving--LED lighting and Safety Strobes--Adjustable Road-Side Boom (removable for RH or LH spraying)--Front Bumper Spray Boom w/Curb and Gutter Sprayer--Remote EPA vacuum Overhead Fill Valve--Honda Powered Centrifugal Pump--Electric Rewind Hose Reel for manual applications.



Fiberglass Tanks & Accessories



Heavy Duty Fiberglass Tanks

- White Gel-Coat Finish
- Complete w/Lid & Rim
- Premium Grade Resins
- 3/8" Mounting Studs

Model:	Gallons	Description	L x W x H Dimensions	Fill Opening
T9048T	35	Standard	28 x 23 x 21	8" Lid
T9054FRP	50	Standard	39 x 23 x 21	8" Lid
T9062FRP	100	Standard	39 x 33 x 23	16" Lid
T9072T	100	Drop Tank	67 x 20 x 20	12" Lid
T9100FRP	200	Standard	62 x 39 x 30	16" Lid
T9095T	200	Drop Tank	85 x 28 x 22	16" Lid
T9110T	300	Standard	62 x 39 x 34	16" Lid
T9068T	100	50/50 Split	39 x 33 x 23	2 - 8" Lids
T9088J	200	100/100 Split	62 x 39 x 30	2 - 16" Lids
T9119J	300	200/100 Split	62 x 39 x 34	2 - 16" Lids



Tank Bulk Head Fittings

Model:	Size:	Model:	Size:
TA1199	1/2"	TA1205	1-1/2"
TA1200	3/4"	TA1206	2"
TA1201	1"	TA1209	3"
TA1203	1-1/4"		



4-Bolt Bulk Head Fittings

Model:	Size:	Model:	Size:
TA3020	1"	BBF200BD	2"
TA3030	1-1/2"	BBF300BD	3"
TA3040	2"	(Bottom Drain Fitting)	
TA3050	3"		



Threaded Tank Lids

Model:	Size:	Description:
TL4000	5"	5" Lid w/Vent
TL4200	8"	8" Lid w/Vent & Rim
TL6015	10"	10" Lid w/Vent
TL6016	10"	10" Rim Only



Threaded Tank Lids

Model:	Size:	Description:
TL5527	12"	12" Lid w/Vent & Rim
TL4700	16"	16" Lid w/Vent & Rim
TL5025	4"	4" Center Vent Cap



Tank Strainer Baskets

Model:	Size:	Description:
TL3050	8"	8" Strainer Basket
TL3052	10"	10" Strainer Basket
TL3051	16"	16" Strainer Basket



Stainless Lid Lock Assembly

Model:	Size:	Description:
CCILIDLOCK	16"	16" Locking Assy. Stainless Steel

Valves



Sch. 80 PVC Threaded Ball Valves

Model:	Size:	Model:	Size:
V130	1/2"	V134	1-1/2"
V131	3/4"	V135	2"
V132	1"		
V133	1-1/4"		

• 235 PSI WOG



Brass Ball Valves (600 PSI WOG)

Model:	Size:	Model:	Size:
V158	1/4"	V162	1"
V159	3/8"	V164	1-1/4"
V160	1/2"	V162A	1-1/2"
V161	3/4"	V163	2"



Banjo Single-Union Ball Valve

Model:	Size:	Model:	Size:
BUV050FP	1/2"	BUV150FP	1-1/2"
BUV075FP	3/4"	BUV200FP	2"
BUV100FP	1"		
BUV125FP	1-1/4"		

• 100 PSI WOG



Banjo 4-Bolt Ball Valves (100 PSI WOG)

Model:	Size:	Model:	Size:
BV050	1/2"	BV150	1-1/2"
BV075	3/4"	BV200	2"
BV100	1"	BV200FP	2" Full Port
BV125	1-1/4"	BV300FP	3" Full Port



316 Stainless Steel Ball Valves (1000 PSI)

Model:	Size:	Model:	Size:
V332	1/2"	V336	1-1/2"
V333N	3/4"	V337	2"
V334	1"		
V335	1-1/4"		



Banjo 3 Way Ball Valve (100 PSI WOG)

Model:	Size:
BV075SL	3/4"
BV100SL	1"
BV150SL	1-1/2"
BV200SL	2"



Nipple	
Model:	Size:
F4001A	1/8" X CLS
F4000	3/8" X CLS
F4001	1/4" X CLS
F4002	1/4" X 2 1/2"
F4002A	1/4" X 3"
F4002B	1/4" X 4"
F4002C	1/4" X 6"
F4003	1/2" X CLS
F4003D	1/2" X 2"
F4003A	1/2" X 3"
F4003B	1/2" X 4"
F4003C	1/2" X 6"
F4004	3/4" X CLS
F4004A	3/4" X 2"
F4004B	3/4" X 3"
F4004C	3/4" X 4"
F4004D	3/4" X 6"
F4004H	3/4" X 10"
F4004I	3/4" X 16"
F4005	1" X CLS
F4005A	1" X 2"
F4006B	1" X 3"
F4006	1" X 4"
F4006C	1" X 6"
F4006D	1" X 8"
F4006G	1" X 10"
F4006E	1" X 11"
F4006A	1" X 12"
F4007	1 1/4" X CLS
F4007A	1 1/4" X 2"
F4007B	1 1/4" X 3"
F4007C	1 1/4" X 4"
F4007D	1 1/4" X 6"
F4007E	1 1/4" X 8"
F4007F	1 1/4" X 10"
F4009	1 1/2" X CLS
F4010	1 1/2" X 2"
F4009A	1 1/2" X 2 1/2"
F4010C	1 1/2" X 4"
F4011	2" X CLS
F4011A	2" X 4"
F4011B	2" X 6"
F4011C	2" X 8"
F4011D	2" X 10"
F4011H	2" X 24"
F4012	3" X CLS
F4012C	3" X 6"



King Nipple	
Model:	Size:
F4014	1/4"
F4014A	3/8"
F4015	1/2"
F4016	3/4"
F4017	1"
F4018	1 1/4"
F4019	1 1/2"
F4020	2"
F4022	3"



Coupling	
Model:	Size:
F4022D	1/8"
F4023A	1/4"
F4023	3/8"
F4025	1/2"
F4026	3/4"
F4027	1"
F4028	1 1/4"
F4029	1 1/2"
F4030	2"
F4032	3"
F4032B	4"



Street Elbow	
Model:	Size:
F4060	1/4"
F4060A	3/8"
F4061	1/2"
F4062	3/4"
F4063	1"
F4064	1 1/4"
F4065	1 1/2"
F4066	2"
F4068	3"



Tees	
Model:	Size:
F4050	1/4"
F4050A	3/8"
F4051	1/2"
F4052	3/4"
F4053	1"
F4054	1 1/4"
F4055	1 1/2"
F4056	2"
F4056A	3"



90 Deg. Elbow	
Model:	Size:
F4033A	1/8"
F4033	1/4"
F4034	3/8"
F4035	1/2"
F4036	3/4"
F4037	1"
F4038	1 1/4"
F4039	1 1/2"
F4040	2"
F4040B	3"



Plug	
Model:	Size:
F4089	1/8"
F4090	1/4"
F4090A	3/8"
F4091	1/2"
F4092	3/4"
F4093	1"
F4094	1 1/4"
F4095	1 1/2"
F4096	2"
F4096A	3"



Reducer Bushing

Model:	Size:
F4073	1/4" X 1/8"
F4075	3/8" X 1/8"
F4072	3/8" X 1/4"
F4074	1/2" X 1/8"
F4071	1/4" X 1/2"
F4070	1/2" X 3/8"
F4077	3/4" X 1/4"
F4075A	3/4" X 3/8"
F4076	3/4" X 1/2"
F4079A	1" X 1 1/4"
F4079B	1" X 3/8"
F4080	1" X 1/2"
F4078	1" X 3/4"
F4079	1 1/4" X 3/4"
F4080A	1 1/4" X 1"
F4082C	1 1/2" X 1/4"
F4082B	1 1/2" X 3/4"
F4082	1 1/2" X 1"
F4083	1 1/2" X 1"
F4081A	2" X 1/2"
F4081	2" X 3/4"
F4085	2" X 1"
F4084A	2" X 1 1/4"
F4084	2" X 1 1/2"
F4086	3" X 2"



45 Deg. Elbow

Model:	Size:
F4041A	1/4"
F4041	1/2"
F4042	3/4"
F4043	1"
F4044	1 1/4"
F4045	1 1/2"
F4046	2"
F4022	3"



Cross

Model:	Size:
F4058	1/4"
F4058A	1/2"
F4059A	3/4"
F4059	1"
F4059C	1 1/2"
F4057	2"



Cap

Model:	Size:
F4097A	1/2"
F4097	3/4"
F4097B	1"
F4097C	1 1/4"
F4097D	1 1/2"
F4098	2"



Union

Model:	Size:
F4099D	3/4"
F5000	1"
F4099A	1 1/4"
F5001	1 1/2"
F4099	2"

Pro Series Lawn Care Spray Equipment:

- All welded unitized aluminum structure--
- Painted aluminum on-deck tool boxes--
- Long lasting fiberglass nurse and drop tanks--
- Custom interior shelving--
- LED lighting--
- Aluminum diamond plate deck--
- Curbside operator controls--
- Aluminum roll-up overhead doors on tool boxes--
- Remote actuated overhead fill valves--
- Advertising space on roll up doors--





Nipple

Model:	Size:
BNIP038-SH	3/8" X Short
BNIP050-SH	1/2" X Short
BNIP050-3	1/2" X 3"
BNIP075-SH	3/4" X Short
BNIP075-4	3/4" X 4"
BNIP075-6	3/4" X 6"
BNIP100-SH	1" X Short
BNIP100-4	1" X 4"
BNIP100-6	1" X 6"
BNIP125-SH	1 1/4" X Short
BNIP125-4	1 1/4" X 4"
BNIP125-6	1 1/4" X 6"
BNIP150-SH	1 1/2" X Short
BNIP150-3	1 1/2" X 3"
BNIP150-4	1 1/2" X 4"
BNIP150-5	1 1/2" X 5"
BNIP150-6	1 1/2" X 6"
BNIP200-SH	2" X Short
BNIP200-4	2" X 4"
BNIP200-6	2" X 6"
BNIP300-SH	3" X Short
BNIP300-4	3" X 4"
BNIP300-6	3" X 6"
BNIP400-SH	4" X Short



Reducer Nipple

Model:	Size:
BRN050-038	1/2" X 3/8"
BRN075-050	3/4" X 1/2"
BRN100-050	1" X 1/2"
BRN100-075	1" X 3/4"
BRN125-075	1 1/4" X 3/4"
BRN125-100	1 1/4" X 1"
BRN150-100	1 1/2" X 1"
BRN150-125	1 1/2" X 1 1/4"
BRN200-125	2" X 1 1/4"
BRN200-150	2" X 1 1/2"
BRN300-200	3" X 2"



Hose Barbs - Straight

(Note: the first dimension is NPT thread and the second is the Hose Size.)

Model:	Size:
BHB025	1/4" X 1/4"
BHB025/038	1/4" X 3/8"
BHB038	3/8" X 3/8"
BHB038/050	3/8" X 1/2"
BHB050/038	1/2" X 3/8"
BHB050	1/2" X 1/2"
BHB050/075	1/2" X 3/4"
BHB075/038	3/4" X 3/8"
BHB075/050	3/4" X 1/2"
BHB075/058	3/4" X 5/8"
BHB075	3/4" X 3/4"
BHB075/100	3/4" X 1"
BHB100/075	1" X 3/4"
BHB100	1" X 1"
BHB100/125	1" X 1 1/4"
BHB125/075	1 1/4" X 3/4"
BHB125/100	1 1/4" X 1"
BHB125	1 1/4" X 1 1/4"
BHB125/150	1 1/4" X 1 1/2"
BHB150/100	1 1/2" X 1"
BHB150/125	1 1/2" X 1 1/4"
BHB150	1 1/2" X 1 1/2"
BHB150/200	1 1/2" X 2"
BHB200/150	2" X 1 1/2"
BHB200	2" X 2"
BHB300	3" X 3"
BHB400	4" X 4"



Cross

Model:	Size:
BCR075	3/4"
BCR100	1"
BCR125	1 1/4"
BCR150	1 1/2"
BCR200	2"



Coupling

Model:	Size:
BCPLG038	3/8"
BCPLG050	1/2"
BCPLG075	3/4"
BCPLG100	1"
BCPLG125	1 1/4"
BCPLG150	1 1/2"
BCPLG200	2"
BCPLG300	3"



Pipe Plug

Model:	Size:
BPLUG050	1/2"
BPLUG075	3/4"
BPLUG100	1"
BPLUG125	1 1/4"
BPLUG150	1 1/2"
BPLUG200	2"
BPLUG300	3"



Reducer Coupling

Model:	Size:
BRC100-075	1" X 3/4"
BRC150-100	1 1/2" X 1"
BRC150-125	1 1/2" X 1 1/4"
BRC200-100	2" X 1"
BRC200-125	2" X 1 1/4"
BRC200-150	2" X 1 1/2"
BRC300-200	3" X 2"



Hose Barb - 90 Deg.

(Note: the first dimension is NPT thread and the second is the Hose Size.)

Model:	Size:
BHB-025-90	1/4" X 1/4"
BHB-038-90	3/8" X 3/8"
BHB-050/038-90	1/2" X 3/8"
BHB-050-90	1/2" X 1/2"
BHB-050/075-90	1/2" X 3/4"
BHB-075/050-90	3/4" X 1/2"
BHB-075-90	3/4" X 3/4"
BHB-075/100-90	3/4" X 1"
BHB-100/075-90	1" X 3/4"
BHB-100-90	1" X 1"
BHB-100/125-90	1" X 1 1/4"
BHB-125/100-90	1 1/4" X 1"
BHB-125-90	1 1/4" X 1 1/4"
BHB-150-90	1 1/2" X 1 1/2"
BHB-200-90	2" X 2"
BHB-300-90	3" X 3"



Hose Barb Tee

Model:	Size:
BHT-050-038	1/2" X 1/2" X 3/8"
BHT-050-075	1/2" X 1/2" X 3/4"
BHT-075-050	3/4" X 3/4" X 1/2"
BHT-075	3/4"
BHT-100-075	1" X 1" X 3/4"
BHT-100	1"



Reducer Bushing

Model:	Size:
BRB038-025	3/8" X 1/4"
BRB050-025	1/2" X 1/4"
BRB050-038	1/2" X 3/8"
BRB075-018	3/4" X 1/8"
BRB075-025	3/4" X 1/4"
BRB075-038	3/4" X 3/8"
BRB075-050	3/4" X 1/2"
BRB100-018	1" X 1/8"
BRB100-025	1" X 1/4"
BRB100-050	1" X 1/2"
BRB100-075	1" X 3/4"
BRB125-075	1 1/4" X 3/4"
BRB125-100	1 1/4" X 1"
BRB150-075	1 1/2" X 3/4"
BRB150-100	1 1/2" X 1"
BRB150-125	1 1/2" X 1 1/4"
BRB200-075	2" X 3/4"
BRB200-100	2" X 1"
BRB200-125	2" X 1 1/4"
BRB200-150	2" X 1 1/2"
BRB300-150	3" X 1 1/2"
BRB300-200	3" X 2"



Street Elbow 90

Model:	Size:
BSL038-90	3/8"
BSL050-90	1/2"
BSL075-90	3/4"
BSL100-90	1"
BSL125-90	1 1/4"
BSL150-90	1 1/2"
BSL200-90	2"
BSL300-90	3"



Hose Barb to Hose Barb

Model:	Size:
BHM050	1/2" X 1/2"
BHM075	3/4" X 3/4"
BHM100	1" X 1"
BHM125	1 1/4" X 1 1/4"
BHM150	1 1/2" X 1 1/2"
BHM200	2" X 2"
BHM300	3" X 3"



Pipe Tee

Model:	Size:
BTEE038	3/8"
BTEE050	1/2"
BTEE075	3/4"
BTEE100	1"
BTEE125	1 1/4"
BTEE150	1 1/2"
BTEE200	2"
BTEE300	3"



Pipe Elbow 90

Model:	Size:
BEL050-90	1/2"
BEL075-90	3/4"
BEL100-90	1"
BEL125-90	1 1/4"
BEL150-90	1 1/2"
BEL200-90	2"
BEL300-90	3"



Pipe Cap

Model:	Size:
BCAP075	3/4"
BCAP100	1"
BCAP150	1 1/2"
BCAP200	2"
BCAP300	3"



Hose Barb 90

Model:	Size:
BHBEL-100-90	1"



Flange Clamps



Model:	Size:
BFC100	1" FP
BFC200	2" SP
BFC220	2" FP
BFC300	3" FP

Flange x 90 Hose Barb Elbow



Model:	Size:
BM100BRB90	1"
BM200BRB90	2" SP
BM220BRB90	2" FP
BM300BRB90	3"

Flange Gaskets



Model:	Size:
B100G	1"
B150G	2" SP
B200G	2" FP
B300G	3" FP

Flange x Hose Barb



Model:	Size:
BM100BRB	1"
BM200BRB	2" SP
BM220BRB	2" FP
BM300BRB	3"

Flanged Poly Check Valves



Model:	Size:
BMCV100	1"
BMCV200	2"
BMCV220	2" FP

Flanged Cross



Model:	Size:
BM100CR	1"
BM200CR	2" SP
BM220CR	2" FP
BM300CR	3"

Flange x Male NPT Thread



Model:	Size:
BM100MPT	1"
BM200MPT	2" SP
BM220MPT	2" FP
BM300MPT	3"

90 Deg Flanged Coupling



Model:	Size:
BM100CPG90	1"
BM200CPG90	2" SP
BM220CPG90	2" FP
BM300CPG90	3"

Flange x Female NPT Thread



Model:	Size:
BM100FPT	1"
BM200FPT	2" SP
BM220FPT	2" FP
BM300FPT	3"

2" Full Port Stubby Valve



Model:	Size:
BMVS220CF	2" FP

Flanged Tee



Model:	Size:
BM100TEE	1"
BM200TEE	2" SP
BM220TEE	2" FP
BM300TEE	3"

4 & 6 Bolt Valves



Model:	Size:
BMV100CF	1"
BMV200CF	2" SP
BMV220CF	2" FP
BMV300CF	3" FP

Flanged Couplings



Model:	Size:
BM100CPG	1"
BM200CPG	2" SP
BM220CPG	2" FP
BM300CPG	3"

Flanged Tee



Model:	Size:
BM100CPG45	1"
BM220CPG45	2" FP
BM300CPG45	3"

Line Strainers



Model:	Size:
BMLS200-12	2"
BMLS222-16	2" FP
BMLS300-12	3"

Flange x Male NPT Thread SS



Model:	Size:
BM220MPTSS	2" FP
BM300MPTSS	3"

Cam Action Couplers

Type "A" Female Pipe x Male Cam-Lock

	Model: Size:	Model: Size:
	B075A 3/4"	B200A 2"
	B100A 1"	B300A 3"
	B125A 1-1/4"	
	B150A 1-1/2"	

Type "B" Male Pipe x Female Cam-Lock

	Model: Size:	Model: Size:
	B075B 3/4"	B200B 2"
	B100B 1"	B300B 3"
	B125B 1-1/4"	
	B150B 1-1/2"	

Type "C" Hose x Female Cam-Lock

	Model: Size:	Model: Size:
	B075C 3/4"	B200C 2"
	B100C 1"	B300C 3"
	B125C 1-1/4"	
	B150C 1-1/2"	

Type "D" Female Pipe x Female Cam-Lock

	Model: Size:	Model: Size:
	B075D 3/4"	B150D 1-1/2"
	B100D 1"	B200D 2"
	B125D 1-1/4"	B300D 3"

Type "E" Hose x Male Cam-Lock

	Model: Size:	Model: Size:
	B075E 3/4"	B200E 2"
	B100E 1"	B300E 3"
	B125E 1-1/4"	
	B150E 1-1/2"	

Type "F" Male Pipe x Male Cam-Lock

	Model: Size:	Model: Size:
	B075F 3/4"	B200F 2"
	B100F 1"	B300F 3"
	B125F 1-1/4"	
	B150F 1-1/2"	

Type "PL" Male Cam-Lock Plug

	Model: Size:	Model: Size:
	B075PL 3/4"	B200PL 2"
	B100PL 1"	B300PL 3"
	B150PL 1-1/2"	

Type "CAP" Male Pipe x Male Cam-Lock

	Model: Size:	Model: Size:
	B075CAP 3/4"	B200CAP 2"
	B100CAP 1"	B300CAP 3"
	B150CAP 1-1/2"	

Type "90°A" Female Pipe x Male Cam-Lock

	Model:	Size:
	N150A90	1-1/2" 90° A Coupler
	N200A90	2" 90° A Coupler

Type "90°C" Hose x Female Cam-Lock

	Model:	Size:
	N150C90	1-1/2" 90° C Coupler
	N200C90	2" 90° C Coupler

Type "90°D" Female Pipe x Female Cam-L

	Model:	Size:
	N150D90	1-1/2" 90° D Coupler
	N200D90	2" 90° D Coupler

Type "90°F" Male Pipe x Male Cam-Lock

	Model:	Size:
	N150F90	1-1/2" 90° F Coupler
	N200F90	2" 90° F Coupler

No-Spill Dry Disconnects

Sure Stop™ Full-Flow Dry Disconnect

	Model:	Size:
	BDB100	1" FPT Complete Coupler M/F
	BDB100M	1" FPT Male Coupler
	BDB100F	1" FPT Female Coupler

Banjo Dry-Mate™ Dry Disconnects

	Model:	Size:
	BDM150A	1-1/2" Male Dry-Mate x FPT
	BDM150D	1-1/2" Female Dry-Mate x FPT
	BDM200A	2" Male Dry-Mate x FPT
	BDM200D	2" Female Dry-Mate x FPT

Back Pack & Spot Sprayers

Back Pack & Yard Tender Sprayers

	Model:	
	FSPS0010	• Yard Tender
	FSPS003	• SP Systems SP1
	FSPS002	• SPO-V Knap Sack
	FSPS007	• Estate Keeper

Back Pack & Yard Tender Sprayers

Model:	
FSPS1352	• Yard Tender
FSPS010960001	• Birchmeer Iris Pro



Flow Meters



Badger Mag Meters

Model: Description:
DI2152KIT • 2" Meter w/reset
• Teflon Liner



Sotera Digital Flow Meter 2-20 GPM

Model: Description:
MS825 • Easy read LCD display
• Polypropylene body with a Ryton chamber & chemical seal
• 1" NPT Inlet and Outlet



GPI Digital Flow Meter (Stainless)

Model: Description:
M404 • Stainless 1" - .3 to 3 GPM
M405 • Stainless 1" - 3 to 30 GPM
M406 • Stainless 2" - 30 to 300 GPM



Bulk Flow Meters (Aluminum)

Model: Description:
MS826A • Aluminum 1-1/2" Ports
• 60 GPM Flow
MS826C • Aluminum 2" Ports
• 100 GPM Flow



Banjo Magnetic Flow Meter

Model: Description:
BMFM100 • 1" Magnetic Meter
(Flanged) • Digital
BFM100 • All Poly
(Threaded) • 2-110 GPM Range



Banjo Magnetic Flow Meter

Model: Description:
BMFM220 • 2" Magnetic Meter
(Flanged) • Digital
BMFM220KIT • All Poly
(Threaded) 2" • 30-300 GPM Range



GPI Digital Flow Meter (Nylon)

Model: Description:
M409 • Nylon 1" - .3 to 3 GPM
M409A • Nylon 1" - 3 to 30 GPM
M406A • PVC 2" - 30 to 300 GPM



Bulk Flow Meters (Stainless)

Model: Description:
MS826B • Stainless 2" Ports
• 100 GPM Flow

Pumps



Sotera Diaphragm Transfer Pumps

Model: Description:
MS415 12V • Pump w/Hose
MS460 110V • Max: 13 GPM
• 2" NPT bung Adapter
• Santoprene Diaphragms



Sotera Diaph. Transfer Pumps w/Meters

MS421 12V • Pump / Hose / Meter
MS461 110V • Max: 13GPM
• 2" NP bung adapter
• Santoprene Diaphragms



Sotera Chemtraveller Portable System

Model: Description:
MS435 12V • Pump / Meter / Hoses & Storage Frame
MS465 110V • 9' EPDM Transfer Hose
• Model 825 digital flow meter



2" Pump/Motor/Stand Kits

80PUMPASS25P • 2" Poly, SS, Cast I.
80PUMPASS25SS • 5 hp 3 ph Motors
80PUMPASS25CI • Coupling Guard & Stand
• Single Phase Option



Jet Agitation Eductors

Model: Description:
BX2MP • 3/4" Poly Eductor
BX3MP • 1" Poly Eductor
BX4MP • 1 1/2" Poly Eductor



3" Pump/Motor/Stand Kits

80PUMPASS310P • 2" Poly, SS, Cast I.
80PUMPASS310SS • 5 hp 3 ph motors
80PUMPASS310CI • Coupling Guard & Stand



Sump Pump

Model: Description:
PM13YU75 • 1/2" HP SS w/Float
PM13YU76 • 3/4" HP SS w/Float



Metering Injectors

P0003 • Dosage Rate .2% to 2%
P0002A • Dosage Rate .2% to 1.6%
P0000 • Dosage Rate 2% to 10%
(Please call for application info.)



Equipment for **NEW** or upgrading old systems

- Design and Layout Assistance
- Pre-assembled kit or components only
- Plumbing packages
- Field and site visits



Stainless Steel Work Stations

81MLWORKTABLE1

- 96"l x 60"h x 30"w
- Stainless Sink
- PVC Deck & Splash

81MLWORKTABLE



Aluminum Storage Shelving

81MLSHELF3

- 96"l x 60"h x 18"w
- 1200 lb rated
- Aluminum Frame



Emergency Eyewash Showers

CCIFSG1600S • All Stainless Steel
Wall Mount
CCIFSG1600S-A
Floor Mount



Sump Boxes / Grates & Covers

80SUMPBOX222SS1
w/ 2-1" x 1 1/2" fittings

80SUMPBOX222SS
w/ no fittings



80GRATETEC22SSNF
cover w/ no fittings

80GRATEC22SS
w/ 3" coupling boot

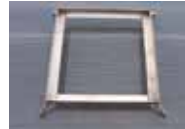

80GRATEFR22
2" Frame for concrete

Chemical Pre-Mix Tank Systems



80110MNF	110 Gallon
80220MNF	220 Gallon
80300MNF	300 Gallon
w/ pump tank eductor kit	
80500CBMNF DL	500 Gallon
80750CBMNF DL	750 Gallon
801050CBMNF DL	1050 Gallon

Chemical Eductors

Add chemicals, dry products into
spray and mix tanks

80EDUCTORBJ10	10 Gallon
80EDUCTOR BJ15	15 Gallon
80EDUCTORBJ35	35 Gallon

With Bypass Agitation
All Stainless Framing



Retractable Loadout Hose Kits

Load Out Swing Arms
for filling



Storage - Mixing - Dispensing



- Facility design assistance
- Pre-assembled systems
- In-field site and efficiency evaluations
- Pre-packaged standard kits for multiple sites

- Complete turn key systems small or large
- Manual or automated systems
- Individual components
- Upgrades to expand existing facilities

Eductor kits



- Features:
- Stainless Frame
 - Poly Cone bottom tanks
 - By Pass
 - Hose Barbs

80EDUCTORBJ10
80EDUCTORBJ15
80EDUCTORBJ35

Pump kits

Includes: 3ph motor, SS stand w/legs, guard, couplings



- 2" Cast Iron, Stainless Steel or Poly centrifugal pumps w/ viton seals
- 3" Cast Iron or Stainless Steel centrifugal pumps w/viton seals

80PUMPASS25CI
80PUMPASS25SS
80PUMPASS25P
80PUMPASS310CI
80PUMPASS310SS

Available in single phase

Flow Meters



- 2" Mag-meter, Teflon liner
- 2" FPT Threaded flange
- Re-setable
- Requires 110v power

DI2152KIT

Pump fitting Kits

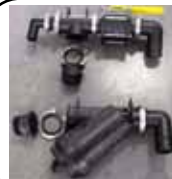

- 80PLUMBKIT • 2" Suction, 2" Discharge manifold fittings, valve
- 80PLUMBKIT3 • 3" Suction, 1-3" Discharge 1-2" Discharge, valve

Banjo Mag Meters



- BFM100 • 1" 2-110 gpm rated
- BMF200 • 2" 5-300 gpm rated
- BMF300 • 3" 14-670 gpm rated

Sotera Meters



- MS825 • 1" 2.20 gpm rated
- MS826C • 2" Aluminum
- MS826B • 2" Stainless Steel

Bag Filters



Sump Covers



Sump Boxes



Mix-n-Fill Chemical Pre-Mix Tank kits



Features:

- 400 Series 110 v Sotera Diaphragm Pump
- Heavy duty cone bottom mini-bulk style tank w/ fork pockets* & 8" access lid
- 12' chemical transfer discharge hose w/nozzle valve & holder
- Simple selector valve to set in mix or dispense operation.
- Vortex jet agitation system for complete mixing of product before dispensing
- 10-15 gpm flow rate*/electric
- 10-30 gpm flow rate*/ air (optional)
- On/off switch with overload protection
- 6' 3 wire 110 volt cord w/ plug
- 2" access fitting for water fill optional water meter kit adders

Pump may run dry without damage

Larger Sizes Available

Tanks

80110MNF	110 Gallon 110V pump (44" wide x 43" ht)
80220MNF	220 Gallon 110V pump (44" wide x 67" ht)
80300MNF	300 Gallon 110V pump (49" wide x 73"ht)

Larger Sizes: Cone Bottom Tank w/Pump/Eductor Kit

80500MNF DL	500 Gallon
80750MNF DL	750 Gallon
801050MNF DL	1050 Gallon

Optional Pump Available

Customized Tank Mixing & Pumping Systems Available



Jet Agitation Nozzles

Water Meters	Adder/inlet only (Optional)
MNFKITA	1" Meter Kit / 20 gpm
MNFKITB	2" Meter Kit/30-200 gpm

Electronic Pre-set Dosage Device for Chemical Transfer



80QUANTOFILLAHV
80QUANTOFILLALV

80QUANTOFILL12V
80QUANTOFILL110
(Meter & Control box only-
no pump, no plumbing)

- Transfers pre-set amount and shuts off
- HV transfer maximum rate 12 GPM
- LV transfer maximum rate 3 GPM
- Units of measure, oz,ml,gallons
- 110 volt power
- For drums,minibulks & tanks
- Also available in 12 volt/ multi-unit combinations

Multi Chemical Transfer Kits



Sotera 400 series pump, 825 digital manual resettable flow meter, 10-12 gpm transfer rate, stainless mounting stand/legs, plumbing kits for combination plumbing kits for 1, 2 or 4 outlets, 1 or 2 inlet ports

80MCTS11
80MCTS21
80MCTS42

1-inlet w/ drum stinger & 2" female QC for minibulk tank hook-up, 1-12' discharge hose w/ ball valve & nozzle



Equipment Wash Depot Systems



Enclosed Reclaim

Ozone, Biological & Hydro-Aeration/Filtration Provides Primary Water Treatment

- All aluminum construction
- Higher water volume processing rates
- Complete enclosed skids



Open Reclaim



Discharge



Wash Reels

Containment / Wash Pads



- Variety of lengths & widths
- Center and side drains
- Aluminum and steel construction



Self Contained Chemical Buildings

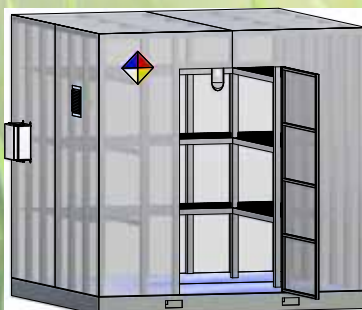

- Standard or custom built sizes
- All Aluminum construction



Water Filter Kits



Conventional Tank Design

Standard Features:

- Chemical Resistant Polyethylene Tanks
- Large Fill-Well for Easy Access
- All Welded Corrosion Resistant T6061 Aluminum Frame
- Remote Mounted Suction Strainer w/Tank On/Off Valve
- All Plumbing is Poly or Stainless Steel
- Easy Start Honda Engines
- Commercial Duty Pumps
- Adjustable High Pressure Jet Agitation
- Low Profile Tank Design
- Premium Grade Spray Hose
- Easy Access Frame for Regular Maintenance
- Liquid Filled Pressure Gauge
- Factory Tested & Ready for Operation

Single Tank Skids

Part Number	Tank and Pump (gpm,psi)	Engine
7SLP050-CR-160	50 Gallon, Roller Pump	Honda GX160 Man.
7SLP050-CR-160E	50 Gallon, Roller Pump	Honda GX160 Elec.
7SLP100-CR-160	100 Gallon, Roller Pump	Honda GX160 Man.
7SLP100-CR-160E	100 Gallon, Roller Pump	Honda GX160 Elec.
7SLP050-K43-160	50 Gallon, K-43 (10.5, 560)	Honda GX160 Man.
7SLP050-K43-160E	50 Gallon, K-43 (10.5, 560)	Honda GX160 Elec.
7SLP100-K43-160	100 Gallon, K-43 (10.5, 560)	Honda GX160 Man.
7SLP100-K43-160E	100 Gallon, K-43 (10.5, 560)	Honda GX160 Elec.
7SLP100-K55-240	100 Gallon, K-55 (15, 560)	Honda GX240 Man.
7SLP100-K55-240E	100 Gallon, K-55 (15, 560)	Honda GX240 Elec.
7SLP200-K55-240	200 Gallon, K-55 (15, 560)	Honda GX240 Man.
7SLP200-K55-240E	200 Gallon, K-55 (15, 560)	Honda GX240 Elec.
7SLP300-K55-240	300 Gallon, K-55 (15, 560)	Honda GX240 Man.
7SLP300-K55-240E	300 Gallon, K-55 (15, 560)	Honda GX240 Elec.
7SLP200-K75-390	200 Gallon, K-75 (20, 560)	Honda GX390 Man.
7SLP200-K75-390E	200 Gallon, K-75 (20, 560)	Honda GX390 Elec.
7SLP300-K75-390	300 Gallon, K-75 (20, 560)	Honda GX390 Man.
7SLP300-K75-390E	300 Gallon, K-75 (20, 560)	Honda GX390 Elec.
7SLP400-K75-390	400 Gallon, K-75 (20, 560)	Honda GX390 Man.
7SLP400-K75-390E	400 Gallon, K-75 (20, 560)	Honda GX390 Elec.
7SLP500-K75-390	500 Gallon, K-75 (20, 560)	Honda GX390 Man.
7SLP500-K75-390E	500 Gallon, K-75 (20, 560)	Honda GX390 Elec.
7SLP300-K120-670E	300 Gallon, K120 (35, 700)	Honda GX670 Elec.
7SLP400-K120-670E	400 Gallon, K120 (35, 700)	Honda GX670 Elec.
7SLP500-K120-670E	500 Gallon, K120 (35, 700)	Honda GX670 Elec.



Long Profile Tank Design



Spray Rig - Hose Reels/Hose Titan/Hannay

- 7SHR38300M 3/8" Ag Hose 560 PSI 300ft Manual
- 7SHR38300E 3/8" Ag Hose 560 PSI 300ft Electric
- 7SHR12300M 1/2" Ag Hose 560 PSI 300ft Manual
- 7SHR12300E 1/2" Ag Hose 560 PSI 300ft Electric
- 7SHR12300HPE 1/2" Ag Hose 800 PSI 300ft Electric
- 7SHR58300E 5/8" Ag Hose 560 PSI 300ft Electric
- 7SHR58300HPE 5/8" Ag Hose 800 PSI 300ft Electric
- 7SHR34300HPE 3/4" Ag Hose 800 PSI 300ft Electric

Roller Guides Included on Electric Reels
Optional Hose Lengths available





Multi-Tank Skids

Part Number	Tank and Pump (gpm,psi)	Engine
7S10050-K43-160	100/50 Gallon, K-43 (10.5, 560)	Honda GX160 Man.
7S10050-K43-160E	100/50 Gallon, K-43 (10.5, 560)	Honda GX160 Elec.
7S20050-K43-160	200/50 Gallon, K-43 (10.5, 560)	Honda GX160 Man.
7S20050-K43-160E	200/50 Gallon, K-43 (10.5, 560)	Honda GX160 Elec.
7S10050-K55-240	100/50 Gallon, K-55 (15, 560)	Honda GX240 Man.
7S10050-K55-240E	100/50 Gallon, K-55 (15, 560)	Honda GX240 Elec.
7S20050-K55-240	200/50 Gallon, K-55 (15, 560)	Honda GX240 Man.
7S20050-K55-240E	200/50 Gallon, K-55 (15, 560)	Honda GX240 Elec.
7S100100-K55-240	100/100 Gallon, K-55 (15, 560)	Honda GX240 Man.
7S100100-K55-240E	100/100 Gallon, K-55 (15, 560)	Honda GX240 Elec.
7S200100-K55-240	200/100 Gallon, K-55 (15, 560)	Honda GX240 Man.
7S200100-K55-240E	200/100 Gallon, K-55 (15, 560)	Honda GX240 Elec.
7S20050-K75-390	200/50 Gallon, K-75 (20, 560)	Honda GX390 Man.
7S20050-K75-390E	200/50 Gallon, K-75 (20, 560)	Honda GX390 Elec.
7S100100-K75-390	100/100 Gallon, K-75 (20, 560)	Honda GX390 Man.
7S100100-K75-390E	100/100 Gallon, K-75 (20, 560)	Honda GX390 Elec.
7S200200-K75-390	200/200 Gallon, K-75 (20, 560)	Honda GX390 Man.
7S200200-K75-390E	200/200 Gallon, K-75 (20, 560)	Honda GX390 Elec.
7S300100-K75-390	300/100 Gallon, K-75 (20, 560)	Honda GX390 Man.
7S300100-K75-390E	300/100 Gallon, K-75 (20, 560)	Honda GX390 Elec.
7S300100-K120-670E	300/100 Gallon, K120 (35, 700)	Honda GX670 Elec.
7S400100-K120-670E	400/100 Gallon, K120 (35, 700)	Honda GX670 Elec.
7S500100-K120-670E	500/100 Gallon, K120 (35, 700)	Honda GX670 Elec.
7S315-K75-390E	300/100/50 Gallon, K75 (20, 560)	Honda GX390 Elec.
7S325-K75-390E	300/200/50 Gallon, K75 (20, 560)	Honda GX390 Elec.
7S315-K120-670E	300/100/50 Gallon, K120 (35, 700)	Honda GX670 Elec.
7S315-K120-670E	300/100/50 Gallon, K120 (35, 700)	Honda GX670 Elec.
7S425-K120-670E	400/200/50 Gallon, K120 (35, 700)	Honda GX670 Elec.
7S525-K120-670E	500/200/50 Gallon, K120 (35, 700)	Honda GX670 Elec.

See Page 26 for Hose Reels and Hose



Our portable spraying systems are quality engineered and manufactured to provide years of dependable service with low maintenance. Their lightweight portable design makes these units perfect for a wide range of spraying applications.

Chemical Containers, Inc. 6 - 25 Gallon Lawn & Turf Sprayers

Standard Features:

- Chemical Resistant Polyethylene Tank
- Seamless No-Leak Construction
- Quick Drain Fitting for Easy Cleaning
- Calibration Scale Molded into Tank
- Heavy Duty 12V Diaphragm Pump
- Pro-Trigger Spray Gun w/Adjustable Tip
- 5" Fill-Well with Easy Grip Lid
- 25' of 3/8" Chemical Spray Hose
- All Stainless Steel Fasteners
- 9' Wiring Harness w/Battery Clips
- Systems are Factory Tested & Ready for Operation

Models:	Description:	PSI / GPM
CCI6	6 Gallon Spot Sprayer, 25 ft hose, poly gun.	60 • 1.8
CCI14ECO	14 Gallon Spot Sprayer, 25ft hose, poly gun.	60 • 1.0
CCI25ECO	25 Gallon Spot Sprayer, 25ft hose, poly gun.	60 • 1.0
CCI14	14 Gallon Spot Sprayer, 25 ft hose, poly gun.	60 • 1.8
CCI25	25 Gallon Spot Sprayer, 25 ft hose, poly gun.	60 • 1.8
CCI15	15 Gallon Spot Sprayer w/frame, 25 ft hose, poly gun.	60 • 1.8

Custom Built Sprayers:

We specialize in custom built spray rigs. The previous pages of spray skids are suggestions of the many sizes we offer. Call us to configure your spray skid to fit your needs. Our sales force is ready to assist you with experience that spans 35 years.

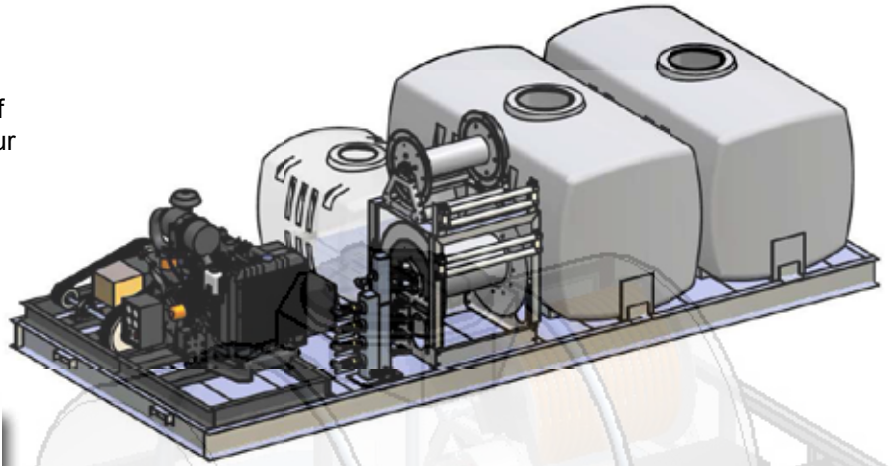

For more information please visit:
www.spraytree.com



Multi-Size Leg Tank Sprayer

- Manual start Honda GX160 4.8HP with Banjo 2"x2" poly self-priming pump
- (Tank size of your choice) leg tank with built in baffles and 16" lid
- All aircraft grade aluminum frame with built in fork lift pockets
- Single lane mile boom 7' aluminum covered Reese plug in boom with 1 1/2" PVC Sch80 boom with quick disconnect fitting to plug into plumbing
- 2 GPM solid stream stainless spray nozzles, (2) Boom Buster nozzles with manual ball valve controls, and BEX clamp bodies for easy removal (Unit can spray 3 lanes)
- Wireless on/off switch for banjo poly heavy duty electric shut off valve (valve has on or off indicator) wire harness w/ quick disconnect plugs
- Stainless steel pressure gauge
- Remote tank fill fitting w/quick coupling fitting to use on board pump to fill unit

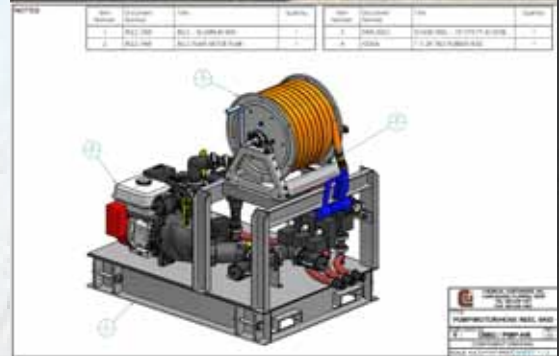

Slide-in Skids

- Electric start Honda GX160 4.8HP with Banjo 2inx2in poly self-priming pump
- 8' Long Boom with Stainless Steel Pipe and fittings. 8 turrets, Boom Busters nozzles and 3 lane MicroTrak controls.
- 2 GPM solid stream stainless spray nozzle, poly covered stainless flat fan nozzles, and poly Tri-Stream nozzles, w/quick caps in a turret nozzle body w/ diaphragm checks
- Cab control for boom with(3) on/ off switches for TeeJet 450 manifold poly heavy duty electric shut off valves, wire harness w/ quick disconnect plugs
- Manifold style poly plumbing (stainless clamped together fittings, easy repair)
- Hannay electric hose reel with 75ft of 3/4" orange AG hose and heavy duty Udor blue adjustable salt gun.
- Remote tank fill fitting w/quick coupling fitting (to use pump to fill unit)
- All Aircraft grade aluminum skid, fork lift pockets, and tie down tabs, complete user's manual and full 1 year warranty



CCI Self-Loading Anti-Ice Systems

CCI Brine Makers



1500 Gallon

- 1500 Gallon square tank with aluminum receiving top for salt loader with all steel frame to protect tank from tip-over after complete empty.
- Unit has 1" eductor nozzles and 3" full port valves for control of all operations.
- Bottom drain for rinsing out materials and adjustable suction ports for dispensing product.
- 10HP 240 volt 3 phase motor with starter and 3" all stainless steel pump and motor producing 340 gallons per minute for agitation and product transfer.
- Salt percentage meter with case.
- Off-load meter.
- Unit will produce 3000 gallons of brine each hour if the unit has sufficient water available.
- Unit includes all hoses needed to hook into current holding tanks, installation instructions, and user manual.



300 Gallon

- 300 Gallon tote tank w/steel frame
- 2HP motor with 1 1/2" stainless steel pump.
- 60 GPM discharge & agitation.
- Unit produces 900 GPH
- Clean out valve
- Tip-over clean out
- Portable with fork pockets

Gas Driven Tote Sprayer



Pump Systems





Chemical Containers Inc. Is your Full Parts and Service Center



Stainless Steel Construction - Tanks, fittings, hardware and plumbing.

Rears Constant Velocity Hitch - Smooth 90 deg turns.

Rears Centrifugal Pumps - 200 psi/80 gpm

Remote Spray Control - manual, electric, hydraulic.

Double Roll-Over Nozzle Bodies - easy application switch.

33" of 38" Diameter Axial Flow Fans - fitted to stainless steel housing.

Electric Fan Clutch - On/Off control for mixing.

Control Systems



3 eyes per side system - installed on a Rears Sprayer.

With the growing cost and new disease challenges in crop production, growers have to take advantage of every opportunity to save time and money while not sacrificing the quality of care provided to crops. Invest in the Patented Technology of Chemical Container's CC-EYE 8000 Tree Sense Control System and allow yourself as a grower to apply precise, accurate applications saving you money and time. Growers who are currently utilizing the CC-EYE 8000 Tree Sense Control System are realizing dramatic reductions in application cost and application time. Contact us today about investing in the CC-EYE 8000 Tree Sense Control System for your sprayer or fertilizer spreader.

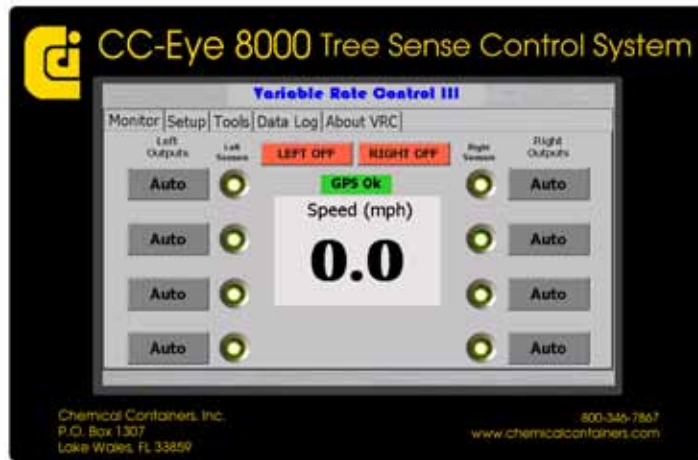

Features:

- Touch Screen Programming- Easily programmable for first time users!
- Our Exclusive "Look Ahead Feature"
 - The CC-EYE 8000 Tree Sense Control System factors in the mechanical delay of the implement while constantly monitoring for changes in the speed of the implement using GPS. When the implement speed changes, the system automatically recalculates the "look ahead distance" to assure that the pre-set application buffer is achieved before and after the target.
- Application Target Buffers
 - Allows users to increase or decrease in one inch increments the distance that the application begins ahead of and continues past the targeted tree.
- Infrared Sensing Eyes can be mounted on implement or tractor.
 - Allows for Growers to use same CC- EYE 8000 Tree Sense Control System controller with multiple implements.
- Capable of storing multiple spray program settings
- Up to 8 zones on sprayers or spreaders
- Patented technology!



3 eyes per side system - installed on a BBI TruSpread



Chemical Containers Commercial Spray Rigs:

- Open or all enclosed body styles.
- All welded unitized aluminum structure with aircraft grade aluminum bodies.
- PTO or Honda driven pumps for Tree and or Lawn spraying applications.
- Structural decking for maximum load capacity.
- Curbside operator controls.
- DOT - LED lighting and safety strobe lights.
- ROM aluminum locking roll-up doors.
- Custom interior shelving and dividers.
- High pressure jet agitation available.
- Stainless steel control manifolds.
- Epoxy primer coat with automotive final paint coat.
- Complete user's manual and Full 1 year warranty



REVISION HISTORY		
NO.	DESCRIPTION	DATE

For more information please visit:
www.spraytree.com

PLEASE REPORT INCLUDING MODEL, MAKE, YEAR, ETC. TO CONTACT SALES

Call: 800-346-7867
 Website: www.spraytree.com
 Fax: 772-465-1440
 Email: info@spraytree.com



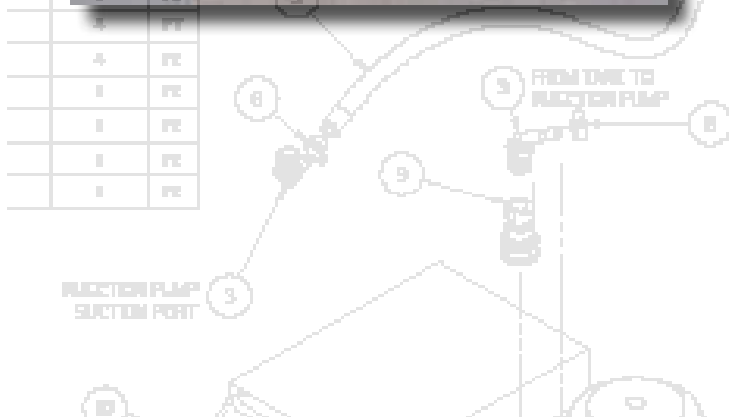

Chemical Containers Custom Herbicide Spray Equipment

- All welded unitized aluminum structure with aircraft grade aluminum bodies.
- Poly nurse tanks w/baffles and agitation.
- Chemical injection systems available.
- Complete in-cab operation (Mid-Tech TASC 6300 available).
- Custom tool boxes with interior shelving.
- LED lighting and safety strobes.
- Adjustable road-side boom (removable for LH or RH spraying).
- Front bumper spray boom with curb and gutter sprayer.
- Remote EPA vacuum overhead fill valve
- Honda powered centrifugal pump.
- Electric rewind hose reel for manual applications.
- Complete user's manual and Full 1 year warranty





Chemical Containers Custom Rail Sprayers

Complete line of herbicide sprayers specifically designed for railroad spraying.

- 2000 and 3000 gallon welded aluminum bodies
- 550 and 750 gal crossing sprayers
- Tee-Jet Aeros controller w/ mapping
- 50' from center of truck spray coverage
- Chemical storage
- Metered transfer of chemical to spray tank
- Injection systems



Chemical Containers Custom Ag Equipment

Complete line of agricultural sprayers including:

- Citrus sprayers
- Row crop sprayers
- Nursery sprayers
- Fertilizer spreaders
- Herbicide booms
- Bulk fertilizer tank farms
- Injection systems

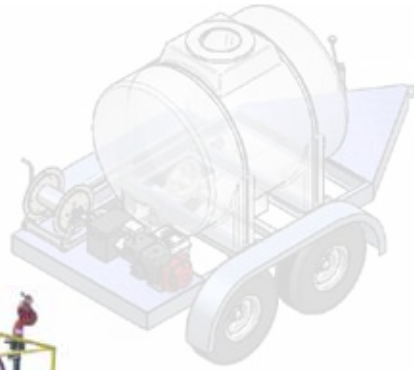

Chemical Containers, Inc. - Custom Equipment



Sprayer Parts and Accessories - In Stock



"Specialists In Liquid Handling Products & Equipment"

**413 ABC Rd.
Lake Wales, Fl.
33859
(863) 638-1407**

**15897 Orange Ave.
Ft. Pierce, Fl.
34945
(772) 801-5326**

**440 N. Brevard Ave.
Arcadia, Fl.
34266
(863) 491-0165**

**6402 US Hwy 27 South
Sebring, Fl.
33876
(863) 314-6647**

**601 Hitchcock St.
Suite 103
Plant City, Fl.
33563
(813) 752-1982**

**699 South State St.
Lyons, Ga.
30436
(912) 388-2154**

www.chemicalcontainers.com

Sales 800-346-7867 • Fax 863-638-1863