



WHEEL SAW ATTACHMENT



One Tough Animal™



Specifications

Wheel Saw	WS18	WS24
Overall Width	68.5 in. (1740 mm)	68.5 in. (1740 mm)
Overall Length	69 in. (1753 mm)	74 in. (1880 mm)
Overall Height	64 in. (1626 mm)	81 in. (2057 mm)
Weight (Less Wheel and Trench Cleaner)	1567 lb. (711 kg)	1865 lb. (846 kg)
Hydraulic Side Shift	25.6 in. (650 mm)	25.6 in. (650 mm)
Hydraulic Flow Required	25-40 gpm (95-151 L/min.)	25-40 gpm (95-151 L/min.)
Trenching Depth	6.0-18.0 in. (152-457 mm)	8.0-24.0 in. (203-610 mm)

WS18 Wheel Options	3 in.	6 in.	8 in.
Overall Width	3.13 in. (80 mm)	6.25 in. (159 mm)	7.88 in. (200 mm)
Weight	650 lb. (295 kg)	395 lb. (179 kg)	442 lb. (200 kg)
Tool Bit Quantity	64	56	62
Trench Cleaner Weight	N/A	95 lb. (43 kg)	113 lb. (51 kg)

WS24 Wheel Options	6 in.	8 in.
Overall Width	6.25 in. (159 mm)	7.88 in. (200 mm)
Weight	585 lb. (265 kg)	618 lb. (280 kg)
Tool Bit Quantity	96	96
Trench Cleaner Weight	130 lb. (59 kg)	148 lb. (67 kg)

Cut through a variety of surfaces with the Bobcat wheel saw attachment.

Powered by a high-flow Bobcat loader, wheel saw models WS18 and WS24 cut through asphalt, concrete, frozen ground and wire mesh. These rugged attachments are used for road repair and for laying water, gas, electric and fiber-optic cables.

The trench cleaner, which is raised and lowered hydraulically, assures a clean trench.

Bobcat wheel saws provide a more precise cut than air or hydraulic hammers and are easier to transport than dedicated machines.

NOTE - Where applicable, dimensions are in accordance with Society of Automotive Engineers (SAE) and ISO standards. Specifications and design are subject to change without notice. Pictures of Bobcat units may show other than standard equipment. All dimensions are given for loader equipped with standard tires. All dimensions are shown in inches. Respective metric dimensions are enclosed by parentheses. Bobcat Company complies with the requirements of ISO 9001 as registered with BSI.

The Bobcat Attachments Advantage: Bobcat attachments are engineered and manufactured to fit Bobcat loaders for optimum job performance, dependability and durability.

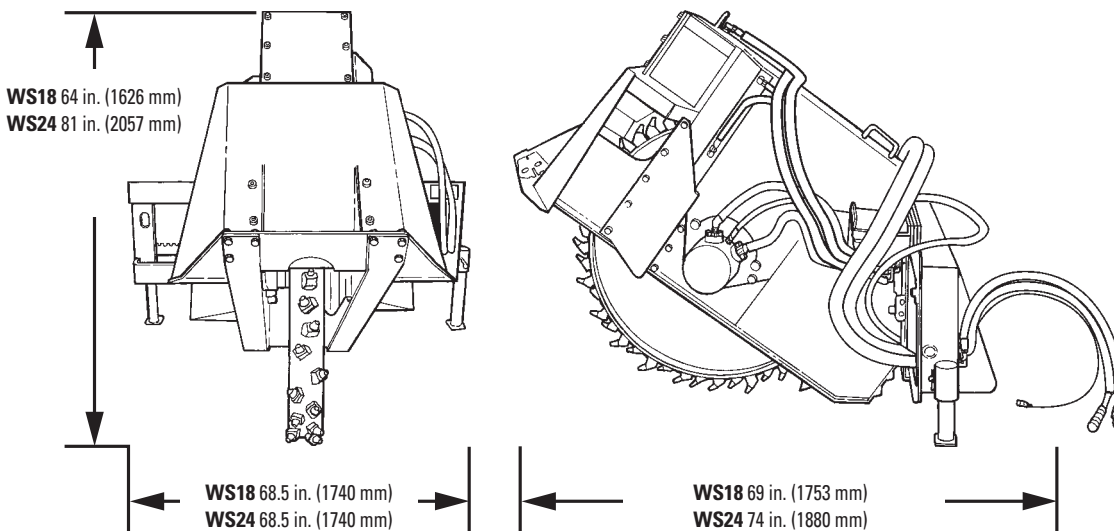

Bobcat Wheel Saw Attachment fits these carrier models:

Skid-Steer Loaders:
S185H
S205H
S220H
S250H
S300H
S330H

Compact Track Loaders:
T180H
T190H
T250H
T300H

All-Wheel Steer Loaders:
A300H