

ICS Sub 24 Powered Subwoofer  
Owner's Manual

# ICS Sub 24



# Snell

## SAFETY INSTRUCTIONS

---



**Warning:** To reduce the risk of fire or electric shock, do

not expose this appliance to rain or moisture.



The lightning flash with arrowhead symbol, within an equilateral triangle, is intended to alert the user to the presence of uninsulated "dangerous voltage" within the product's enclosure that may be of sufficient magnitude to constitute a risk of electric shock to persons.



The exclamation point within an equilateral triangle is intended to alert you to the presence of important operating and maintenance (servicing) instructions in the literature accompanying the appliance.

**Read Instructions:** All the safety and operating instructions should be read before the appliance is operated.

**Retain Instructions:** The safety and operating instructions should be retained for future reference.

**Heed Warnings:** All warnings on the appliance and in the operating instructions should be adhered to.

**Follow Instructions:** All operation and other instructions should be followed.

**Water and Moisture:** The appliance should not be used near water—for example, near a bathtub, washbowl, kitchen sink, laundry tub, in a wet basement, or near a swimming pool, etc.

**Carts and Stands:** The appliance should be used only with a cart or stand that is recommended by the manufacturer.

**Wall or Ceiling Mounting:** The appliance should not be mounted to a wall or ceiling.

**Ventilation:** The appliance should be situated so that its location or position does not interfere with its proper functioning. For example, the appliance should not be situated on a bed, sofa, rug, or similar surface that may obstruct the heat sink surfaces; or placed in a built-in installation, such as a bookcase or cabinet that may impede the flow of air near the heat sink surfaces.

**Heat:** The appliance should be situated away from heat sources, such as radiators, stoves, or other appliances that produce heat.

**Power Sources:** The appliance should be connected to a power supply only of the type described in the operation instructions or as marked on the appliance.

**Power Cord Protection:** Supplies should be routed so that they are not likely to be walked on or pinched by items placed upon or against them. Pay particular attention to cords and plugs, convenience receptacles, and the point where they exit from the appliance.

**Cleaning:** The appliance should only be cleaned as recommended by the manufacturer.

**Non-Use Periods:** The power supply cord should be unplugged from the outlet when left unused for long periods of time.

**Object and Liquid Entry:** Care should be taken so that objects do not fall into and liquids are not spilled into the inside of the appliance.

**Damage Requiring Service:** The appliance should be serviced if any of the following events occur:

- ▶ The power supply or plug has been damaged.
- ▶ Objects have fallen, or liquid has been spilled into the appliance.
- ▶ The appliance has been exposed to rain.
- ▶ The appliance does not appear to operate normally or exhibits a marked change in performance.
- ▶ The appliance has been dropped, or the enclosure is damaged.

**Servicing:** The user should not attempt to service the appliance beyond what is described in the operating instructions. For all other servicing, consult your dealer or contact Snell Acoustics.

## SPECIFICATIONS

---

Frequency Response ( $\pm 3$ dB)	23-200Hz; 20Hz at -6dB
Amplifier Power	450 watts
Crossover Low Pass for Subwoofer	Variable from 50 to 150Hz
Crossover High Pass for Line Out	Fixed at 80Hz, 12dB/octave
Bass Unit	Dual 12-inch (305mm) long throw cast chassis woofers
Cabinet Construction	Double-wall 3/4-inch MDF. Internal Double-H bracing.
Grille	Black cloth covered grille
Controls	Turn On switch with instant On and ten-minute Off delay, Phase Switch and Front mounted volume control
Dimensions (HxWxD, feet installed)	30 <sup>3</sup> / <sub>4</sub> " x 17 <sup>1</sup> / <sub>2</sub> " x 22 <sup>1</sup> / <sub>4</sub> " (78.1cm x 44.45 x 56.51cm) – positioned vertically 19 <sup>1</sup> / <sub>4</sub> " x 29" x 22 <sup>1</sup> / <sub>4</sub> " (78.1cm x 44.45 x 56.51cm) – positioned horizontally (depth includes grille and amplifier fins, feet account for 1 <sup>3</sup> / <sub>4</sub> " / 4.44cm of height)
Weight	116 lbs. (52.62kg)
Finish	Black utility finish, hand-sanded, hand-painted
Accessories	4 cabinet feet

## INTRODUCTION

---

We designed the ICS Sub 24 for maximum output and performance for today's digital formats. With bass extension to 20 Hz (-6dB), and output over 105 dB at an average listening position in a 3,000 cubic foot room, the ICS Sub 24 meets the demanding specifications of THX Ultra 2.

In addition to powerful and sophisticated electronics and drivers, the ICS Sub 24 offers outstanding flexibility. The cabinet has been designed to function in either a horizontal or vertical orientation and front-mounted gain control provides easy access for subwoofer level adjustments.

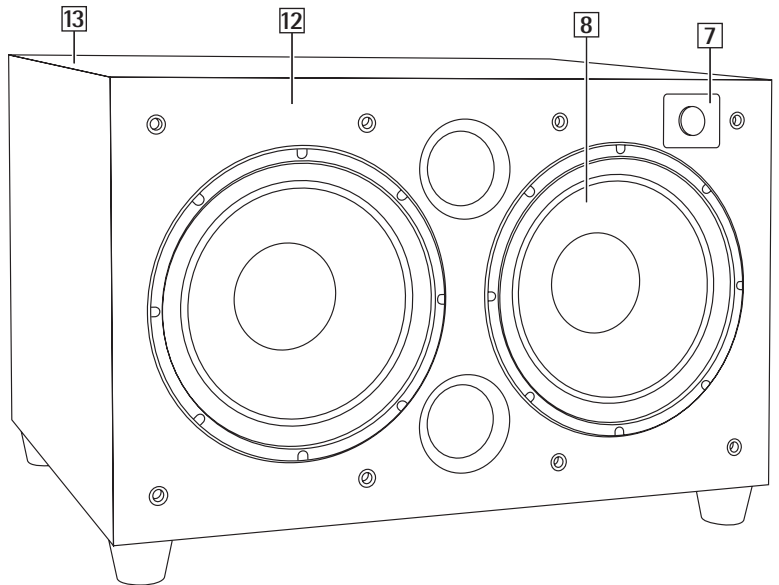
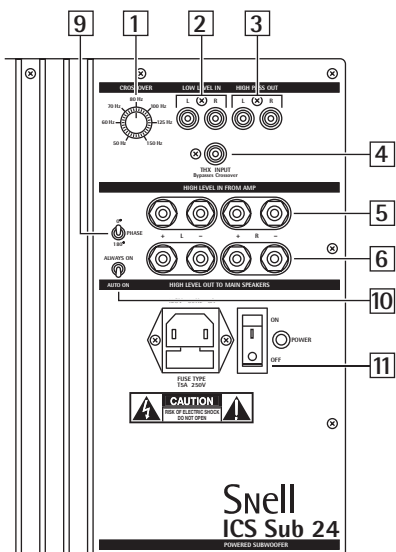
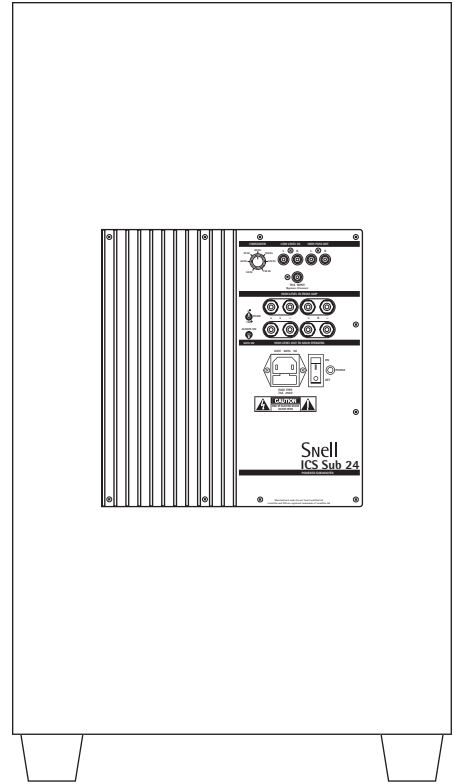
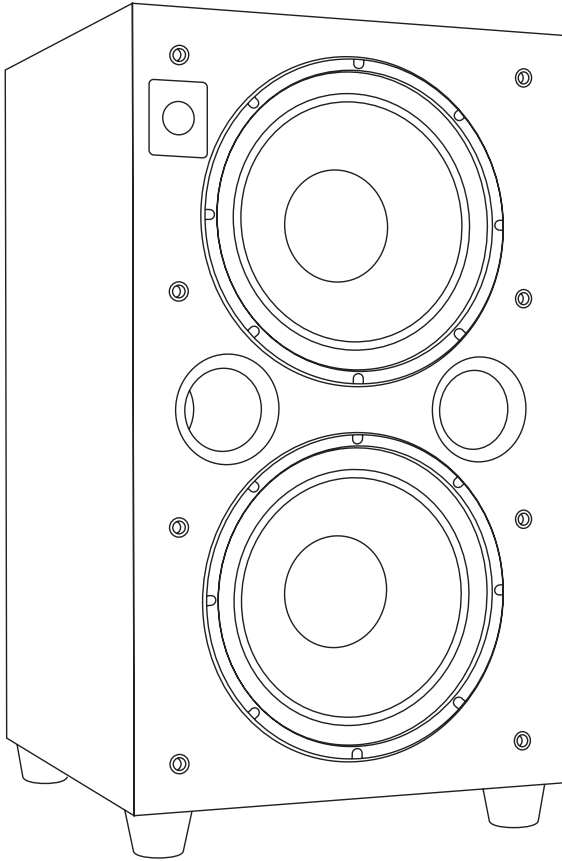

## FEATURES

---

### **1 Crossover Low-Pass Filter Control**

This control sets the frequency of the low-pass filter, and is fully adjustable from 50 to 150Hz. Bass sound below the selected setting are directed to the ICS Sub 24 amplifier and speaker.

### **2 Low Level Inputs**

Use this input when your system has preamp outs and amplifier inputs.

### **3 Low Level High Pass Outputs**

When the low level inputs are used, these outputs provide the signal that goes to the power amplifier in the system. The signal from these outputs is high pass filtered to remove bass sound below 80 Hz.

### **4 THX Input**

This input is for use with receivers or surround sound controllers that have built-in THX control systems. This input bypasses the low pass filter and *ALL* the crossover controls of the ICS Sub 24.

### **5 Speaker Level Inputs**

The ICS Sub 24 also has high-level inputs that can be used when preamp outputs/power amp inputs are not available. The 5-way gold-plated terminals accept spade lugs to 5/16 inch, pins, banana plugs, and up to 12-gauge bare wire. When main speakers are connected to the speaker level

### **6 Speaker Level Outputs**

These outputs provide signals for the main speakers when the speaker level inputs are used. The signal from this output is high pass filtered to remove bass information below 80 Hz.

### **7 Bass Level Control**

The Bass Level control adjusts the sound level output of the ICS Sub 24. It is located on the front of the cabinet, behind the grille.

To access the control grasp the top and bottom edges of the grill and pull it straight off the front of the cabinet. A typical setting for the control is around the 12 o'clock position.

### **8 Bass Drivers**

The ICS Sub 24 uses two 12-inch (305 mm) custom-built bass unit with dual spiders, a coated paper cone with butyl surround, and a die-cast aluminum chassis. The driver has a front-mounted heat sink that draws heat away from the voice coil, increasing power capacity.

### **9 Phase Switch**

Determines whether the subwoofer adds or cancels in the crossover region. The proper setting changes based upon the current location of the speaker.

### **10 Turn On Mode**

This switch controls the automatic power up function. When the switch is set to Auto On, the amplifier will power up when it senses an input signal. If no input signal is present, the amplifier switches to low power standby mode after 8-10 minutes. The LED next to the Power switch lights green when the amplifier is on, and yellow when it is in standby mode. Put the switch in the Always On position to defeat the automatic power down feature.

### **11 Power Switch**

The main power switch is located next to the power cord socket. Push in the top side of the switch to turn on the main power to the system. Push in the bottom side to turn off the main power. Usually the only time the main power switch should be turned off is when the subwoofer will not be used for an extended period of time, such as when you are away on a vacation.

### **12 Handmade Cabinets**

Our cabinet department hand assembles each unit, and then hand sands each several times. The result is a cabinet of exceptional workmanship, with sharp corners and smooth sides.

### **13 Veneers**

We use premium, book-matched veneers, chosen for grain consistency and aesthetics. Our cabinet shop sequences the veneer, maintaining a match from the left side, across the top, to the right side of the speaker. We even veneer the inside of the cabinet so it won't warp or separate at the edges as the humidity changes .

## CONNECTION

**Warning:** To reduce the risk of electric shock, always switch off the subwoofer and the amplifier and or receiver when making connections to the subwoofer and speakers.

### THX® Input

Use this input when the ICS Sub 24 is connected to a receiver or surround sound controller that has a built-in THX control system. This input bypasses **ALL** the crossover and control circuitry of the ICS Sub 24.

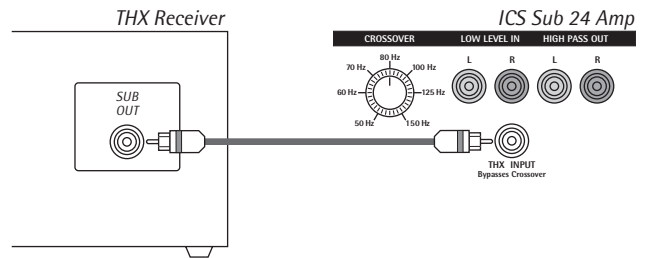

### Non-THX Low Level Connection

When connecting the ICS Sub 24 to electronics that does not have a THX control system, use the low level (also called line level) connections whenever possible. Even if you do not have a separate preamp and power amp, many receivers and integrated amplifiers include "Preamp Out" and "Amplifier In" connectors.

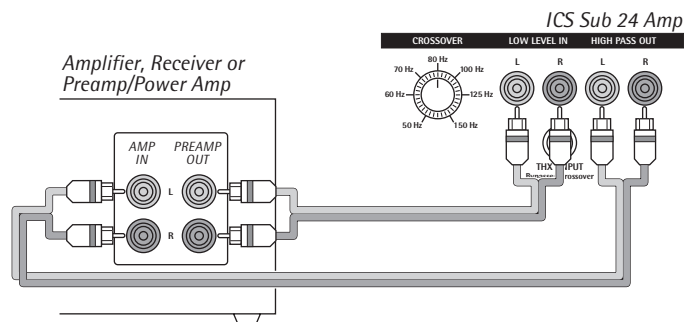

When using the low level connections, the signal from the High Pass Outputs that is returned to your amplifier is high pass filtered to remove sound below 80Hz. This is a non-adjustable filter. It is not affected by the setting of the Crossover control. See the Fine Tuning section of this manual for more information.

### Subwoofer Output Connection

Some electronics have monophonic subwoofer outputs. If your system has this type of an output it can be connected to either of the low level inputs. The benefit of using this type of connection instead of using the THX input is that it does not bypass the controls of the ICS Sub 24. You can still use the level control to adjust the output of the subwoofer. Typically such outputs are low pass filtered, so you should set the ICS Sub 24 crossover control to it's highest setting to minimize its effect. If listening test show there is an excess of mid-bass sound you may want to use a lower crossover control setting. See the "Fine-Tuning Your Subwoofer" section for more information.

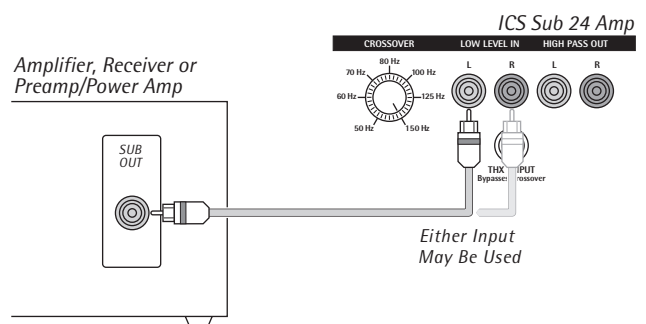

## High Level Connection

If the electronics in your system does not have Preamp Output/Power Amp Input connections, the ICS Sub 24 can be connected via the speaker wiring using the "High Level" Connections. There are two methods for making high level connections the ICS Sub 24.

The 5-way binding posts on the ICS Sub 24 permit easy connection to banana plugs, spade lugs, and bare wire. If you are connecting bare wires be sure to twist the wire strands into a neat bundle. Be sure there are no loose strands that could touch another terminal and cause a short-circuit.

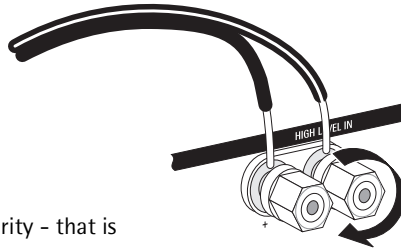

**NOTE:** When making high level connections be sure to maintain proper polarity - that is connect + to + (positive) to (positive) and - to - (negative) to (negative). All wire has one of its conductors marked in some way to make it easy to trace the connections. Typically there is a stripe on the insulation or a rib molded into it. Or the insulation will be transparent and the wire strands of one conductor will be copper colored and the other will be silver colored.

### Preferred Connection Method

The preferred method for making high level connections is to connect the speaker outputs of your amplifier to the High Level inputs of the ICS Sub 24, and then connect the main speakers to the High Level Outputs. This is the best connection method because the High Level Outputs are high pass filtered - the low bass sound is removed. The reduces the portion of the sound range the main speakers must reproduce and makes it easier to adjust the system for a smooth main speaker-to-subwoofer transition.

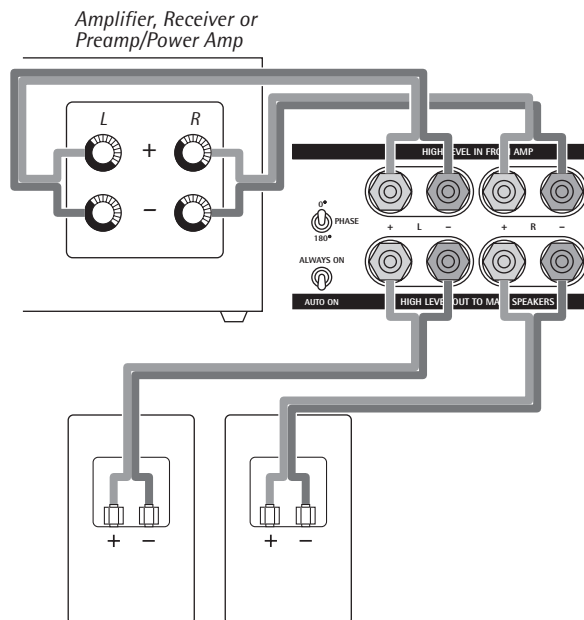

### Alternate High Level Connection

The alternate method for making high level connections is to connect both the ICS Sub 24 and the main speakers directly to the amplifier. This type of connection does not take advantage of the high pass filter provided by the High Level Outputs of the ICS Sub 24. Consequently the main speakers will operate full range.

There are two connection methods. Both methods are electrically equivalent. Which one you use will depend largely on your physical set up of your room.

One method is to connect both the main speakers and the ICS Sub 24 directly to the amplifier.

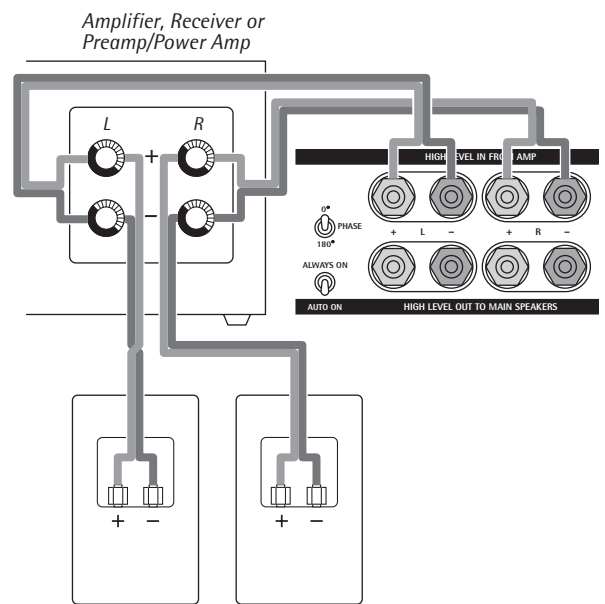

The other method is to connect the amplifier to the main speakers and then run extension wires from the main speakers to the ICS Sub 24.

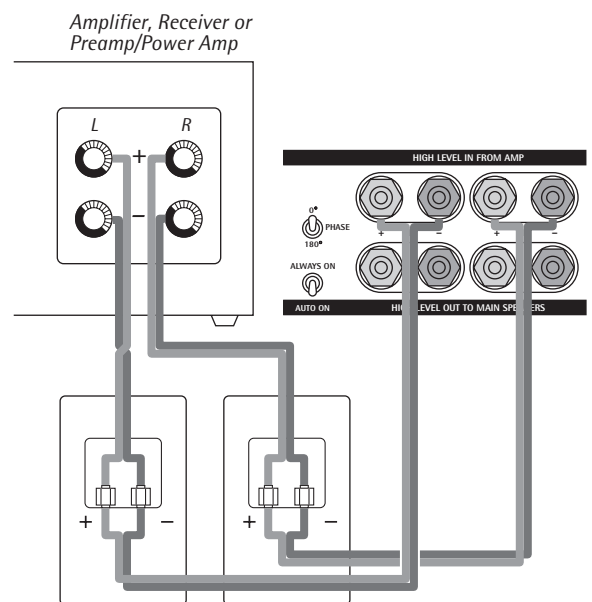



## CONNECTING TWO ICS Sub 24's

You may wish to use two ICS Sub 24's, particularly if you are in a large room.

- ▶ Double subwoofers may be wired with either speaker-level or line-level connections.
- ▶ Be sure the Phase Switch is set the same on both units.

To connect two ICS Sub 24's using line-level inputs, use "Y" connectors to daisy chain the "PREAMP OUT" signal to the input of a second ICS Sub 24.

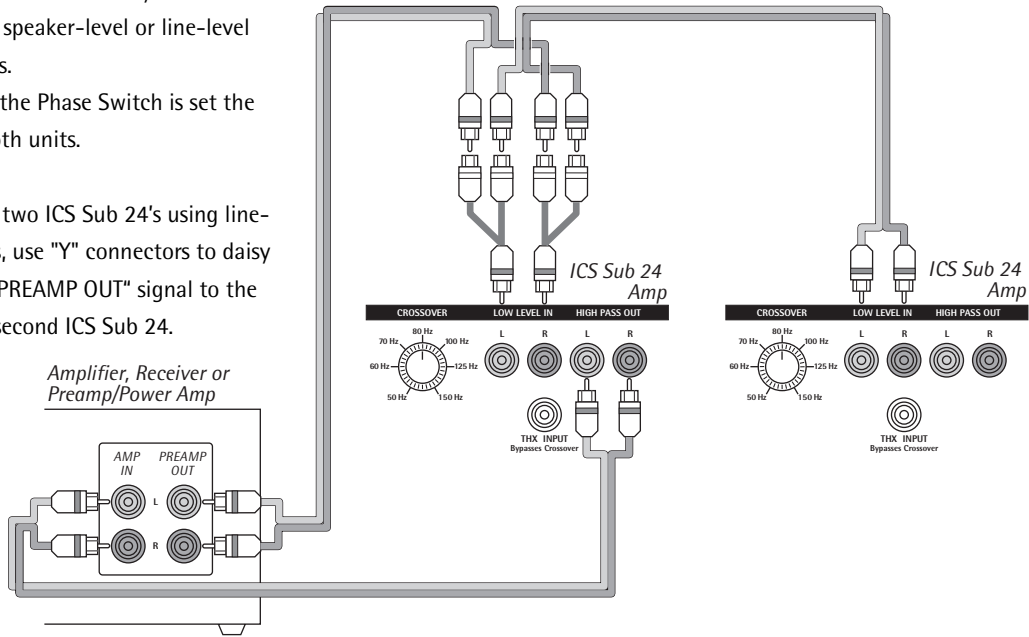

To connect two ICS Sub 24's using speaker-level inputs, use the "HIGH LEVEL IN FROM AMP" binding posts on one subwoofer to daisy chain to the second ICS Sub 24.

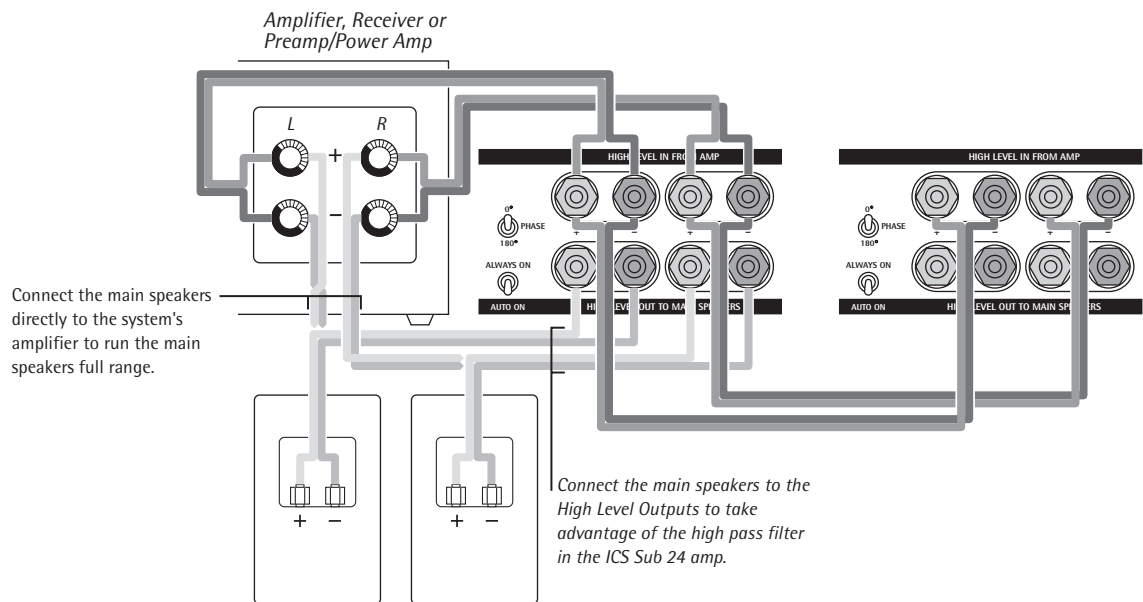

## PLACEMENT

---

Typically the ICS Sub 24 will produce the smoothest response when placed against a wall. Placement in a corner will further enhance bass output allowing you to run operate the subwoofer at a lower power level. Experiment with subwoofer placement while at the same time adjusting crossover frequency, output level, and phase. (See section on Fine-Tuning Your Subwoofer below.)

Choose a musical selection with a heavy and continuous bass line. Play a short section several times until you have a firm impression of it in your mind. Then try another location to see if it provides smoother or more balanced response. Repeat this process until you are content with the bass response you are getting. Strive for a smooth, solid bass response that does not emphasize any part of the bass range.

Once a location for the subwoofer has been selected, you may want to attach the supplied cabinet feet. There are two side of the cabinet that have pre-drilled pilot holes for the feet. This enables you to use either a vertical or horizontal orientation.

**Note:** Avoid placing the ICS Sub 24 close to a television or monitor. There should be at least 8 inches (20cm) between the two components. If getting the best sound, together with the physical constrains of the room, require that the two units must be closer than that you can purchase a magnetic shielding kit from Snell Acoustics.

## FINE-TUNING YOUR SUBWOOFER

---

**Note:** If you are connecting the ICS Sub 24 to a THX receiver/controller, use the THX input. (See the "THX Input" section on page 6.) This bypasses all the crossover circuits and level controls in the amplifier. All audio controlling is done by the THX receiver/controller.

### Setting the Internal Crossover

When using the standard Low Inputs or High Level inputs you will need to adjust the internal crossover to make the ICS Sub 24 sonically blend with the main speaker in the system.

If you are using line-level inputs and returning the high-pass filtered signal to the amplifier (see the diagram on page 6), begin by setting the crossover at 100Hz. Some rooms naturally overemphasize bass in this region, creating an undesirable "bump" or "boomy" quality in the sound. If this is the case with your room, try turning the crossover down to 80Hz. On the other hand, some rooms have a natural tendency to "swallow up" the bass in the 100Hz region, causing the sound to appear thin. In rooms of this type, try setting the crossover at 125Hz. This may help to round out the overall sound.

If you are running your main speakers full range, set the crossover close to the bass cut-off frequency of your main speakers. See the specifications for your main speakers for information. This will help achieve a smooth, seamless blend between your speakers and the subwoofer. Experiment until you are happy with the main speaker-to-subwoofer transition.

## **Bass Level Control**

The Bass Level control adjusts the volume of the ICS Sub 24 output. The Level Control should be adjusted to achieve a good main speaker-to-subwoofer balance. However there is significant interaction between the Crossover control and the Bass Level control. This interaction affects the sound in the midbass range where the transition from the main speakers to the subwoofer occurs. If you are hearing too much midbass, adjust the crossover frequency down while increasing the bass level. This decreases midbass output while increasing the amount of lower bass energy. Conversely, turning down the bass level while slightly increasing the crossover frequency will increase the ratio of mid bass-to-low bass sound. The result will be a sound with a "quick" quality. Experiment while listening to a variety of sources. Adjust the ICS Sub 24 Crossover and Bass Level controls until you achieve a smooth and seamless blend with the main speakers .

## **Setting the Phase**

The proper setting for the Phase Switch changes based upon the location of the speaker. To determine the correct setting for your room, use a source with a full and continuous bass line. Have a second person repeatedly switch the Phase Switch from one position to the other. You will notice that one position will deliver stronger midbass sound. This is the proper position for the Phase Switch. If the midbass now seems too prominent, compensate by slightly lowering the crossover frequency or the output level.

## **How To Care For Your Speakers**

- ▶ Use a soft terry cloth towel slightly dampened with water, glass cleaner, or a diluted mild detergent. The towel should be just damp enough to wipe the surface clean without leaving a trail of moisture.
- ▶ Do not use abrasive cleaners or any cleaner containing chemicals harsher than those found in glass cleaner.

## LIMITED WARRANTY

---

During the warranty period, Snell Acoustics will repair, for the original owner, any defect in materials or workmanship that occurs in normal use of the speaker system, without charge for parts and labor. The warranty period for all parts of the ICS Sub 24, except the amplifier, is five (5) years. The warranty period on the amplifier is one (1) year.

Your responsibilities are to use the product according to the instructions supplied, to provide safe and secure transportation to an authorized Snell Acoustics service representative, and to present proof of purchase from an authorized Snell dealer in the form of your sales slip when requesting service.

Excluded from this warranty is damage that results from abuse, misuse, accidents, shipping, repairs, or modifications by anyone other than an authorized Snell Acoustics service representative. This warranty is void if the serial number has been removed or defaced.

This warranty gives you specific legal rights, and you may also have other rights that vary from state to state.

### If Service Seems Necessary

Contact the dealer from whom you purchased the speaker system. If that is not possible, call us at 978-373-6114, or write to:

Snell Acoustics  
143 Essex Street  
Haverhill, MA 01832

We will promptly advise you of what action to take. If it is necessary to return your speaker system to the factory, please ship it prepaid in the original factory packaging. Please note that Snell Acoustics will not be held liable for shipping damage due to improper packaging. After it has been repaired, we will return it freight-prepaid in the U.S. or Canada.

# Snell

143 Essex Street  
Haverhill, MA 01832  
phone: 978-373-6114  
fax: 978-373-6172  
email: [info@snellacoustics.com](mailto:info@snellacoustics.com)  
web: [www.snellacoustics.com](http://www.snellacoustics.com)